

MC100EL14

5V ECL 1:5 Clock Distribution Chip

The MC100EL14 is a low skew 1:5 clock distribution chip designed explicitly for low skew clock distribution applications. The V_{BB} pin, an internally generated voltage supply, is available to this device only. For single-ended input conditions, the unused differential input is connected to V_{BB} as a switching reference voltage. V_{BB} may also rebias AC coupled inputs. When used, decouple V_{BB} and V_{CC} via a 0.01 μ F capacitor and limit current sourcing or sinking to 0.5 mA. When not used, V_{BB} should be left open.

The EL14 features a multiplexed clock input to allow for the distribution of a lower speed scan or test clock along with the high speed system clock. When LOW (or left open and pulled LOW by the input pulldown resistor) the SEL pin will select the differential clock input.

The common enable (\overline{EN}) is synchronous so that the outputs will only be enabled/disabled when they are already in the LOW state. This avoids any chance of generating a runt clock pulse when the device is enabled/disabled as can happen with an asynchronous control. The internal flip flop is clocked on the falling edge of the input clock, therefore all associated specification limits are referenced to the negative edge of the clock input.

- 50 ps Output-to-Output Skew
- Synchronous Enable/Disable
- Multiplexed Clock Input
- The 100 Series Contains Temperature Compensation
- PECL Mode Operating Range: $V_{CC} = 4.2$ V to 5.7 V with $V_{EE} = 0$ V
- NECL Mode Operating Range: $V_{CC} = 0$ V with $V_{EE} = -4.2$ V to -5.7 V
- Q Output will Default LOW with Inputs Open or at V_{EE}
- Internal Input Pull-down Resistors on All Inputs, Pull-up Resistors on Inverted Inputs
- Pb-Free Package is Available*



ON Semiconductor®

<http://onsemi.com>

MARKING DIAGRAM*

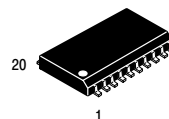

**SOIC-20L
DW SUFFIX
CASE 751D**

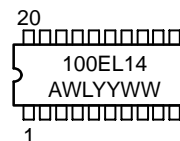

A = Assembly Location
WL = Wafer Lot
YY = Year
WW = Work Week

*For additional marking information, refer to Application Note AND8002/D.

ORDERING INFORMATION

See detailed ordering and shipping information in the package dimensions section on page 6 of this data sheet.

*For additional information on our Pb-Free strategy and soldering details, please download the ON Semiconductor Soldering and Mounting Techniques Reference Manual, SOLDERRM/D.

MC100EL14

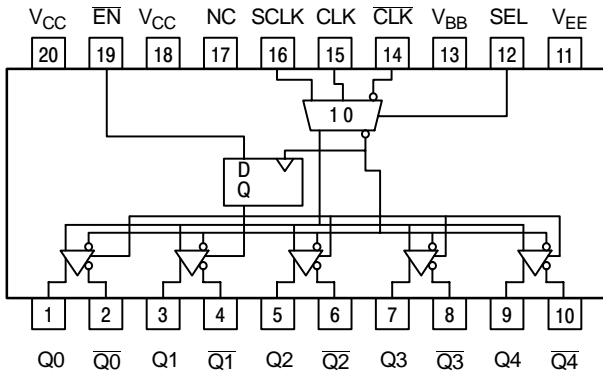

* All V_{CC} pins are tied together on the die.

Warning: All V_{CC} and V_{EE} pins must be externally connected to Power Supply to guarantee proper operation.

Figure 1. Logic Diagram and Pinout Assignment

Table 1. PIN DESCRIPTION

PIN	FUNCTION
CLK, $\overline{\text{CLK}}$	ECL Diff Clock Inputs
SCLK	ECL Scan Clock Input
EN	ECL Sync Enable
SEL	ECL Clock Select Input
Q ₀₋₄ , $\overline{\text{Q}}_{0-4}$	ECL Diff Clock Outputs
V _{BB}	Reference Voltage Output
V _{CC}	Positive Supply
V _{EE}	Negative Supply
NC	No Connect

Table 2. FUNCTION TABLE

CLK*	SCLK*	SEL*	EN*	Q
L	X	L	L	L
H	X	L	L	H
X	L	H	L	L
X	H	H	L	H
X	X	X	H	L

(Note)

1. On next negative transition of CLK or SCLK

**Pins will default low when left open.

Table 3. ATTRIBUTES

Characteristics	Value
Internal Input Pulldown Resistor	75 k Ω
Internal Input Pullup Resistor	75 k Ω
ESD Protection	Human Body Model > 2 kV Machine Model > 200 V Charge Device Model > 4 kV
Moisture Sensitivity (Note 2)	Level 1
Flammability Rating	Oxygen Index: 28 to 34 UL 94 V-0 @ 0.125 in
Transistor Count	303 Devices
Meets or Exceeds JEDEC Spec EIA/JESD78 IC Latchup Test	

2. For additional Moisture Sensitivity information, refer to Application Note AND8003/D.

MC100EL14

Table 4. MAXIMUM RATINGS

Symbol	Parameter	Condition 1	Condition 2	Rating	Unit
V_{CC}	PECL Mode Power Supply	$V_{EE} = 0\text{ V}$		8	V
V_{EE}	NECL Mode Power Supply	$V_{CC} = 0\text{ V}$		-8	V
V_I	PECL Mode Input Voltage	$V_{EE} = 0\text{ V}$	$V_I \leq V_{CC}$	6	V
	NECL Mode Input Voltage	$V_{CC} = 0\text{ V}$	$V_I \geq V_{EE}$	-6	V
I_{out}	Output Current	Continuous Surge		50	mA
				100	mA
I_{BB}	V_{BB} Sink/Source			± 0.5	mA
T_A	Operating Temperature Range			-40 to +85	$^{\circ}\text{C}$
T_{stg}	Storage Temperature Range			-65 to +150	$^{\circ}\text{C}$
θ_{JA}	Thermal Resistance (Junction-to-Ambient)	0 lfpm	SOIC-20L	90	$^{\circ}\text{C}/\text{W}$
		500 lfpm	SOIC-20L	60	$^{\circ}\text{C}/\text{W}$
θ_{JC}	Thermal Resistance (Junction-to-Case)	Standard Board	SOIC-20L	30 to 35	$^{\circ}\text{C}/\text{W}$
T_{sol}	Wave Solder	< 2 to 3 sec @ 248 $^{\circ}\text{C}$		265	$^{\circ}\text{C}$

Maximum ratings are those values beyond which device damage can occur. Maximum ratings applied to the device are individual stress limit values (not normal operating conditions) and are not valid simultaneously. If these limits are exceeded, device functional operation is not implied, damage may occur and reliability may be affected.

MC100EL14

Table 5. 100EL SERIES PECL DC CHARACTERISTICS $V_{CC} = 5.0\text{ V}$; $V_{EE} = 0.0\text{ V}$ (Note 3)

Symbol	Characteristic	-40°C			25°C			85°C			Unit
		Min	Typ	Max	Min	Typ	Max	Min	Typ	Max	
I_{EE}	Power Supply Current		32	40		32	40		34	42	mA
V_{OH}	Output HIGH Voltage (Note 4)	3915	3995	4120	3975	4045	4120	3975	4050	4120	mV
V_{OL}	Output LOW Voltage (Note 4)	3170	3305	3445	3190	3295	3380	3190	3295	3380	mV
V_{IH}	Input HIGH Voltage (Single-Ended)	3835		4120	3835		4120	3835		4120	mV
V_{IL}	Input LOW Voltage (Single-Ended)	3190		3525	3190		3525	3190		3525	mV
V_{BB}	Output Voltage Reference	3.62		3.74	3.62		3.74	3.62		3.74	V
V_{IHCMR}	Common Mode Range (Differential Configuration) (Note 5) $V_{PP} < 500\text{ mV}$ $V_{PP} \geq 500\text{ mV}$										V
		1.3		4.6	1.2		4.6	1.2		4.6	
		1.5		4.6	1.4		4.6	1.4		4.6	
I_{IH}	Input HIGH Current			150			150			150	μA
I_{IL}	Input LOW Current	0.5			0.5			0.5			μA

NOTE: Device will meet the specifications after thermal equilibrium has been established when mounted in a test socket or printed circuit board with maintained transverse airflow greater than 500 lpm. Electrical parameters are guaranteed only over the declared operating temperature range. Functional operation of the device exceeding these conditions is not implied. Device specification limit values are applied individually under normal operating conditions and not valid simultaneously.

3. Input and output parameters vary 1:1 with V_{CC} . V_{EE} can vary +0.8 V / -0.5 V.

4. Outputs are terminated through a 50 Ω resistor to $V_{CC} - 2.0\text{ V}$.

5. V_{IHCMR} min varies 1:1 with V_{EE} ; V_{IHCMR} max varies 1:1 with V_{CC} . The V_{IHCMR} range is referenced to the most positive side of the differential input signal. Normal operation is obtained if the HIGH level falls within the specified range and the peak-to-peak voltage lies between $V_{PP}(\text{min})$ and 1 V.

Table 6. 100EL SERIES NECL DC CHARACTERISTICS $V_{CC} = 0.0\text{ V}$; $V_{EE} = -5.0\text{ V}$ (Note 6)

Symbol	Characteristic	-40°C			25°C			85°C			Unit
		Min	Typ	Max	Min	Typ	Max	Min	Typ	Max	
I_{EE}	Power Supply Current		32	40		32	40		34	42	mA
V_{OH}	Output HIGH Voltage (Note 7)	-1085	-1005	-880	-1025	-955	-880	-1025	-955	-880	mV
V_{OL}	Output LOW Voltage (Note 7)	-1830	-1695	-1555	-1810	-1705	-1620	-1810	-1705	-1620	mV
V_{IH}	Input HIGH Voltage (Single-Ended)	-1165		-880	-1165		-880	-1165		-880	mV
V_{IL}	Input LOW Voltage (Single-Ended)	-1810		-1475	-1810		-1475	-1810		-1475	mV
V_{BB}	Output Voltage Reference	-1.38		-1.26	-1.38		-1.26	-1.38		-1.26	V
V_{IHCMR}	Common Mode Range (Differential Configuration) (Note 8) $V_{PP} < 500\text{ mV}$ $V_{PP} \geq 500\text{ mV}$										V
		-3.7		-0.4	-3.8		-0.4	-3.8		-0.4	
		-3.5		-0.4	-3.6		-0.4	-3.6		-0.4	
I_{IH}	Input HIGH Current			150			150			150	μA
I_{IL}	Input LOW Current	0.5			0.5			0.5			μA

NOTE: Device will meet the specifications after thermal equilibrium has been established when mounted in a test socket or printed circuit board with maintained transverse airflow greater than 500 lpm. Electrical parameters are guaranteed only over the declared operating temperature range. Functional operation of the device exceeding these conditions is not implied. Device specification limit values are applied individually under normal operating conditions and not valid simultaneously.

6. Input and output parameters vary 1:1 with V_{CC} . V_{EE} can vary +0.8 V / -0.5 V.

7. Outputs are terminated through a 50 Ω resistor to $V_{CC} - 2.0\text{ V}$.

8. V_{IHCMR} min varies 1:1 with V_{EE} ; V_{IHCMR} max varies 1:1 with V_{CC} . The V_{IHCMR} range is referenced to the most positive side of the differential input signal. Normal operation is obtained if the HIGH level falls within the specified range and the peak-to-peak voltage lies between $V_{PP}(\text{min})$ and 1 V.

MC100EL14

Table 7. AC CHARACTERISTICS $V_{CC} = 5.0\text{ V}$; $V_{EE} = 0.0\text{ V}$ or $V_{CC} = 0.0\text{ V}$; $V_{EE} = -5.0\text{ V}$ (Note 9)

Symbol	Characteristic	-40°C			25°C			85°C			Unit
		Min	Typ	Max	Min	Typ	Max	Min	Typ	Max	
f_{max}	Maximum Toggle Frequency (See Figure 2, f_{MAX}/Jitter)		1			1			1		GHz
t_{PLH} t_{PHL}	Prop Delay CLK to Q (Diff) CLK to Q (SE) SCLK to Q	520 470 470		720 770 770	580 530 530	680 680 680	780 830 830	630 580 580		830 880 880	ps
t_{SKEW}	Part-to-Part Skew Within-Device Skew (Note 10)			200 50			200 50			200 50	ps
t_{JITTER}	Random Clock Jitter (RMS) @ 1 GHz (See Figure 2, f_{MAX}/Jitter)		1			1			1		ps
t_S	Setup Time \overline{EN}	0			0	-133		0			ps
t_H	Hold Time \overline{EN}	250			250	140		250			ps
V_{PP}	Input Swing (Note 11)	150		1000	150		1000	150		1000	mV
t_r t_f	Output Rise/Fall Times Q (20% – 80%)	230		500	230		500	230		500	ps

NOTE: Device will meet the specifications after thermal equilibrium has been established when mounted in a test socket or printed circuit board with maintained transverse airflow greater than 500 lfm. Electrical parameters are guaranteed only over the declared operating temperature range. Functional operation of the device exceeding these conditions is not implied. Device specification limit values are applied individually under normal operating conditions and not valid simultaneously.

9. V_{EE} can vary +0.8 V / -0.5 V. Outputs are terminated through a 50 Ω resistor to $V_{CC} - 2.0\text{ V}$.

10. Skews are specified for identical LOW-to-HIGH or HIGH-to-LOW transitions.

11. $V_{PP}(\text{min})$ is the minimum input swing for which AC parameters guaranteed. The device has a DC gain of ≈ 40 .

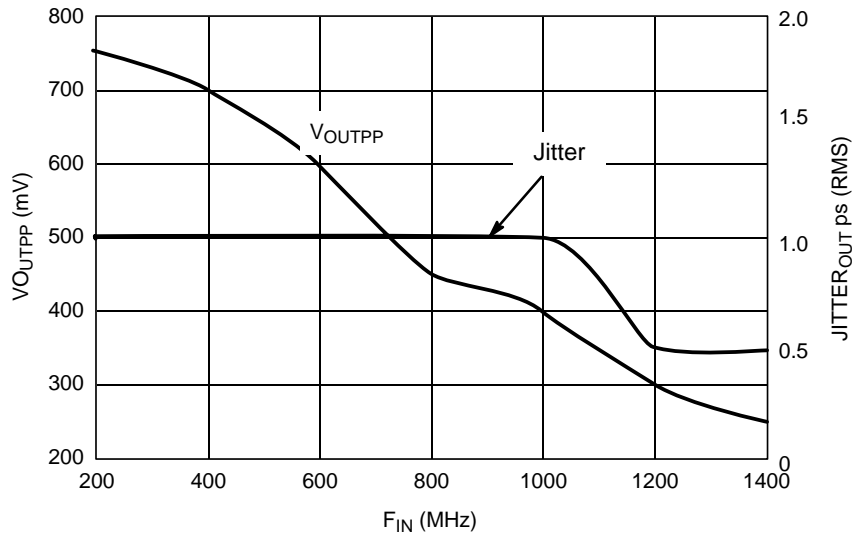
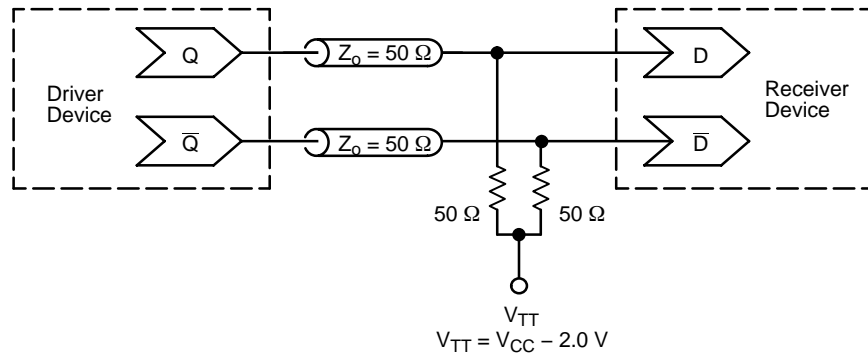

Figure 2. Output Voltage Amplitude / RMS Jitter vs. Input Frequency at Ambient Temperature (Typical)

MC100EL14



**Figure 3. Typical Termination for Output Driver and Device Evaluation
(See Application Note AND8020/D – Termination of ECL Logic Devices.)**

ORDERING INFORMATION

Device	Package	Shipping†
MC100EL14DW	SOIC-20L	38 Units / Rail
MC100EL14DWG	SOIC-20L (Pb-Free)	38 Units / Rail
MC100EL14DWR2	SOIC-20L	1000 / Tape & Reel

†For information on tape and reel specifications, including part orientation and tape sizes, please refer to our Tape and Reel Packaging Specifications Brochure, BRD8011/D.

MC100EL14

Resource Reference of Application Notes

- AN1405/D** – ECL Clock Distribution Techniques
- AN1406/D** – Designing with PECL (ECL at +5.0 V)
- AN1503/D** – ECLinPS™ I/O SPiCE Modeling Kit
- AN1504/D** – Metastability and the ECLinPS Family
- AN1568/D** – Interfacing Between LVDS and ECL
- AN1642/D** – The ECL Translator Guide
- AND8001/D** – Odd Number Counters Design
- AND8002/D** – Marking and Date Codes
- AND8020/D** – Termination of ECL Logic Devices
- AND8066/D** – Interfacing with ECLinPS
- AND8090/D** – AC Characteristics of ECL Devices

MC100EL14

PACKAGE DIMENSIONS

SOIC-20L
DW SUFFIX
PLASTIC SOIC PACKAGE
CASE 751D-05
ISSUE F

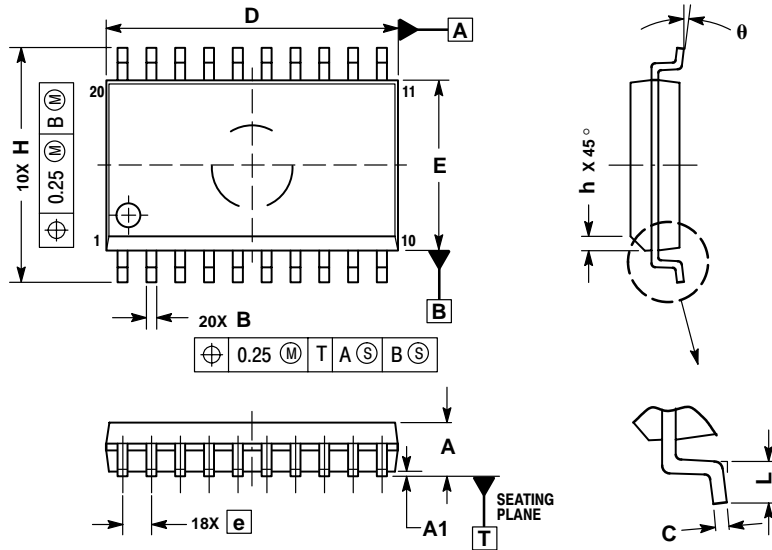

NOTES:

1. DIMENSIONS ARE IN MILLIMETERS.
2. INTERPRET DIMENSIONS AND TOLERANCES PER ASME Y14.5M, 1994.
3. DIMENSIONS D AND E DO NOT INCLUDE MOLD PROTRUSION.
4. MAXIMUM MOLD PROTRUSION 0.15 PER SIDE.
5. DIMENSION B DOES NOT INCLUDE DAMBAR PROTRUSION. ALLOWABLE PROTRUSION SHALL BE 0.13 TOTAL IN EXCESS OF B DIMENSION AT MAXIMUM MATERIAL CONDITION.

DIM	MILLIMETERS	
	MIN	MAX
A	2.35	2.65
A1	0.10	0.25
B	0.35	0.49
C	0.23	0.32
D	12.65	12.95
E	7.40	7.60
e	1.27 BSC	
H	10.05	10.55
h	0.25	0.75
L	0.50	0.90
θ	0°	7°

ECLinPS is a trademark of Semiconductor Components Industries, LLC (SCILLC).

ON Semiconductor and  are registered trademarks of Semiconductor Components Industries, LLC (SCILLC). SCILLC reserves the right to make changes without further notice to any products herein. SCILLC makes no warranty, representation or guarantee regarding the suitability of its products for any particular purpose, nor does SCILLC assume any liability arising out of the application or use of any product or circuit, and specifically disclaims any and all liability, including without limitation special, consequential or incidental damages. "Typical" parameters which may be provided in SCILLC data sheets and/or specifications can and do vary in different applications and actual performance may vary over time. All operating parameters, including "Typicals" must be validated for each customer application by customer's technical experts. SCILLC does not convey any license under its patent rights nor the rights of others. SCILLC products are not designed, intended, or authorized for use as components in systems intended for surgical implant into the body, or other applications intended to support or sustain life, or for any other application in which the failure of the SCILLC product could create a situation where personal injury or death may occur. Should Buyer purchase or use SCILLC products for any such unintended or unauthorized application, Buyer shall indemnify and hold SCILLC and its officers, employees, subsidiaries, affiliates, and distributors harmless against all claims, costs, damages, and expenses, and reasonable attorney fees arising out of, directly or indirectly, any claim of personal injury or death associated with such unintended or unauthorized use, even if such claim alleges that SCILLC was negligent regarding the design or manufacture of the part. SCILLC is an Equal Opportunity/Affirmative Action Employer. This literature is subject to all applicable copyright laws and is not for resale in any manner.

PUBLICATION ORDERING INFORMATION

LITERATURE FULFILLMENT:

Literature Distribution Center for ON Semiconductor
P.O. Box 5163, Denver, Colorado 80217 USA

Phone: 303-675-2175 or 800-344-3860 Toll Free USA/Canada

Fax: 303-675-2176 or 800-344-3867 Toll Free USA/Canada

Email: orderlit@onsemi.com

N. American Technical Support: 800-282-9855 Toll Free
USA/Canada

Japan: ON Semiconductor, Japan Customer Focus Center

2-9-1 Kamimeguro, Meguro-ku, Tokyo, Japan 153-0051

Phone: 81-3-5773-3850

ON Semiconductor Website: <http://onsemi.com>

Order Literature: <http://www.onsemi.com/litorder>

For additional information, please contact your
local Sales Representative.