

# MC100EL91

## 5 V Triple PECL Input to -5 V ECL Output Translator

The MC100EL91 is a triple PECL input to ECL output translator. The device receives standard voltage differential PECL signals, determined by the  $V_{CC}$  supply level, and translates them to differential -5 V ECL output signals. (For translation of LVPECL to -3.3 V ECL output, see MC100LVEL91.)

To accomplish the level translation, the EL91 requires three power rails. The  $V_{CC}$  supply should be connected to the positive supply, and the  $V_{EE}$  pin should be connected to the negative power supply. The GND pins are connected to the system ground plane. Both  $V_{EE}$  and  $V_{CC}$  should be bypassed to ground via 0.01  $\mu$ F capacitors.

Under open input conditions, the  $\bar{D}$  input will be biased at  $V_{CC}/2$  and the D input will be pulled to GND. This condition will force the Q output to a low, ensuring stability.

The  $V_{BB}$  pin, an internally generated voltage supply, is available to this device only. For single-ended input conditions, the unused differential input is connected to  $V_{BB}$  as a switching reference voltage.  $V_{BB}$  may also rebias AC coupled inputs. When used, decouple  $V_{BB}$  and  $V_{CC}$  via a 0.01  $\mu$ F capacitor and limit current sourcing or sinking to 0.5 mA. When not used,  $V_{BB}$  should be left open.

- 670 ps Typical Propagation Delay
- ESD Protection: >2 kV Human Body Model
- The 100 Series Contains Temperature Compensation
- Operating Range:  $V_{CC} = 4.75$  V to 5.5 V;  
 $V_{EE} = -4.2$  V to -5.5 V; GND = 0 V
- Internal Input Pulldown Resistors
- Q Output will Default LOW with Inputs Open or at GND
- Meets or Exceeds JEDEC Spec EIA/JESD78 IC Latchup Test
- Moisture Sensitivity Level 1

For Additional Information, see Application Note AND8003/D

- Flammability Rating: UL 94 V-0 @ 0.125 in, Oxygen Index: 28 to 34
- Transistor Count = 282 devices
- Pb-Free Package is Available\*



**ON Semiconductor**

<http://onsemi.com>

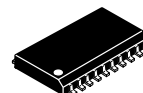

SO-20 WB  
DW SUFFIX  
CASE 751D

### MARKING DIAGRAM\*

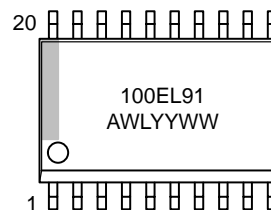

A = Assembly Location  
WL = Wafer Lot  
YY = Year  
WW = Work Week

\*For additional marking information, refer to Application Note AND8002/D.

### ORDERING INFORMATION

See detailed ordering and shipping information in the package dimensions section on page 5 of this data sheet.

\*For additional information on our Pb-Free strategy and soldering details, please download the ON Semiconductor Soldering and Mounting Techniques Reference Manual, SOLDERRM/D.

# MC100EL91

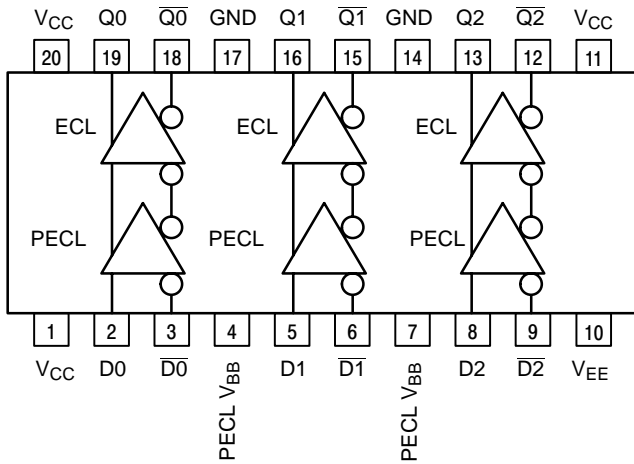

**Table 1. PIN DESCRIPTION**

PIN	FUNCTION
Dn, $\overline{Dn}$	PECL Inputs
Qn, $\overline{Qn}$	ECL Outputs
PECL $V_{BB}$	PECL Reference Voltage Output
$V_{CC}$	Positive Supply
$V_{EE}$	Negative Supply
GND	Ground

\*\*All  $V_{CC}$  pins are tied together on the die.

Warning: All  $V_{CC}$ ,  $V_{EE}$ , and GND pins must be externally connected to Power Supply to guarantee proper operation.

**Figure 1. 20-Lead Pinout (Top View) and Logic Diagram**

**Table 2. MAXIMUM RATINGS**

Symbol	Parameter	Condition 1	Condition 2	Rating	Unit
$V_{CC}$	PECL Power Supply	GND = 0 V		8 to 0	V
$V_{EE}$	NECL Power Supply	GND = 0 V		-8 to 0	V
$V_I$	PECL Input Voltage	GND = 0 V	$V_I \leq V_{CC}$	6 to 0	V
$I_{out}$	Output Current	Continuous Surge		50 100	mA mA
$I_{BB}$	PECL $V_{BB}$ Sink/Source			$\pm 0.5$	mA
$T_A$	Operating Temperature Range			-40 to +85	$^{\circ}C$
$T_{stg}$	Storage Temperature Range			-65 to +150	$^{\circ}C$
$\theta_{JA}$	Thermal Resistance (Junction-to-Ambient)	0 lfpm 500 lfpm	SOIC-20 WB SOIC-20 WB	90 60	$^{\circ}C/W$ $^{\circ}C/W$
$\theta_{JC}$	Thermal Resistance (Junction-to-Case)	Standard Board	SOIC-20 WB	30 to 35	$^{\circ}C/W$
$T_{sol}$	Wave Solder	<2 to 3 sec @ 248 $^{\circ}C$		265	$^{\circ}C$

Maximum ratings are those values beyond which device damage can occur. Maximum ratings applied to the device are individual stress limit values (not normal operating conditions) and are not valid simultaneously. If these limits are exceeded, device functional operation is not implied, damage may occur and reliability may be affected.

# MC100EL91

**Table 3. PECL INPUT DC CHARACTERISTICS**  $V_{CC}= 5.0\text{ V}$ ;  $V_{EE}= -5.0\text{ V}$ ;  $GND= 0\text{ V}$  (Note 1)

Symbol	Characteristic	-40°C			25°C			85°C			Unit
		Min	Typ	Max	Min	Typ	Max	Min	Typ	Max	
$I_{CC}$	$V_{CC}$ Power Supply Current			11		6	11			11	mA
$V_{IH}$	Input HIGH Voltage (Single-Ended)	3835		4120	3835		4120	3835		4120	mV
$V_{IL}$	Input LOW Voltage (Single-Ended)	3190		3525	3190		3525	3190		3525	mV
PECL $V_{BB}$	Output Voltage Reference	3.62		3.74	3.62		3.74	3.62		3.74	V
$V_{IHCMR}$	Input HIGH Voltage Common Mode Range (Differential) (Note 2) $V_{PP} < 500\text{ mV}$ $V_{PP} \geq 500\text{ mV}$	1.3 1.5		4.8 4.8	1.2 1.4		4.8 4.8	1.2 1.4		4.8 4.8	V
$I_{IH}$	Input HIGH Current			150			150			150	$\mu\text{A}$
$I_{IL}$	Input LOW Current	0.5			0.5			0.5			$\mu\text{A}$

NOTE: Device will meet the specifications after thermal equilibrium has been established when mounted in a test socket or printed circuit board with maintained transverse airflow greater than 500 lfm. Electrical parameters are guaranteed only over the declared operating temperature range. Functional operation of the device exceeding these conditions is not implied. Device specification limit values are applied individually under normal operating conditions and not valid simultaneously.

1. Input parameters vary 1:1 with  $V_{CC}$ .  $V_{CC} = +4.75\text{ V}$  to  $+5.2\text{ V}$ ,  $V_{EE} = -4.20\text{ V}$  to  $-5.5\text{ V}$ .
2.  $V_{IHCMR}$  min varies 1:1 with GND.  $V_{IHCMR}$  max varies 1:1 with  $V_{CC}$ .

**Table 4. NECL OUTPUT DC CHARACTERISTICS**  $V_{CC}= 5.0\text{ V}$  to  $5.0\text{ V}$ ;  $V_{EE}= -5.0\text{ V}$ ;  $GND= 0\text{ V}$  (Note 3)

Symbol	Characteristic	-40°C			25°C			85°C			Unit
		Min	Typ	Max	Min	Typ	Max	Min	Typ	Max	
$I_{EE}$	$V_{EE}$ Power Supply Current			28		22	28			30	mA
$V_{OH}$	Output HIGH Voltage (Note 4)	-1085	-1005	-880	-1025	-955	-880	-1025	-955	-880	mV
$V_{OL}$	Output LOW Voltage (Note 4)	-1830	-1695	-1555	-1810	-1705	-1620	-1810	-1705	-1620	mV

NOTE: Device will meet the specifications after thermal equilibrium has been established when mounted in a test socket or printed circuit board with maintained transverse airflow greater than 500 lfm. Electrical parameters are guaranteed only over the declared operating temperature range. Functional operation of the device exceeding these conditions is not implied. Device specification limit values are applied individually under normal operating conditions and not valid simultaneously.

3. Output parameters vary 1:1 with GND.  $V_{CC} = +4.75\text{ V}$  to  $+5.2\text{ V}$ ,  $V_{EE} = -4.20\text{ V}$  to  $-5.5\text{ V}$ .
4. Outputs are terminated through a  $50\ \Omega$  resistor to GND - 2.0 V

# MC100EL91

**Table 5. AC CHARACTERISTICS**  $V_{CC}= 5.0\text{ V}$ ;  $V_{EE}= -5.0\text{ V}$ ;  $GND= 0\text{ V}$  (Note 8).

Symbol	Characteristic	-40°C			25°C			85°C			Unit
		Min	Typ	Max	Min	Typ	Max	Min	Typ	Max	
$f_{max}$	Maximum Toggle Frequency		700			700			700		MHz
$t_{PLH}$ $t_{PHL}$	Propagation Delay D to Q Differential Single-Ended.	540 490	640 640	740 790	570 520	670 670	770 820	610 560	710 710	810 860	ps
$t_{SKEW}$	Skew Output-to-Output (Note 5) Part-to-Part (Differential) (Note 5) Duty Cycle (Differential) (Note 6)		40 25	100 200		40 25	100 200		40 25	100 200	ps
$t_{JITTER}$	Random Clock Jitter @ 700 MHz		1.2			1.2			1.2		pS(RMS)
$V_{PP}$	Input Swing (Note 7)	200		1000	200		1000	200		1000	mV
$t_r$ $t_f$	Output Rise/Fall Times Q (20% – 80%)	270	400	530	270	400	530	270	400	530	ps

NOTE: Device will meet the specifications after thermal equilibrium has been established when mounted in a test socket or printed circuit board with maintained transverse airflow greater than 500 lfm. Electrical parameters are guaranteed only over the declared operating temperature range. Functional operation of the device exceeding these conditions is not implied. Device specification limit values are applied individually under normal operating conditions and not valid simultaneously.

5. Skews are valid across specified voltage range, part-to-part skew is for a given temperature.
6. Duty cycle skew is the difference between a  $t_{PLH}$  and  $t_{PHL}$  propagation delay through a device.
7.  $V_{PP}(\text{min})$  is the minimum input swing for which AC parameters are guaranteed. The device has a DC gain of  $\approx 40$ .
8.  $V_{CC} = +4.75\text{ V}$  to  $+5.2\text{ V}$ ,  $V_{EE} = -4.20\text{ V}$  to  $-5.5\text{ V}$ . Outputs are terminated through a  $50\ \Omega$  resistor to GND – 2.0 V.

## MC100EL91

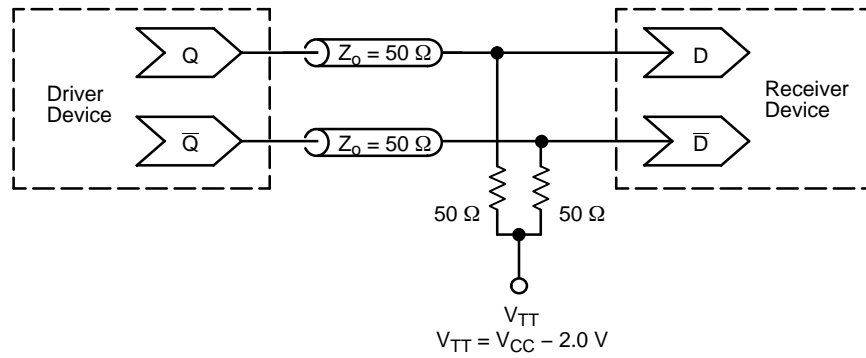

**Figure 2. Typical Termination for Output Driver and Device Evaluation  
(See Application Note AND8020/D – Termination of ECL Logic Devices.)**

### ORDERING INFORMATION

Device	Package	Shipping†
MC100EL91DW	SO-20 WB	38 Units / Rail
MC100EL91DWR2	SO-20 WB	1000 / Tape & Reel
MC100EL91DWR2G	SO-20 WB (Pb-Free)	1000 / Tape & Reel

†For information on tape and reel specifications, including part orientation and tape sizes, please refer to our Tape and Reel Packaging Specifications Brochure, BRD8011/D.

### Resource Reference of Application Notes

- AN1405/D** – ECL Clock Distribution Techniques
- AN1406/D** – Designing with PECL (ECL at +5.0 V)
- AN1503/D** – ECLinPS™ I/O SPICE Modeling Kit
- AN1504/D** – Metastability and the ECLinPS Family
- AN1568/D** – Interfacing Between LVDS and ECL
- AN1642/D** – The ECL Translator Guide
- AND8001/D** – Odd Number Counters Design
- AND8002/D** – Marking and Date Codes
- AND8020/D** – Termination of ECL Logic Devices
- AND8066/D** – Interfacing with ECLinPS
- AND8090/D** – AC Characteristics of ECL Devices

# MC100EL91

## PACKAGE DIMENSIONS

SO-20 WB  
DW SUFFIX  
CASE 751D-05  
ISSUE G

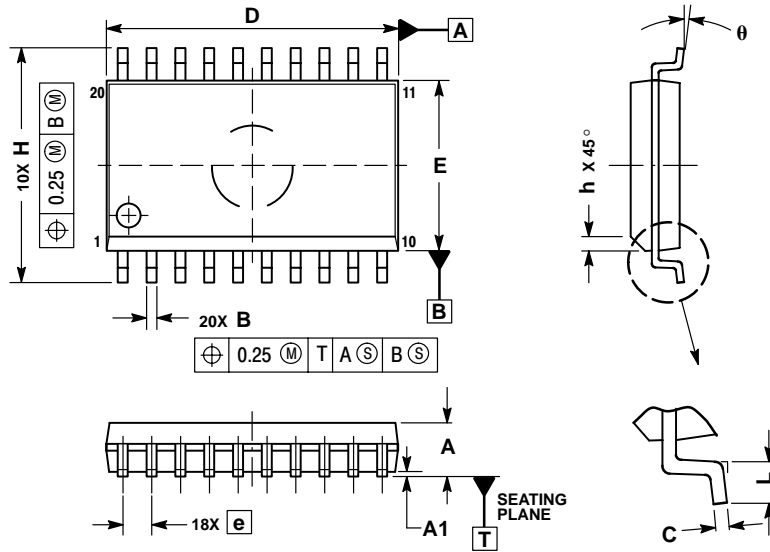

**NOTES:**

1. DIMENSIONS ARE IN MILLIMETERS.
2. INTERPRET DIMENSIONS AND TOLERANCES PER ASME Y14.5M, 1994.
3. DIMENSIONS D AND E DO NOT INCLUDE MOLD PROTRUSION.
4. MAXIMUM MOLD PROTRUSION 0.15 PER SIDE.
5. DIMENSION B DOES NOT INCLUDE DAMBAR PROTRUSION. ALLOWABLE PROTRUSION SHALL BE 0.13 TOTAL IN EXCESS OF B DIMENSION AT MAXIMUM MATERIAL CONDITION.

DIM	MILLIMETERS	
	MIN	MAX
A	2.35	2.65
A1	0.10	0.25
B	0.35	0.49
C	0.23	0.32
D	12.65	12.95
E	7.40	7.60
e	1.27 BSC	
H	10.05	10.55
h	0.25	0.75
L	0.50	0.90
θ	0°	7°

ECLinPS are registered trademarks of Semiconductor Components Industries, LLC (SCILLC).

ON Semiconductor and are registered trademarks of Semiconductor Components Industries, LLC (SCILLC). SCILLC reserves the right to make changes without further notice to any products herein. SCILLC makes no warranty, representation or guarantee regarding the suitability of its products for any particular purpose, nor does SCILLC assume any liability arising out of the application or use of any product or circuit, and specifically disclaims any and all liability, including without limitation special, consequential or incidental damages. "Typical" parameters which may be provided in SCILLC data sheets and/or specifications can and do vary in different applications and actual performance may vary over time. All operating parameters, including "Typicals" must be validated for each customer application by customer's technical experts. SCILLC does not convey any license under its patent rights nor the rights of others. SCILLC products are not designed, intended, or authorized for use as components in systems intended for surgical implant into the body, or other applications intended to support or sustain life, or for any other application in which the failure of the SCILLC product could create a situation where personal injury or death may occur. Should Buyer purchase or use SCILLC products for any such unintended or unauthorized application, Buyer shall indemnify and hold SCILLC and its officers, employees, subsidiaries, affiliates, and distributors harmless against all claims, costs, damages, and expenses, and reasonable attorney fees arising out of, directly or indirectly, any claim of personal injury or death associated with such unintended or unauthorized use, even if such claim alleges that SCILLC was negligent regarding the design or manufacture of the part. SCILLC is an Equal Opportunity/Affirmative Action Employer. This literature is subject to all applicable copyright laws and is not for resale in any manner.

### PUBLICATION ORDERING INFORMATION

**LITERATURE FULFILLMENT:**

Literature Distribution Center for ON Semiconductor  
P.O. Box 61312, Phoenix, Arizona 85082-1312 USA  
Phone: 480-829-7710 or 800-344-3860 Toll Free USA/Canada  
Fax: 480-829-7709 or 800-344-3867 Toll Free USA/Canada  
Email: orderlit@onsemi.com

**N. American Technical Support:** 800-282-9855 Toll Free USA/Canada

**Japan:** ON Semiconductor, Japan Customer Focus Center  
2-9-1 Kamimeguro, Meguro-ku, Tokyo, Japan 153-0051  
Phone: 81-3-5773-3850

**ON Semiconductor Website:** <http://onsemi.com>

**Order Literature:** <http://www.onsemi.com/litorder>

For additional information, please contact your local Sales Representative.