

MC100LVEL92

5V Triple PECL Input to LVPECL Output Translator

The MC100LVEL92 is a triple PECL input to LVPECL output translator. The device receives standard PECL signals and translates them to differential LVPECL output signals.

To accomplish the PECL to LVPECL level translation, the MC100LVEL92 requires three power rails. The V_{CC} supply is to be connected to the standard 5 V PECL supply, the LV_{CC} supply is to be connected to the 3.3 V LVPECL supply, and Ground is connected to the system ground plane. Both the V_{CC} and LV_{CC} should be bypassed to ground with 0.01 μ F capacitors.

The PECL V_{BB} pin, an internally generated voltage supply, is available to this device only. For single-ended input conditions, the unused differential input is connected to V_{BB} as a switching reference voltage. V_{BB} may also rebias AC coupled inputs. When used, decouple V_{BB} and V_{CC} via a 0.01 μ F capacitor and limit current sourcing or sinking to 0.5 mA. When not used, V_{BB} should be left open.

- 500 ps Propagation Delays
- 5 V and 3.3 V Supplies Required
- ESD Protection: Human Body Model; >2 kV, Machine Model; >200 V
- The 100 Series Contains Temperature Compensation
- LVPECL Operating Range: $LV_{CC} = 3.0$ V to 3.8 V
- PECL Operating Range: $V_{CC} = 4.5$ V to 5.5 V
- Internal Input Pulldown Resistors
- Q Output will Default LOW with Inputs Open or < GND + 1.3 V
- Meets or Exceeds JEDEC Spec EIA/JESD78 IC Latchup Test
- Moisture Sensitivity Level 1
- For Additional Information, see Application Note AND8003/D
- Flammability Rating: UL 94 V-0 @ 0.125 in, Oxygen Index 28 to 34
- Transistor Count = 247 devices
- Pb-Free Package is Available*



ON Semiconductor®

<http://onsemi.com>

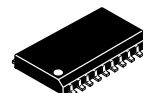

SO-20 WB
DW SUFFIX
CASE 751D

MARKING DIAGRAM*

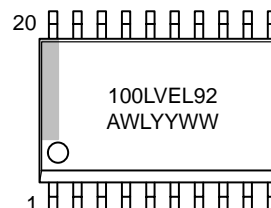

A = Assembly Location
WL = Wafer Lot
YY = Year
WW = Work Week

*For additional marking information, refer to Application Note AND8002/D.

ORDERING INFORMATION

See detailed ordering and shipping information in the package dimensions section on page 5 of this data sheet.

*For additional information on our Pb-Free strategy and soldering details, please download the ON Semiconductor Soldering and Mounting Techniques Reference Manual, SOLDERRM/D.

MC100LVEL92

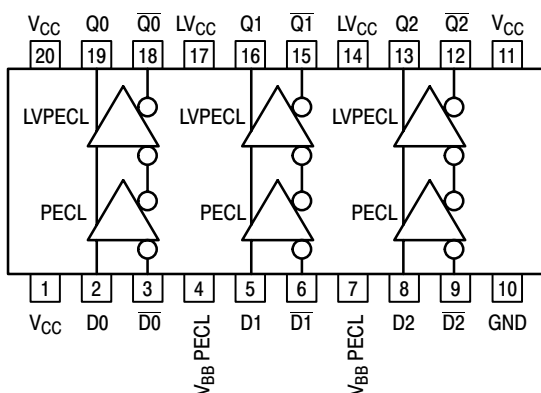

Table 1. PIN DESCRIPTION

PIN	FUNCTION
Dn, \overline{Dn}	PECL Inputs
Qn, \overline{Qn}	LVPECL Outputs
PECL V_{BB}	PECL Reference Voltage Output
LVCC	LVPECL Power Supply
VCC	PECL Power Supply
GND	Common Ground Rail

Warning: All VCC, LVCC, and GND pins must be externally connected to Power Supply to guarantee proper operation.

Figure 1. Logic Diagram and Pinout: SO-20 WB (Top View)

Table 2. MAXIMUM RATINGS

Symbol	Parameter	Condition 1	Condition 2	Rating	Unit
VCC	PECL Power Supply	GND = 0 V		8 to 0	V
LVCC	LVPECL Power Supply	GND = 0 V		8 to 0	V
V _I	PECL Input Voltage	GND = 0 V	V _I ≤ VCC	6 to 0	V
I _{out}	Output Current	Continuous Surge		50 100	mA mA
I _{BB}	PECL V _{BB} Sink/Source			± 0.5	mA
T _A	Operating Temperature Range			-40 to +85	°C
T _{stg}	Storage Temperature Range			-65 to +150	°C
θ _{JA}	Thermal Resistance (Junction-to-Ambient)	0 lfp 500 lfp	SOIC-20 WB SOIC-20 WB	90 60	°C/W °C/W
θ _{JC}	Thermal Resistance (Junction-to-Case)	Standard Board	SOIC-20 WB	30 to 35	°C/W
T _{sol}	Wave Solder	<2 to 3 sec @ 248°C		265	°C

Maximum ratings are those values beyond which device damage can occur. Maximum ratings applied to the device are individual stress limit values (not normal operating conditions) and are not valid simultaneously. If these limits are exceeded, device functional operation is not implied, damage may occur and reliability may be affected.

MC100LEVEL92

Table 3. PECL INPUT DC CHARACTERISTICS $V_{CC} = 5.0\text{ V}$; $LV_{CC} = 3.3\text{ V}$; $GND = 0\text{ V}$ (Note 1)

Symbol	Characteristic	-40°C			25°C			85°C			Unit
		Min	Typ	Max	Min	Typ	Max	Min	Typ	Max	
$I_{V_{CC}}$	PECL Power Supply Current			12			12			12	mA
V_{IH}	Input HIGH Voltage (Single-Ended)	3835		4120	3835		4120	3835		4120	mV
V_{IL}	Input LOW Voltage (Single-Ended)	3190		3515	3190		3525	3190		3525	mV
PECL V_{BB}	Output Voltage Reference	3.62		3.74	3.62		3.74	3.62		3.74	V
V_{IHCMR}	Input HIGH Voltage Common Mode Range (Differential) (Note 2) $V_{pp} < 500\text{ mV}$ $V_{pp} \geq 500\text{ mV}$	1.3 1.5		4.8 4.8	1.2 1.4		4.8 4.8	1.2 1.4		4.8 4.8	V V
I_{IH}	Input HIGH Current			150			150			150	μA
I_{IL}	Input LOW Current	$\frac{D}{\bar{D}}$ 0.5 -600			0.5 -600			0.5 -600			μA

NOTE: Device will meet the specifications after thermal equilibrium has been established when mounted in a test socket or printed circuit board with maintained transverse airflow greater than 500 lfm. Electrical parameters are guaranteed only over the declared operating temperature range. Functional operation of the device exceeding these conditions is not implied. Device specification limit values are applied individually under normal operating conditions and not valid simultaneously.

- Input parameters vary 1:1 with V_{CC} . V_{CC} can vary 4.5 V to 5.5 V.
- V_{IHCMR} min varies 1:1 with GND. V_{IHCMR} max varies 1:1 with V_{CC} . The V_{IHCMR} range is referenced to the most positive side of the differential input signal. Normal operation is obtained if the HIGH level falls within the specified range and the peak-to-peak voltage lies between V_{ppmin} and 1.0 V.

Table 4. LVPECL OUTPUT DC CHARACTERISTICS $V_{CC} = 5.0\text{ V}$; $LV_{CC} = 3.3\text{ V}$; $GND = 0\text{ V}$ (Note 3)

Symbol	Characteristic	-40°C			25°C			85°C			Unit
		Min	Typ	Max	Min	Typ	Max	Min	Typ	Max	
$I_{LV_{CC}}$	LVPECL Power Supply Current			20			20			21	mA
V_{OH}	Output HIGH Voltage (Note 4)	2215	2295	2420	2275	2345	2420	2275	2345	2420	mV
V_{OL}	Output LOW Voltage (Note 4)	1470	1605	1745	1490	1595	1680	1490	1595	1680	mV

NOTE: Device will meet the specifications after thermal equilibrium has been established when mounted in a test socket or printed circuit board with maintained transverse airflow greater than 500 lfm. Electrical parameters are guaranteed only over the declared operating temperature range. Functional operation of the device exceeding these conditions is not implied. Device specification limit values are applied individually under normal operating conditions and not valid simultaneously.

- Output parameters vary 1:1 with LV_{CC} . V_{CC} can vary 3.0 V to 3.8 V.
- Outputs are terminated through a 50 Ω resistor to $LV_{CC} - 2.0\text{ V}$.

MC100LEVEL92

Table 5. AC CHARACTERISTICS $V_{CC} = 5.0\text{ V}$; $LV_{CC} = 3.3\text{ V}$; $GND = 0\text{ V}$ (Note 5)

Symbol	Characteristic	-40°C			25°C			85°C			Unit
		Min	Typ	Max	Min	Typ	Max	Min	Typ	Max	
f_{max}	Maximum Toggle Frequency		TBD			TBD			TBD		GHz
t_{PLH} t_{PHL}	Propagation Delay D to Q	490 440	590 590	690 740	510 460	610 610	710 760	530 480	630 630	730 780	ps
t_{SKEW}	Skew Output-to-Output (Note 6) Part-to-Part (Diff) (Note 6) Duty Cycle (Diff) (Note 7)		20 20 25	100 200		20 20 25	100 200		20 20 25	100 200	ps
t_{JITTER}	Cycle-to-Cycle Jitter		TBD			TBD			TBD		ps
V_{PP}	Input Swing (Note 8)	150		1000	150		1000	150		1000	mV
t_r t_f	Output Rise/Fall Times Q (20% – 80%)	270		530	270		530	270		530	ps

NOTE: Device will meet the specifications after thermal equilibrium has been established when mounted in a test socket or printed circuit board with maintained transverse airflow greater than 500 lfpm. Electrical parameters are guaranteed only over the declared operating temperature range. Functional operation of the device exceeding these conditions is not implied. Device specification limit values are applied individually under normal operating conditions and not valid simultaneously.

5. LV_{CC} can vary 3.0 V to 3.8 V; V_{CC} can vary 4.5 V to 5.5 V. Outputs are terminated through a 50 Ω resistor to $LV_{CC} - 2.0\text{ V}$.
6. Skews are valid across specified voltage range, part-to-part skew is for a given temperature.
7. Duty cycle skew is the difference between a t_{PLH} and t_{PHL} propagation delay through a device.
8. $V_{PP}(\min)$ is the minimum input swing for which AC parameters are guaranteed. The device has a DC gain of ≈ 40 .

MC100LVEL92

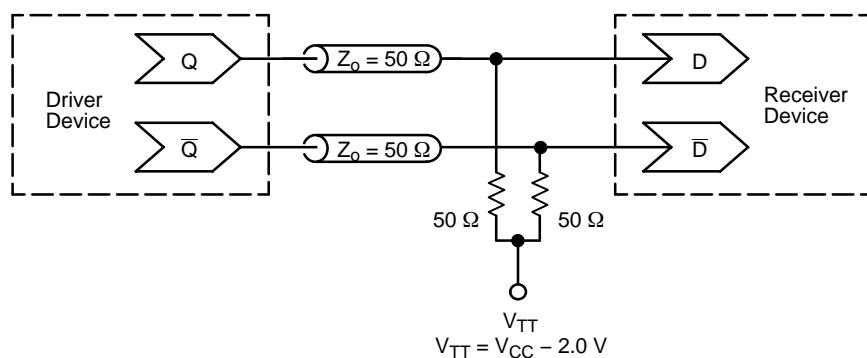

**Figure 2. Typical Termination for Output Driver and Device Evaluation
(See Application Note AND8020/D – Termination of ECL Logic Devices.)**

ORDERING INFORMATION

Device	Package	Shipping†
MC100LVEL92DW	SO-20 WB	38 Units / Rail
MC100LVEL92DWR2	SO-20 WB	1000 / Tape & Reel
MC100LVEL92DWR2G	SO-20 WB (Pb-Free)	1000 / Tape & Reel

†For information on tape and reel specifications, including part orientation and tape sizes, please refer to our Tape and Reel Packaging Specifications Brochure, BRD8011/D.

Resource Reference of Application Notes

- AN1405/D** – ECL Clock Distribution Techniques
- AN1406/D** – Designing with PECL (ECL at +5.0 V)
- AN1503/D** – ECLinPS™ I/O SPICE Modeling Kit
- AN1504/D** – Metastability and the ECLinPS Family
- AN1568/D** – Interfacing Between LVDS and ECL
- AN1642/D** – The ECL Translator Guide
- AND8001/D** – Odd Number Counters Design
- AND8002/D** – Marking and Date Codes
- AND8020/D** – Termination of ECL Logic Devices
- AND8066/D** – Interfacing with ECLinPS
- AND8090/D** – AC Characteristics of ECL Devices

MC100LVEL92

PACKAGE DIMENSIONS

SO-20 WB
DW SUFFIX
CASE 751D-05
ISSUE G

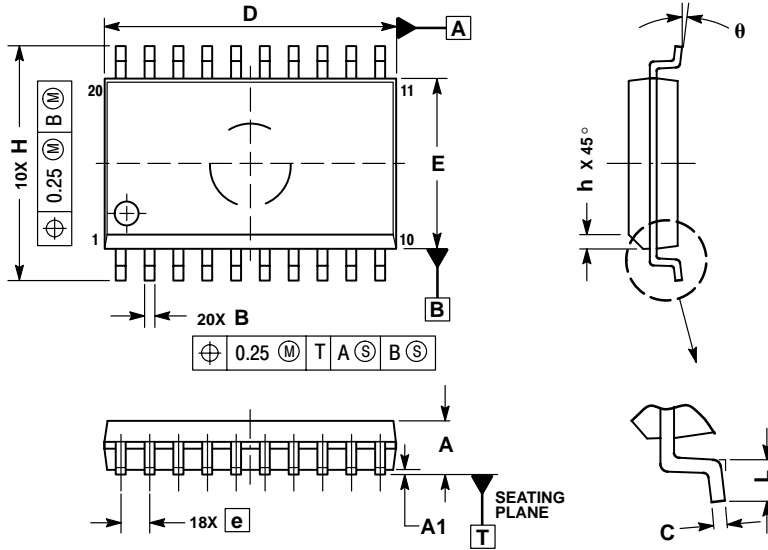

NOTES:

1. DIMENSIONS ARE IN MILLIMETERS.
2. INTERPRET DIMENSIONS AND TOLERANCES PER ASME Y14.5M, 1994.
3. DIMENSIONS D AND E DO NOT INCLUDE MOLD PROTRUSION.
4. MAXIMUM MOLD PROTRUSION 0.15 PER SIDE.
5. DIMENSION B DOES NOT INCLUDE DAMBAR PROTRUSION. ALLOWABLE PROTRUSION SHALL BE 0.13 TOTAL IN EXCESS OF B DIMENSION AT MAXIMUM MATERIAL CONDITION.

DIM	MILLIMETERS	
	MIN	MAX
A	2.35	2.65
A1	0.10	0.25
B	0.35	0.49
C	0.23	0.32
D	12.65	12.95
E	7.40	7.60
e	1.27 BSC	
H	10.05	10.55
h	0.25	0.75
L	0.50	0.90
θ	0°	7°

ECLinPS are registered trademarks of Semiconductor Components Industries, LLC (SCILLC).

ON Semiconductor and  are registered trademarks of Semiconductor Components Industries, LLC (SCILLC). SCILLC reserves the right to make changes without further notice to any products herein. SCILLC makes no warranty, representation or guarantee regarding the suitability of its products for any particular purpose, nor does SCILLC assume any liability arising out of the application or use of any product or circuit, and specifically disclaims any and all liability, including without limitation special, consequential or incidental damages. "Typical" parameters which may be provided in SCILLC data sheets and/or specifications can and do vary in different applications and actual performance may vary over time. All operating parameters, including "Typicals" must be validated for each customer application by customer's technical experts. SCILLC does not convey any license under its patent rights nor the rights of others. SCILLC products are not designed, intended, or authorized for use as components in systems intended for surgical implant into the body, or other applications intended to support or sustain life, or for any other application in which the failure of the SCILLC product could create a situation where personal injury or death may occur. Should Buyer purchase or use SCILLC products for any such unintended or unauthorized application, Buyer shall indemnify and hold SCILLC and its officers, employees, subsidiaries, affiliates, and distributors harmless against all claims, costs, damages, and expenses, and reasonable attorney fees arising out of, directly or indirectly, any claim of personal injury or death associated with such unintended or unauthorized use, even if such claim alleges that SCILLC was negligent regarding the design or manufacture of the part. SCILLC is an Equal Opportunity/Affirmative Action Employer. This literature is subject to all applicable copyright laws and is not for resale in any manner.

PUBLICATION ORDERING INFORMATION

LITERATURE FULFILLMENT:

Literature Distribution Center for ON Semiconductor
P.O. Box 61312, Phoenix, Arizona 85082-1312 USA
Phone: 480-829-7710 or 800-344-3860 Toll Free USA/Canada
Fax: 480-829-7709 or 800-344-3867 Toll Free USA/Canada
Email: orderlit@onsemi.com

N. American Technical Support: 800-282-9855 Toll Free USA/Canada

Japan: ON Semiconductor, Japan Customer Focus Center
2-9-1 Kamimeguro, Meguro-ku, Tokyo, Japan 153-0051
Phone: 81-3-5773-3850

ON Semiconductor Website: <http://onsemi.com>

Order Literature: <http://www.onsemi.com/litorder>

For additional information, please contact your local Sales Representative.