

SWITCHMODE™ Series NPN Silicon Power Transistors

These transistors are designed for high-voltage, high-speed switching of inductive circuits where fall time and RBSOA are critical. They are particularly well-suited for line-operated switchmode applications.

The MJE16004 is a high-gain version of the MJE16002 and MJH16002 for applications where drive current is limited.

Typical Applications:

- Switching Regulators
- High Resolution Deflection Circuits
- Inverters
- Motor Drives
- Fast Switching Speeds
 - 50 ns Inductive Fall Time @ 75°C (Typ)
 - 70 ns Crossover Time @ 75°C (Typ)
- 100°C Performance Specified for:
 - Reverse-Biased SOA
 - Inductive Switching Times
 - Saturation Voltages
 - Leakage Currents

MJE16002*
MJE16004*

*ON Semiconductor Preferred Device

**5.0 AMPERE
NPN SILICON
POWER TRANSISTORS
450 VOLTS
80 WATTS**

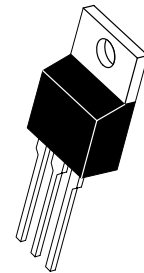

**CASE 221A-09
TO-220AB**

MAXIMUM RATINGS

Rating	Symbol	Value	Unit
Collector-Emitter Voltage	$V_{CEO(sus)}$	450	Vdc
Collector-Emitter Voltage	V_{CEV}	850	Vdc
Emitter-Base Voltage	V_{EB}	6.0	Vdc
Collector Current — Continuous — Peak (1)	I_C I_{CM}	5.0 10	Adc
Base Current — Continuous — Peak (1)	I_B I_{BM}	4.0 8.0	Adc
Total Power Dissipation @ $T_C = 25^\circ\text{C}$ @ $T_C = 100^\circ\text{C}$ Derate above $T_C = 25^\circ\text{C}$	P_D	80 32 0.64	Watts W/°C
Operating and Storage Junction Temperature Range	T_J, T_{stg}	-65 to +150	°C

THERMAL CHARACTERISTICS

Characteristic	Symbol	Max	Unit
Thermal Resistance, Junction to Case	$R_{\theta JC}$	1.56	°C/W
Lead Temperature for Soldering Purposes: 1/8" from Case for 5 Seconds	T_L	275	°C

(1) Pulse Test: Pulse Width = 5 ms, Duty Cycle ≤ 10%.

Preferred devices are ON Semiconductor recommended choices for future use and best overall value.

MJE16002 MJE16004

ELECTRICAL CHARACTERISTICS (T_C = 25°C unless otherwise noted)

Characteristic	Symbol	Min	Typ	Max	Unit
----------------	--------	-----	-----	-----	------

OFF CHARACTERISTICS (1)

Collector–Emitter Sustaining Voltage (Table 2) (I _C = 100 mA, I _B = 0)	V _{CEO(sus)}	450	—	—	Vdc
Collector Cutoff Current (V _{CEV} = 850 Vdc, V _{BE(off)} = 1.5 Vdc) (V _{CEV} = 850 Vdc, V _{BE(off)} = 1.5 Vdc, T _C = 100°C)	I _{CEV}	—	—	0.25 1.5	mAdc
Collector Cutoff Current (V _{CE} = 850 Vdc, R _{BE} = 50 Ω, T _C = 100°C)	I _{CER}	—	—	2.5	mAdc
Emitter Cutoff Current (V _{EB} = 6.0 Vdc, I _C = 0)	I _{EBO}	—	—	1.0	mAdc

SECOND BREAKDOWN

Second Breakdown Collector Current with Base Forward Biased	I _{S/b}	See Figure 17 or 18			
Clamped Inductive SOA with Base Reverse Biased	RBSOA	See Figure 19			

ON CHARACTERISTICS (1)

Collector–Emitter Saturation Voltage (I _C = 1.5 Adc, I _B = 0.2 Adc) MJE16002 (I _C = 1.5 Adc, I _B = 0.15 Adc) MJE16004 (I _C = 3.0 Adc, I _B = 0.4 Adc) MJE16002 (I _C = 3.0 Adc, I _B = 0.3 Adc) MJE16004 (I _C = 3.0 Adc, I _B = 0.4 Adc, T _C = 100°C) MJE16002 (I _C = 3.0 Adc, I _B = 0.3 Adc, T _C = 100°C) MJE16004	V _{CE(sat)}	—	—	1.0 1.0 2.5 2.5 2.5 2.5	Vdc
Base–Emitter Saturation Voltage (I _C = 3.0 Adc, I _B = 0.4 Adc) MJE16002 (I _C = 3.0 Adc, I _B = 0.3 Adc) MJE16004 (I _C = 3.0 Adc, I _S = 0.4 Adc, T _C = 100°C) MJE16002 (I _C = 3.0 Adc, I _B = 0.3 Adc, T _C = 100°C) MJE16004	V _{BE(sat)}	—	—	1.5 1.5 1.5 1.5	Vdc
DC Current Gain (I _C = 5.0 Adc, V _{CE} = 5.0 Vdc) MJE16002 MJE16004	h _{FE}	5.0 7.0	— —	— —	—

DYNAMIC CHARACTERISTICS

Output Capacitance (V _{CB} = 10 Vdc, I _E = 0, f _{test} = 1.0 kHz)	C _{ob}	—	—	200	pF
---	-----------------	---	---	-----	----

SWITCHING CHARACTERISTICS

Resistive Load (Table 1) MJE16002/MJH10002							
Delay Time	(I _C = 3.0 Adc, V _{CC} = 250 Vdc, I _{B1} = 0.4 Adc, PW = 30 μs, Duty Cycle ≤ 2.0%)	(I _{B2} = 0.8 Adc, R _{B2} = 8.0 Ω)	t _d	—	30	100	ns
Rise Time			t _r	—	100	300	
Storage Time			t _s	—	1000	3000	
Fall Time			t _f	—	60	300	
Storage Time		(V _{BE(off)} = 5.0 Vdc)	t _s	—	400	—	
Fall Time			t _f	—	130	—	
Resistive Load (Table 1) MJE16004/MJH16004							
Delay Time	(I _C = 3.0 Adc, V _{CC} = 250 Vdc, I _{B1} = 0.3 Adc, PW = 30 μs, Duty Cycle ≤ 2.0%)	(I _{B2} = 0.6 Adc, R _{B2} = 8.0 Ω)	t _d	—	30	100	ns
Rise Time			t _r	—	130	300	
Storage Time			t _s	—	800	2700	
Fall Time			t _f	—	80	350	
Storage Time		(V _{BE(off)} = 5.0 Vdc)	t _s	—	250	—	
Fall Time			t _f	—	60	—	

(1) Pulse Test: PW = 300 μs, Duty Cycle ≤ 2%.

MJE16002 MJE16004

SWITCHING CHARACTERISTICS (continued)

Characteristics		Symbol	Min	Typ	Max	Unit	
Inductive Load (Table 2) MJE16002							
Storage Time	$I_C = 3.0 \text{ Adc}$, $I_{B1} = 0.4 \text{ Adc}$, $V_{BE(\text{off})} = 5.0 \text{ Vdc}$, $V_{CE(\text{pk})} = 400 \text{ Vdc}$	$(T_J = 100^\circ\text{C})$	t_{sv}	—	500	1600	ns
Fall Time			t_{fi}	—	100	200	
Crossover Time			t_c	—	120	250	
Storage Time		$(T_J = 150^\circ\text{C})$	t_{sv}	—	600	—	
Fall Time			t_{fi}	—	120	—	
Crossover Time			t_c	—	160	—	
Inductive Load (Table 2) MJE16004							
Storage Time	$I_C = 3.0 \text{ Adc}$, $I_{B1} = 0.3 \text{ Adc}$, $V_{BE(\text{off})} = 5.0 \text{ Vdc}$, $V_{CE(\text{pk})} = 400 \text{ Vdc}$	$(T_J = 100^\circ\text{C})$	t_{sv}	—	400	1300	ns
Fall Time			t_{fi}	—	80	150	
Crossover Time			t_c	—	90	200	
Storage Time		$(T_J = 150^\circ\text{C})$	t_{sv}	—	450	—	
Fall Time			t_{fi}	—	100	—	
Crossover Time			t_c	—	110	—	

(1) Pulse Test: PW = 300 μs , Duty Cycle $\leq 2\%$.

MJE16002 MJE16004

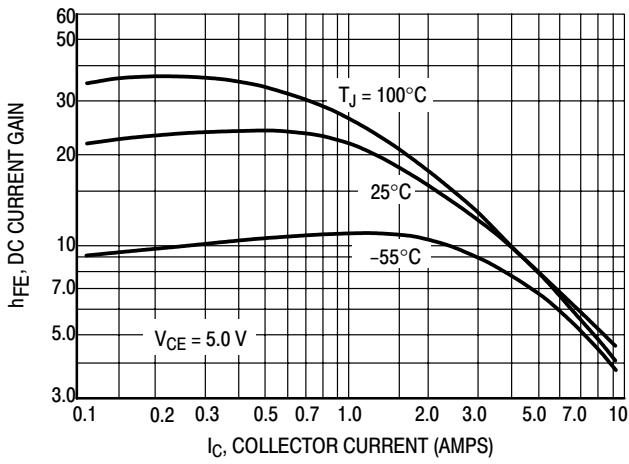

Figure 1. DC Current Gain

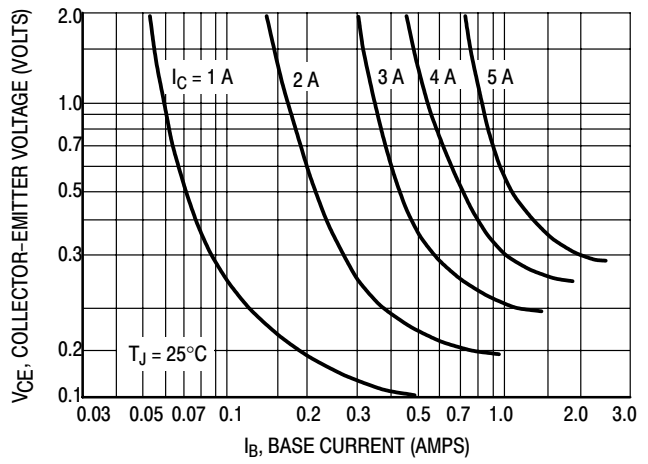

Figure 2. Collector Saturation Region

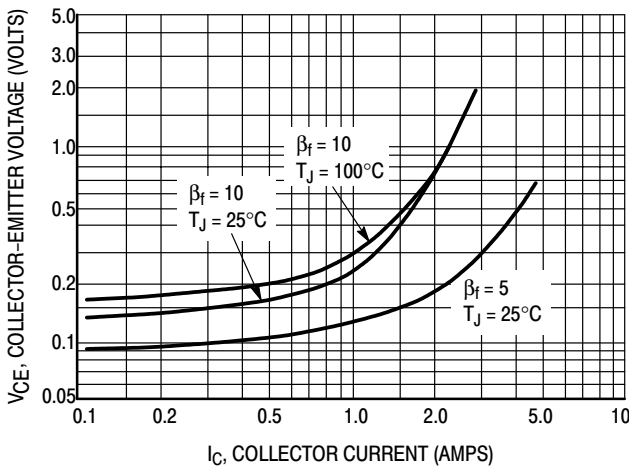

Figure 3. Collector-Emitter Saturation Region

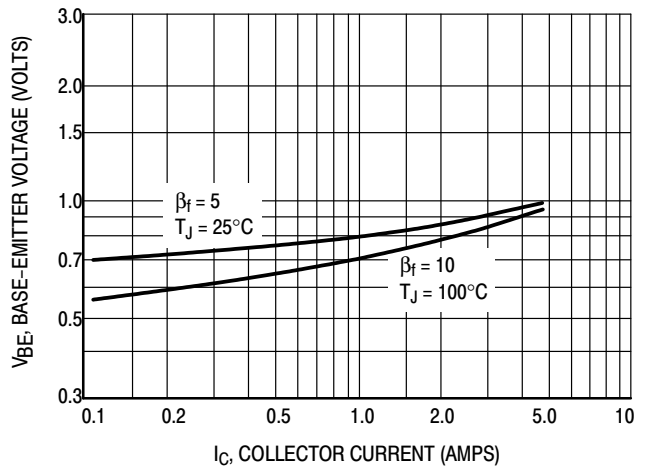

Figure 4. Base-Emitter Voltage

TYPICAL STATIC CHARACTERISTICS (continued)

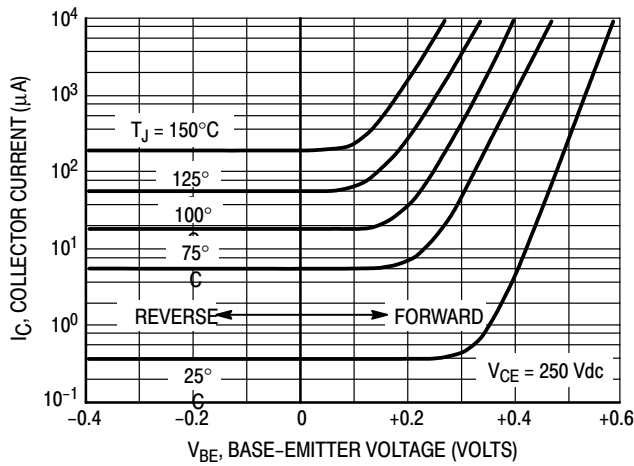

Figure 5. Collector Cutoff Region

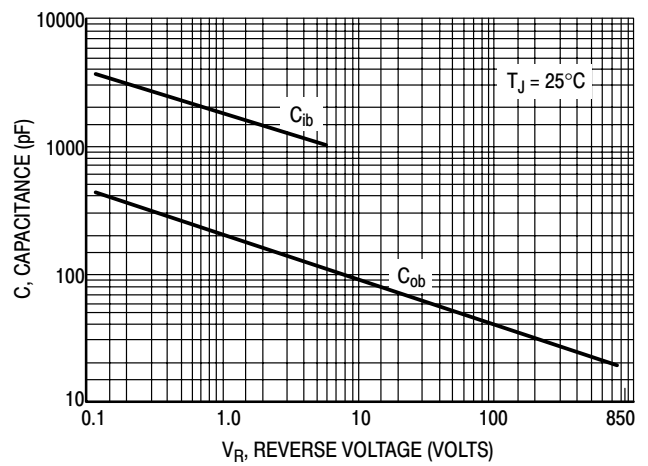

Figure 6. Capacitance

TYPICAL DYNAMIC CHARACTERISTICS

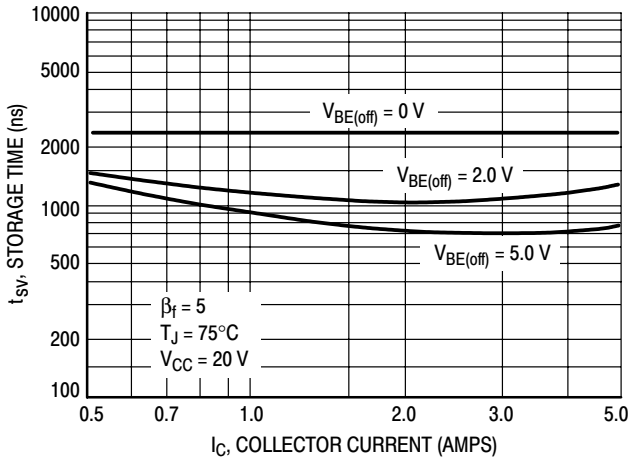

Figure 7. Storage Time

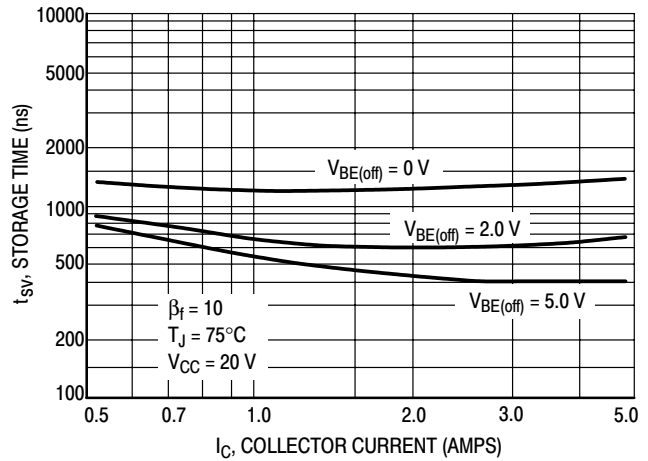

Figure 8. Storage Time

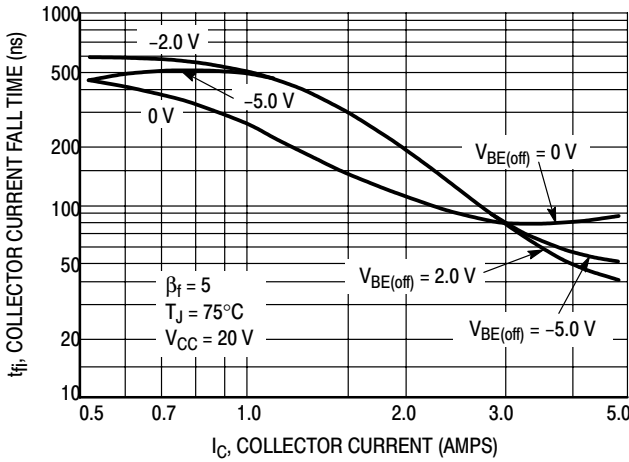

Figure 9. Collector Current Fall Time

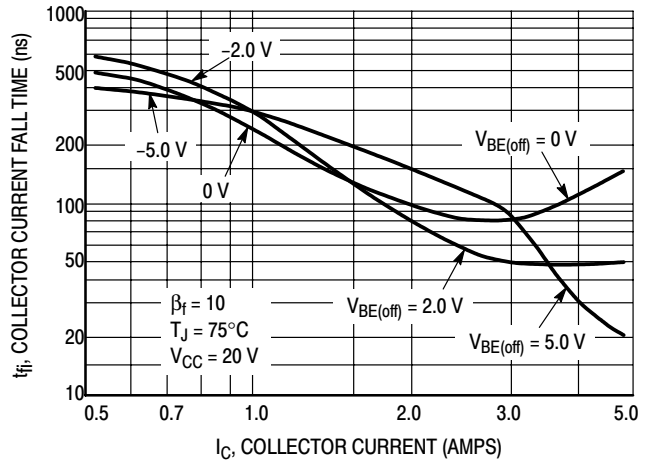

Figure 10. Collector Current Fall Time

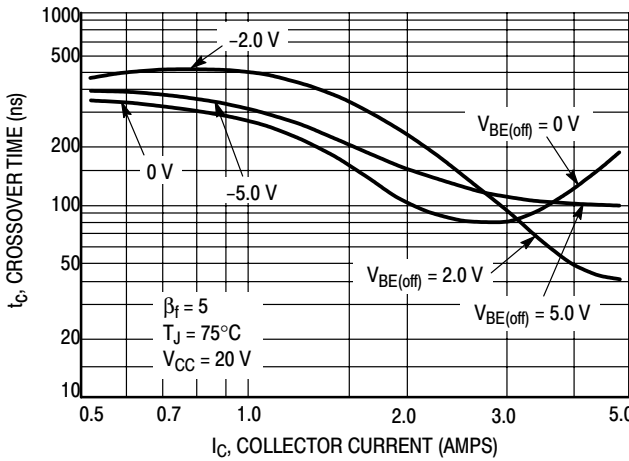

Figure 11. Crossover Time

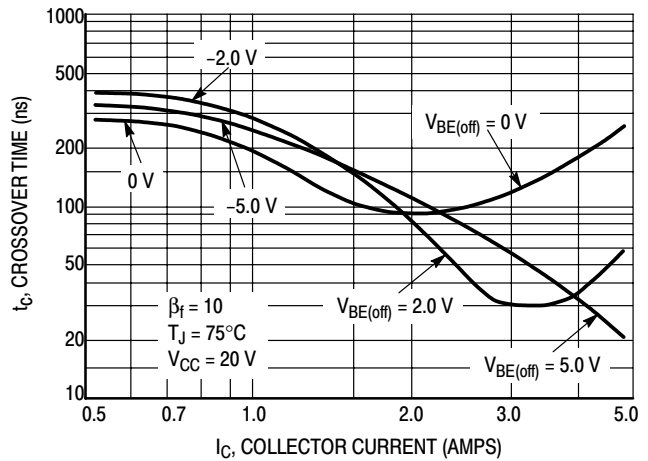

Figure 12. Crossover Time

MJE16002 MJE16004

TYPICAL ELECTRICAL CHARACTERISTICS

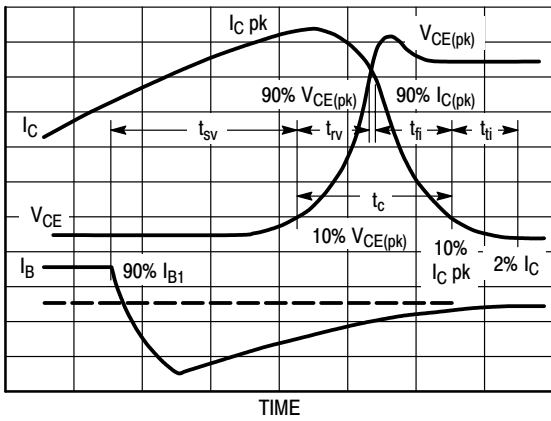

Figure 13. Inductive Switching Measurements

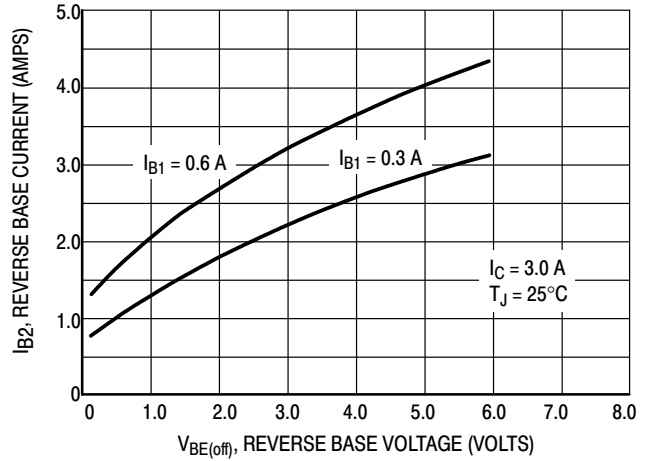

Figure 14. Peak Reverse Base Current

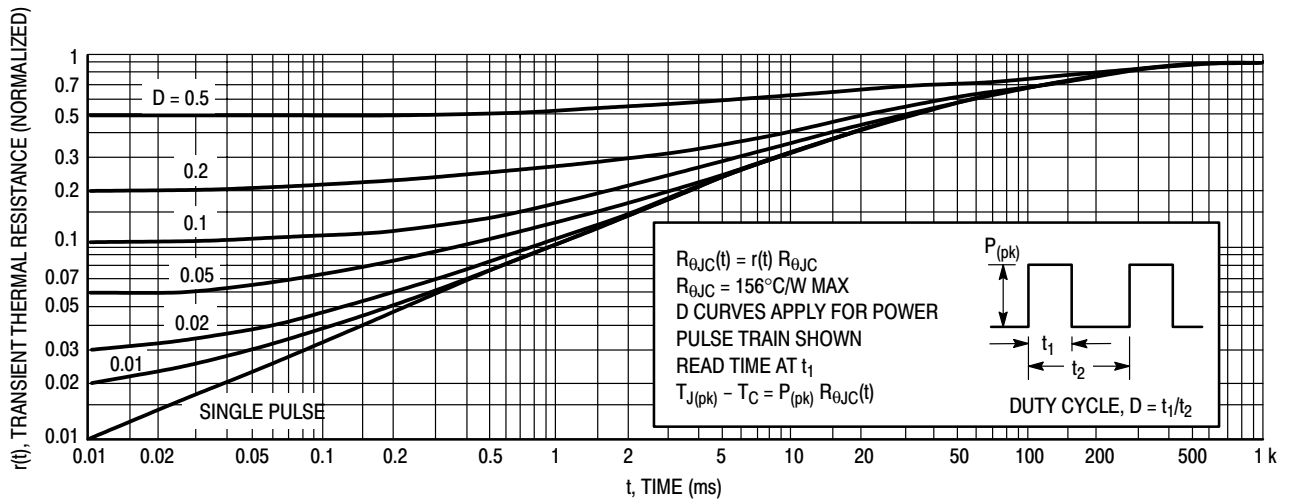

Figure 15. Thermal Response (MJE16002 and MJE16004)

MJE16002 MJE16004

SAFE OPERATING AREA INFORMATION

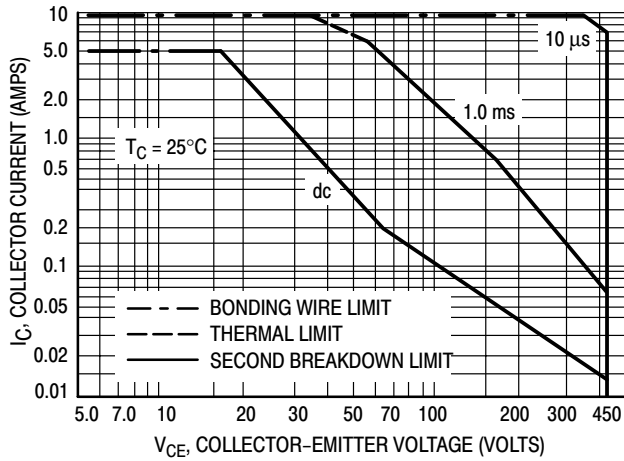

Figure 16. Maximum Rated Forward Bias Safe Operating Area (MJE16002 and MJE16004)

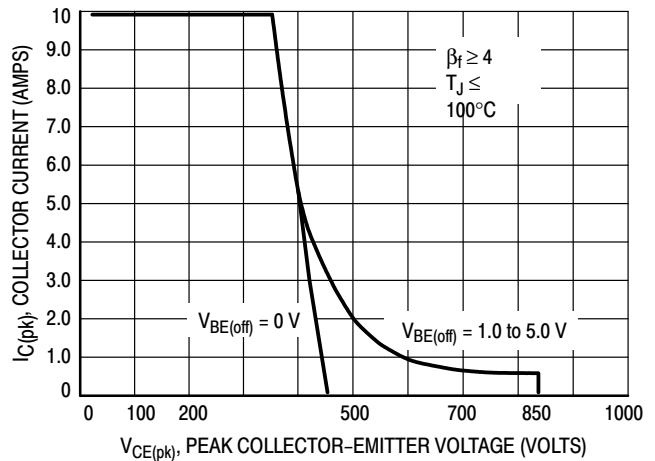

Figure 17. Maximum Rated Reverse Bias Safe Operating Area

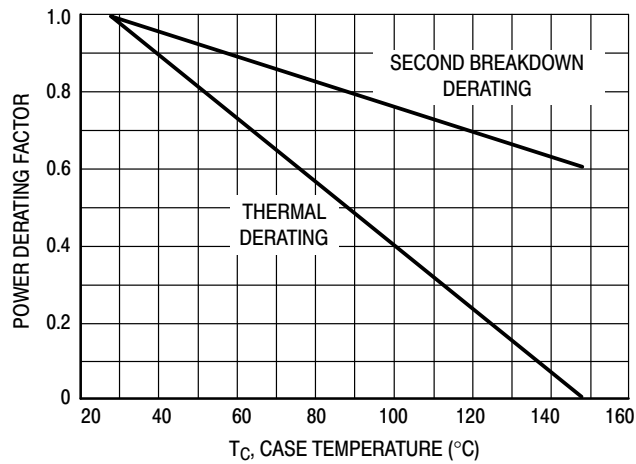

Figure 18. Power Derating

SAFE OPERATING AREA INFORMATION**FORWARD BIAS**

There are two limitations on the power handling ability of a transistor: average junction temperature and second breakdown. Safe operating area curves indicate $I_C - V_{CE}$ limits of the transistor that must be observed for reliable operation; i.e., the transistor must not be subjected to greater dissipation than the curves indicate.

The data of Figure 16 is based on $T_C = 25^\circ\text{C}$; $T_{J(pk)}$ is variable depending on power level. Second breakdown pulse limits are valid for duty cycles to 10% but must be derated when $T_C \geq 25^\circ\text{C}$. Second breakdown limitations do not derate the same as thermal limitations. Allowable current at the voltages shown on Figures 17 and 18 may be found at any case temperature by using the appropriate curve on Figure 20.

$T_{J(pk)}$ may be calculated from the data in Figure 15. At high case temperatures, thermal limitations will reduce the power that can be handled to values less than the limitations imposed by second breakdown.

REVERSE BIAS

For inductive loads, high voltage and high current must be sustained simultaneously during turn-off, in most cases, with the base-to-emitter junction reverse biased. Under these conditions the collector voltage must be held to a safe level at or below a specific value of collector current. This can be accomplished by several means such as active clamping, RC snubbing, load line shaping, etc. The safe level for these devices is specified as Reverse Bias Safe operating Area and represents the voltage-current condition allowable pulling reverse biased turn-off. This rating is verified under clamped conditions so that the device is never subjected to an avalanche mode. Figure 17 gives the RBSOA characteristics.

MJE16002 MJE16004

Table 1. Resistive Load Switching

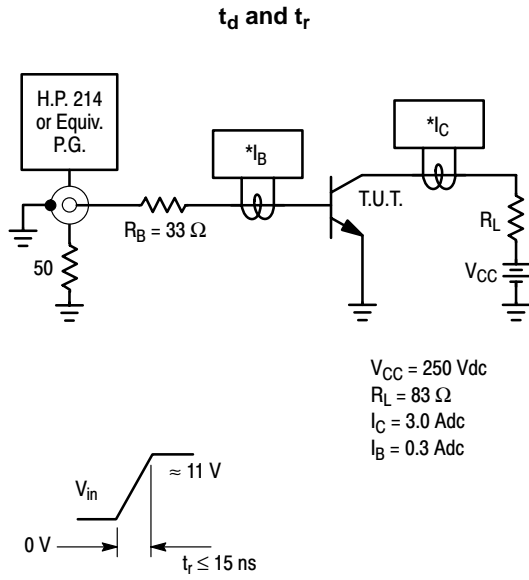

*Tektronix
P-6042 or
Equivalent

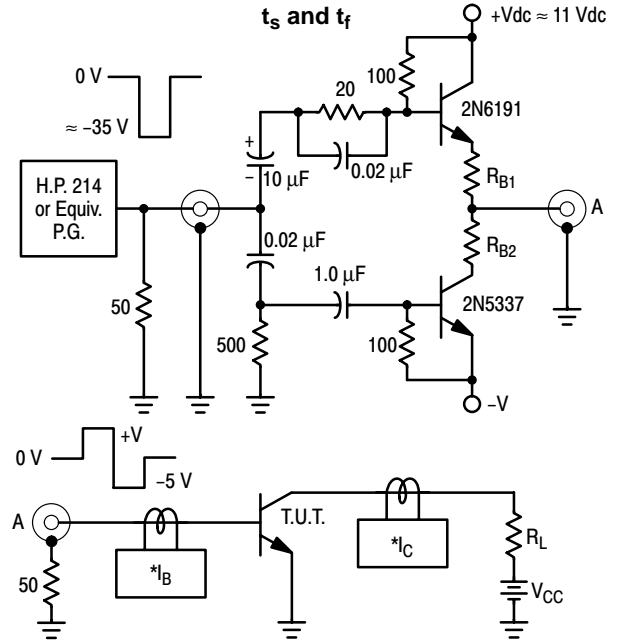

Note: Adjust $-V$ to obtain desired $V_{BE(off)}$ at Point A.

MJE16002 MJE16004

Table 2. Inductive Load Switching

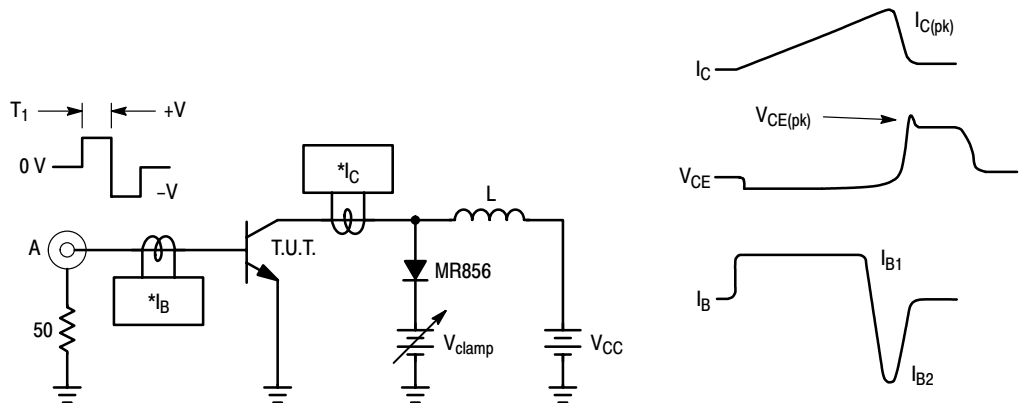
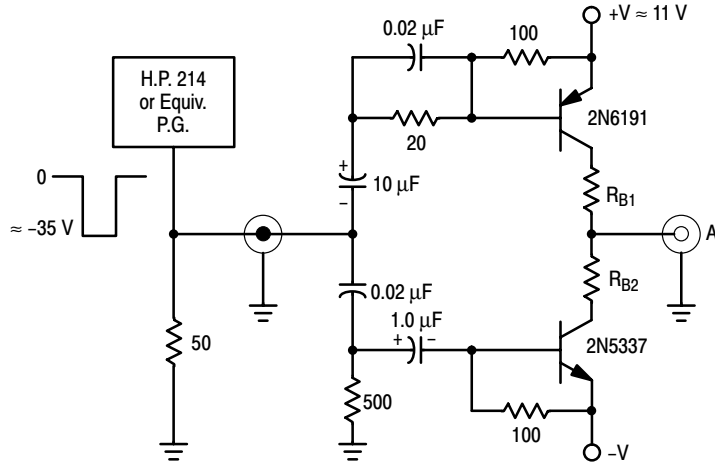

$$T_1 \approx \frac{L_{coil} (I_{Cpk})}{V_{CC}}$$

T₁ adjusted to obtain I_{C(pk)}

V_{CEO(sus)}
L = 10 mH
R_{B2} = ∞
V_{CC} = 20 Volts

Inductive Switching
L = 200 μH
R_{B2} = 0
V_{CC} = 20 Volts
R_{B1} selected for desired I_{B1}

RBSOA
L = 200 μH
R_{B2} = 0
V_{CC} = 20 Volts
R_{B1} selected for desired I_{B1}

*Tektronix
P-6042 or
Equivalent

Scope — Tektronix
7403 or
Equivalent

Note: Adjust -V to obtain desired V_{BE(off)} at Point A.

TYPICAL INDUCTIVE SWITCHING WAVEFORMS

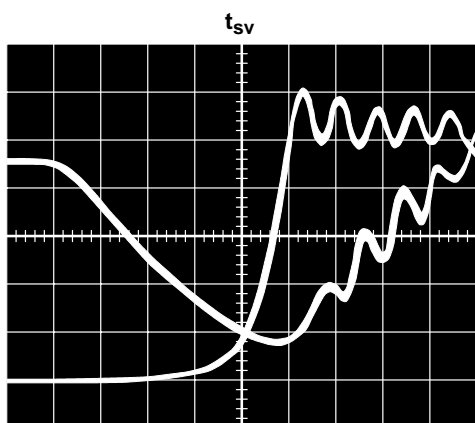

I_{C(pk)} = 3.0 Amps
I_{B1} = 0.3 Amp
V_{BE(off)} = 5.0 Volts
V_{CE(pk)} = 300 Volts
T_C = 25°C
Time Base =
20 ns/cm

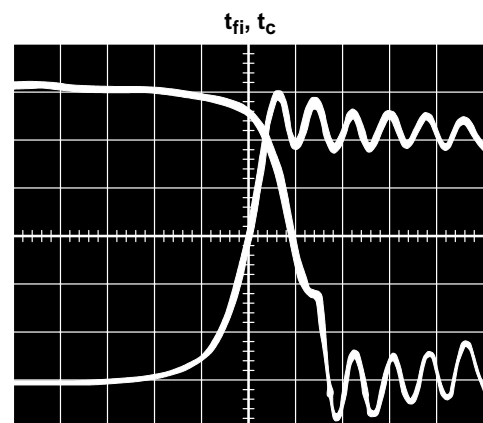

I_{C(pk)} = 3.0 Amps
I_{B1} = 0.3 Amp
V_{BE(off)} = 5.0 Volts
V_{CE(pk)} = 300 Volts
T_C = 25°C
Time Base =
20 ns/cm

MJE16002 MJE16004

PACKAGE DIMENSIONS

TO-220AB
CASE 221A-09
ISSUE AA

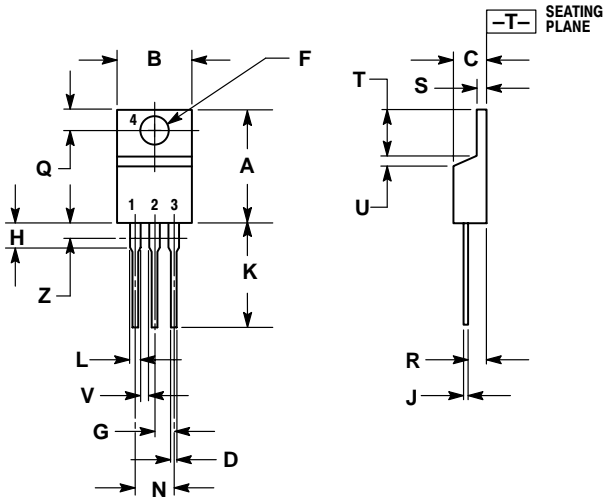

NOTES:

1. DIMENSIONING AND TOLERANCING PER ANSI Y14.5M, 1982.
2. CONTROLLING DIMENSION: INCH.
3. DIMENSION Z DEFINES A ZONE WHERE ALL BODY AND LEAD IRREGULARITIES ARE ALLOWED.

DIM	INCHES		MILLIMETERS	
	MIN	MAX	MIN	MAX
A	0.570	0.620	14.48	15.75
B	0.380	0.405	9.66	10.28
C	0.160	0.190	4.07	4.82
D	0.025	0.035	0.64	0.88
F	0.142	0.147	3.61	3.73
G	0.095	0.105	2.42	2.66
H	0.110	0.155	2.80	3.93
J	0.018	0.025	0.46	0.64
K	0.500	0.562	12.70	14.27
L	0.045	0.060	1.15	1.52
N	0.190	0.210	4.83	5.33
Q	0.100	0.120	2.54	3.04
R	0.080	0.110	2.04	2.79
S	0.045	0.055	1.15	1.39
T	0.235	0.255	5.97	6.47
U	0.000	0.050	0.00	1.27
V	0.045	---	1.15	---
Z	---	0.080	---	2.04

SWITCHMODE is a trademark of Semiconductor Components Industries, LLC.

ON Semiconductor and  are trademarks of Semiconductor Components Industries, LLC (SCILLC). SCILLC reserves the right to make changes without further notice to any products herein. SCILLC makes no warranty, representation or guarantee regarding the suitability of its products for any particular purpose, nor does SCILLC assume any liability arising out of the application or use of any product or circuit, and specifically disclaims any and all liability, including without limitation special, consequential or incidental damages. "Typical" parameters which may be provided in SCILLC data sheets and/or specifications can and do vary in different applications and actual performance may vary over time. All operating parameters, including "Typicals" must be validated for each customer application by customer's technical experts. SCILLC does not convey any license under its patent rights nor the rights of others. SCILLC products are not designed, intended, or authorized for use as components in systems intended for surgical implant into the body, or other applications intended to support or sustain life, or for any other application in which the failure of the SCILLC product could create a situation where personal injury or death may occur. Should Buyer purchase or use SCILLC products for any such unintended or unauthorized application, Buyer shall indemnify and hold SCILLC and its officers, employees, subsidiaries, affiliates, and distributors harmless against all claims, costs, damages, and expenses, and reasonable attorney fees arising out of, directly or indirectly, any claim of personal injury or death associated with such unintended or unauthorized use, even if such claim alleges that SCILLC was negligent regarding the design or manufacture of the part. SCILLC is an Equal Opportunity/Affirmative Action Employer.

PUBLICATION ORDERING INFORMATION

NORTH AMERICA Literature Fulfillment:

Literature Distribution Center for ON Semiconductor
P.O. Box 5163, Denver, Colorado 80217 USA
Phone: 303-675-2175 or 800-344-3860 Toll Free USA/Canada
Fax: 303-675-2176 or 800-344-3867 Toll Free USA/Canada
Email: ONlit@hibbertco.com
Fax Response Line: 303-675-2167 or 800-344-3810 Toll Free USA/Canada

N. American Technical Support: 800-282-9855 Toll Free USA/Canada

EUROPE: LDC for ON Semiconductor – European Support

German Phone: (+1) 303-308-7140 (Mon-Fri 2:30pm to 7:00pm CET)
Email: ONlit-german@hibbertco.com
French Phone: (+1) 303-308-7141 (Mon-Fri 2:00pm to 7:00pm CET)
Email: ONlit-french@hibbertco.com
English Phone: (+1) 303-308-7142 (Mon-Fri 12:00pm to 5:00pm GMT)
Email: ONlit@hibbertco.com

EUROPEAN TOLL-FREE ACCESS*: 00-800-4422-3781

*Available from Germany, France, Italy, UK, Ireland

CENTRAL/SOUTH AMERICA:

Spanish Phone: 303-308-7143 (Mon-Fri 8:00am to 5:00pm MST)
Email: ONlit-spanish@hibbertco.com
Toll-Free from Mexico: Dial 01-800-288-2872 for Access –
then Dial 866-297-9322

ASIA/PACIFIC: LDC for ON Semiconductor – Asia Support

Phone: 1-303-675-2121 (Tue-Fri 9:00am to 1:00pm, Hong Kong Time)
Toll Free from Hong Kong & Singapore:
001-800-4422-3781
Email: ONlit-asia@hibbertco.com

JAPAN: ON Semiconductor, Japan Customer Focus Center

4-32-1 Nishi-Gotanda, Shinagawa-ku, Tokyo, Japan 141-0031
Phone: 81-3-5740-2700
Email: r14525@onsemi.com

ON Semiconductor Website: <http://onsemi.com>

For additional information, please contact your local Sales Representative.