

## Efficient High Power Flash Light

Prepared by: Michael Bairanzade  
ON Semiconductor



ON Semiconductor®

<http://onsemi.com>

### APPLICATION NOTE

#### INTRODUCTION

Although the xenon lamps dominate the standard camera market, they are not applicable in the portable phone. As a matter of fact, the large reservoir capacitor and high voltage associated with the xenon flash make such a concept not suitable for the cellular phone equipments. The semiconductor based White LED devices provide the right choice when limited flash light becomes necessary to illuminate a photographic scene. This paper depicts the basics of the xenon concept and details a typical White LED flash application.

#### XENON LAMP CONCEPT

A low pressure of a rare gas mixture fills a glass envelope with two ends electrodes on both sides. In steady state, the voltage across the electrodes is set to a value well below the trigger voltage as depicted Figure 1. At this point, no current flows and the system is stable until a trigger voltage is applied to the third electrode. This high voltage pulse, in the 1 kV range, comes from a transformer built with a small magnetic core triggered by an abrupt discharge of the capacitor C2 (see Figure 2).

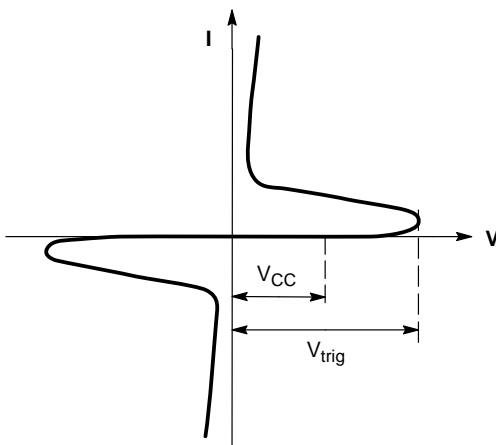

Figure 1. Xenon Flash Breakdown Voltage

The gas is ignited and the plasma generates a bright flash, the typical duration being 2 ms for consumer applications.

Depending upon the type of flash involved, the amount of energy stored into capacitor C1 can be a low 10 Joule (small camera) to thousand of Joule for professional applications.

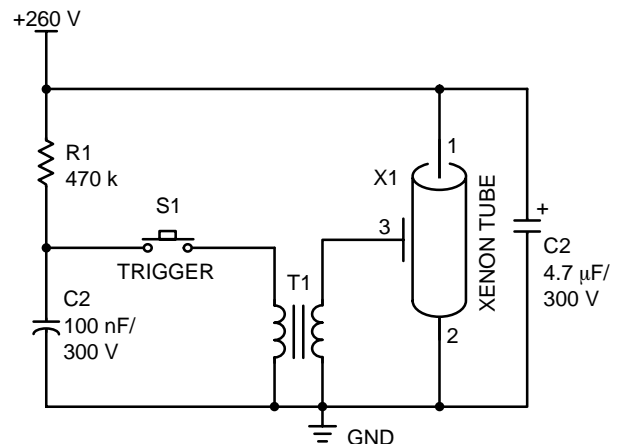

Figure 2. Basic Xenon Flash

The net advantage of such a concept is the very short pulse, making easy snap shot photos to capture moving stuffs. The drawbacks are the large physical size of the reservoir capacitor and the recycle time needed to recharge the capacitor between two shots (in the 5 sec range for consumer applications). Clearly, these drawbacks make the xenon based flash not suitable for hand held cellular phone, with limited size and energy supply.

#### WHITE LED FLASH

To overcome the physical size limitation, the flash concept is to make profit of the high efficiency, in term of light, coming from the modern white LED.

With a 4 V forward drop voltage, such diodes do not need extra high voltage trigger pulse, they are extremely fast to turn ON/OFF and all the associated electronic circuit can be housed inside a standard portable phone. Since the white LED have electrical characteristics similar to the standard LED (see Figure 3), one must provide a constant forward current to control the device.

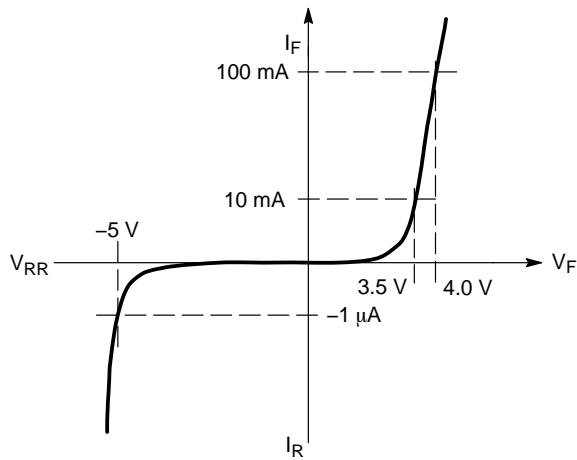

Figure 3. Typical White LED Characteristics

Consequently, a standard voltage source cannot be used straightforward and an extra ballast is necessary to set up the current. On the other hand, the flash must be capable to operate over the typical battery voltage spread (2.8 V to 5.2 V) and a more suitable structure than a simple linear voltage regulator is mandatory. To achieve such constraints, ON Semiconductor has developed a full family of white LED drivers, among which the NCP5007 can fulfill the flash application demands.

**TYPICAL FLASH APPLICATION**

Since the battery voltage ranges from a low 2.8 V to a high 5.2 V, the simplest and economic way to handle this span is to arrange the white LED in series as depicted Figure 4. Such a layout avoid the leakage current during the stand by mode operation (most of the time, the flash is not activated!).

The circuit, built around the NCP5007, is designed to support both the low beam current and the high flash pulse as requested during the capture of a photo.

The DC/DC boost converter, associated to the sense resistor R1, provides a constant current to the load to properly bias the white LEDs. With an internal 200 mV voltage reference (Vref), the chip minimizes the drops along the battery supply path.

**Low Power Beam Operating Mode**

Generally speaking, this mode of operation is used to pre-light the scene to be capture in order to minimize the red-eye effect.

The NMOS transistor Q1 is biased OFF and R1 provides the feedback voltage to regulate the load current. The value of R1 is derived from the Ohm’s law:

$$R1 = \frac{V_{ref}}{I_{out}}$$

With a typical 4 mA operating bias of the LED during the illumination of the scene, the sense resistor is 51 Ω. The current can be dynamically modulated, if necessary, by using the EN signal pin 3 as a digital control: such a mode of operation is depicted in the NCP5007 data sheet. The same pin can be used to control the DC/DC by a bit from the external CPU. Of course, a more powerful light can be provided by setting the sense resistor accordingly.

From a practical stand point, capacitor C2 is mandatory to avoid large spikes during the energy transfers from the inductor L1 and the white LEDs. Moreover, such a capacitor smoothes the current flowing into the LEDs, yielding a better light efficiency.

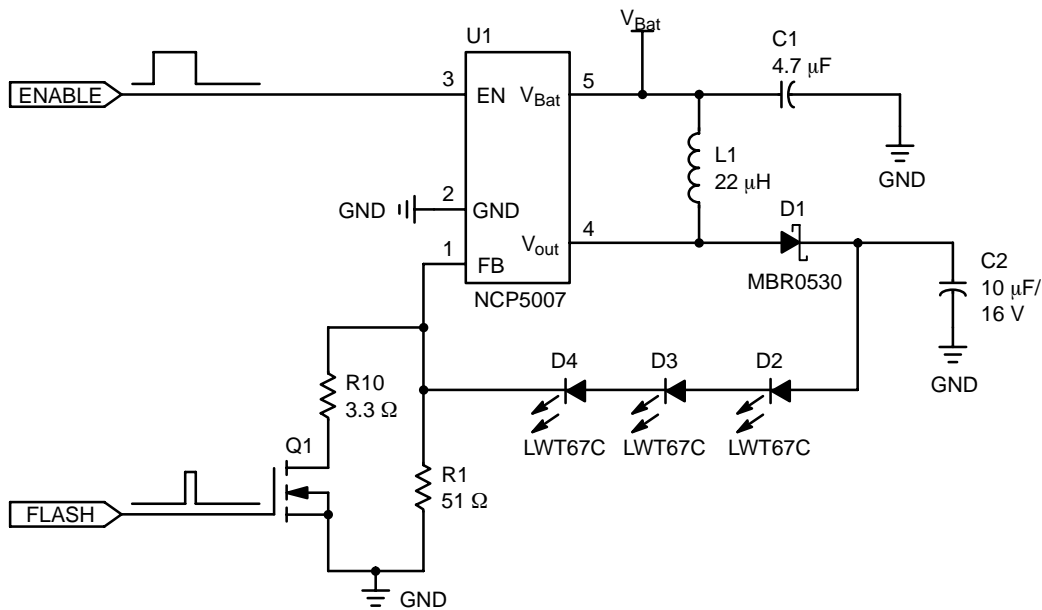

Figure 4. Typical Portable White LED Flash Circuit

**High Power Flash Mode**

Once the system is ready to take the photo, the flash is activated by forcing the high current bias into the white LEDs. Unlike the silver film, the electronic sensor of a digital camera cannot capture the scene in a couple of milliseconds, but a much longer delay is necessary to save all the pixels. Typically, such a delay ranges from 100 ms to 200 ms, depending upon the type of camera and lens. Consequently, using a reservoir capacitor to supply the large current during 200 ms is not really feasible. In fact, to sustain 100 mA during 200 ms, with three LEDs in series, assuming the voltage cannot drop more than 0.5 V during the pulse, one should have a 40000  $\mu$ F/16 V electrolytic capacitor, a value not compatible with a portable equipment. On top of that, to re-charge this capacitor in a reasonable time, typically one second, the DC/DC converter should provide around 500 mA when loading the capacitor from zero. Therefore, instead of designing a chip to re-charge a capacitor, it is far better to use the converter to supply immediately the current called by the application.

To activate the flash, one shall turn ON the NMOS Q1, providing a lower sense resistor in the feedback loop. The NMOS is selected with an internal R<sub>dson</sub> suitable for the expected current. Since the R<sub>dson</sub> of the NMOS varies largely with the temperature and the spread from one lot to another one is relatively large, one can get a more predictable circuit by using a larger NMOS associated with

an external resistor in series as depicted in the demo board schematic diagram. Table 1 gives a selection of the preferred product to handle such a function.

**Table 1. Preferred NMOS Products**

Part	I <sub>cmax</sub>	R <sub>dson</sub>	Package	BVSS
MMBF0201NLT1	6 A	35 m $\Omega$	SO-8	30 V
MMBF0201NLT1	0.2 A	1 $\Omega$	SOT-23	20 V
MMBF2201NT1	0.2 A	1 $\Omega$	SC-70	20 V
NTA4001NT1	0.24 A	1.5 $\Omega$	SC-75	20 V
MMFT960T1	0.3 A	1.7 $\Omega$	SOT-223	60 V

One can use a NPN bipolar device to fulfill this function, but the saturation voltages (V<sub>cesat</sub>) of such devices is close to the 200 mV define by the internal reference, and cannot be easily implemented in this type of circuit.

**DEMO BOARD SCHEMATIC DIAGRAM**

The demo board, depicted in Figure 10, supports the low beam and the high power flash, together with a digital PWM circuit to dim the LED. On top of that, a built-in clock provides the capability to generate multiple flash for evaluation purpose. The mode of operation is selected by means of switches S1 and S2, associated to potentiometers P1 to P4 as depicted Table 2.

The third switch S3 is a push button to manually trig the flash.

**Table 2. Switches Configurations and Potentiometers Functions**

S1	Select the NCP5007 mode of operation: GND = EN pin 3 forced to High, DC operation VCC = EN pin 3 pulsed	If S1 = VCC, then dim the light out of the LED : P1 = Adjust the pulse width applied to EN pin 3 P2 = Adjust the PWM frequency
S2	Select the Power Flash mode of operation: GND = Single shot triggered by S3 VCC = Repetitive mode	If S2 = VCC, then P3 = Adjust the power flash repetitive frequency P4 = Adjust the power flash duration
S3	Manual switch to trig the power flash	

The extra functions make possible the operation of the demo board on a stand alone basis, without any need from external control. However, in order to provide higher flexibility, provisions are made to connect the demo board to a MPU: the three pins connector shall be connected to the appropriate port to control the LED dimming and flash functions.

In the stand alone operation, switches S1 and S3 are forced to Low and the chip runs continuously. The low beam current is set up by the sense resistor R1: the demo board comes with a 51  $\Omega$  resistor, yielding 4 mA of DC current through the white LED. At this point, one can trig the flash by pushing switch S3. The flash is pre-set to provide 60 mA during the 200 ms time adjusted by potentiometer P4.

The system can be re-arranged to either dim the light when running the low beam current, or to generate a pulsed flash at a low pace.

The dimming function is activated when switch S1 is High. In this mode, the clock built with gates U3, associated with the one shot circuit U1, controls the EN pin 3, thus a PWM modulation of the DC load current.

The pulsed flash is activated when switch S2 is High. In this mode, the clock built with gates U3 and U4, associated with the second side of the one shot U1, provide a low rate to trig the flash. The pulse width can be manually adjusted with potentiometer P4.

The waveforms captured from the demo board (see Figure 5 to Figure 9), illustrate the currents and voltages across the major points.

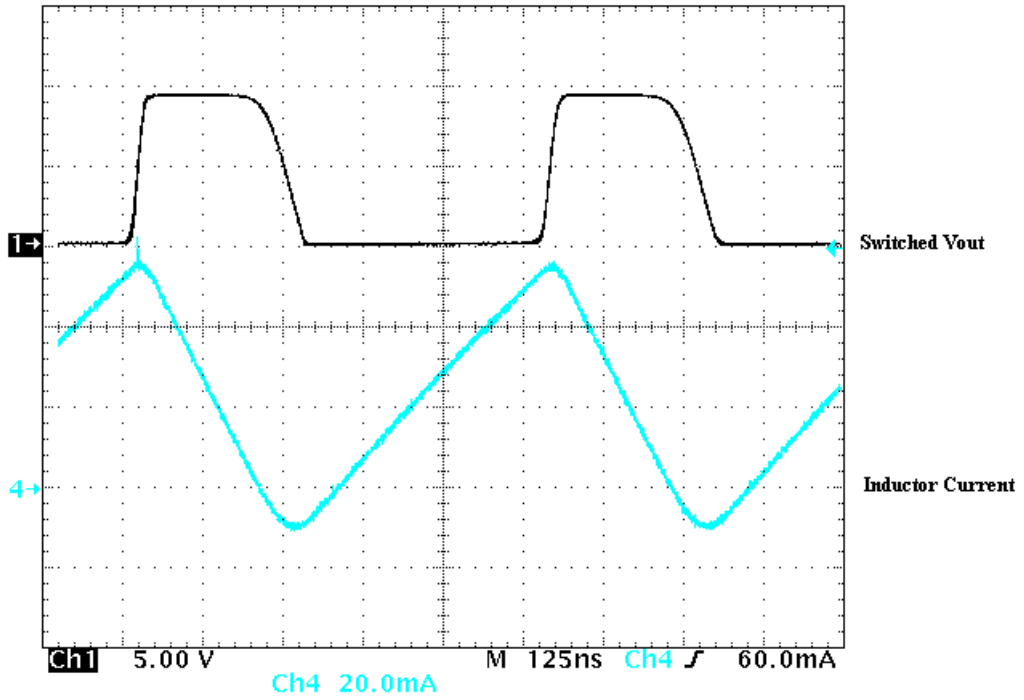

Figure 5. Low Beam Inductor Current

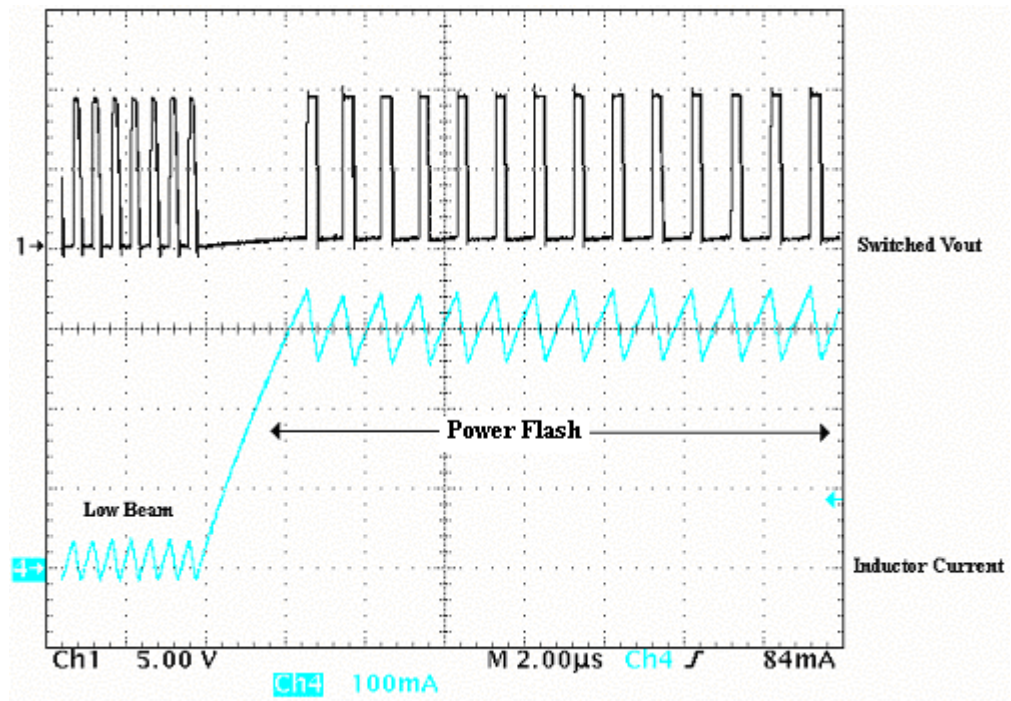

Figure 6. High Power Flash Inductor Current

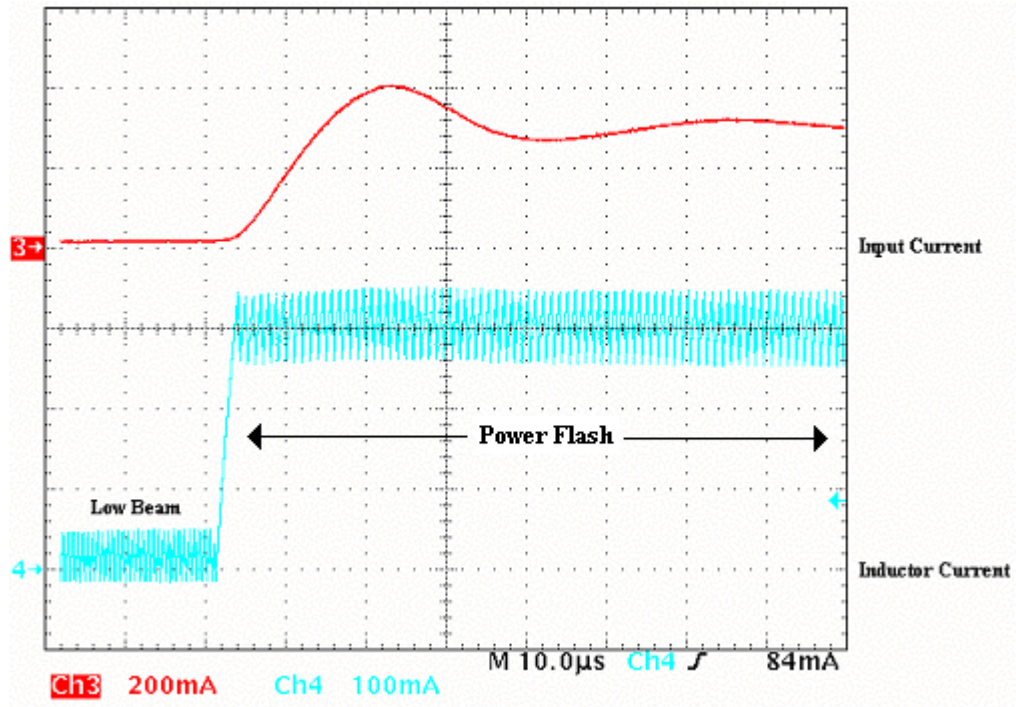

Figure 7. Input Supply Current

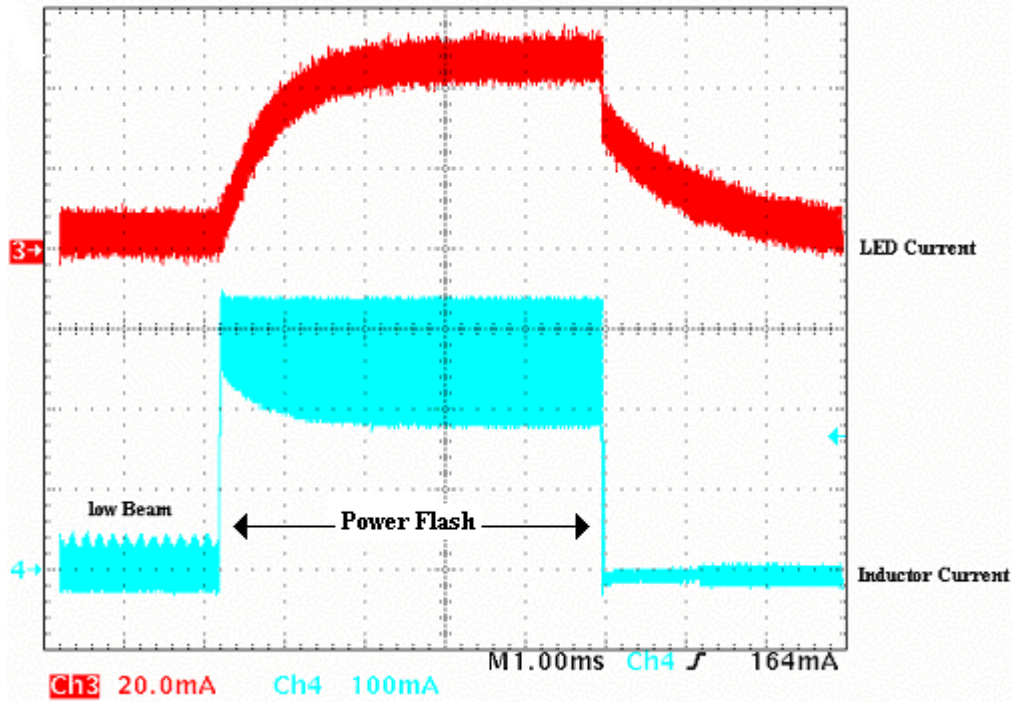

Figure 8. Low Beam & High Beam Output Current

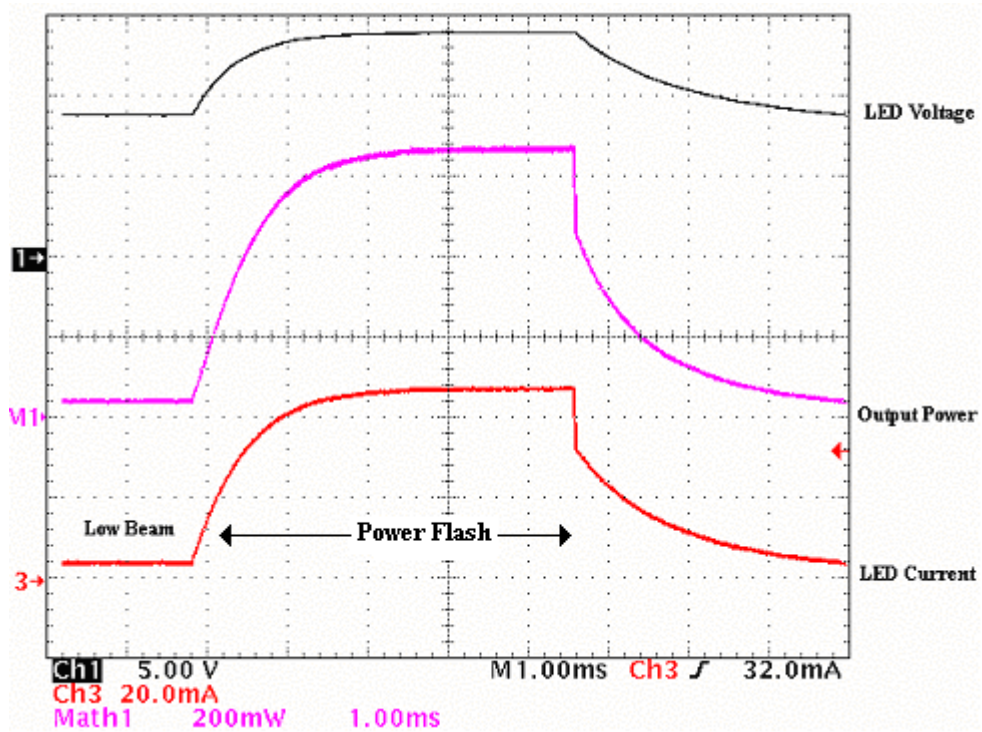

Figure 9. Combined Low Beam & Power Flash Output Current & Output Power

# AND8135/D

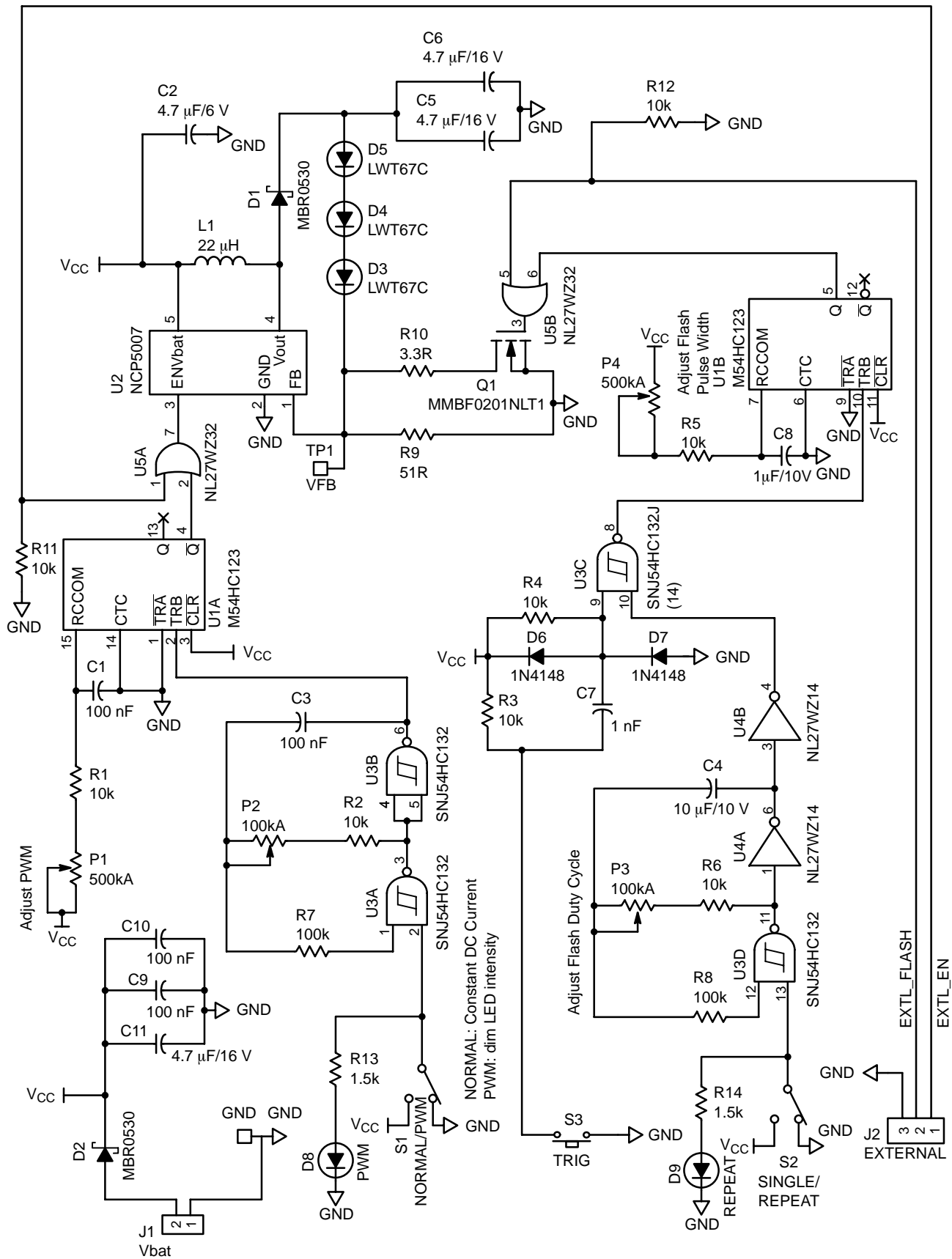

Figure 10. Demo Board Schematic Diagram

# AND8135/D

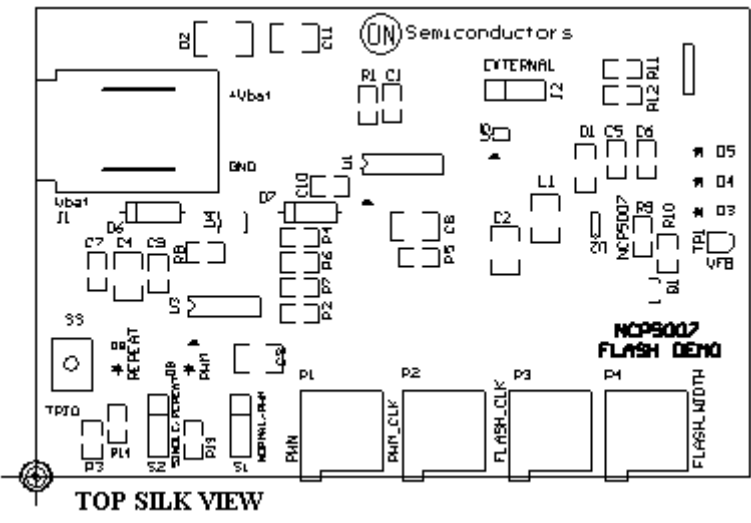
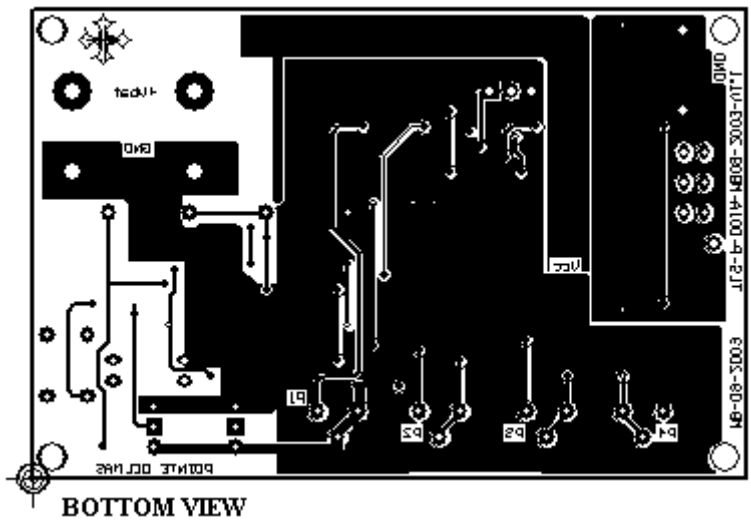
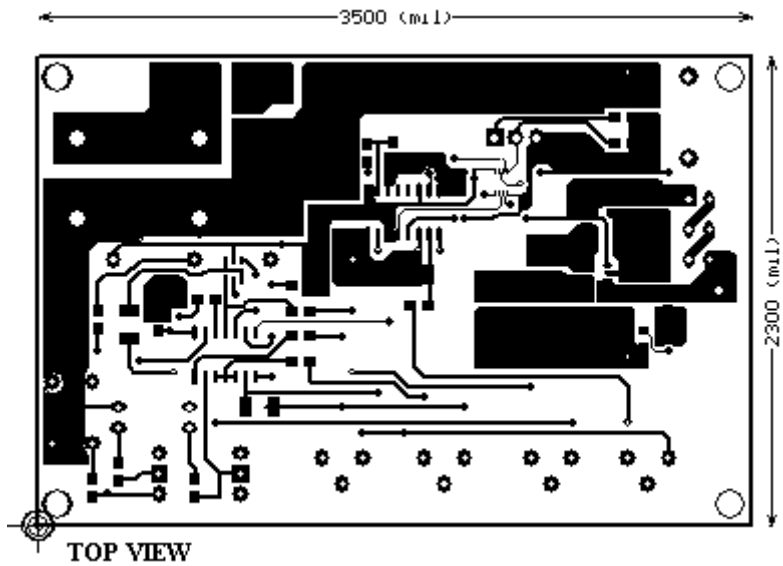



Figure 11. PCB Layout

## AND8135/D

**Table 3. High Beam Demo Board Part List**

Used	Part	Designator	Footprint	Description
2	1.5 kΩ	R13, R14	0805	Resistor
1	3.3 Ω	R10	0805	Resistor
1	51 Ω	R9	0805	Resistor
8	10 kΩ	R1, R2, R3, R4, R5, R6, R11, R12	0805	Resistor
2	100 kΩ	R7, R8	0805	Resistor
2	1N4148	D6, D7	DIODE0.4	Diode
2	100 kΩ	P2, P3	VR4	Potentiometer, Linear
1	500 kΩ	P1	VR4	Potentiometer, Linear
1	500 kΩ	P4	VR4	Potentiometer, Linear
4	100 nF	C1, C3, C9, C10	0805	Ceramic Capacitor, MURATA
1	10 μF/10 V	C4	1210	Ceramic Capacitor, MURATA
1	1 μF/10 V	C8	0805	Ceramic Capacitor, MURATA
1	1 nF	C7	0805	Ceramic Capacitor, MURATA
4	4.7 μF/6 V	C2, C5, C6, C11	1210	Ceramic Capacitor, MURATA
2	LED	D8, D9	LED_2	LED
3	LED	D3, D4, D5	LED_2	LED: OSRAM LWT67SQ2-4
1	22 μH	L1	1210	Inductor: CoilCraft 1008
1	M54HC123	U1	SO-16	Dual Retriggerable one shot
2	MBR0530	D1, D2	1210	Schottky Diode
1	SNJ54HC132	U3	SO-14	Quadruple Positive-NAND Gate with Schmitt-Trigger Input
1	MMBF0201NLT1	Q1	SOT-23	MOSFET
1	NCP5007	U2	TSSOP5	White LED driver
1	NL27WZ14	U4	SOT_23B	Dual schmitt trigger inverter
1	NL27WZ32	U5	US8	Dual OR gate
1	EXTERNAL	J2	SIP3	Connector
1	GND	Z1	GND_TEST	Connector
1	NORMAL/PWM	S1	SIP3	Manual Switch
1	SINGLE/REPEAT	S2	SIP3	Manual Switch
1	TRIG	S3	PUSH_BUT_B	Push Button
1	VFB	TP1	TEST_POINT	Connector
1	Vbat	J1	PLUG_4MM_DUAL	Connector

**ON Semiconductor** and  are registered trademarks of Semiconductor Components Industries, LLC (SCILLC). SCILLC reserves the right to make changes without further notice to any products herein. SCILLC makes no warranty, representation or guarantee regarding the suitability of its products for any particular purpose, nor does SCILLC assume any liability arising out of the application or use of any product or circuit, and specifically disclaims any and all liability, including without limitation special, consequential or incidental damages. "Typical" parameters which may be provided in SCILLC data sheets and/or specifications can and do vary in different applications and actual performance may vary over time. All operating parameters, including "Typicals" must be validated for each customer application by customer's technical experts. SCILLC does not convey any license under its patent rights nor the rights of others. SCILLC products are not designed, intended, or authorized for use as components in systems intended for surgical implant into the body, or other applications intended to support or sustain life, or for any other application in which the failure of the SCILLC product could create a situation where personal injury or death may occur. Should Buyer purchase or use SCILLC products for any such unintended or unauthorized application, Buyer shall indemnify and hold SCILLC and its officers, employees, subsidiaries, affiliates, and distributors harmless against all claims, costs, damages, and expenses, and reasonable attorney fees arising out of, directly or indirectly, any claim of personal injury or death associated with such unintended or unauthorized use, even if such claim alleges that SCILLC was negligent regarding the design or manufacture of the part. SCILLC is an Equal Opportunity/Affirmative Action Employer. This literature is subject to all applicable copyright laws and is not for resale in any manner.

## PUBLICATION ORDERING INFORMATION

### LITERATURE FULFILLMENT:

Literature Distribution Center for ON Semiconductor  
P.O. Box 5163, Denver, Colorado 80217 USA

**Phone:** 303-675-2175 or 800-344-3860 Toll Free USA/Canada

**Fax:** 303-675-2176 or 800-344-3867 Toll Free USA/Canada

**Email:** [orderlit@onsemi.com](mailto:orderlit@onsemi.com)

**N. American Technical Support:** 800-282-9855 Toll Free  
USA/Canada

**Japan:** ON Semiconductor, Japan Customer Focus Center  
2-9-1 Kamimeguro, Meguro-ku, Tokyo, Japan 153-0051  
**Phone:** 81-3-5773-3850

**ON Semiconductor Website:** <http://onsemi.com>

**Order Literature:** <http://www.onsemi.com/litorder>

For additional information, please contact your  
local Sales Representative.