

T-25-13

Sensitive Gate Triacs Silicon Bidirectional Thyristors

... designed primarily for full-wave ac control applications, such as light dimmers, motor controls, heating controls and power supplies; or wherever full-wave silicon gate controlled solid-state devices are needed. Triac type thyristors switch from a blocking to a conducting state for either polarity of applied anode voltage with positive or negative gate triggering.

- Sensitive Gate Triggering (A and B versions) Uniquely Compatible for Direct Coupling to TTL, HTL, CMOS and Operational Amplifier Integrated Circuit Logic Functions
- Gate Triggering 2 Mode — 2N6071 thru 2N6075
4 Mode — 2N6071A,B thru 2N6075A,B
- Blocking Voltages to 600 Volts
- All Diffused and Glass Passivated Junctions for Greater Parameter Uniformity and Stability
- Small, Rugged, Thermopad Construction for Low Thermal Resistance, High Heat Dissipation and Durability

**2N6071,A,B
thru
2N6075,A,B**

**TRIACs
4 AMPERES RMS
200 thru 600 VOLTS**

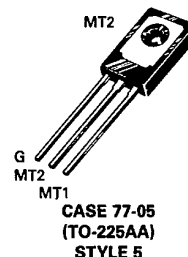

MAXIMUM RATINGS

Rating	Symbol	Value	Unit
*Repetitive Peak Off-State Voltage, Note 1 ($T_J = 110^\circ\text{C}$)	V_{DRM}	200 300 400 500 600	Volts
*On-State Current RMS ($T_C = 85^\circ\text{C}$)	$I_T(\text{RMS})$	4	Amps
*Peak Surge Current (One Full cycle, 60 Hz, $T_J = -40$ to $+110^\circ\text{C}$)	I_{TSM}	30	Amps
Circuit Fusing Considerations ($T_J = -40$ to $+110^\circ\text{C}$, $t = 1$ to 8.3 ms)	I^2t	3.6	A^2s
*Peak Gate Power	P_{GM}	10	Watts
*Average Gate Power	$P_{G(AV)}$	0.5	Watt
*Peak Gate Voltage	V_{GM}	5	Volts

*Indicates JEDEC Registered Data.

Note 1. Ratings apply for open gate conditions. Thyristor devices shall not be tested with a constant current source for blocking capability such that the voltage applied exceeds the rated blocking voltage.

MAXIMUM RATINGS

Rating	Symbol	Value	Unit
*Operating Junction Temperature Range	T _J	-40 to +110	°C
*Storage Temperature Range	T _{stg}	-40 to +150	°C
Mounting Torque (6-32 Screw), Note 1	—	8	in. lb.

*Indicates JEDEC Registered Data.

Note 1. Torque rating applies with use of compression washer (B52200F006). Mounting torque in excess of 6 in. lb. does not appreciably lower case-to-sink thermal resistance. Main terminal 2 and heatsink contact pad are common.

For soldering purposes (either terminal connection or device mounting), soldering temperatures shall not exceed +200°C, for 10 seconds. Consult factory for lead bending options.

THERMAL CHARACTERISTICS

Characteristic	Symbol	Max	Unit
*Thermal Resistance, Junction to Case	R _{θJC}	3.5	°C/W
Thermal Resistance, Case to Ambient	R _{θJA}	75	°C/W

*Indicates JEDEC Registered Data.

ELECTRICAL CHARACTERISTICS (T_C = 25°C unless otherwise noted.)

Characteristic	Symbol	Min	Typ	Max	Unit
*Peak Forward or Reverse Blocking Current (Rated V _{DRM} or V _{RRM} , gate open) T _J = 25°C T _J = 110°C	I _{DRM} , I _{RRM}	—	—	10 2	μA mA
*On-State Voltage (Either Direction) (I _{TM} = 6 A Peak)	V _{TM}	—	—	2	Volts
*Peak Gate Trigger Voltage (Continuous dc) (Main Terminal Voltage = 12 Vdc, R _L = 100 Ohms, T _J = -40°C) MT2(+), G(+); MT2(-), G(-) All Types MT2(+), G(-); MT2(-), G(+) (Main Terminal Voltage = Rated V _{DRM} , R _L = 10 k ohms, T _J = 110°C) MT2(+), G(+); MT2(-), G(-) All Types MT2(+), G(-); MT2(-), G(+) 2N6071A,B thru 2N6075A,B	V _{GT}	—	1.4 1.4	2.5 2.5	Volts
*Holding Current (Either Direction) (Main Terminal Voltage = 12 Vdc, Gate Open, T _J = -40°C) (Initiating Current = 1 Adc) 2N6071 thru 2N6075 2N6071A,B thru 2N6075A,B (T _J = 25°C) 2N6071 thru 2N6075 2N6071A,B thru 2N6075A,B	I _H	—	—	70 30 30 15	mA
Turn-On Time (Either Direction) (I _{TM} = 14 Adc, I _{GT} = 100 mAdc)	t _{on}	—	1.5	—	μs
Blocking Voltage Application Rate at Commutation @ V _{DRM} , T _J = 85°C, Gate Open	dv/dt	—	5	—	V/μs

*Indicates JEDEC Registered Data.

3

2N6071,A,B thru 2N6075,A,B

			QUADRANT (See Definition Below)					
			Type	I _{GT} @ T _J	I mA	II mA	III mA	IV mA
Gate Trigger Current (Continuous dc) (Main Terminal Voltage = 12 Vdc, R _L = 100 ohms)	Maximum Value		2N6071 thru 2N6075	+25°C	30	—	30	—
				-40°C	60	—	60	—
			2N6071A thru 2N6075A	+25°C	5	5	5	10
				-40°C	20	20	20	30
			2N6071B thru 2N6075B	+25°C	3	3	3	5
				-40°C	15	15	15	20

*Indicates JEDEC Registered Data.

**SAMPLE APPLICATION:
TTL-SENSITIVE GATE 4 AMPERE TRIAC
TRIGGERS IN MODES II AND III**

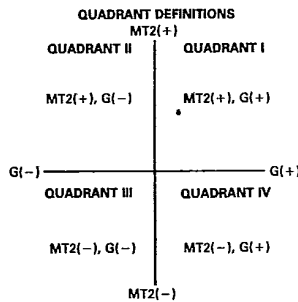
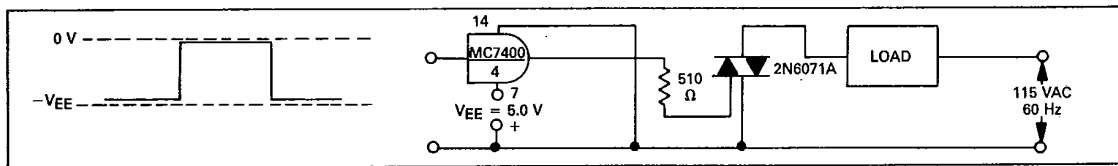

- Trigger devices are recommended for gating on Triacs. They provide:
1. Consistent predictable turn-on points.
 2. Simplified circuitry.
 3. Fast turn-on time for cooler, more efficient and reliable operation.

**For 2N6071 Thru 2N6075
ELECTRICAL CHARACTERISTICS of RECOMMENDED
BI-DIRECTIONAL SWITCHES**

Usage	General		Lamp Dimmer
Part Number	MBS4991	MBS4993	MBS100
V _S	6.0 - 10 V	7.5 - 9.0 V	3.0 - 5.0 V
I _S	350 μA Max	250 μA Max	100 - 400 μA
V _{S1} - V _{S2}	0.5 V Max	0.2 V Max	0.35 V Max
Temperature Coefficient	0.02%/°C Typ		

See AN-526 for Theory and Characteristics of Silicon Bidirectional Switches.

SENSITIVE GATE LOGIC REFERENCE

IC Logic Functions	Firing Quadrant			
	I	II	III	IV
TTL		2N6071A Series	2N6071A Series	
HTL		2N6071A Series	2N6071A Series	
CMOS (NAND)	2N6071B Series			2N6071B Series
CMOS (Buffer)		2N6071B Series	2N6071B Series	
Operational Amplifier	2N6071A Series			2N6071A Series
Zero Voltage Switch		2N6071A Series	2N6071A Series	



2N6071,A,B thru 2N6075,A,B

FIGURE 1 - AVERAGE CURRENT DERATING

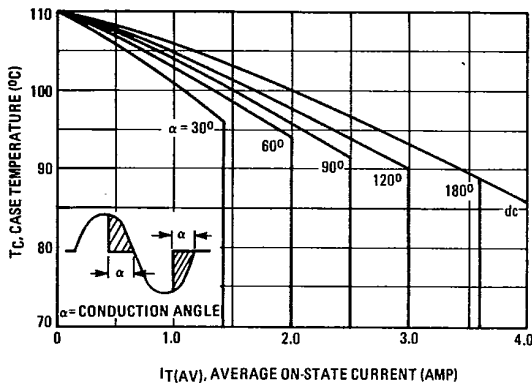

FIGURE 2 - RMS CURRENT DERATING

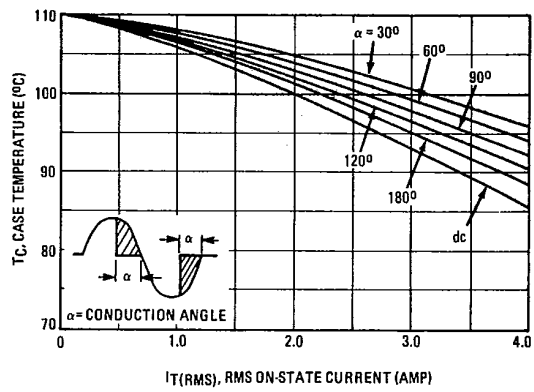

FIGURE 3 - POWER DISSIPATION

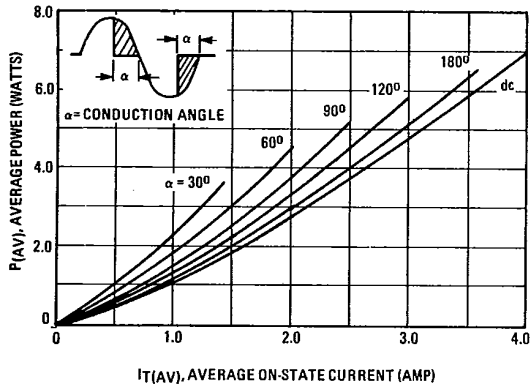
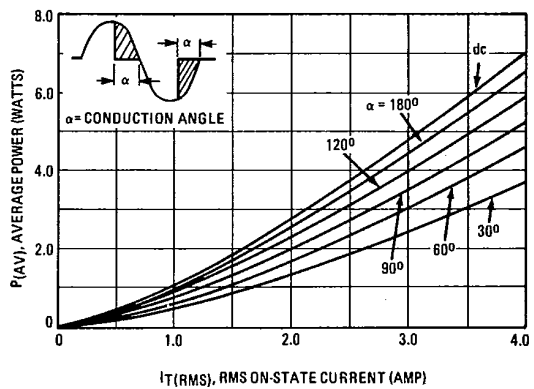

FIGURE 4 - POWER DISSIPATION



3

FIGURE 5 - TYPICAL GATE-TRIGGER VOLTAGE

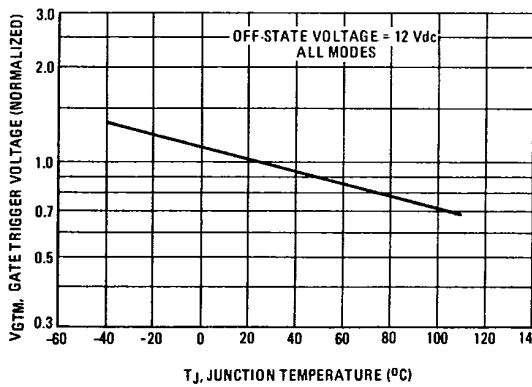
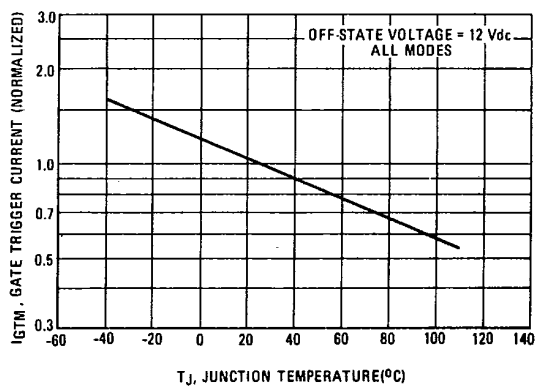

FIGURE 6 - TYPICAL GATE-TRIGGER CURRENT



2N6071,A,B thru 2N6075,A,B

FIGURE 7 - MAXIMUM ON-STATE CHARACTERISTICS

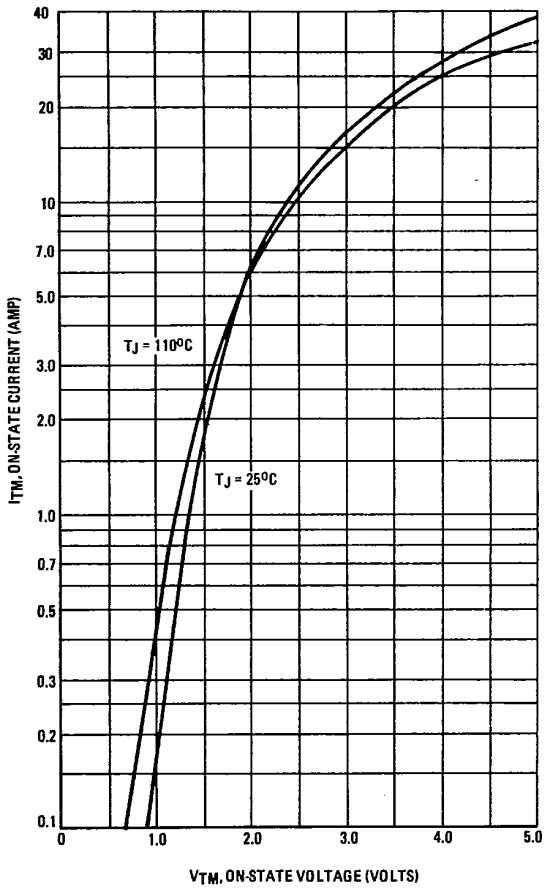

FIGURE 8 - TYPICAL HOLDING CURRENT

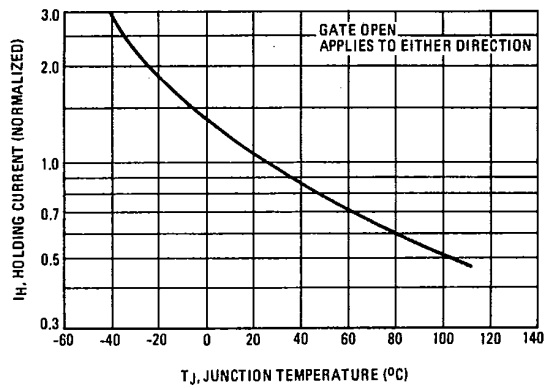

FIGURE 9 - MAXIMUM ALLOWABLE SURGE CURRENT

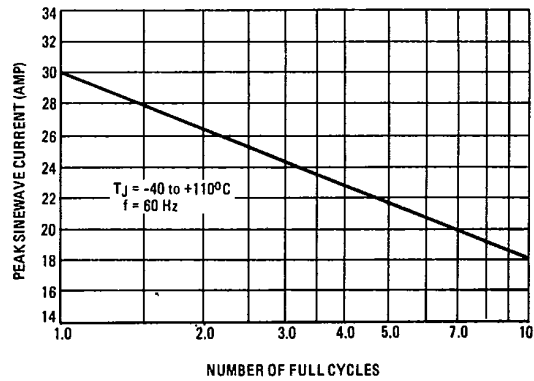

FIGURE 10 - THERMAL RESPONSE

