

6367254 MOTOROLA SC (XSTRS/R F)

96D 80660 D

**MOTOROLA SEMICONDUCTOR TECHNICAL DATA**

T-33-11

**BU204  
BU205**

**Designers Data Sheet**

**HORIZONTAL DEFLECTION TRANSISTOR**

... specifically designed for use in large screen color deflection circuits.

- Collector-Emitter Voltage -  $V_{CEX} = 1300 \text{ Vdc} - \text{BU204}$   
 $1500 \text{ Vdc} - \text{BU205}$
- Glassivated Base-Collector Junction
- Switching Times with Inductive Loads -  
 $t_f = 0.65 \mu\text{s} (\text{Typ}) @ I_C = 2\text{A}$

**2.5 AMPERE**

**NPN SILICON  
POWER TRANSISTORS**

**1300 AND 1500 VOLTS  
36 WATTS**

**Designer's Data for  
"Worst Case" Conditions**

The Designers' Data Sheet permits the design of most circuits entirely from the information presented. Limit data - representing device characteristics boundaries - are given to facilitate "worst case" design.

**MAXIMUM RATINGS**

| Rating   | Symbol         | BU204       | BU205 | Unit                      |
|--|----------------|-------------|-------|---------------------------|
| Collector-Emitter Voltage                          | $V_{CE0(sus)}$ | 600         | 700   | Vdc                       |
| Collector-Emitter Voltage                          | $V_{CEX}$      | 1300        | 1500  | Vdc                       |
| Emitter Base Voltage                               | $V_{EB}$       | 5.0         |       | Vdc                       |
| Collector Current - Continuous                     | $I_C$          | 2.5         |       | Adc                       |
| Collector Current - Peak (1)                       | $I_{CM}$       | 3           |       |                           |
| Base Current - Peak (1)                            | $I_{BM}$       | 2.5         |       | Adc                       |
| Total Power Dissipation @ $T_C = 25^\circ\text{C}$ | $P_D$          | 36          |       | Watts                     |
| Derate above $25^\circ\text{C}$                    |                | 10          |       |                           |
| Derate above $25^\circ\text{C}$                    |                | 0.4         |       | $\text{W}/^\circ\text{C}$ |
| Operating and Storage Junction Temperature Range   | $T_J, T_{stg}$ | -65 to +115 |       | $^\circ\text{C}$          |

**THERMAL CHARACTERISTICS**

| Characteristic                       | Symbol          | Max | Unit                      |
|--------------------------------------|-----------------|-----|---------------------------|
| Thermal Resistance, Junction to Case | $R_{\theta JC}$ | 2.5 | $^\circ\text{C}/\text{W}$ |

(1) Pulse Test: Pulse Width = 5 ms, Duty Cycle < 10%.

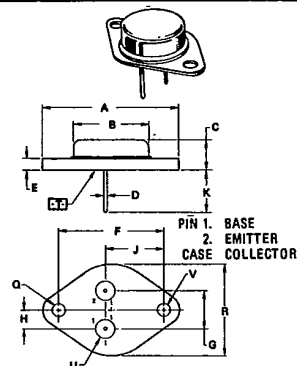

- NOTES:  
 1. DIMENSIONS Q AND V ARE DATUMS.  
 2. [E] IS SEATING PLANE AND DATUM.  
 3. POSITIONAL TOLERANCE FOR MOUNTING HOLE Q:

$$\pm 0.13 (0.005) \text{ T } \text{V} \text{O}$$

FOR LEADS:

$$\pm 0.13 (0.005) \text{ T } \text{V} \text{O} \text{ D} \text{O}$$

4. DIMENSIONS AND TOLERANCES PER ANSI Y14.5, 1973.

| DIM | MILLIMETERS |       | INCHES    |       |
|-----|-------------|-------|-----------|-------|
|     | MIN         | MAX   | MIN       | MAX   |
| A   | -           | 39.37 | -         | 1.550 |
| B   | -           | 21.08 | -         | 0.830 |
| C   | 5.35        | 7.62  | 0.210     | 0.300 |
| D   | 0.97        | 1.09  | 0.038     | 0.043 |
| E   | 1.40        | 1.28  | 0.055     | 0.070 |
| F   | 30.15 BSC   |       | 1.187 BSC |       |
| G   | 10.92 BSC   |       | 0.430 BSC |       |
| H   | 3.45 BSC    |       | 0.215 BSC |       |
| J   | 16.80 BSC   |       | 0.664 BSC |       |
| K   | 11.18       | 12.19 | 0.440     | 0.480 |
| Q   | 3.81        | 4.19  | 0.150     | 0.165 |
| R   | -           | 28.57 | -         | 1.125 |
| U   | 4.83        | 5.33  | 0.190     | 0.210 |
| V   | 3.81        | 4.19  | 0.150     | 0.165 |

CASE 1-06

3

6367254 MOTOROLA SC (XSTRS/R F)  
 BU204, BU205

96D 80661 D  
 T-33-11

**ELECTRICAL CHARACTERISTICS** ( $T_C = 25^\circ$  unless otherwise noted.)

| Characteristic   | Symbol         | Min           | Typ           | Max        | Unit    |
|--|----------------|---------------|---------------|------------|---------|
| <b>OFF CHARACTERISTICS (1)</b>   |                |               |               |            |         |
| Collector-Emitter Sustaining Voltage<br>( $I_C = 100$ mA, $I_B = 0$ )                                      | BU204<br>BU205 | $V_{CE(sus)}$ | 600<br>700    | —          | Vdc     |
| Collector Cutoff Current<br>( $V_{CE} = 1300$ Vdc, $V_{BE} = 0$ )<br>( $V_{CE} = 1500$ Vdc, $V_{BE} = 0$ ) | BU204<br>BU205 | $I_{CES}$     | —             | 1.0<br>1.0 | mA      |
| Emitter Base Voltage<br>( $I_E = 10$ mA, $I_C = 0$ )   |                | $V_{EBO}$     | 5.0           | —          | Vdc     |
| <b>ON CHARACTERISTICS (1)</b>  |                |               |               |            |         |
| Collector-Emitter Saturation Voltage<br>( $I_C = 2.0$ A, $I_B = 1.0$ A)                                    |                | $V_{CE(sat)}$ | —             | 5.0        | Vdc     |
| Base Emitter Saturation Voltage<br>( $I_C = 2.0$ A, $I_B = 1.0$ A)   |                | $V_{BE(sat)}$ | —             | 1.5        | Vdc     |
| Second Breakdown Collector Current with Base Forward Biased  |                | $I_{S/B}$     | See Figure 14 |            |         |
| <b>DYNAMIC CHARACTERISTICS</b>   |                |               |               |            |         |
| Current-Gain - Bandwidth Product (1)<br>( $I_C = 0.1$ A, $V_{CE} = 5.0$ Vdc, $f_{test} = 1.0$ MHz)         |                | $f_T$         | —             | 4.0        | MHz     |
| Output Capacitance<br>( $V_{CB} = 10$ Vdc, $I_E = 0$ , $f = 1.0$ MHz)                                      |                | $C_{ob}$      | —             | 50         | pF      |
| <b>SWITCHING CHARACTERISTICS</b>   |                |               |               |            |         |
| Fall Time<br>( $I_C = 2.0$ A, $I_{B1} = 1.0$ A, $L_B = 25$ $\mu$ H) (See Figure 1)                         |                | $t_f$         | —             | 0.65       | $\mu$ s |

(1) Pulse Test: Pulse Width < 300  $\mu$ s, Duty Cycle = 2%.

FIGURE 1 - TEST CIRCUIT

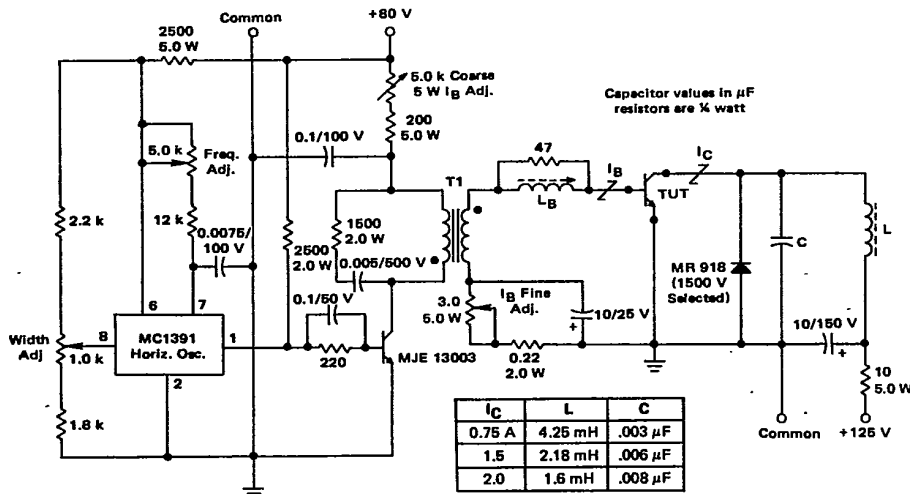

**DRIVER TRANSFORMER (T1)**

Motorola part number 25D68782A-05-1/4" laminate "E" iron core. Primary Inductance - 39 mH, Secondary Inductance - 22 mH, Leakage Inductance with primary shorted - 2.0  $\mu$ H, Primary 260 turns #28 AWG enamel wire, Secondary 17 turns, #22 AWG enamel wire.



**BASE DRIVE: The Key to Performance**

By now, the concept of controlling the shape of the turn-off base current is widely accepted and applied in horizontal deflection design. The problem stems from the fact that good saturation of the output device, prior to turn-off, must be assured. This is accomplished by providing more than enough  $I_{B1}$  to satisfy the lowest gain output device  $h_{FE}$  at the end of scan  $I_{CM}$ . Worst case component variations and maximum high voltage loading must also be taken into account.

If the base of the output transistor is driven by a very low impedance source, the turn-off base current will reverse very quickly as shown in Figure 2. This results in rapid, but only partial, collector turn-off, because excess carriers become trapped in the high resistivity collector and the transistor is still conductive. This is a high dissipation mode, since the collector voltage is rising very rapidly. The problem is overcome by adding inductance to the base circuit to slow the base current reversal as shown in Figure 3, thus allowing excess carrier recombination in the collector to occur while the base current is still flowing.

Choosing the right  $L_B$  is usually done empirically, since the equivalent circuit is complex, and since there are several important variables ( $I_{CM}$ ,  $I_{B1}$ , and  $h_{FE}$  at  $I_{CM}$ ). One method is to plot fall time as a function of  $L_B$  at the desired conditions, for several devices within the  $h_{FE}$  specification. A more informative method is to plot power dissipation versus  $I_{B1}$  for a range of values of  $L_B$  as shown

in Figures 4 and 5. This shows the parameter that really matters, dissipation, whether caused by switching or by saturation. The negative slope of these curves at the left (low  $I_{B1}$ ) is caused by saturation losses. The positive slope portion at higher  $I_{B1}$ , and low values of  $L_B$  is due to switching losses as described above. Note that for very low  $L_B$  a very narrow optimum is obtained. This occurs when  $I_{B1} h_{FE} = I_{CM}$ , and therefore would be acceptable only for the "typical" device with constant  $I_{CM}$ . As  $L_B$  is increased, the curves become broader and flatter above the  $I_{B1} h_{FE} = I_{CM}$  point as the turn-off "tails" are brought under control. Eventually, if  $L_B$  is raised too far, the dissipation all across the curve will rise, due to poor initiation of switching rather than tailing. Plotting this type of curve family for devices of different  $h_{FE}$ , essentially moves the curves to the left or right according to the relation  $I_{B1} h_{FE} = \text{constant}$ . It then becomes obvious that, for a specified  $I_{CM}$ , an  $L_B$  can be chosen which will give low dissipation over a range of  $h_{FE}$  and/or  $I_{B1}$ . The only remaining decision is to pick  $I_{B1}$  high enough to accommodate the lowest  $h_{FE}$  part specified. Figure 8 gives values recommended for  $L_B$  and  $I_{B1}$  for this device over a wide range of  $I_{CM}$ . These values were chosen from a large number of curves like Figure 4 and Figure 5. Neither  $L_B$  nor  $I_{B1}$  are absolutely critical, as can be seen from the examples shown, and values of Figure 8 are provided for guidance only.

**TEST CIRCUIT WAVEFORMS**

FIGURE 2

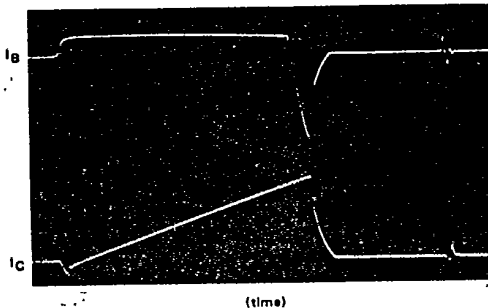
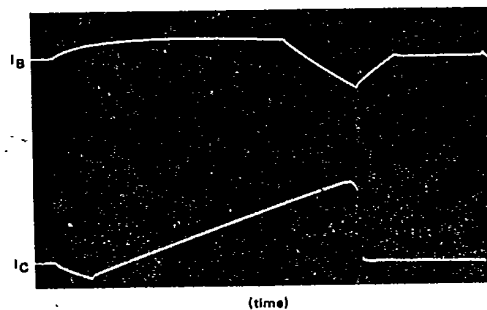

FIGURE 3



**TEST CIRCUIT OPTIMIZATION**

The test circuit may be used to evaluate devices in the conventional manner, i.e., to measure fall time, storage time, and saturation voltage. However, this circuit was designed to evaluate devices by a simple criterion, power supply input. Excessive power input can be caused by a variety of problems, but it is the dissipation in the transistor that is of fundamental importance.

Once the required transistor operating current is determined, fixed circuit values may be selected from the table. Factory testing is performed by reading the current meter only, since the input power is proportional to current. No adjustment of the test apparatus is required.

3

6367254 MOTOROLA SC (XSTRS/R F)  
 BU204, BU205

96D 80663 D

T-33-11

FIGURE 4 - OPTIMIZING DRIVE @  $I_C = 0.75$  A

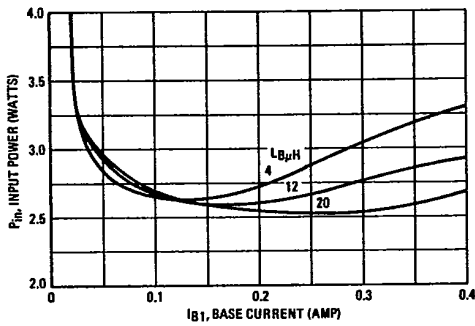

FIGURE 5 - OPTIMIZING DRIVE @  $I_C = 1.5$  A

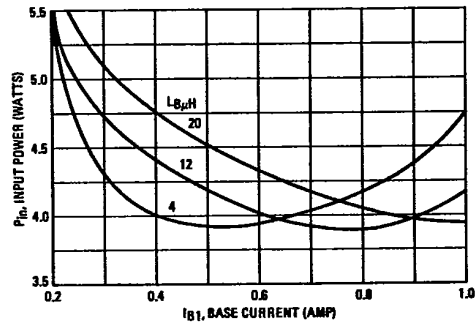

FIGURE 6 - OPTIMIZING DRIVE @  $I_C = 2.0$  A

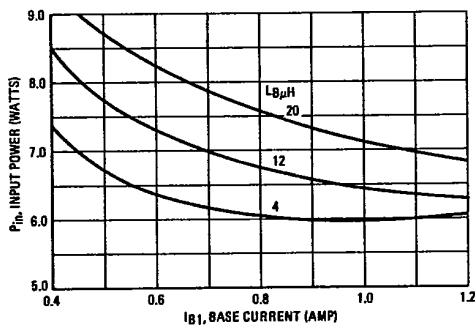

FIGURE 7 - SWITCHING BEHAVIOR versus TEMPERATURE

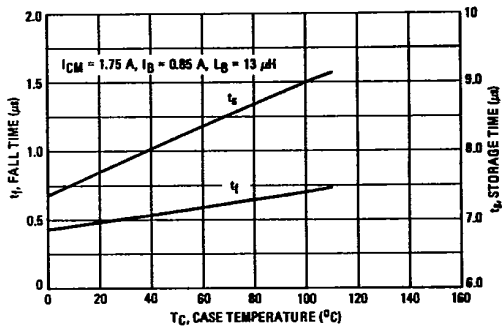

FIGURE 8 - OPTIMUM DRIVE CONDITIONS

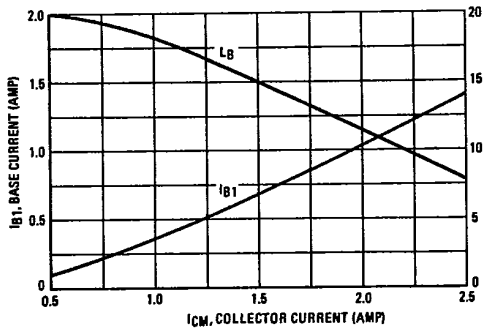

FIGURE 9 - SWITCHING BEHAVIOR versus  $I_{CM}$

