

LM337M

Three-Terminal Adjustable Output Negative Voltage Regulator

The LM337M is an adjustable three-terminal negative voltage regulator capable of supplying in excess of 500 mA over an output voltage range of -1.2 V to -37 V . This voltage regulator is exceptionally easy to use and requires only two external resistors to set the output voltage. Further, it employs internal current limiting, thermal shutdown and safe area compensation, making it essentially blow-out proof.

The LM337M serves a wide variety of applications including local, on-card regulation. This device can also be used to make a programmable output regulator or by connecting a fixed resistor between the adjustment and output. The LM337M can be used as a precision current regulator.

- Output Current in Excess of 500 mA
- Output Adjustable Between -1.2 V and -37 V
- Internal Thermal Overload Protection
- Internal Short Circuit Current Limiting
- Output Transistor Safe-Area Compensation
- Floating Operation for High Voltage Applications
- Standard 3-Lead Transistor Packages
- Eliminates Stocking Many Fixed Voltages

MEDIUM CURRENT THREE-TERMINAL ADJUSTABLE NEGATIVE VOLTAGE REGULATOR SEMICONDUCTOR TECHNICAL DATA

T SUFFIX
PLASTIC PACKAGE
CASE 221A

- Pin 1. Adjust
2. V_{in}
3. V_{out}

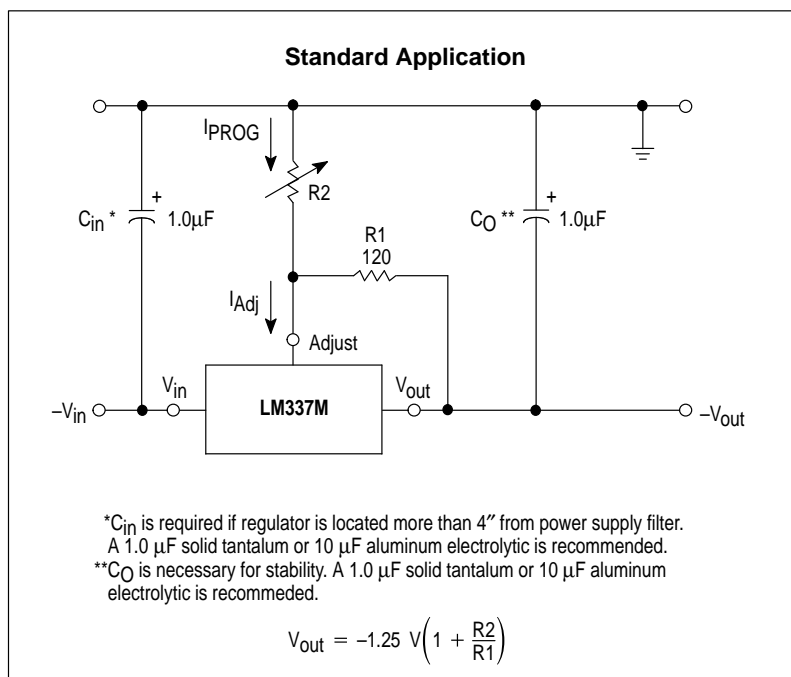
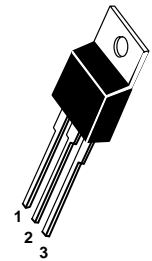

ORDERING INFORMATION

Device	Operating Temperature Range	Package
LM337MT	$T_J = 0^\circ$ to $+125^\circ\text{C}$	Plastic Power

LM337M

MAXIMUM RATINGS

Rating	Symbol	Value	Unit
Input–Output Voltage Differential	$V_I - V_O$	40	Vdc
Power Dissipation	P_D	Internally Limited	W
Operating Junction Temperature Range	T_J	0 to +125	°C
Storage Temperature Range	T_{stg}	–65 to +150	°C

ELECTRICAL CHARACTERISTICS ($|V_I - V_O| = 5.0$ V, $I_O = 0.1$; $T_J = T_{low}$ to T_{high} [Note 1], P_{max} per Note 2, unless otherwise noted.)

Characteristics	Figure	Symbol	Min	Typ	Max	Unit
Line Regulation (Note 3) $T_A = 25^\circ\text{C}$, $3.0\text{ V} \leq V_I - V_O \leq 40\text{ V}$	1	Reg _{line}	–	0.01	0.04	%/V
Load Regulation (Note 3) $T_A = 25^\circ\text{C}$, $10\text{ mA} \leq I_O \leq 0.5\text{ A}$ $ V_O \leq 5.0\text{ V}$ $ V_O \geq 5.0\text{ V}$	2	Reg _{load}	– –	15 0.3	15 1.0	mV %/V _O
Thermal Regulation 10 ms Pulse, $T_A = 25^\circ\text{C}$	–	Reg _{therm}	–	0.03	0.04	% V _O /W
Adjustment Pin Current	3	I_{Adj}	–	65	100	μA
Adjustment Pin Current Change $2.5\text{ V} \leq V_I - V_O \leq 40\text{ V}$, $10\text{ mA} \leq I_L \leq 0.5\text{ A}$, $P_D \leq P_{max}$, $T_A = 25^\circ\text{C}$	1, 2	ΔI_{Adj}	–	2.0	5.0	μA
Reference Voltage $3.0\text{ V} \leq V_I - V_O \leq 40\text{ V}$, $10\text{ mA} \leq I_O \leq 0.5\text{ A}$, $P_D \leq P_{max}$, $T_A = 25^\circ\text{C}$ T_{low} to T_{high}	3	V_{ref}	–1.213 –1.20	–1.250 –1.25	–1.287 –1.30	V
Line Regulation (Note 3) $3.0\text{ V} \leq V_I - V_O \leq 40\text{ V}$	1	Reg _{line}	–	0.02	0.07	%/V
Load Regulation (Note 3) $10\text{ mA} \leq I_O \leq 0.5\text{ A}$ $ V_O \leq 5.0\text{ V}$ $ V_O \geq 5.0\text{ V}$	2	Reg _{load}	– –	20 0.3	70 1.5	mV %/V _O
Temperature Stability ($T_{low} \leq T_J \leq T_{high}$)	3	T_S	–	0.6	–	%/V _O
Minimum Load Current to Maintain Regulation ($ V_I - V_O \leq 10\text{ V}$) ($ V_I - V_O \leq 40\text{ V}$)	3	I_{Lmin}	– –	1.5 2.5	6.0 10	mA
Maximum Output Current $ V_I - V_O \leq 15\text{ V}$, $P_D \leq P_{max}$ $ V_I - V_O \leq 40\text{ V}$, $P_D \leq P_{max}$, $T_J = 25^\circ\text{C}$	3	I_{max}	0.5 0.1	0.9 0.25	– –	A
RMS Noise, % of V _O $T_A = 25^\circ\text{C}$, $10\text{ Hz} \leq f \leq 10\text{ kHz}$	–	N	–	0.003	–	%/V _O
Ripple Rejection, V _O = –10 V, f = 120 Hz (Note 4) Without C _{Adj} C _{Adj} = 10 μF	4	RR	– 66	60 77	– –	dB
Long Term Stability, $T_J = T_{high}$ (Note 5) $T_A = 25^\circ\text{C}$ for Endpoint Measurements	3	S	–	0.3	1.0	%/1.0 k Hrs
Thermal Resistance, Junction–to–Case	–	R _{θJC}	–	7.0	–	°C/W

NOTES: 1. T_{low} to $T_{high} = 0^\circ$ to $+125^\circ\text{C}$

2. $P_{max} = 7.5\text{ W}$

3. Load and line regulation are specified at constant junction temperature. Changes in V_O due to heating effects must be taken into account separately. Pulse testing with low duty cycle is used.

4. C_{Adj}, when used, is connected between the adjustment pin and ground.

5. Since Long Term Stability cannot be measured on each device before shipment, this specification is an engineering estimate of average stability from lot to lot.

LM337M

Schematic Diagram

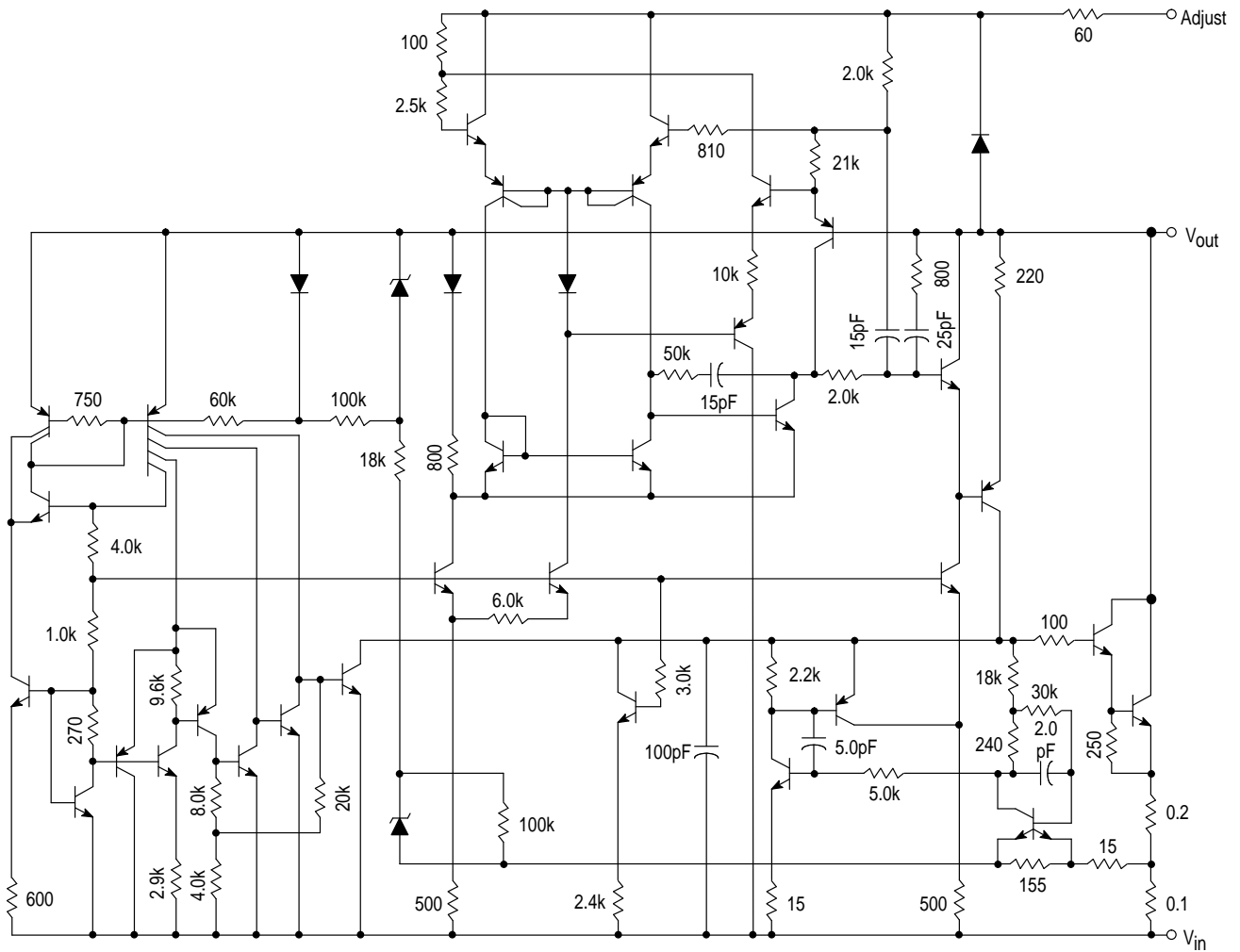
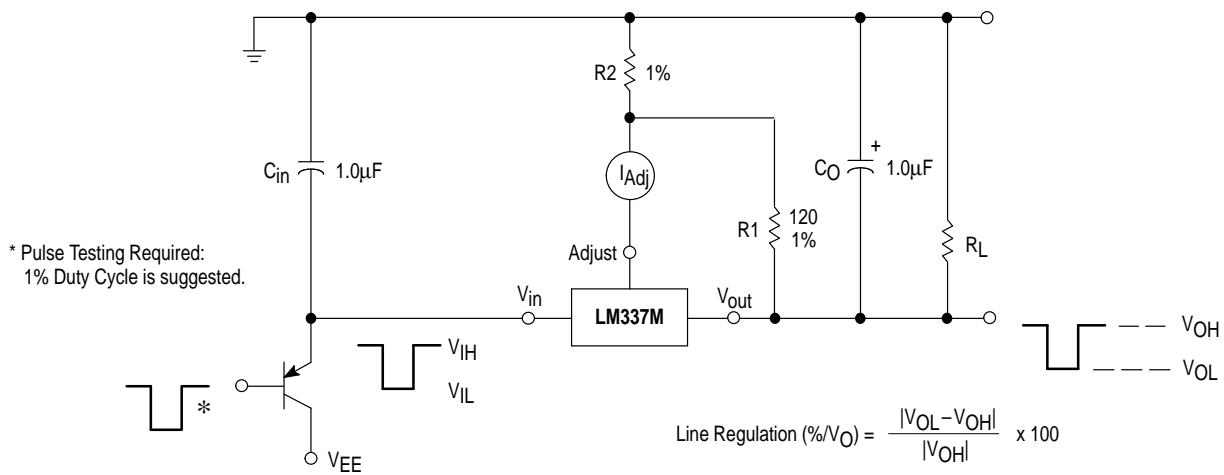

Figure 1. Line Regulation and $\Delta I_{Adj}/Line$ Test Circuit



LM337M

Figure 2. Load Regulation and ΔI_{Adj} /Load Test Circuit

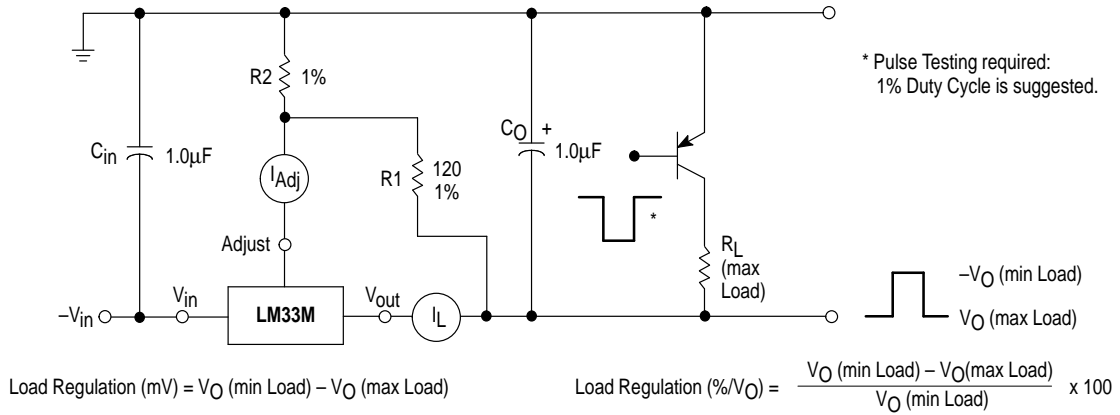

Figure 3. Standard Test Circuit

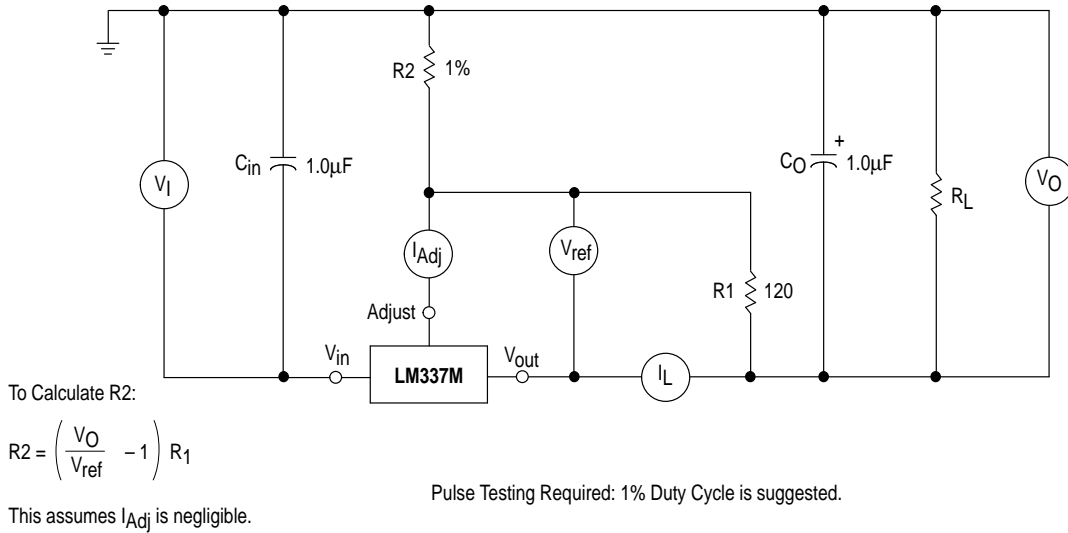

Figure 4. Ripple Rejection Test Circuit

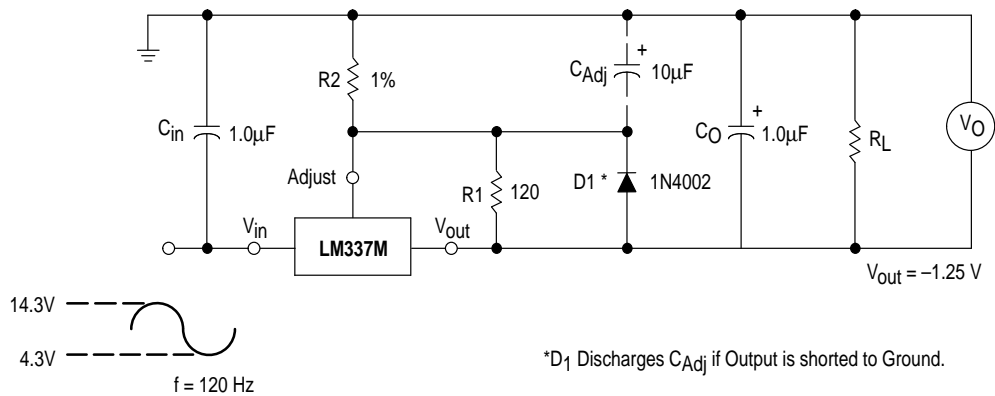

Figure 5. Load Regulation

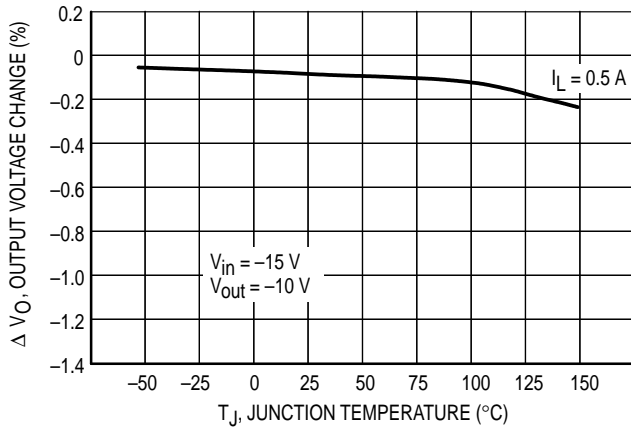

Figure 6. Current Limit

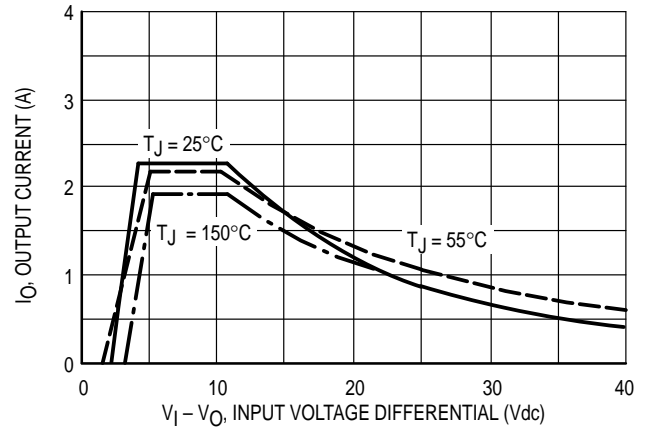

Figure 7. Adjustment Pin Current

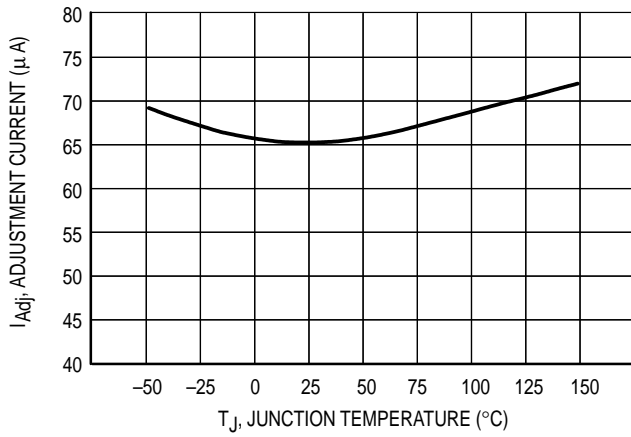

Figure 8. Dropout Voltage

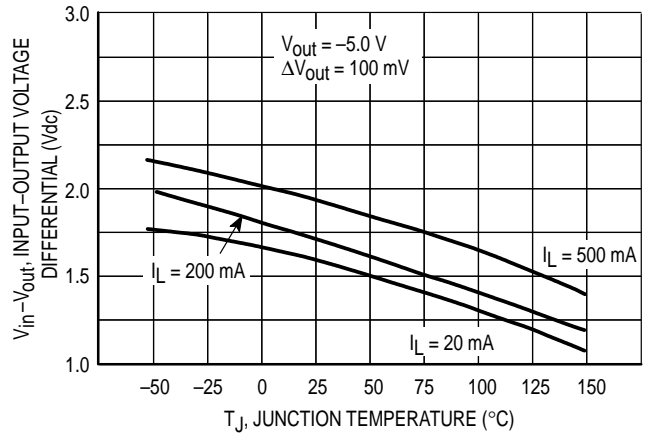

Figure 9. Temperature Stability

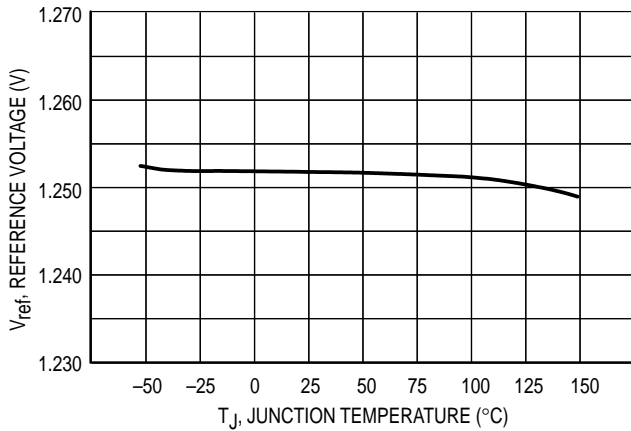

Figure 10. Minimum Operating Current

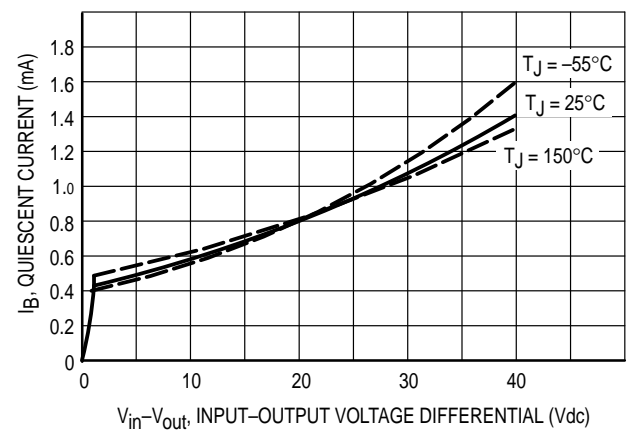

Figure 11. Ripple Rejection versus Output Voltage

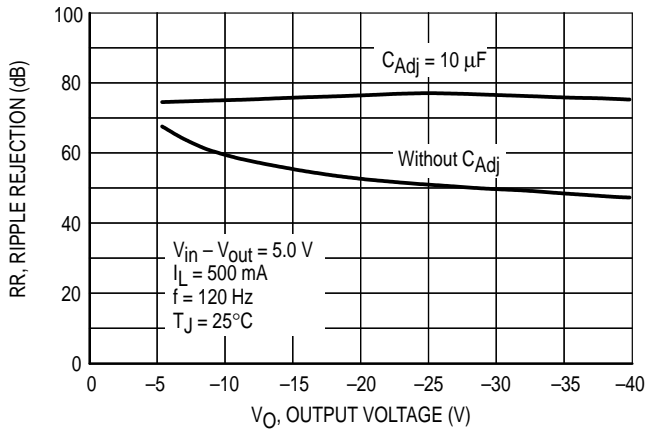

Figure 12. Ripple Rejection versus Output Current

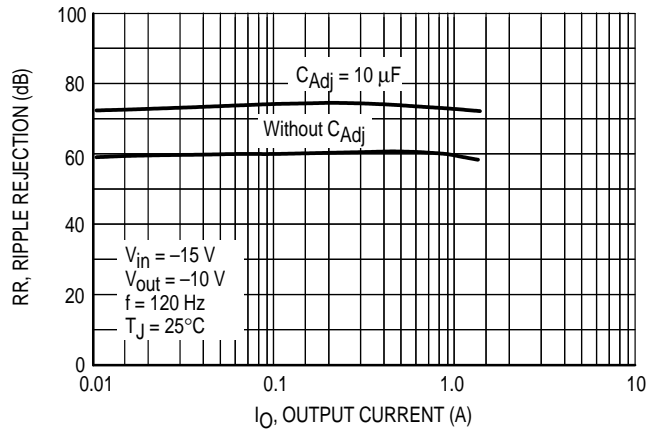

Figure 13. Ripple Rejection versus Frequency

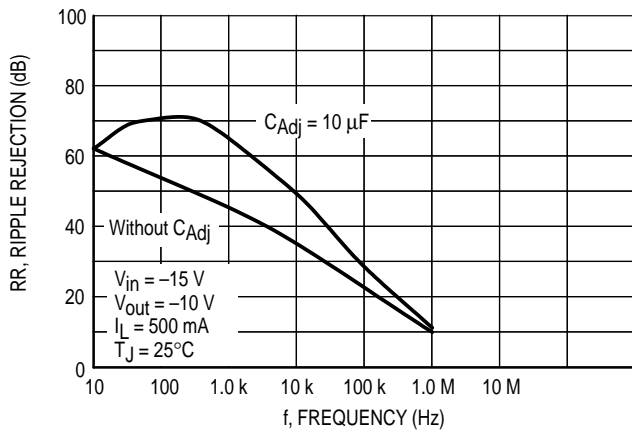

Figure 14. Output Impedance

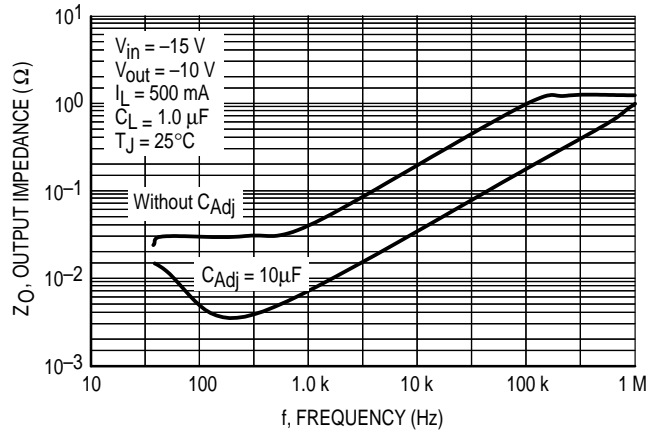

Figure 15. Line Transient Response

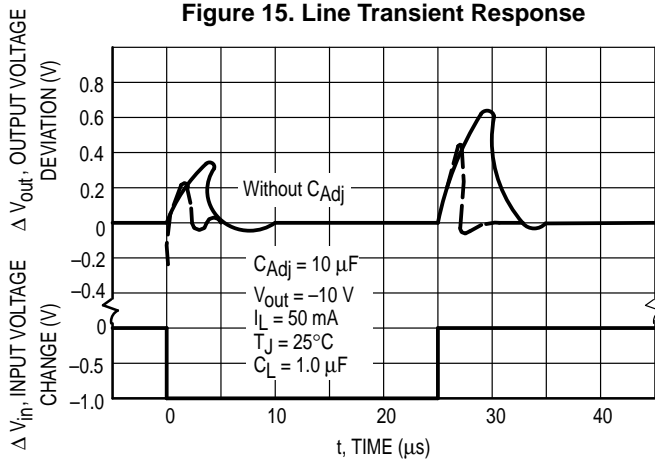
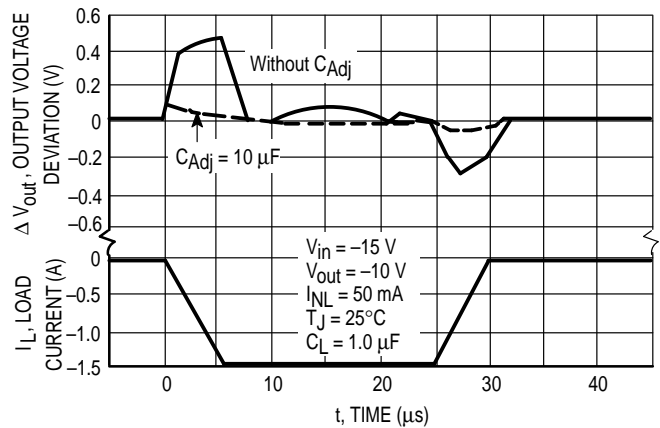

Figure 16. Load Transient Response



LM337M

APPLICATIONS INFORMATION

Basic Circuit Operation

The LM337M is a three-terminal floating regulator. In operation, the LM337M develops and maintains a nominal -1.25 V reference (V_{ref}) between its output and adjustment terminals. This reference voltage is converted to a programming current (I_{PROG}) by R_1 (see Figure 17), and this constant current flows through R_2 to ground. The regulated output voltage is given by:

$$V_{\text{out}} = V_{\text{ref}} \left(1 + \frac{R_2}{R_1}\right) + I_{\text{Adj}} R_2$$

Since the current into the adjustment terminal (I_{Adj}) represents an error term in the equation, the LM337M was designed to control I_{Adj} to less than $100\ \mu\text{A}$ and keep it constant. To do this, all quiescent operating current is returned to the output terminal. This imposes the requirement for a minimum load current. If the load current is less than this minimum, the output voltage will rise.

Since the LM337M is a floating regulator, it is only the voltage differential across the circuit which is important to performance, and operation at high voltages with respect to ground is possible.

Figure 17. Basic Circuit Configuration

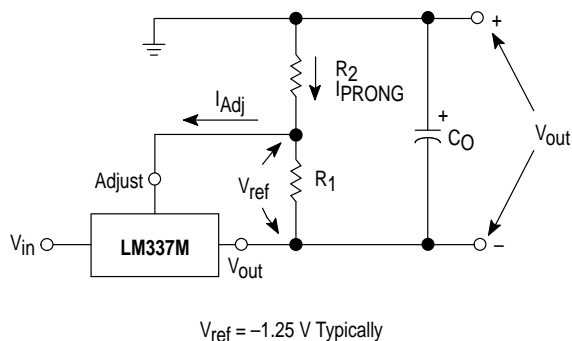

Load Regulation

The LM337M is capable of providing extremely good load regulation, but a few precautions are needed to obtain maximum performance. For best performance, the programming resistor (R_1) should be connected as close to the regulator as possible to minimize line drops which effectively appear in series with the reference, thereby

degrading regulation. The ground end of R_2 can be returned near the load ground to provide remote ground sensing and improve load regulation.

External Capacitors

A $1.0\ \mu\text{F}$ tantalum input bypass capacitor (C_{in}) is recommended to reduce the sensitivity to input line impedance.

The adjustment terminal may be bypassed to ground to improve ripple rejection. This capacitor (C_{Adj}) prevents ripple from being amplified as the output voltage is increased. A $10\ \mu\text{F}$ capacitor should improve ripple rejection about $15\ \text{dB}$ at $120\ \text{Hz}$ in a $10\ \text{V}$ application.

An output capacitance (C_{O}) in the form of a $1.0\ \mu\text{F}$ tantalum or $10\ \mu\text{F}$ aluminum electrolytic capacitor is required for stability.

Protection Diodes

When external capacitors are used with any IC regulator it is sometimes necessary to add protection diodes to prevent the capacitors from discharging through low current points into the regulator.

Figure 18 shows the LM337M with the recommended protection diodes for output voltages in excess of $-25\ \text{V}$ or high capacitance values ($C_{\text{O}} > 25\ \mu\text{F}$, $C_{\text{Adj}} > 10\ \mu\text{F}$). Diode D_1 prevents C_{O} from discharging thru the IC during an input short circuit. Diode D_2 protects against capacitor C_{Adj} discharging through the IC during an output short circuit. The combination of diodes D_1 and D_2 prevents C_{Adj} from discharging through the IC during an input short circuit.

Figure 18. Voltage Regulator with Protection Diodes

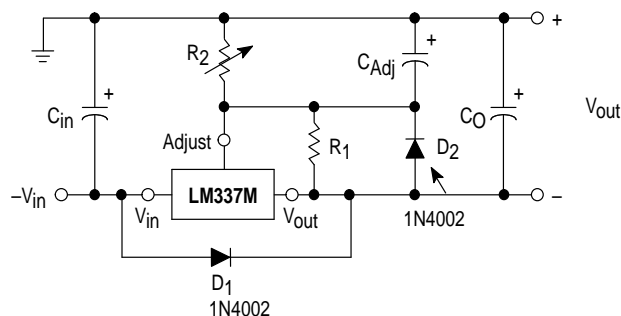

LM337M

OUTLINE DIMENSIONS

T SUFFIX
PLASTIC PACKAGE
CASE 221A-06
ISSUE Y

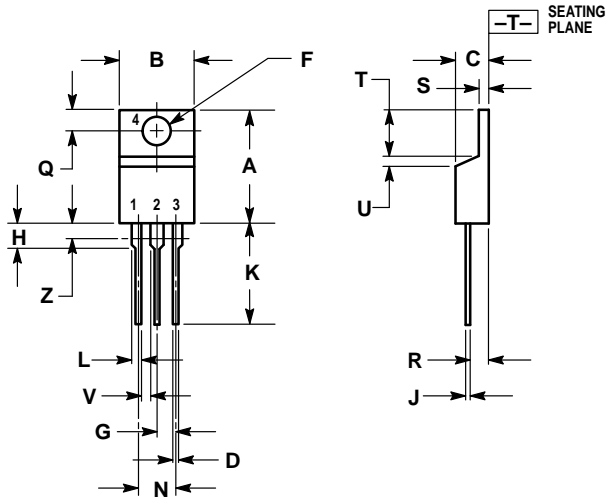

NOTES:

1. DIMENSIONING AND TOLERANCING PER ANSI Y14.5M, 1982.
2. CONTROLLING DIMENSION: INCH.
3. DIMENSION Z DEFINES A ZONE WHERE ALL BODY AND LEAD IRREGULARITIES ARE ALLOWED.

DIM	INCHES		MILLIMETERS	
	MIN	MAX	MIN	MAX
A	0.570	0.620	14.48	15.75
B	0.380	0.405	9.66	10.28
C	0.160	0.190	4.07	4.82
D	0.025	0.035	0.64	0.88
F	0.142	0.147	3.61	3.73
G	0.095	0.105	2.42	2.66
H	0.110	0.155	2.80	3.93
J	0.018	0.025	0.46	0.64
K	0.500	0.562	12.70	14.27
L	0.045	0.060	1.15	1.52
N	0.190	0.210	4.83	5.33
Q	0.100	0.120	2.54	3.04
R	0.080	0.110	2.04	2.79
S	0.045	0.055	1.15	1.39
T	0.235	0.255	5.97	6.47
U	0.000	0.050	0.00	1.27
V	0.045	—	1.15	—
Z	—	0.080	—	2.04

Motorola reserves the right to make changes without further notice to any products herein. Motorola makes no warranty, representation or guarantee regarding the suitability of its products for any particular purpose, nor does Motorola assume any liability arising out of the application or use of any product or circuit, and specifically disclaims any and all liability, including without limitation consequential or incidental damages. "Typical" parameters which may be provided in Motorola data sheets and/or specifications can and do vary in different applications and actual performance may vary over time. All operating parameters, including "Typicals" must be validated for each customer application by customer's technical experts. Motorola does not convey any license under its patent rights nor the rights of others. Motorola products are not designed, intended, or authorized for use as components in systems intended for surgical implant into the body, or other applications intended to support or sustain life, or for any other application in which the failure of the Motorola product could create a situation where personal injury or death may occur. Should Buyer purchase or use Motorola products for any such unintended or unauthorized application, Buyer shall indemnify and hold Motorola and its officers, employees, subsidiaries, affiliates, and distributors harmless against all claims, costs, damages, and expenses, and reasonable attorney fees arising out of, directly or indirectly, any claim of personal injury or death associated with such unintended or unauthorized use, even if such claim alleges that Motorola was negligent regarding the design or manufacture of the part. Motorola and registered trademarks of Motorola, Inc. Motorola, Inc. is an Equal Opportunity/Affirmative Action Employer.

How to reach us:

USA/EUROPE/Locations Not Listed: Motorola Literature Distribution; P.O. Box 20912; Phoenix, Arizona 85036. 1-800-441-2447 or 602-303-5454

MFAX: RMFAX0@email.sps.mot.com – TOUCHTONE 602-244-6609
INTERNET: <http://Design-NET.com>

JAPAN: Nippon Motorola Ltd.; Tatsumi-SPD-JLDC, 6F Seibu-Butsuryu-Center, 3-14-2 Tatsumi Koto-Ku, Tokyo 135, Japan. 03-81-3521-8315

ASIA/PACIFIC: Motorola Semiconductors H.K. Ltd.; 8B Tai Ping Industrial Park, 51 Ting Kok Road, Tai Po, N.T., Hong Kong. 852-26629298



LM337M/D

