

6367254 MOTOROLA SC (XSTRS/R F)

96D 82414

D 743-25

**MAXIMUM RATINGS**

Rating	Symbol	Value	Unit
Collector-Emitter Voltage	V <sub>CEO</sub>	50	Vdc
Collector-Base Voltage	V <sub>CB</sub>	75	Vdc
Emitter-Base Voltage	V <sub>EB</sub>	6.0	Vdc
Collector Current — Continuous	I <sub>C</sub>	800	mAdc
		Each Transistor	Total Device
M559-01 Total Power Dissipation @ T <sub>A</sub> = 25°C Derate above 25°C	P <sub>D</sub>	0.525 3.0	1.5 8.57 Watts mW/°C
M559-02 Total Power Dissipation @ T <sub>A</sub> = 25°C Derate above 25°C	P <sub>D</sub>	0.14 0.8	0.4 2.29 Watts mW/°C
Operating and Storage Junction Temperature Range	T <sub>J</sub> , T <sub>stg</sub>	-65 to +200	°C

**M559-01**  
**M559-02**



M559-01  
CERAMIC  
CASE 632-02  
STYLE 1

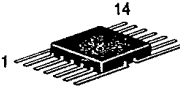

M559-02  
CERAMIC  
CASE 607-04  
STYLE 1

**QUAD  
TRANSISTORS**

NPN SILICON

5

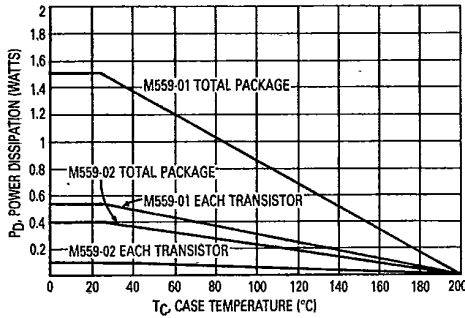

Figure 1. Power Temperature Derating Curve

Table 1. Product Classifications

JAN	— Controlled Lot with Sample Environmental and Life Testing
JTX	— 100% Processing Plus Sample Environmental and Life Testing
JTXV	— Same as JTX Plus 100% Internal Visual Inspection

**ELECTRICAL CHARACTERISTICS (T<sub>A</sub> = 25°C unless otherwise noted)**

Characteristic	Symbol	Min	Max	Unit
<b>OFF CHARACTERISTICS</b>				
Collector-Emitter Breakdown Voltage(1) (I <sub>C</sub> = 10 mAdc, I <sub>B</sub> = 0)	V <sub>(BR)CEO</sub>	50	—	Vdc
Collector-Base Breakdown Voltage (I <sub>C</sub> = 10 μAdc, I <sub>E</sub> = 0)	V <sub>(BR)CBO</sub>	75	—	Vdc
Emitter-Base Breakdown Voltage (I <sub>E</sub> = 10 μAdc, I <sub>C</sub> = 0)	V <sub>(BR)EBO</sub>	6.0	—	Vdc
Collector Cutoff Current (I <sub>E</sub> = 0, V <sub>CB</sub> = 60 Vdc) (I <sub>E</sub> = 0, V <sub>CB</sub> = 60 V, T <sub>A</sub> = 150°C)	I <sub>CBO</sub>	—	10 10	nAdc μA
Emitter Cutoff Current (I <sub>C</sub> = 0, V <sub>CB</sub> = 4.0 Vdc)	I <sub>EBO</sub>	—	10	nAdc
<b>ON CHARACTERISTICS</b>				
DC Current Gain(1) (I <sub>C</sub> = 0.1 mA, V <sub>CE</sub> = 10 Vdc) (I <sub>C</sub> = 1.0 mA, V <sub>CE</sub> = 10 Vdc) (I <sub>C</sub> = 10 mAdc, V <sub>CE</sub> = 10 Vdc) (I <sub>C</sub> = 150 mAdc, V <sub>CE</sub> = 10 Vdc) (I <sub>C</sub> = 500 mAdc, V <sub>CE</sub> = 10 Vdc) (I <sub>C</sub> = 10 mA, V <sub>CE</sub> = 10 V, T <sub>A</sub> = -55°C)	h <sub>FE</sub>	50 75 100 100 30 35	— 325 — 300 — —	
Collector-Emitter Saturation Voltage (I <sub>C</sub> = 150 mAdc, I <sub>B</sub> = 15 mAdc) (I <sub>C</sub> = 500 mAdc, I <sub>B</sub> = 50 mAdc)	V <sub>CE(sat)</sub>	— —	0.3 1.0	Vdc
Base-Emitter Saturation Voltage (I <sub>C</sub> = 150 mAdc, I <sub>B</sub> = 15 mAdc) (I <sub>C</sub> = 500 mAdc, I <sub>B</sub> = 50 mAdc)	V <sub>BE(sat)</sub>	0.6 —	1.2 2.0	Vdc
<b>DYNAMIC CHARACTERISTICS</b>				
Current-Gain — Bandwidth Product(1) (I <sub>C</sub> = 20 mAdc, V <sub>CE</sub> = 10 Vdc, f = 100 MHz)	f <sub>T</sub>	250	800	MHz
Output Capacitance (V <sub>CB</sub> = 10 Vdc, I <sub>E</sub> = 0, f = 1.0 MHz)	C <sub>obo</sub>	—	8.0	pF
Input Capacitance (V <sub>BE</sub> = 0.5 Vdc, I <sub>C</sub> = 0, f = 1.0 MHz)	C <sub>ibo</sub>	—	25	pF

MOTOROLA SMALL-SIGNAL SEMICONDUCTORS

M559-01, M559-02

T-43-25

**ELECTRICAL CHARACTERISTICS** (continued) ( $T_A = 25^\circ\text{C}$  unless otherwise noted)

Characteristic	Symbol	Min	Max	Unit
<b>SWITCHING CHARACTERISTICS</b>				
Turn-On Time ( $V_{CC} = 30\text{ Vdc}$ , $V_{BE(\text{off})} = 0.5\text{ Vdc}$ , $I_C = 150\text{ mAdc}$ , $I_{B1} = 15\text{ mAdc}$ ) (Figure 2)	$t_{on}$	—	35	ns
Turn-Off Time ( $V_{CC} = 30\text{ Vdc}$ , $I_C = 150\text{ mAdc}$ , $I_{B1} = I_{B2} = 15\text{ mAdc}$ ) (Figure 3)	$t_{off}$	—	300	ns

(1) Pulse Test: Pulse Width  $\leq 300\ \mu\text{s}$ , Duty Cycle = 2.0%.

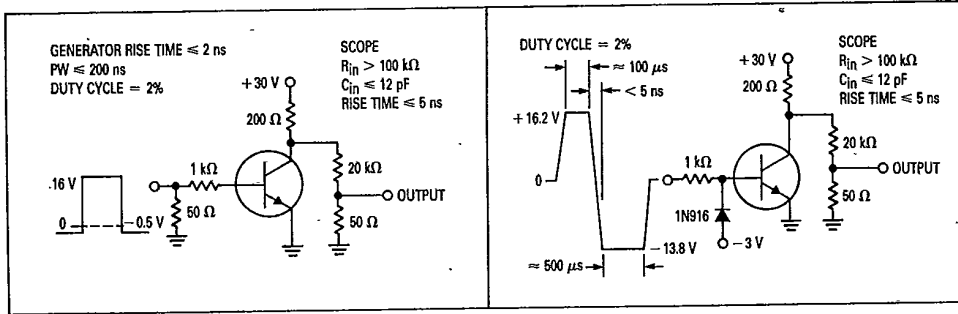

Figure 2.  $t_{on}$  Test Circuit

Figure 3.  $t_{off}$  Test Circuit

Table 2. JTX, JTXV 100% Processing Steps

	JTX	JTXV
Internal Visual (Mil-Std-750, Method 2072)	—	100%
High Temperature Storage (Mil-Std-750, Method 1032)	100%	100%
Thermal Shock (Mil-Std-750, Method 1051 Cond. F*)	100%	100%
Constant Acceleration (Mil-Std-750, Method 2006, 20 KG <sup>2</sup> , Y <sub>1</sub> )	100%	100%
Hermetic Seal (Fine + Gross Leak) (Mil-Std-750, Method 1071, Cond. G or H)**	100%	100%
READ Electrical Parameters (Group A)	100%	100%
High Temperature Reverse Bias (Mil-Std-750, Method 1039, Cond. A)	100%	100%
READ Electrical Parameters (Group A)	100%	100%
Power Burn-In (Mil-Std-750, Method 1039, Cond. B)	100%	100%
READ Electrical Parameters (Group A)	100%	100%

\*T(LOW) =  $-55^\circ\text{C}$   
 \*\*Cond. G, Fine Leak =  $1 \times 10^{-7}$  ATM. CC/sec.

Table 3. Simplified Hi-Rel Product Flow

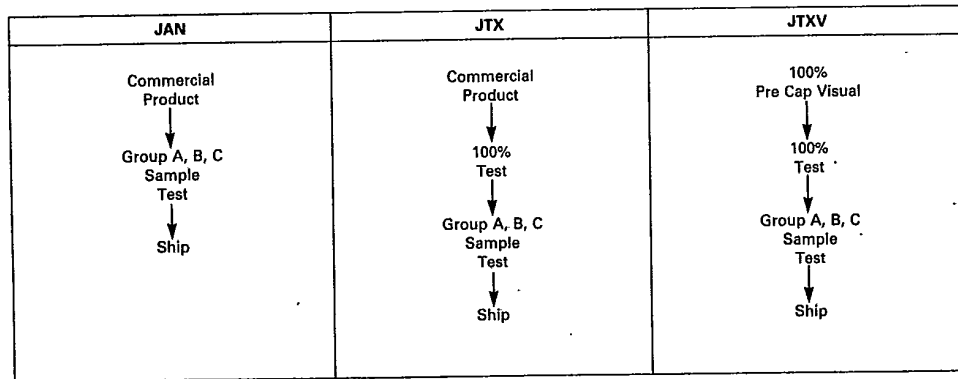

6367254 MOTOROLA SC (XSTRS/R F)

96D 82421 D  
T-29-27

MAXIMUM RATINGS				
Rating	Symbol	Value		Unit
Collector-Emitter Voltage	V <sub>CEO</sub>	15		Vdc
Collector-Base Voltage	V <sub>CBO</sub>	40		Vdc
Emitter-Base Voltage	V <sub>EBO</sub>	5.0		Vdc
Collector Current — Continuous	I <sub>C</sub>	200		mAdc
		One Die	Both Die Equal Power	
Total Device Dissipation @ T <sub>A</sub> = 25°C MD708, MD708A, MD708B MD708F, MD708AF, MD708BF Derate above 25°C MD708, MD708A, MD708B MD708F, MD708AF, MD708BF	P <sub>D</sub>			mW
		550	600	
		350	400	mW/°C
		3.13	3.42	
Total Device Dissipation @ T <sub>C</sub> = 25°C MD708, MD708A, MD708B MD708F, MD708AF, MD708BF Derate above 25°C MD708, MD708A, MD708B MD708F, MD708AF, MD708BF	P <sub>D</sub>			Watts
		1.4	2.0	
		0.7	1.4	mW/°C
		8.0	11.4	
Operating and Storage Junction Temperature Range	T <sub>J</sub> , T <sub>stg</sub>	- 65 to +200		°C

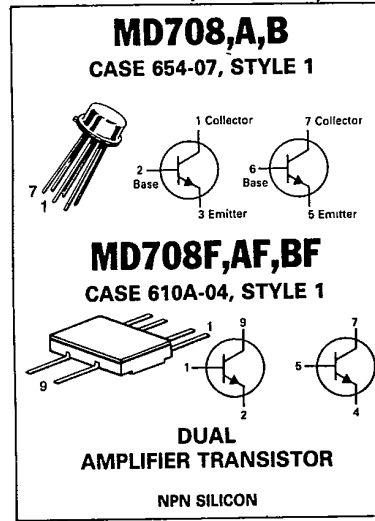

Refer to MD2369 for graphs.

**THERMAL CHARACTERISTICS**

Characteristic	Symbol	One Die	Both Die Equal Power	Unit
Thermal Resistance, Junction to Case MD708, MD708A, MD708B MD708F, MD708AF, MD708BF	R <sub>θJC</sub>	125	87.5	°C/W
		250	125	
Thermal Resistance, Junction to Ambient	R <sub>θJA</sub> (1)	319	292	°C/W
		500	438	
Coupling Factors		Junction to Ambient	Junction to Case	%
		83	40	
		75	0	

(1) R<sub>θJA</sub> is measured with the device soldered into a typical printed circuit board.

**ELECTRICAL CHARACTERISTICS (T<sub>A</sub> = 25°C unless otherwise noted.)**

Characteristic	Symbol	Min	Max	Unit
<b>OFF CHARACTERISTICS</b>				
Collector-Emitter Breakdown Voltage(2) (I <sub>C</sub> = 30 mAdc, I <sub>B</sub> = 0)	V <sub>(BR)CEO</sub>	15	—	Vdc
Collector-Base Breakdown Voltage (I <sub>C</sub> = 10 μAdc, I <sub>E</sub> = 0)	V <sub>(BR)CBO</sub>	40	—	Vdc
Emitter-Base Breakdown Voltage (I <sub>E</sub> = 10 μAdc, I <sub>C</sub> = 0)	V <sub>(BR)EBO</sub>	5.0	—	Vdc
Collector Cutoff Current (V <sub>CB</sub> = 20 Vdc, I <sub>E</sub> = 0)	I <sub>CBO</sub>	—	15	nAdc
		(V <sub>CB</sub> = 20 Vdc, I <sub>E</sub> = 0, T <sub>A</sub> = 150°C)	30	μAdc
<b>ON CHARACTERISTICS</b>				
DC Current Gain(2)	h <sub>FE</sub>	(I <sub>C</sub> = 500 μAdc, V <sub>CE</sub> = 1.0 Vdc)	40	—
		(I <sub>C</sub> = 10 mAdc, V <sub>CE</sub> = 1.0 Vdc)	40	200
		(I <sub>C</sub> = 100 mAdc, V <sub>CE</sub> = 5.0 Vdc)	35	—
		(I <sub>C</sub> = 150 mAdc, V <sub>CE</sub> = 5.0 Vdc)	20	—
Collector-Emitter Saturation Voltage	V <sub>CE(sat)</sub>	(I <sub>C</sub> = 10 mAdc, I <sub>B</sub> = 1.0 mAdc)	—	0.20
		(I <sub>C</sub> = 50 mAdc, I <sub>B</sub> = 5.0 mAdc)	—	0.35
		(I <sub>C</sub> = 100 mAdc, I <sub>B</sub> = 10 mAdc)	—	0.50
Base-Emitter Saturation Voltage	V <sub>BE(sat)</sub>	(I <sub>C</sub> = 10 mAdc, I <sub>B</sub> = 1.0 mAdc)	0.65	0.85
		(I <sub>C</sub> = 50 mAdc, I <sub>B</sub> = 5.0 mAdc)	—	0.95
		(I <sub>C</sub> = 100 mAdc, I <sub>B</sub> = 10 mAdc)	—	1.10

(2) Pulse Test: Pulse Width ≤ 300 μs, Duty Cycle ≤ 2.0%.

6367254 MOTOROLA SC (XSTRS/R F)

96D 82422 D

T-29-27

**MAXIMUM RATINGS**

Rating	Symbol	Value	Unit
Collector-Emitter Voltage	V <sub>CEO</sub>	15	Vdc
Collector-Base Voltage	V <sub>CES</sub>	30	Vdc
Emitter-Base Voltage	V <sub>EBO</sub>	3.0	Vdc
Collector Current — Continuous	I <sub>C</sub>	50	mAdc
		One Die	Both Die
Total Device Dissipation @ T <sub>A</sub> = 25°C MD918,A,B MD918AF Derate above 25°C MD918,A,B MD918AF	P <sub>D</sub>	550 350 3.14 2.0	600 400 3.42 2.28 mW mW/°C
Total Device Dissipation @ T <sub>C</sub> = 25°C MD918,A,B MD918AF Derate above 25°C MD918,A,B MD918AF	P <sub>D</sub>	1.4 0.7 8.0 4.0	2.0 1.4 11.4 8.0 Watts mW/°C
Operating and Storage Junction Temperature Range	T <sub>J</sub> , T <sub>stg</sub>	-65 to +200	°C

**MD918  
MD918A  
MD918B**



CASE 654-07, STYLE 1

**MD918AF**

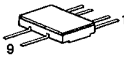

CASE 610A-04, STYLE 1

**DUAL  
AMPLIFIER TRANSISTOR**

NPN SILICON

5

**THERMAL CHARACTERISTICS**

Characteristic	Symbol	One Die	All Die Equal Power	Unit
Thermal Resistance, Junction to Case MD918,A,B MD918AF	R <sub>θJC</sub>	125 250	87.5 125	°C/W
Thermal Resistance, Junction to Ambient MD918,A,B MD918AF	R <sub>θJA</sub> (1)	319 500	292 438	°C/W
		Junction to Ambient	Junction to Case	
Coupling Factors MD918,A,B MD918AF		83 75	40 0	%

(1) R<sub>θJA</sub> is measured with the device soldered into a typical printed circuit board.

**ELECTRICAL CHARACTERISTICS (T<sub>A</sub> = 25°C unless otherwise noted.)**

Characteristic	Symbol	Min	Typ	Max	Unit
<b>OFF CHARACTERISTICS</b>					
Collector-Emitter Breakdown Voltage(2) (I <sub>C</sub> = 3.0 mAdc, I <sub>B</sub> = 0)	V <sub>(BR)CEO</sub>	15	—	—	Vdc
Collector-Base Breakdown Voltage (I <sub>C</sub> = 1.0 μAdc, I <sub>E</sub> = 0)	V <sub>(BR)CBO</sub>	30	—	—	Vdc
Emitter-Base Breakdown Voltage (I <sub>E</sub> = 10 μAdc, I <sub>C</sub> = 0)	V <sub>(BR)EBO</sub>	3.0	—	—	Vdc
Collector Cutoff Current (V <sub>CB</sub> = 15 Vdc, I <sub>E</sub> = 0) (V <sub>CB</sub> = 15 Vdc, I <sub>E</sub> = 0, T <sub>A</sub> = 150°C)	I <sub>CBO</sub>	—	—	10 1.0	nAdc μAdc
<b>ON CHARACTERISTICS</b>					
DC Current Gain (I <sub>C</sub> = 3.0 mAdc, V <sub>CE</sub> = 5.0 Vdc)	h <sub>FE</sub>	50	165	—	—
Collector-Emitter Saturation Voltage (I <sub>C</sub> = 10 mAdc, I <sub>B</sub> = 1.0 Adc)	V <sub>CE(sat)</sub>	—	0.09	0.2	Vdc
Base-Emitter Saturation Voltage (I <sub>C</sub> = 10 mAdc, I <sub>B</sub> = 1.0 mAdc)	V <sub>BE(sat)</sub>	—	0.86	0.9	Vdc
<b>SMALL-SIGNAL CHARACTERISTICS</b>					
Current-Gain — Bandwidth Product (I <sub>C</sub> = 4.0 mAdc, V <sub>CE</sub> = 10 Vdc, f = 100 MHz)	f <sub>T</sub>	600	—	—	MHz
Output Capacitance (V <sub>CB</sub> = 10 Vdc, I <sub>E</sub> = 0, f = 100 kHz)	C <sub>obo</sub>	—	1.1	1.7	pF

MOTOROLA SMALL-SIGNAL SEMICONDUCTORS

6367254 MOTOROLA SC (XSTRS/R F)

96D 82423 D

MD918,A,B,AF

T-29-27

ELECTRICAL CHARACTERISTICS (continued) (T<sub>A</sub> = 25°C unless otherwise noted.)

Characteristic	Symbol	Min	Typ	Max	Unit
Input Capacitance (V <sub>BE</sub> = 0.5 Vdc, I <sub>C</sub> = 0, f = 100 kHz)	C <sub>ibo</sub>	—	1.15	2.0	pF
Noise Figure (I <sub>C</sub> = 1.0 mAdc, V <sub>CE</sub> = 6.0 Vdc, R <sub>S</sub> = 400Ω, f = 60 MHz)	NF	—	—	6.0	dB

MATCHING CHARACTERISTICS

DC Current Gain Ratio(3) (I <sub>C</sub> = 1.0 mAdc, V <sub>CE</sub> = 5.0 Vdc)	MD918B MD918A,AF	h <sub>FE1</sub> /h <sub>FE2</sub>	0.8 0.9	— —	1.0 1.0	—
Base-Emitter Voltage Differential (I <sub>C</sub> = 1.0 mAdc, V <sub>CE</sub> = 5.0 Vdc)	MD918B MD918A,AF	V <sub>BE1</sub> -V <sub>BE2</sub>	— —	— —	10 5.0	mVdc
Base-Emitter Voltage Differential Gradient (I <sub>C</sub> = 1.0 mAdc, V <sub>CE</sub> = 5.0 Vdc, T <sub>A</sub> = -55 to +125°C)	MD918B,AF MD918A	$\frac{\Delta(V_{BE1}-V_{BE2})}{\Delta T_A}$	— —	— —	20 10	μV/dc °C

(2) Pulse Test: Pulse Width ≤ 300 μs, Duty Cycle ≤ 2.0%.  
 (3) The lowest h<sub>FE</sub> reading is taken as h<sub>FE1</sub> for this ratio.



FIGURE 1 - DC CURRENT GAIN

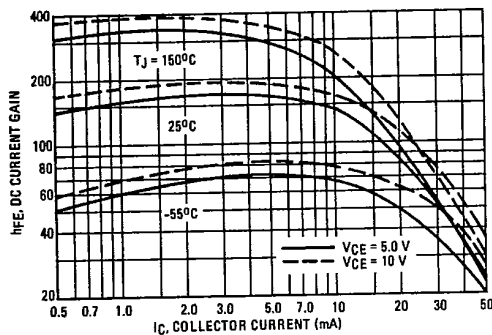

FIGURE 2 - "ON" VOLTAGES

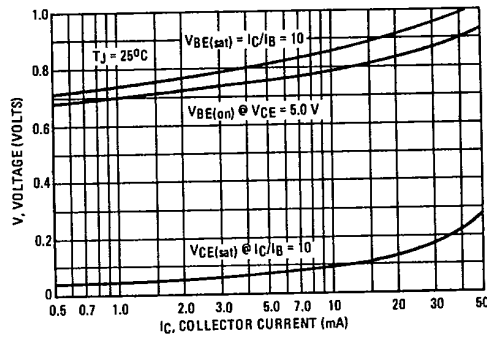

FIGURE 3 - BASE-EMITTER TEMPERATURE COEFFICIENT

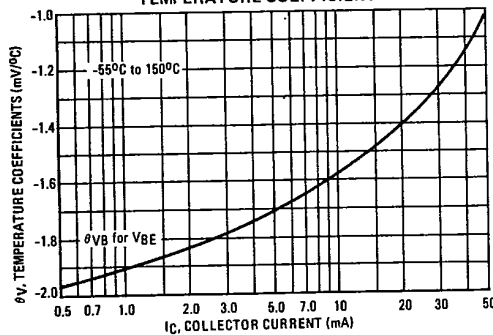
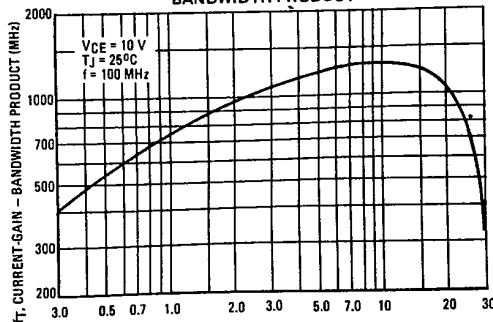

FIGURE 4 - CURRENT-GAIN BANDWIDTH PRODUCT



6367254 MOTOROLA SC (XSTRS/R F)

96D 82424 D

MD918,A,B,AF

T-29-27

FIGURE 5 - CAPACITANCE

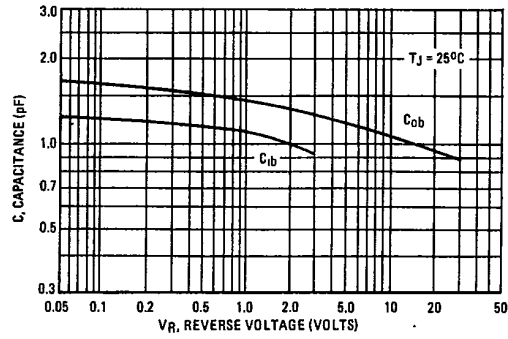

5