



Remote Control Amplifier/Detector

The MC3373 is intended for application in infrared remote controls. It provides the high gain and pulse shaping needed to couple the signal from an IR receiver diode to the tuning control system logic.

- High Gain Pre-Amp
- Envelope Detector for PCM Demodulation
- Simple Interface to Microcomputer Remote Control Decoder
- Use with Tuned Circuit for Narrow Bandwidth, Lower Noise Operation
- Minimum External Components
- Wide Operating Supply Voltage Range
- Low Current Drain
- Improved Retrofit for NEC Part No. μ PC1373
- MC14497 Recommended IR Transmitter
- MLED81 Complementary Emitter
- MRD821 Complementary Detector Diode

MC3373

REMOTE CONTROL WIDEBAND AMPLIFIER WITH DETECTOR

SEMICONDUCTOR TECHNICAL DATA



P SUFFIX PLASTIC PACKAGE CASE 826



D SUFFIX PLASTIC PACKAGE CASE 751 (SO-8)

PIN CONNECTIONS

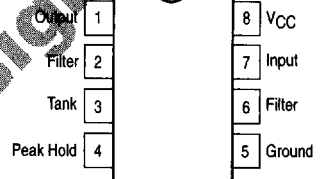

ORDERING INFORMATION

Device	Operating Temperature Range	Package
MC3373P	T _A = 0 to +75°C	Plastic DIP
MC3373D		SO-8

MAXIMUM RATINGS

Rating	Symbol	Value	Unit
Supply Voltage	VCC	15	Vdc
Operating Temperature Range	T _A	0 to +75	°C
Storage Temperature Range	T _{stg}	-65 to +125	°C
Junction Temperature	T _j	150	°C
Power Dissipation, Package Rating Derate above 25°C	P _D 1/8 J _A	1.25 10	W mW/°C

Figure 1. Remote Control Application
40 kHz Carrier

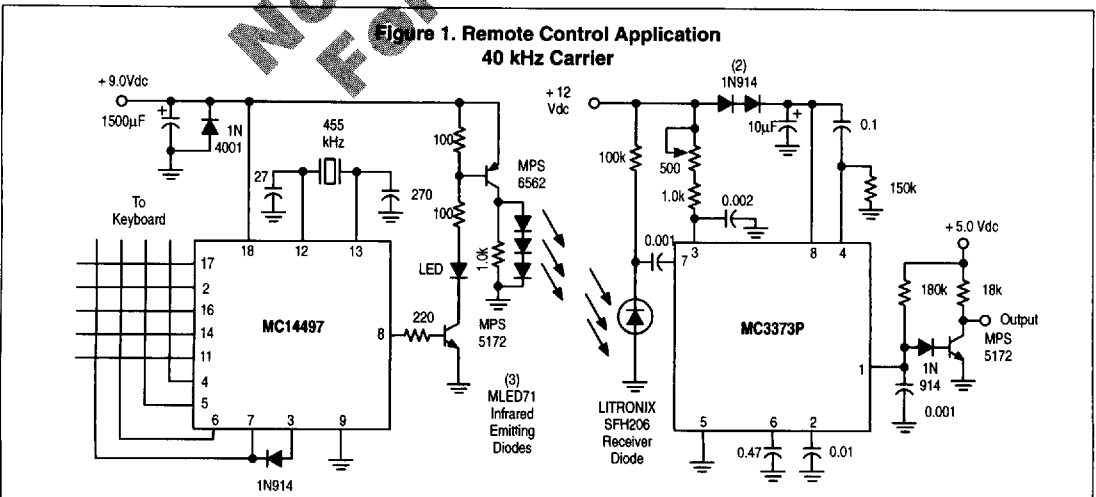

MC3373

RECOMMENDED OPERATING CONDITIONS

Characteristics	Symbol	Min	Typ	Max	Unit
Power Supply Voltage (25°C)	V_{CC}	4.75	—	15	Vdc
Power Supply Voltage (0°C)	V_{CC}	5.0	—	15	Vdc
Input Frequency	f_{in}	30	40	80	kHz

ELECTRICAL CHARACTERISTICS ($T_A = 25^\circ\text{C}$, $V_{CC} = 5.0\text{ V}$, $f_{in} = 40\text{ kHz}$, Test circuit of Figure 2)

Characteristics	Symbol	Min	Typ	Max	Unit
Power Supply Current	I_{CC}	1.5	2.5	3.5	mAdc
Input Terminal Voltage	$V(\text{Pin } 7)$	2.4	2.8	3.0	Vdc
Input Voltage Threshold	V_{in}	—	50	100	μVpp
Input Amplifier Voltage Gain ($V(\text{Pin } 3) = 500\text{ mVpp}$)	A_V	—	60	—	dB
Input Impedance	r_{in}	40	60	80	$\text{k}\Omega$
Output Voltage, $V_{in} = 1.0\text{ mVpp}$	V_{OL}	—	—	0.5	V
Output Leakage, $V_{CC} = V_{OH} = 15\text{ Vdc}$	I_{OH}	—	—	2.0	μA
Output Voltage, Input Open	V_{OH}	—	—	5.0	Vdc

Figure 2. Test Circuit

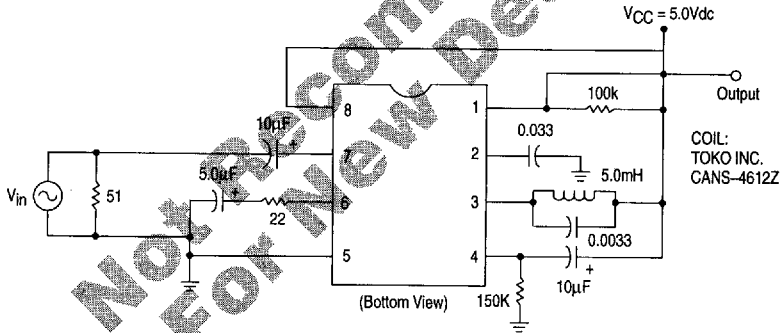

Figure 3. Representative Block Diagram

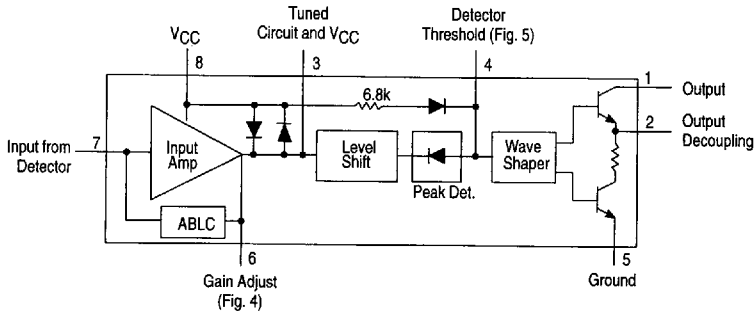

Figure 4. Input Amplifier Gain

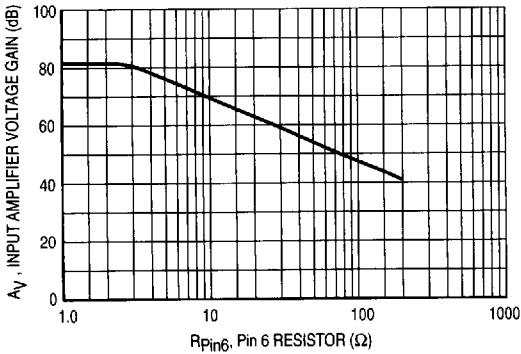
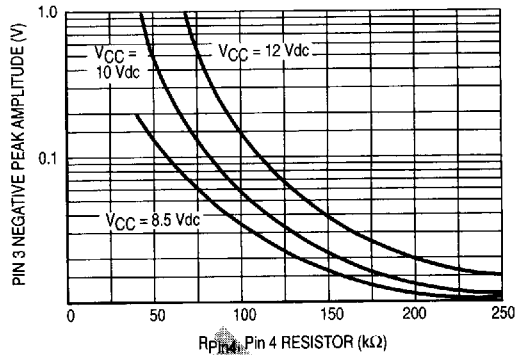

Figure 5. Detector Threshold



APPLICATIONS INFORMATION

The MC3373 is a specialized high gain amplifier/signal processor bipolar analog IC designed to be the core of infrared carrier signaling systems. The amplifier section has an Automatic Bias Level Control (ABLC) for simplified direct connection to an IR detector diode. Generally, it is operated ac coupled, utilizing an input high-pass filter to eliminate power line related noise, particularly that from florescent and gas vapor lamps. The use of a high frequency carrier is strongly recommended as opposed to simply detecting "dc" bursts of IR energy. In the carrier mode setup the MC3373 acts like an AM receiver subsystem, amplifying the incoming signal, demodulating it, and providing some basic wave shaping of the demodulated envelope. The tuned circuit at Pin 3 provides the main system selectivity reducing random noise interference and permitting multichannel operation in the same physical area without falsing. In the multichannel case the carriers must not be harmonically related. The bandwidth is determined primarily by the "Q" of the coil. Bandwidth may be increased by loading, shunting, the coil with a resistor.

Since this is a very high gain system operating at relatively high frequencies, care **must** be taken in the circuit layout and construction. Do not use wire wrap or non-ground plane protoboard. A simple single sided PCB with ground fill or a two-sided board with a solid groundplane and top side point-to-point will provide consistent high performance. There is a wide array of IR emitter/detectors available. The Motorola MLED81 and MRD821 are an excellent low cost combination to use with the MC3373. Multiple emitters are recommended for extended range.

Figure 6. Typical Signal Waveforms

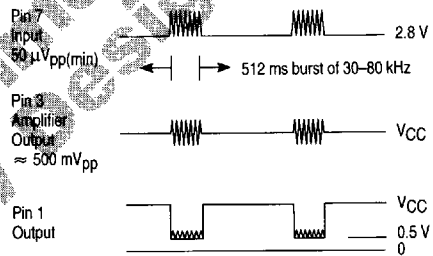

The input amplifier gain is approximately equal to the load impedance at Pin 3, divided by the resistor from Pin 6 to ground. Again, the low frequency gain can be reduced by using a small coupling capacitor in series with the Pin 6 resistor.

The load may be resistive, with only, or tuned, as in the test circuit. The amplifier output is limited by back-to-back clamping diodes, level shifted, and fed to a negative peak detector. The detector threshold is set by the external resistor on Pin 4, and an internal 6.8 kΩ resistor and diode to VCC. The capacitor from VCC to Pin 4 quickly charges during the negative peaks and then settles toward the set-up voltage between signal bursts at a rate roughly determined by the value of the capacitor and the 6.8 k resistor. The external capacitor at Pin 2 filters the ultrasonic carrier from the pulses.

MC3373

CIRCUIT DESCRIPTION

Q1 to Q4 set the bias on the amplifier input at approximately 2.8 V. Q6 to Q10 form the input amplifier, which has a gain of about 80 dB when $R(\text{Pin } 6) = 0$, Q5 sinks input current from the photo diode and keeps the amplifier properly

biased. Q18 to Q20 level shift and buffer the signal to the negative peak detector, Q22 and Q23. Output devices Q26 and Q27 conduct during peaks and pull the output (Pin 1) low. The capacitor on Pin 2 filters out the carrier.

Figure 7. Representative Schematic Diagram

