

PowerPC™

Advance Information PowerPC 604e™ RISC Microprocessor Family: PID9q-604e Hardware Specifications

The PowerPC 604e microprocessor is an implementation of the PowerPC® family of reduced instruction set computing (RISC) microprocessors. In this document, the term '604' is used as an abbreviation for 'PowerPC 604™ microprocessor' and the term '604e' is used as an abbreviation for 'PowerPC 604e microprocessor'. The PowerPC 604e microprocessors are available from Motorola as MPC604e and from IBM as PPC604e. When ordering, note that PID9q-604e processors prior to revision 1.1 are referenced as the PID10q-604e. This document contains pertinent physical characteristics of the 604e.

This document contains the following topics:

Topic	Page
Section 1.1, "Overview"	2
Section 1.2, "Features"	2
Section 1.3, "General Parameters"	5
Section 1.4, "Electrical and Thermal Characteristics"	6
Section 1.5, "Pin Assignments"	16
Section 1.6, "Pinout Listings"	17
Section 1.7, "Package Description"	19
Section 1.8, "System Design Information"	20
Section 1.9, "Ordering Information"	27

To locate any published errata or updates for this document, refer to the website at <http://www.mot.com/SPS/PowerPC/> or at <http://www.chips.ibm.com/products/ppc>.

The PowerPC name is a registered trademark and the PowerPC logotype, PowerPC 604 and PowerPC 604e are trademarks of International Business Machines Corporation, used by Motorola under license from International Business Machines Corporation. FLOTHERM is a registered trademark of Flomerics Ltd., UK.

This document contains information on a new product under development by Motorola and IBM. Motorola and IBM reserve the right to change or discontinue this product without notice.

© Motorola Inc., 1997. All rights reserved.

Portions hereof © International Business Machines Corporation, 1991–1997. All rights reserved.



1.1 Overview

The 604e is an implementation of the PowerPC family of reduced instruction set computing (RISC) microprocessors. The 604e implements the PowerPC architecture as it is specified for 32-bit addressing, which provides 32-bit effective (logical) addresses, integer data types of 8, 16, and 32 bits, and floating-point data types of 32 and 64 bits (single-precision and double-precision). For 64-bit PowerPC implementations, the PowerPC architecture provides additional 64-bit integer data types, 64-bit addressing, and related features.

The 604e is a superscalar processor capable of issuing four instructions simultaneously. As many as seven instructions can finish execution in parallel. The 604e has seven execution units that can operate in parallel—a floating-point unit (FPU), a branch processing unit (BPU), a condition register unit (CRU), a load/store unit (LSU), and three integer units (IUs)—two single-cycle integer units (SCIUs) and one multiple-cycle integer unit (MCIU).

This parallel design, combined with the PowerPC architecture's specification of uniform instructions that allows for rapid execution times, yields high efficiency and throughput. The 604e's rename buffers, reservation stations, dynamic branch prediction, and completion unit increase instruction throughput, guarantee in-order completion, and ensure a precise exception model. (Note that the PowerPC architecture specification refers to all exceptions as interrupts.)

The 604e has separate memory management units (MMUs) and separate 32-Kbyte on-chip caches for instructions and data. The 604e implements two 128-entry, two-way set associative translation lookaside buffers (TLBs), one for instructions and one for data, and provides support for demand-paged virtual memory address translation and variable-sized block translation. The TLBs and the cache use least-recently used (LRU) replacement algorithms.

The 604e has a 64-bit external data bus and a 32-bit address bus. The 604e interface protocol allows multiple masters to compete for system resources through a central external arbiter. Additionally, on-chip snooping logic maintains data cache coherency for multiprocessor applications. The 604e supports single-beat and burst data transfers for memory accesses and memory-mapped I/O accesses.

The 604e uses an advanced, 1.9V CMOS process technology and is fully compatible with 3.3V TTL devices.

1.2 Features

This section summarizes features of the 604e's implementation of the PowerPC architecture. Major features of the 604e are as follows:

- High-performance, superscalar microprocessor
 - As many as four instructions can be issued per clock
 - As many as seven instructions can start executing per clock (including three integer instructions)
 - Single-clock-cycle execution for most instructions

- Seven independent execution units and two register files
 - BPU featuring dynamic branch prediction
 - Two-entry reservation station
 - Out-of-order execution through two branches
 - Shares dispatch bus with CRU
 - 64-entry fully-associative branch target address cache (BTAC). In the 604e, the BTAC can be disabled and invalidated.
 - 512-entry branch history table (BHT) with two bits per entry for four levels of prediction— not-taken, strongly not-taken, taken, strongly taken
 - Condition register logical unit
 - Two-entry reservation station
 - Shares dispatch bus with BPU
 - Two single-cycle IUs (SCIUs) and one multiple-cycle IU (MCIU)
 - Instructions that execute in the SCIU take one cycle to execute; most instructions that execute in the MCIU take multiple cycles to execute.
 - Each SCIU has a two-entry reservation station to minimize stalls
 - The MCIU has a single-entry reservation station and provides early exit (three cycles) for 16- x 32-bit and overflow operations.
 - Thirty-two GPRs for integer operands
 - Three-stage floating-point unit (FPU)
 - Fully IEEE 754-1985-compliant FPU for both single- and double-precision operations
 - Supports non-IEEE mode for time-critical operations
 - Fully pipelined, single-pass double-precision design
 - Hardware support for denormalized numbers
 - Two-entry reservation station to minimize stalls
 - Thirty-two 64-bit FPRs for single- or double-precision operands
 - Load/store unit (LSU)
 - Two-entry reservation station to minimize stalls
 - Single-cycle, pipelined cache access
 - Dedicated adder performs effective address (EA) calculations
 - Performs alignment and precision conversion for floating-point data
 - Performs alignment and sign extension for integer data
 - Four-entry finish load queue (FLQ) provides load miss buffering
 - Six-entry store queue
 - Supports both big- and little-endian modes
- Rename buffers
 - Twelve GPR rename buffers
 - Eight FPR rename buffers
 - Eight condition register (CR) rename buffers

- Completion unit
 - The completion unit retires an instruction from the 16-entry reorder buffer when all instructions ahead of it have been completed and the instruction has finished execution.
 - Guarantees sequential programming model (precise exception model)
 - Monitors all dispatched instructions and retires them in order
 - Tracks unresolved branches and flushes executed, dispatched, and fetched instructions if branch is mispredicted
 - Retires as many as four instructions per clock
- Separate on-chip instruction and data caches (Harvard architecture)
 - 32-Kbyte, four-way set-associative instruction and data caches
 - LRU replacement algorithm
 - 32-byte (eight-word) cache block size
 - Physically indexed/physical tags. (Note that the PowerPC architecture refers to physical address space as real address space.)
 - Cache write-back or write-through operation programmable on a per page or per block basis
 - Instruction cache can provide four instructions per clock; data cache can provide two words per clock
 - Caches can be disabled in software
 - Caches can be locked
 - Parity checking performed on both caches
 - Data cache coherency (MESI) maintained in hardware
 - Secondary data cache support provided
 - Instruction cache coherency maintained in hardware
 - Data cache line-fill buffer forwarding. In the 604 only the critical double word of the cache block was made available to the requesting unit at the time it was burst into the line-fill buffer. Subsequent data was unavailable until the cache block was filled. On the 604e, subsequent data is also made available as it arrives in the line-fill buffer.
- Separate memory management units (MMUs) for instructions and data
 - Address translation facilities for 4-Kbyte page size, variable block size, and 256-Mbyte segment size
 - Both TLBs are 128-entry and two-way set associative
 - TLBs are hardware reloadable (that is, the page table search is performed in hardware)
 - Separate IBATs and DBATs (four each) also defined as SPRs
 - Separate instruction and data translation lookaside buffers (TLBs)
 - LRU replacement algorithm
 - 52-bit virtual address; 32-bit physical address
- Bus interface features include the following:
 - Selectable processor-to-bus clock frequency ratios (1:1, 3:2, 2:1, 5:2, 3:1, 7:2, 4:1, 9:2, 5:1, 11:2, 6:1, 13:2, and 7:1)
 - A 64-bit split-transaction external data bus with burst transfers
 - Support for address pipelining and limited out-of-order bus transactions

- Four burst write queues—three for cache copyback operations and one for snoop push operations
- Two single-beat write queues
- Additional signals and signal redefinition for direct-store operations
- Provides a data streaming mode that allows consecutive burst read data transfers to occur without intervening dead cycles. This mode also disables data retry operations.
- No- $\overline{\text{DRTRY}}$ mode eliminates the $\overline{\text{DRTRY}}$ signal from the qualified bus grant and allows read operations. This improves performance on read operations for systems that do not use the $\overline{\text{DRTRY}}$ signal. No- $\overline{\text{DRTRY}}$ mode makes read data available to the processor one bus clock cycle sooner than if normal mode is used.
- Multiprocessing support features include the following:
 - Hardware enforced, four-state cache coherency protocol (MESI) for data cache. Bits are provided in the instruction cache to indicate only whether a cache block is valid or invalid.
 - Separate port into data cache tags for bus snooping
 - Load/store with reservation instruction pair for atomic memory references, semaphores, and other multiprocessor operations
- Power management
 - NAP mode supports full shut down and snooping
 - Operating voltage of $1.9 \pm 100 \text{ mV}$
- Performance monitor can be used to help in debugging system designs and improving software efficiency, especially in multiprocessor systems.
- In-system testability and debugging features through JTAG boundary-scan capability

1.3 General Parameters

The following list provides a summary of the general parameters of the 604e:

Technology	0.25 μm CMOS, five-layer metal
Die size	6.97 mm x 6.75mm (47 mm ²)
Transistor count	5.1 million
Logic design	Fully-static
Package	Surface mount 255-lead ceramic ball grid array (CBGA)
Core power supply	1.9 V \pm 100 mV dc
I/O power supply	3.3 V \pm 5% V dc

1.4 Electrical and Thermal Characteristics

This section provides both the AC and DC electrical specifications and thermal characteristics for the 604e.

1.4.1 DC Electrical Characteristics

The tables in this section describe the 604e DC electrical characteristics. Table 1 provides the absolute maximum ratings.

Table 1. Absolute Maximum Ratings

Characteristic	Symbol	Value	Unit
Core supply voltage	V _{dd}	-0.3 to 2.80	V
PLL supply voltage	AV _{dd}	-0.3 to 2.80	V
I/O supply voltage	OV _{dd}	-0.3 to 3.8	V
Input voltage	V _{in}	-0.3 to 3.3	V
Overshoot (with respect to system GND)	V _{ovs}	4.0	V
Undershoot (with respect to system GND)	V _{uns}	-0.45	V
Storage temperature range	T _{stg}	-55 to 150	°C

Notes:

1. Functional and tested operating conditions are given in Table 2. Absolute maximum ratings are stress ratings only, and functional operation at the maximums is not guaranteed. Stresses beyond those listed may affect device reliability or cause permanent damage to the device.
2. **Caution:** Power up/down sequence must be adhered to to avoid device damage.
 - The power-up sequence is GND, V_{dd}, OV_{dd}
 - The power-down sequence is OV_{dd}, V_{dd}, GNDIn either case the rule $OV_{dd} - V_{dd} \leq 2.0V$ must be followed.
3. **Caution:** During system power-up, any 604e signal – V_{DD}core must not exceed 2.0V
4. **Caution:** 604e inputs are not 5V tolerant.

Table 2 provides the recommended operating conditions for the 604e.

Table 2. Recommended Operating Conditions

Characteristic	Symbol	Value	Unit
Core supply voltage	V _{dd}	1.8 to 2.0	V
PLL supply voltage	AV _{dd}	1.8 to 2.0	V
I/O supply voltage	OV _{dd}	3.135 to 3.465	V
Input voltage	V _{in}	GND to 3.3	V
Junction temperature	T _j	0 to 105	°C

Note: These are the recommended and tested operating conditions. Proper device operation outside of these conditions is not guaranteed.

Table 3 provides the thermal characteristics for the 604e.

Table 3. Thermal Characteristics

Characteristic	Symbol	Value	Rating
CBGA package thermal resistance, junction-to-top of die	θ_{JC}	0.03	°C/W

Note: Refer to Section 1.8, “System Design Information,” for more details about thermal management.

Table 4 provides the DC electrical characteristics for the 604e.

Table 4. DC Electrical Specifications

Vdd = AVdd = 1.9 ±100 mV dc, OVdd = 3.3 ± 5% V dc, GND = 0 V dc, 0 ≤ Tj ≤ 105 °C

Characteristic	Symbol	Min	Max	Unit
Input high voltage (all inputs except SYSCLK)	V _{IH}	2.0	3.465	V
Input low voltage (all inputs except SYSCLK)	V _{IL}	0.0	0.8	V
SYSCLK input high voltage	CV _{IH}	2.4	3.465	V
SYSCLK input low voltage	CV _{IL}	0.0	0.4	V
Input leakage current, V _{in} = 3.3 V ¹	I _{in}	—	10	μA
Hi-Z (off-state) leakage current, V _{in} = 3.3 V ¹	I _{TSI}	—	10	μA
Output high voltage, I _{OH} = −2 mA	V _{OH}	2.4	—	V
Output low voltage, I _{OL} = 2 mA	V _{OL}	—	0.4	V
Capacitance, V _{in} = 0 V, f = 1 MHz ² (excludes \overline{TS} , \overline{ABB} , \overline{DBB} , and \overline{ARTRY})	C _{in}	—	10.0	pF
Capacitance, V _{in} = 0 V, f = 1 MHz ² (for \overline{TS} , \overline{ABB} , \overline{DBB} , and \overline{ARTRY})	C _{in}	—	15.0	pF
Output impedance Normal mode (DRV_MOD[0–1] = 01) Strong mode (DRV_MOD[0–1] = 10) Herculean mode (DRV_MOD[0–1] = 11)	Z _o	56 42 30	84 57 30	Ω

Notes:

1. Excludes test signals (LSSD_MODE, L1_TSTCLK, L2_TSTCLK, and JTAG signals).
2. Capacitance values are guaranteed by design and characterization, and are not tested.
3. Output impedance is guaranteed by design and is not tested. Refer to IBIS simulation models for output impedance values based on Vdd and OVdd tolerances used in system.

Table 5 provides the power consumption for the 604e.

Table 5. Power Consumption

CPU Clock: SYSCLK	Processor Core Frequency			Unit
	266 MHz	300 MHz	333 MHz	
Full-On Mode				
Typical	6.0	6.8	7.5	W
Maximum	10.6	12.0	13.4	W
Nap Mode				
Typical	TBD	TBD	TBD	W
Maximum	0.78	0.80	0.82	W

Notes:

1. These values apply for all valid PLL_CFG[0–3] settings and do not include output driver power (OVdd) or analog supply power (AVdd). OVdd power is system dependent but is typically $\leq 10\%$ of Vdd. Worst-case AVdd = 15 mW.
2. Typical power is an average value estimated at Vdd = AVdd = 1.9 V, OVdd = 3.3 V, T_j = 25 °C in a system executing typical applications and benchmark sequences. Typical power numbers should be used in planning for proper thermal management.
3. Maximum power is estimated at Vdd = AVdd = 2.0 V, OVdd = 3.465 V, T_j = 0 °C using a worst-case instruction mix. These values should be used for power supply design.
4. Nap mode power consumption is estimated, and assumes no snoop activity.

1.4.2 AC Electrical Characteristics

This section provides the AC electrical characteristics for the 604e. These specifications are for 266, 300, and 333 MHz processor core frequencies. The processor core frequency is determined by the bus (SYSCLK) frequency and the settings of the PLL_CFG[0–3] signals. All timings are specified relative to the rising edge of SYSCLK.

1.4.2.1 Clock AC Specifications

Table 6 provides the clock AC timing specifications as defined in Figure 1.

Table 6. Clock AC Timing Specifications

Vdd = AVdd = 1.9 ±100 mV dc, OVdd = 3.3 ± 5% V dc, GND = 0 V dc, 0 ≤ T_j ≤ 105 °C

Num	Characteristic	266 MHz		300 MHz		333 MHz		Unit	Notes
		Min	Max	Min	Max	Min	Max		
	Processor frequency	250	266	266	300	300	333	MHz	1
	VCO frequency	500	532	532	600	600	666	MHz	1
	SYSCLK frequency	35.7	100	38	100	42.9	100	MHz	1, 6
1	SYSCLK cycle time	10	35	10	28	10	25	ns	
2, 3	SYSCLK rise and fall time	1.0	2.0	1.0	2.0	1.0	2.0	ns	2

Table 6. Clock AC Timing Specifications (Continued)

Vdd = AVdd = 1.9 ±100 mV dc, OVdd = 3.3 ± 5% V dc, GND = 0 V dc, 0 ≤ Tj ≤ 105 °C

Num	Characteristic	266 MHz		300 MHz		333 MHz		Unit	Notes
		Min	Max	Min	Max	Min	Max		
4	SYSCCLK duty cycle measured at 0.9 V	40	60	40	60	40	60	%	3
	SYSCCLK jitter	—	±150	—	±150	—	±150	ps	4
	604e internal PLL relock time	—	100	—	100	—	100	μs	3, 5

Notes:

- Caution:** The SYSCCLK frequency and PLL_CFG[0–3] settings must be chosen such that the resulting SYSCCLK (bus) frequency, CPU (core) frequency, and PLL (VCO) frequency do not exceed their respective maximum or minimum operating frequencies. Refer to the PLL_CFG[0–3] signal description in Section 1.8, “System Design Information,” for valid PLL_CFG[0–3] settings, and to Section 1.9, “Ordering Information,” for available frequencies and part numbers.
- Rise and fall times for the SYSCCLK input are measured from 0.4 V to 1.8 V.
- Timing is guaranteed by design and characterization, and is not tested.
- Cycle-to-cycle jitter, and is guaranteed by design.
- PLL-relock time is the maximum time required for PLL lock after a stable Vdd, OVdd, AVdd, and SYSCCLK are reached during the power-on reset sequence. Also note that HRESET must be held asserted for a minimum of 255 bus clocks after the PLL-relock time (100 μs) during the power-on reset sequence.
- 604e processors are tested at the maximum SYSCCLK frequencies shown in the AC timing specifications. It is possible to attain higher SYSCCLK frequencies through proper system design.

Figure 1 provides the SYSCCLK input timing diagram.

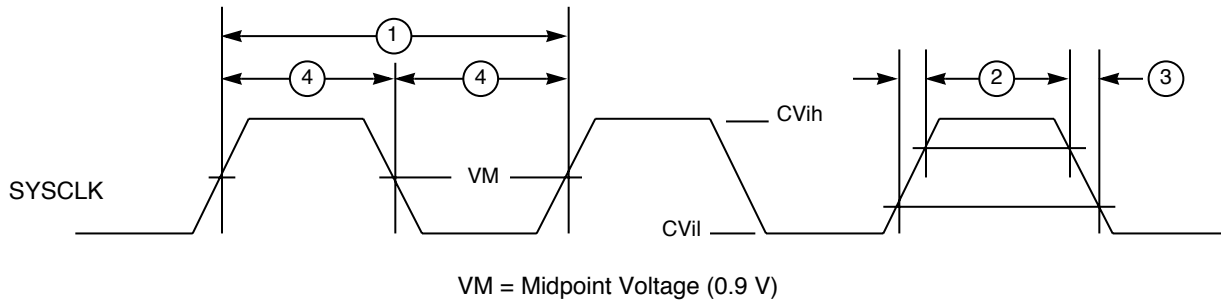

Figure 1. SYSCCLK Input Timing Diagram

1.4.2.2 Input AC Specifications

Table 7 provides the input AC timing specifications for the 604e as defined in Figure 2. These specifications are for 266, 300, and 333 MHz processor core frequencies.

Table 7. Input AC Timing Specifications¹

Vdd = AVdd = 1.9 ±100 mV dc, OVdd = 3.3 ± 5% V dc, GND = 0 V dc, 0 ≤ Tj ≤ 105 °C

Num	Characteristic	266, 300, 333 MHz		Unit	Notes
		Min	Max		
7a	ARTRY, SHD, ABB, TS, XATS, AACK, BG, DRTRY, TA, DBG, DBB, TEA, DBDIS, and DBWO valid to SYSCLK (input setup)	3.50	—	ns	
7b	All other inputs valid to SYSCLK (input setup) ⁷	2.50	—	ns	2
8	SYSCLK to all inputs invalid (input hold)	-0.5	—	ns	
9	Mode select input valid to HRESET (input setup for DRTRY)	8 * t _{sysclk}	—	ns	3, 4, 5, 6
10	HRESET to mode select input invalid (input hold for DRTRY)	-0.5	—	ns	3, 4, 5, 6

Notes:

1. Input specifications are measured from the TTL level (0.8 or 2.0 V) of the signal in question to the 0.9 V of the rising edge of the input SYSCLK. Input and output timings are measured at the pin (see Figure 2).
2. All other input signals include the following signals—all inputs except ARTRY, SHD, ABB, TS, XATS, AACK, BG, DRTRY, TA, DBG, DBB, DBWO, DBDIS, TEA, and JTAG inputs.
3. The setup and hold time is with respect to the rising edge of HRESET (see Figure 3).
4. t_{sysclk} is the period of the external clock (SYSCLK) in nanoseconds.
5. These values are guaranteed by design, and are not tested.
6. Note this is for configuration of the fast-L2 mode and the no-DRTRY mode.
7. Setup time is extended by 0.5 ns for these signals when Hysteresis On mode is enabled.

Figure 2 provides the input timing diagram for the 604e.

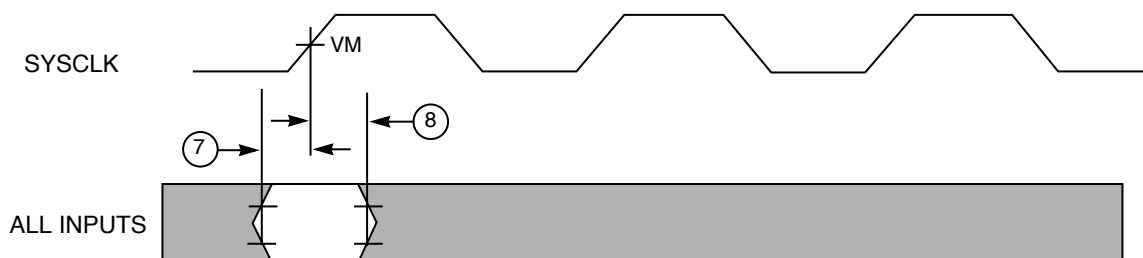

VM = Midpoint Voltage (0.9 V)

Figure 2. Input Timing Diagram

Figure 3 provides the mode select input timing diagram for the 604e.

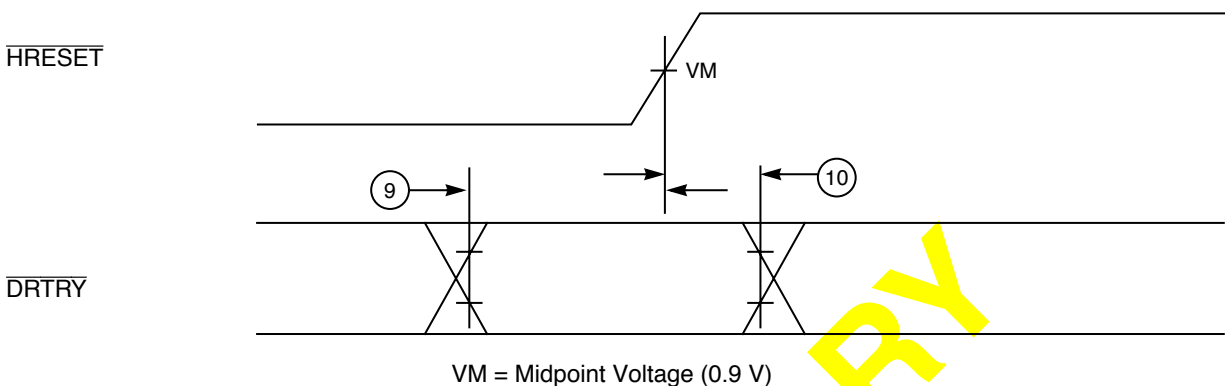

Figure 3. Mode Select Input Timing Diagram

1.4.2.3 Output AC Specifications

The output specifications of the 604e for both driving high and driving low depend on the capacitive loading on each output and the drive capability enabled for that output. Additionally, the timing specifications for outputs driving low also depend on the voltage swing required to drive to 0.4V. Table 8 provides the output AC timing specifications for a 5pF, 50 Ω transmission line load. In order to derive the actual timing specifications for a given set of conditions, it is recommended that IBIS simulation models be used. The IBIS models are currently based on device simulation data. Compatibility mode specifications are provided to support PID9q-604e use in existing designs. Contact the local Motorola or IBM sales office for information on the availability of these models.

Table 8 provides the output AC timing specifications for the 604e (refer to Figure 4).

Table 8. Output AC Timing Specifications¹

Vdd = AVdd = 1.9 ±100 mV dc, OVdd = 3.3 ± 5% V dc, GND = 0 V dc, 0 ≤ Tj ≤ 105 °C, drive mode [11]⁶

Num	Characteristic	266, 300, 333 MHz			Unit	Notes
		Min	Max	Compatibility Mode		
11	SYSCLK to output driven (output enable time)	0.75	—	0.75 Min	ns	2, 5
12	SYSCLK to \overline{TS} , \overline{XATS} , \overline{ARTRY} , \overline{SHD} , \overline{ABB} and \overline{DBB} output valid	—	3.75	4.75 Max	ns	5
13	SYSCLK to all other signals output valid	—	4.75	5.75 Max	ns	5
14	SYSCLK to output invalid (output hold)	0.0		0.5 Min	ns	2, 5
15	SYSCLK to output high impedance (all signals except \overline{ARTRY} , \overline{SHD} , \overline{ABB} , \overline{DBB} , \overline{TS} , and \overline{XATS})	—	3.4	4.4 Max	ns	5
16	SYSCLK to output high impedance \overline{TS} , \overline{XATS}	—	3.4	4.4 Max	ns	5
17	SYSCLK to \overline{ABB} and \overline{DBB} high impedance after precharge	—	1.0* t _{sysclk}	1.0* t _{sysclk} Max	ns	4
18	SYSCLK to \overline{ARTRY} and \overline{SHD} high impedance before precharge	—	3.4	4.4 Max	ns	5

Table 8. Output AC Timing Specifications¹ (Continued)

V_{dd} = AV_{dd} = 1.9 ± 100 mV dc, OV_{dd} = 3.3 ± 5% V dc, GND = 0 V dc, 0 ≤ T_j ≤ 105 °C, drive mode [11]⁶

Num	Characteristic	266, 300, 333 MHz			Unit	Notes
		Min	Max	Compatibility Mode		
19	SYSCLK to $\overline{\text{ARTRY}}$, and $\overline{\text{SHD}}$ precharge enable	0.5* t _{sysclk} + 0.75	—	0.5* t _{sysclk} + 0.75 Max	ns	4
20	Maximum delay to $\overline{\text{ARTRY}}$ and $\overline{\text{SHD}}$ precharge	—	1.5* t _{sysclk}	1.5* t _{sysclk} Max	ns	4
21	SYSCLK to $\overline{\text{ARTRY}}$ and $\overline{\text{SHD}}$ high impedance after precharge	—	2.0* t _{sysclk}	2.0* t _{sysclk} Max	ns	4
	Rise time ($\overline{\text{ARTRY}}$, $\overline{\text{SHD}}$, $\overline{\text{ABB}}$, $\overline{\text{DBB}}$, $\overline{\text{TS}}$, and $\overline{\text{XATS}}$)	1.0	1.0	1.0	ns	3
	Rise time (all signals except $\overline{\text{ARTRY}}$, $\overline{\text{SHD}}$, $\overline{\text{ABB}}$, $\overline{\text{DBB}}$, $\overline{\text{TS}}$, and $\overline{\text{XATS}}$)	1.0	1.0	1.0	ns	3
	Fall time ($\overline{\text{ARTRY}}$, $\overline{\text{SHD}}$, $\overline{\text{ABB}}$, $\overline{\text{DBB}}$, $\overline{\text{TS}}$, and $\overline{\text{XATS}}$)	1.0	1.0	1.0	ns	3
	Fall time (all signals except $\overline{\text{ARTRY}}$, $\overline{\text{SHD}}$, $\overline{\text{ABB}}$, $\overline{\text{DBB}}$, $\overline{\text{TS}}$, and $\overline{\text{XATS}}$)	1.0	1.0	1.0	ns	3

Notes:

1. All output specifications are measured from the 0.9 V level of the rising edge of SYSCLK to the TTL level (0.5 V or 2.0 V) of the signal in question. Both input and output timings are measured at the pin (see Figure 4).
2. All AC timing is based on a 5pF, 50 Ω transmission line load
3. These specifications are nominal values
4. t_{sysclk} is the period of the external bus clock (SYSCLK) in nanoseconds (ns). When the unit is given as t_{sysclk} the numbers given in the table must be multiplied by the period of SYSCLK to compute the actual time duration (in nanoseconds) of the parameter in question.
5. These specifications are nominal values for Fast Out mode; refer to Section 1.8.2, "Input and Output Signal Mode Selection" for signal configuration to enable Fast Out mode. The PID9q-604e is tested in Fast Out mode. Compatibility mode is guaranteed by design and is not tested.
6. To operate in accordance with these specifications, the drive mode signals must be configured with DRVMOD0 = high, and DRVMOD1 = high.

Figure 4 provides the output timing diagram for the 604e.

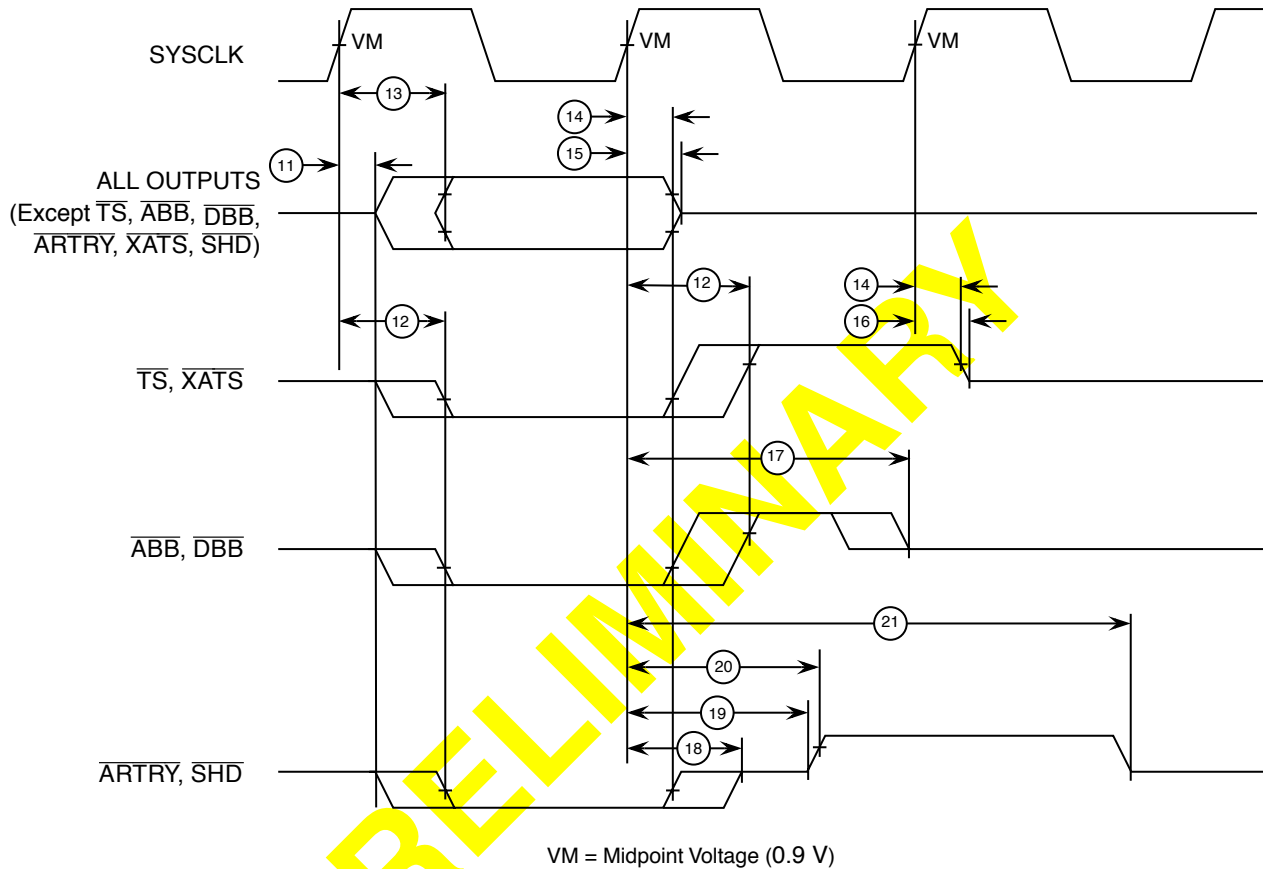

Figure 4. Output Timing Diagram

1.4.3 JTAG AC Timing Specifications

Table 9 provides the JTAG AC timing specifications.

Table 9. JTAG AC Timing Specifications (Independent of SYSCLK)

Vdd = AVdd = 1.9 ±100 mV dc, OVdd = 3.3 ± 5%, GND = 0 V dc, CL = 5 pF, 0 ≤ Tj ≤ 105 °C

Num	Characteristic	Min	Max	Unit	Notes
	TCK frequency of operation	0	16	MHz	
1	TCK cycle time	62.5	—	ns	
2	TCK clock pulse width measured at 0.9 V	25	—	ns	
3	TCK rise and fall times	0	3	ns	
4	$\overline{\text{TRST}}$ setup time to TCK rising edge	13	—	ns	1
5	$\overline{\text{TRST}}$ assert time	40	—	ns	
6	Boundary-scan input data setup time	0	—	ns	2
7	Boundary-scan input data hold time	27	—	ns	2

Table 9. JTAG AC Timing Specifications (Independent of SYSCLK) (Continued)

V_{dd} = AV_{dd} = 1.9 ±100 mV dc, OV_{dd} = 3.3 ± 5%, GND = 0 V dc, C_L = 5 pF, 0 ≤ T_j ≤ 105 °C

Num	Characteristic	Min	Max	Unit	Notes
8	TCK to output data valid	4	25	ns	3
9	TCK to output high impedance	3	24	ns	3
10	TMS, TDI data setup time	0	—	ns	
11	TMS, TDI data hold time	25	—	ns	
12	TCK to TDO data valid	4	24	ns	
13	TCK to TDO high impedance	3	15	ns	

Notes:

1. $\overline{\text{TRST}}$ is an asynchronous signal. The setup time is for test purposes only.
2. Non-test signal input timing with respect to TCK.
3. Non-test signal output timing with respect to TCK.

Figure 5 provides the JTAG clock input timing diagram.

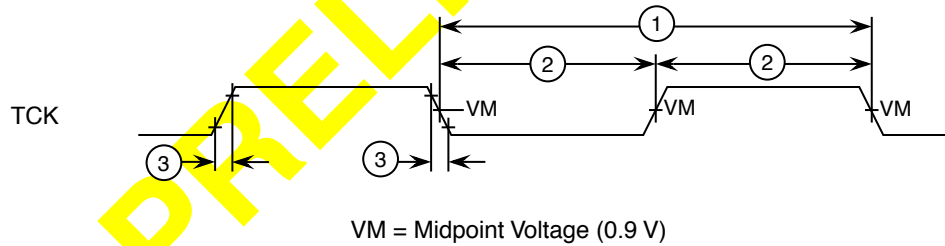

Figure 5. Clock Input Timing Diagram

Figure 6 provides the $\overline{\text{TRST}}$ timing diagram.

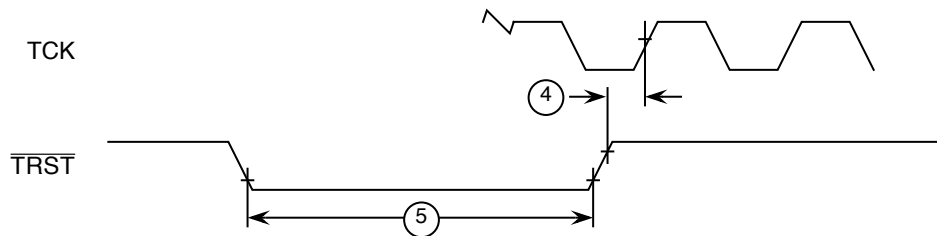

Figure 6. $\overline{\text{TRST}}$ Timing Diagram

Figure 7 provides the boundary-scan timing diagram.

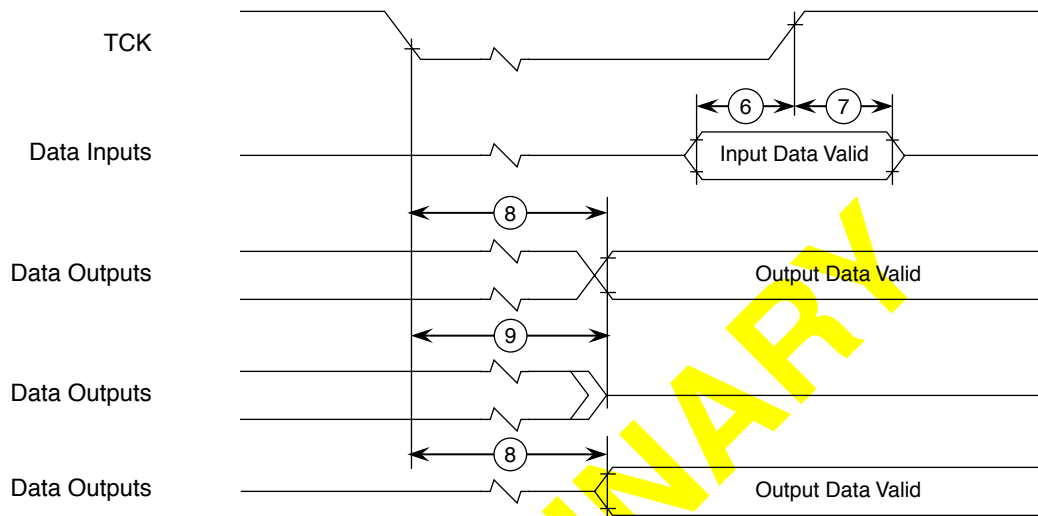

Figure 7. Boundary-Scan Timing Diagram

Figure 8 provides the test access port timing diagram.

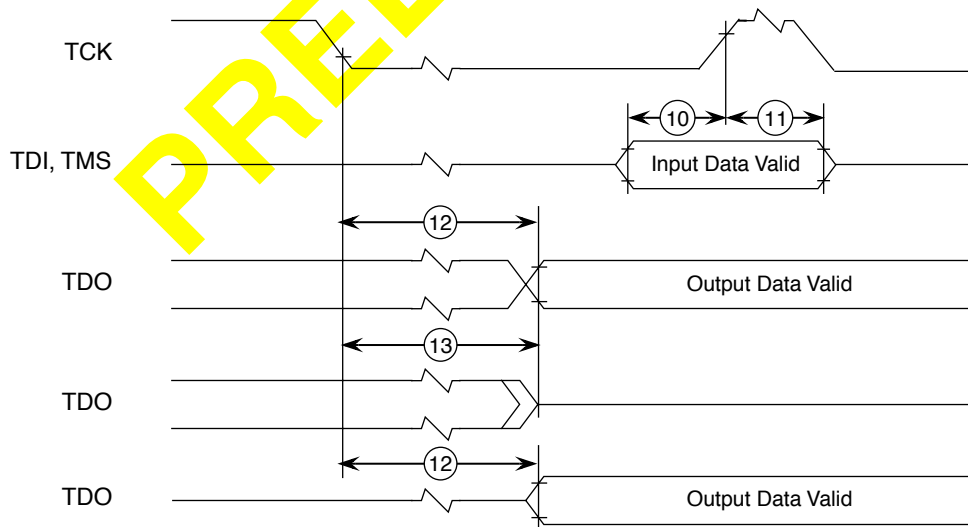
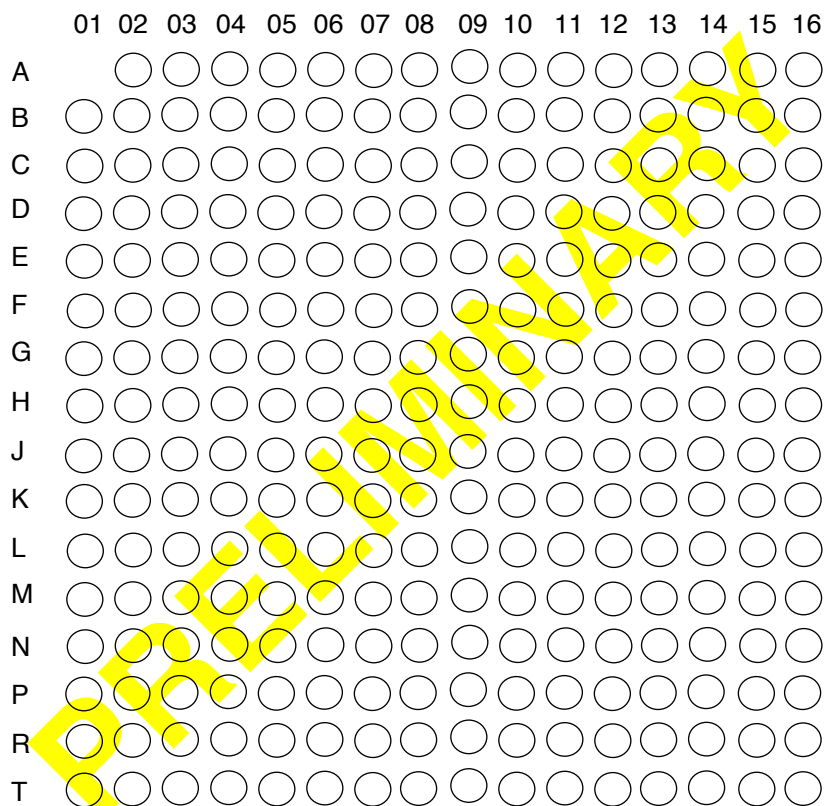

Figure 8. Test Access Port Timing Diagram

1.5 Pin Assignments

Motorola and IBM both offer a ceramic ball grid array (CBGA) package. Both IBM and Motorola CBGA packages have identical pinouts. Figure 9 (in part A) shows the pinout of the CBGA package as viewed from the top surface. Part B shows the side profile of the CBGA package to indicate the direction of the top surface view.

Part A



Not to Scale

Part B

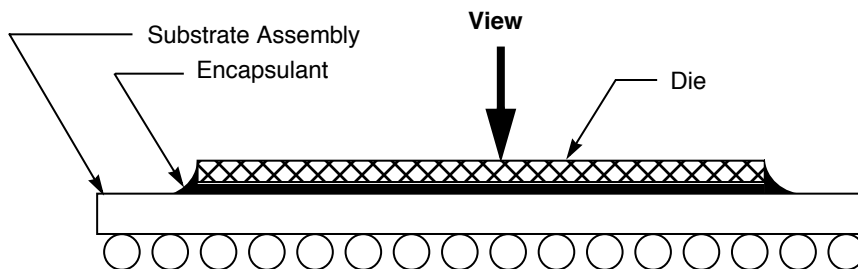

Figure 9. Pinout of the CBGA Package as Viewed from the Top Surface

1.6 Pinout Listings

Table 10 provides the pinout listing for the 604e CBGA package.

Table 10. Pinout Listing for the CBGA Package

Signal Name	Pin Number	Active	I/O
A[0–31]	C16, E04, D13, F02, D14, G01, D15, E02, D16, D04, E13, GO2, E15, H01, E16, H02, F13, J01, F14, J02, F15, H03, F16, F04, G13, K01, G15, K02, H16, M01, J15, P01	High	I/O
$\overline{\text{AACK}}$	L02	Low	Input
$\overline{\text{ABB}}$	K04	Low	I/O
AP[0–3]	C01, B04, B03, B02	High	I/O
$\overline{\text{APE}}$	A04	Low	Output
ARRAY_WR ¹	B07	Low	Input
$\overline{\text{ARTRY}}$	J04	Low	I/O
AVDD	A10	—	—
$\overline{\text{BG}}$	L01	Low	Input
BR	B06	Low	Output
$\overline{\text{CI}}$	E01	Low	Output
CKSTP_IN	D08	Low	Input
$\overline{\text{CKSTP_OUT}}$	A06	Low	Output
CLK_OUT	D07	—	Output
CSE[0–1]	B01, B05	High	Output
DBB	J14	Low	I/O
$\overline{\text{DBG}}$	N01	Low	Input
$\overline{\text{DBDIS}}$	H15	Low	Input
$\overline{\text{DBW}\overline{\text{O}}}$	G04	Low	Input
DH[0–31]	P14, T16, R15, T15, R13, R12, P11, N11, R11, T12, T11, R10, P09, N09, T10, R09, T09, P08, N08, R08, T08, N07, R07, T07, P06, N06, R06, T06, R05, N05, T05, T04	High	I/O
DL[0–31]	K13, K15, K16, L16, L15, L13, L14, M16, M15, M13, N16, N15, N13, N14, P16, P15, R16, R14, T14, N10, P13, N12, T13, P03, N03, N04, R03, T01, T02, P04, T03, R04	High	I/O
DP[0–7]	M02, L03, N02, L04, R01, P02, M04, R02	High	I/O
$\overline{\text{DPE}}$	A05	Low	Output
$\overline{\text{DRTRY}}$	G16	Low	Input
DRVMOD ³	D05	High	Input
DRVMOD ¹ ³	C03	High	Input
GBL	F01	Low	I/O

Table 10. Pinout Listing for the CBGA Package (Continued)

Signal Name	Pin Number	Active	I/O
GND	C05, C12, E03, E06, E08, E09, E11, E14, F05, F07, F10, F12, G06, G08, G09, G11, H05, H07, H10, H12, J05, J07, J10, J12, K06, K08, K09, K11, L05, L07, L10, L12, M03, M06, M08, M09, M11, M14, P05, P12	—	—
HALTED	B08	High	Output
$\overline{\text{HRESET}}$	A07	Low	Input
$\overline{\text{INT}}$	B15	Low	Input
L1_TSTCLK ¹	D11	Low	Input
L2_INT	D06	High	Input
L2_TSTCLK ¹	D12	Low	Input
$\overline{\text{LSSD_MODE}}$ ¹	B10	Low	Input
MCP	C13	Low	Input
OVDD	C07, E05, E07, E10, E12, G03, G05, G12, G14, K03, K05, K12, K14, M05, M07, M10, M12, P07, P10	—	—
PLL_CFG[0–3]	A08, B09, A09, D09	High	Input
RSRV	D01	Low	Output
RUN	C08	High	Input
$\overline{\text{SHD}}$	H04	Low	I/O
$\overline{\text{SMI}}$	A16	Low	Input
$\overline{\text{SRESET}}$	B14	Low	Input
SYSClk	C09	—	Input
$\overline{\text{TA}}$	H14	Low	Input
TBEN	C02	High	Input
$\overline{\text{TBST}}$	A14	Low	I/O
TC[0–2]	A02, A03, C06	High	Output
TCK	C11	High	Input
TDI	A11	High	Input
TDO	A12	High	Output
$\overline{\text{TEA}}$	H13	Low	Input
TMS	B11	High	Input
$\overline{\text{TRST}}$	C10	Low	Input
$\overline{\text{TS}}$	J13	Low	I/O
TSIZ[0–2]	A13, D10, B12	High	I/O
TT[0–4]	B13, A15, B16, C14, C15	High	I/O

Table 10. Pinout Listing for the CBGA Package (Continued)

Signal Name	Pin Number	Active	I/O
WT	D02	Low	Output
VDD	F06, F08, F09, F11, G07, G10, H06, H08, H09, H11, J06, J08, J09, J11, K07, K10, L06, L08, L09, L11	—	—
VOLTDETGND ²	F03		
XATS	J16	Low	I/O

Notes:

1. These are test signals for factory use only and must be pulled up to Vdd for normal machine operation.
2. NC (no-connect) in the 604; internally tied to GND in the 604e CBGA package to indicate to the power supply that a low-voltage processor is present.
3. To operate in accordance with these specifications, the drive mode signals must be configured with DRVMOD0 = high, and DRVMOD1 = high.

1.7 Package Description

The package parameters for the 604e are provided in the following list. The package type is 21 mm, 256-lead ceramic ball grid array (CBGA).

Package outline	21 x 21 mm
Interconnects	255
Pitch	1.27 mm (50 mil)
Maximum module height	3.30 mm
Ball diameter	0.89 mm (35 mil)

1.7.0.1 Mechanical Dimensions of the CBGA Package

Figure 10 provides the mechanical dimensions and bottom surface nomenclature of the IBM and Motorola CBGA package.

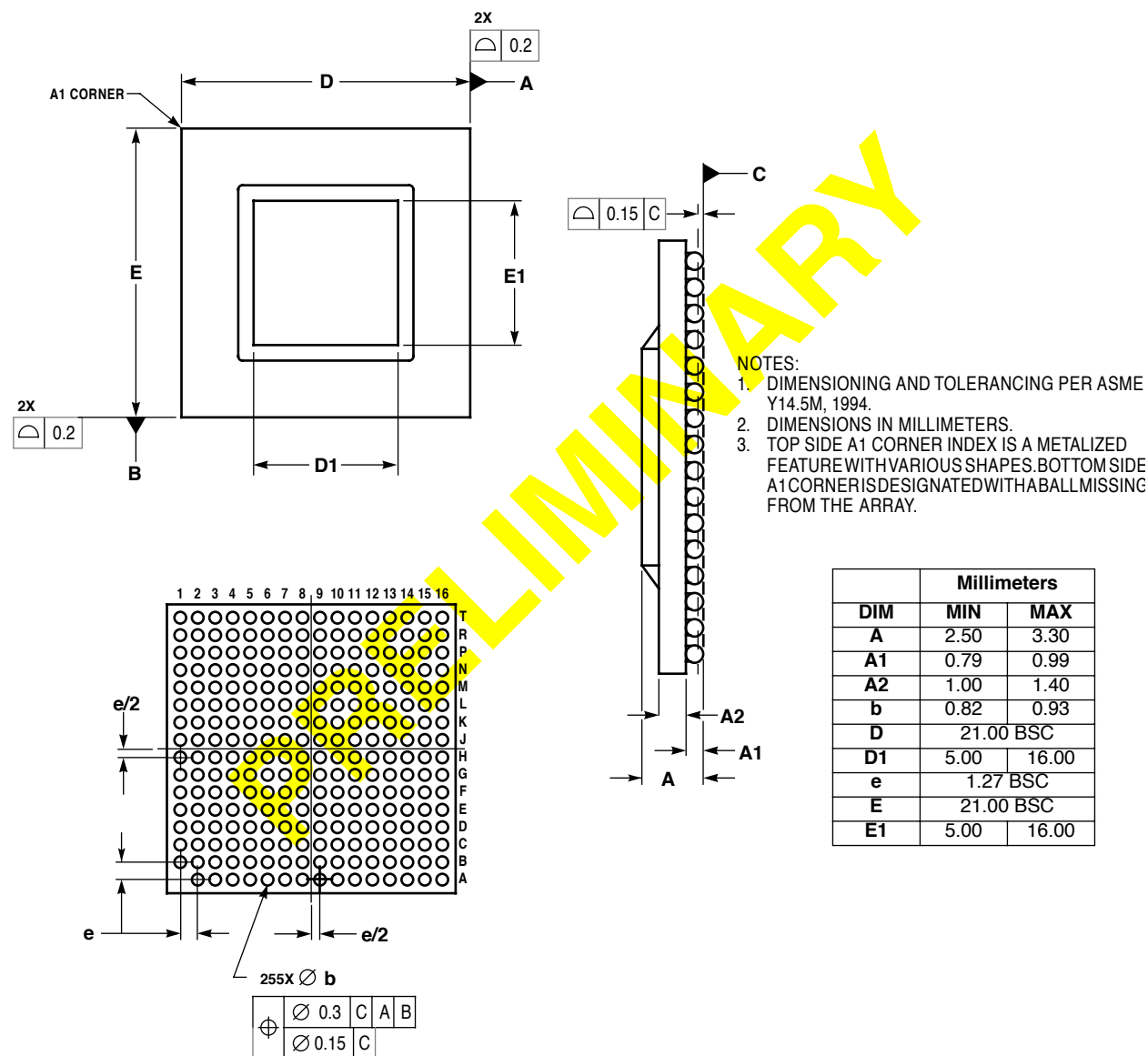

Figure 10. Mechanical Dimensions and Bottom Surface Nomenclature of the CBGA Package

1.8 System Design Information

This section provides electrical and thermal design recommendations for successful application of the 604e.

1.8.1 PLL Configuration

The 604e PLL is configured by the PLL_CFG[0–3] signals. For a given SYSCLK (bus) frequency, the PLL configuration signals set the internal CPU and VCO frequency of operation. The PLL configuration for the 604e is shown in Table 11 for nominal frequencies.

Table 11. PLL Configuration

PLL_CFG [0–3]		CPU/ SYSCLK Ratio	VCO Multiplier	CPU Frequency in MHz (VCO Frequency in MHz)							
Bin	Dec			Bus 25 MHz	Bus 33.3 MHz	Bus 40 MHz	Bus 50 MHz	Bus 60 MHz	Bus 66.6 MHz	Bus 83.3 MHz	Bus 100 MHz
0000	0	1:1	x2	–	–	–	–	–	–	–	–
0001	1	1:1	x8	–	–	40 (320)	50 (400)	60 (480)	66 (533)	83.3 (666)	–
1100	12	1.5:1	x2	–	–	–	–	–	–	–	–
0100	4	2:1	x2	–	–	–	–	–	–	–	200 (400)
0110	6	2.5:1	x2	–	–	–	–	–	–	208 (416)	250 (500)
1000	8	3:1	x2	–	–	–	–	–	200 (400)	250 (500)	300 (600)
1110	14	3.5:1	x2	–	–	–	–	210 (420)	233 (466)	292 (584)	350 (700)
1010	10	4:1	x2	–	–	–	200 (400)	240 (480)	266 (532)	333 (666)	–
0111	7	4.5:1	x2	–	–	–	225 (450)	270 (540)	300 (600)	–	–
1011	11	5:1	x2	–	–	200 (400)	250 (500)	300 (600)	333 (666)	–	–
1001	9	5.5:1	x2	–	–	220 (440)	275 (550)	330 (660)	–	–	–
1101	13	6:1	x2	–	200 (400)	240 (480)	300 (600)	–	–	–	–
0101	5	6.5:1	x2	–	216 (433)	260 (520)	325 (650)	–	–	–	–
0010	2	7:1	x2	–	233 (466)	280 (560)	350 (700)	–	–	–	–
0011	3	PLL bypass									
1111	15	Clock off									

Notes:

1. Some PLL configurations may select bus, CPU, or VCO frequencies which are not supported; see Section 1.4.2.2, “Input AC Specifications,” for valid SYSCLK and VCO frequencies.
2. In PLL-bypass mode, the SYSCLK input signal clocks the internal processor directly, the PLL is disabled, and the bus mode is set for 1:1 mode operation. This mode is intended for factory use only.
Note: The AC timing specifications given in this document do not apply in PLL-bypass mode.

1.8.2 Input and Output Signal Mode Selection

The PID9q-604e's input buffers can be configured through the connection of the ARRAY_WR signal to provide input hysteresis and enable the CLKOUT signal. If the ARRAY_WR signal is connected to OVdd, the PID9q-604e will select the Hysteresis Off input buffer threshold mode, and the CLKOUT signal is enabled, which is the default mode for this specification. When Hysteresis OFF mode is selected the VM is 0.9V.

If ARRAY_WR is connected to GND, Hysteresis On mode is selected, and the CLKOUT signal is placed in a high impedance state. When Hysteresis On mode is selected, the VM is 1.3V, and the input transition points are 1.1V for V_{IL} and 1.5V for V_{IH} . Hysteresis On mode provides for greater noise immunity on inputs, and the input hold time requirement for Low to High transitions is increased.

When the ARRAY_WR signal is connected to the $\overline{\text{HRESET}}$ signal, Hysteresis On mode is selected, and the CLKOUT signal is enabled. If the ARRAY_WR signal is connected to an inverted $\overline{\text{HRESET}}$ signal, Hysteresis Off mode is selected, and the CLKOUT signal is placed in a high impedance state.

Table 12 below shows the configuration of the ARRAY_WR signal to select input signal hysteresis and enable the CLKOUT signal.

Table 12. Input Signal Hysteresis and CLKOUT Signal Configuration

Signal	Connected to	Mode Selected	Notes
ARRAY_WR	OVdd	Hysteresis Off CLKOUT Enabled	1
	GND	Hysteresis On CLKOUT high impedance	
	$\overline{\text{HRESET}}$ signal	Hysteresis On CLKOUT Enabled	
	HRESET	Hysteresis Off CLKOUT high impedance	2

Notes:

1. Default Mode
2. HRESET is the inverted state of the $\overline{\text{HRESET}}$ signal

The PID9q-604e implements a Fast Out output mode which allows increased system bus frequencies. The PID9q-604e can be configured for Fast Out mode by connecting the L2_TSTCLK signal to GND or the $\overline{\text{HRESET}}$ signal. When Fast Out mode is enabled, the output valid and output hold times are reduced. If the L2_TSTCLK signal is connected to OVdd or to an inverted $\overline{\text{HRESET}}$, compatibility mode is selected.

Table 13 describes the configuration of the L2_TSTCLK signal to select Fast Out or compatibility output modes.

Table 13. FastOut/Compatibility Output Signal Configuration

Signal	Connected to	Mode Selected	Notes
L2_TSTCLK	OVdd	Compatibility	
	GND	FastOut	1
	HRESET	FastOut	
	HRESET	Compatibility	2

Notes:

1. Default Mode
- 2.HRESET is the inverse state of the $\overline{\text{HRESET}}$ signal

1.8.3 PLL Power Supply Filtering

The AVdd power signal is provided on the 604e to provide power to the clock generation phase-locked loop. To ensure stability of the internal clock, the power supplied to the AVdd input signal should be filtered using a circuit similar to the one shown in Figure 11. The circuit should be placed as close as possible to the AVdd pin to ensure it filters out as much noise as possible.

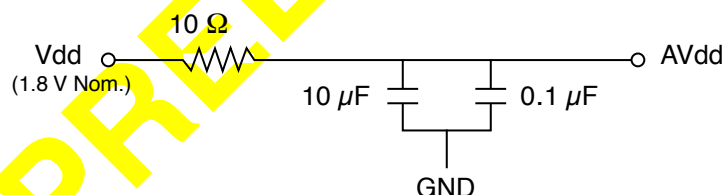

Figure 11. PLL Power Supply Filter Circuit

1.8.4 Decoupling Recommendations

Due to the 604e's large address and data buses, and high operating frequencies, the 604e can generate transient power surges and high frequency noise in its power supply, especially while driving large capacitive loads. This noise must be prevented from reaching other components in the 604e system, and the 604e itself requires a clean, tightly regulated source of power. Therefore, it is strongly recommended that the system designer place at least one decoupling capacitor with a low ESR (effective series resistance) rating at each Vdd and OVdd pin of the 604e.

These capacitors should range in value from 220 pF to 10 μF to provide both high- and low-frequency filtering, and should be placed as close as possible to their associated Vdd pin. Surface-mount tantalum or ceramic devices are preferred. It is also recommended that these decoupling capacitors receive their power from Vdd and GND power planes in the PCB, utilizing short traces to minimize inductance in the traces. Power and ground connections must be made to all external Vdd and GND pins of the 604e.

1.8.5 Connection Recommendations

To ensure reliable operation, it is recommended to connect unused inputs to an appropriate signal level. Unused active low inputs should be tied to Vdd. Unused active high inputs should be connected to GND.

1.8.6 Thermal Management Information

This section provides thermal management information for the ceramic ball grid array (CBGA) package for air-cooled applications. Proper thermal control design is primarily dependent upon the system-level design—the heat sink, airflow and thermal interface material. To reduce the die-junction temperature, heat sinks may be attached to the package by several methods—adhesive, spring clip to holes in the printed-circuit board or package, and mounting clip and screw assembly; see Figure 12. This spring force should not exceed 5.5 pounds of force.

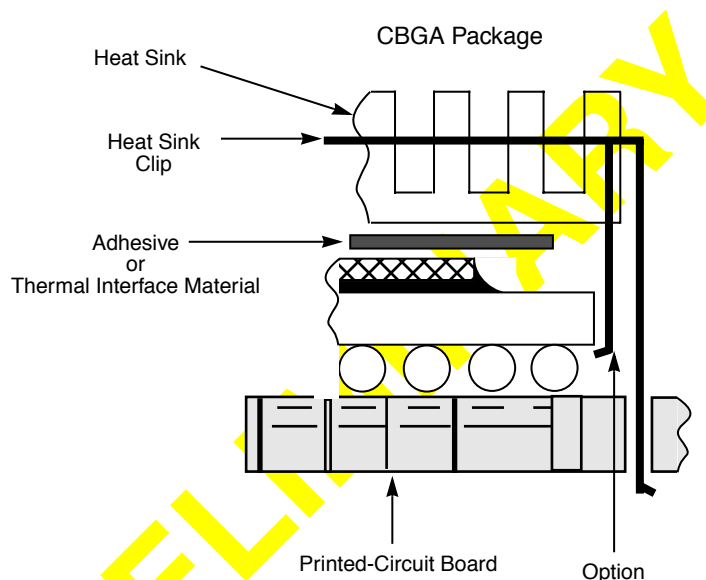

Figure 12. Package Exploded Cross-Sectional View with Several Heat Sink Options

The board designer can choose between several types of heat sinks to place on the 604e. There are several commercially-available heat sinks for the 604e provided by the following vendors:

Thermalloy

2021 W. Valley View Lane

214-243-4321

P.O. Box 810839

Dallas, TX 75731

International Electronic Research Corporation (IERC)

135 W. Magnolia Blvd.

Burbank, CA 91502

818-842-7277

Aavid Engineering

603-528-3400

One Kool Path

Laconic, NH 03247-0440

Wakefield Engineering

617-245-5900

60 Audubon Rd.

Wakefield, MA 01880

Ultimately, the final selection of an appropriate heat sink for the 604e depends on many factors, such as thermal performance at a given air velocity, spatial volume, mass, attachment method, assembly, and cost.

1.8.6.1 Internal Package Conduction Resistance

For the exposed-die packaging technology, shown in Table 14, the intrinsic conduction thermal resistance paths are as follows:

- The die junction-to-case thermal resistance
- The die junction-to-lead thermal resistance

Table 14. Package Thermal Resistance

Thermal Metric	CBGA
Junction-to-top of die thermal resistance	0.03 °C/W
Junction-to-lead (ball) thermal resistance	2.2 °C/W

Figure 13 depicts the primary heat transfer path for a package with an attached heat sink mounted to a printed-circuit board.

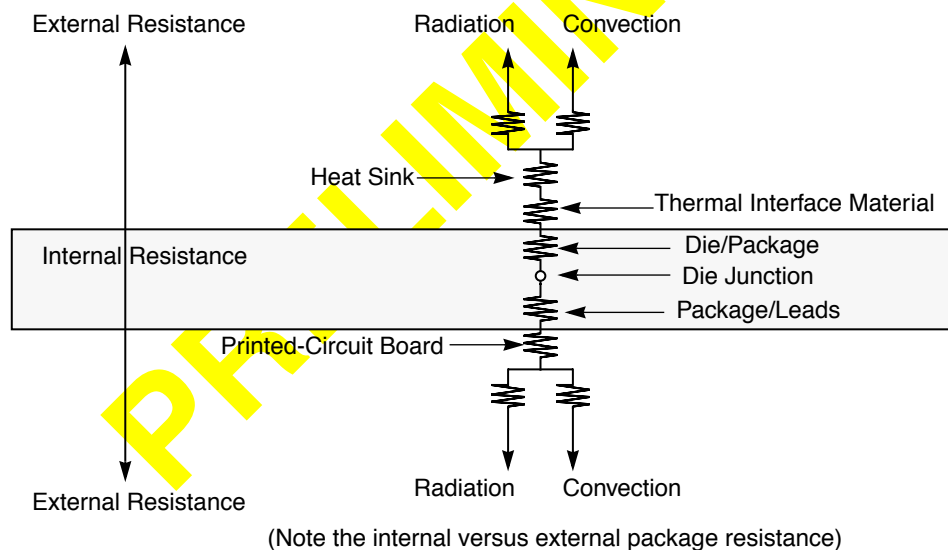

Figure 13. C4 Package with Heat Sink Mounted to a Printed-Circuit Board

Heat generated on the active side (ball) of the chip is conducted through the silicon, then through the heat sink attach material (or thermal interface material), and finally to the heat sink where it is removed by forced-air convection.

Since the silicon thermal resistance is quite small, for a first-order analysis, the temperature drop in the silicon may be neglected. Thus, the heat sink attach material and the heat sink conduction/conductive thermal resistances are the dominant terms. The following section provides a thermal management example for the 604e using one of the commercially available heat sinks.

1.8.6.2 Thermal Management Example

For preliminary heat sink sizing, the die-junction temperature can be expressed as follows:

$$T_j = T_a + T_r + (R_{\theta_{jc}} + R_a + R_{sa}) * Q$$

Where:

T_j is the die-junction temperature

T_a is the inlet cabinet ambient temperature

T_r is the air temperature rise within the system cabinet

$R_{\theta_{jc}}$ is the die-junction-to-top of die thermal resistance of the device

R_a is the thermal resistance of the thermal interface material (thermal grease or thermal compound)

R_{sa} is the heat sink-to-ambient thermal resistance

Q is the power consumed by the device

Typical die-junction temperatures (T_j) should be maintained less than 105 °C. The temperature of the air cooling the component greatly depends upon the ambient inlet air temperature and the air temperature rise within the computer cabinet. A computer cabinet inlet-air temperature (T_a) may range from 30 to 40 °C. The air temperature rise within a cabinet (T_r) may be in the range of 5 to 10 °C. The thermal resistance of the interface material (R_a) is typically about 1 °C/W. Assuming a T_a of 30 °C, a T_r of 5 °C, and a power consumption (Q) of 7.5 watts, the following expression for T_j is obtained:

$$\text{Junction temperature: } T_j = 30 \text{ °C} + 5 \text{ °C} + (0.03 \text{ °C/W} + 1.0 \text{ °C/W} + R_{sa}) * 7.5 \text{ W}$$

For a Thermalloy heat sink #2333B, the heat sink-to-ambient thermal resistance (R_{sa}) versus airflow velocity is shown in Figure 14.

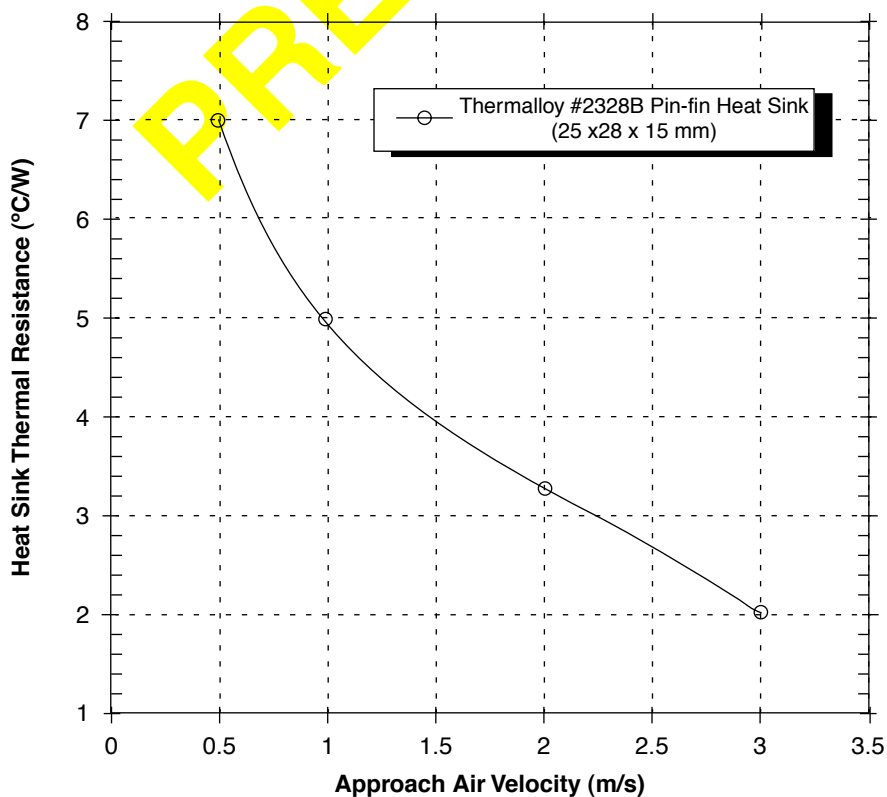

Figure 14. Thermalloy #2328B Heat Sink-to-Ambient Thermal Resistance Versus Airflow Velocity

Assuming an air velocity of 0.5 m/s, we have an effective R_{sa} of 5 °C/W, thus

$$T_j = 30\text{ °C} + 5\text{ °C} + (0.03\text{ °C/W} + 1.0\text{ °C/W} + 5\text{ °C/W}) * 7.5\text{ W},$$

resulting in a junction temperature of approximately 81 °C which is just below the maximum operating temperature of the part. To ensure maximum reliability, it is desirable to operate the 604e well within its operating temperature range. Thus, to keep a 7.5 W 604e within its proper operating range, an air velocity greater than 0.5 m/s should be used with the Thermalloy #2333B pin-fin heat sink.

Other heat sinks offered by Thermalloy, Aavid, Wakefield, and IERC offer different heat sink-to-ambient thermal resistances, and may or may not need air flow. It is necessary to perform an analysis as done above to select the desired heat sink.

Though the junction-to-ambient and the heat sink-to-ambient thermal resistances are commonly used to compare the thermal performance of various microelectronic packaging technologies, one should exercise caution when only using this metric in determining thermal management because no single parameter can adequately describe three-dimensional heat flow. The final chip-junction operating temperature is not only a function of the component-level thermal resistance, but the system-level design and its operating conditions. In addition to the component's power consumption, a number of factors affect the final operating die-junction temperature. These factors might include airflow, board population (local heat flux of adjacent components), heat sink efficiency, heat sink attach, next-level interconnect technology, system air temperature rise, etc. Due to the complexity and the many variations of system-level boundary conditions for today's microelectronic equipment, the combined effects of the heat transfer mechanisms (radiation, convection and conduction) may vary widely. For these reasons, we recommend using conjugate heat transfer models for the board as well as system-level designs. To expedite system-level thermal analysis, several “compact” thermal-package models are available within FLOTHERM®. These are available upon request.

1.9 Ordering Information

This section provides the part numbering nomenclature for the 604e. Note that the individual part numbers correspond to a specific combination of 604e internal/bus frequencies, which must be observed to ensure proper operation of the device. For available frequency combinations, contact your local Motorola or IBM sales office.

In addition to the processor frequency and bus ratio, the part numbering scheme also consists of a part modifier. The part modifier indicates the enhancement in the part from the original production design. Each part number also contains a revision code. This refers to the die mask revision number and is specified in the part numbering scheme for identification purposes only.

1.9.1 Motorola Part Number Key

Figure 15 provides the Motorola part numbering nomenclature for the 604e.

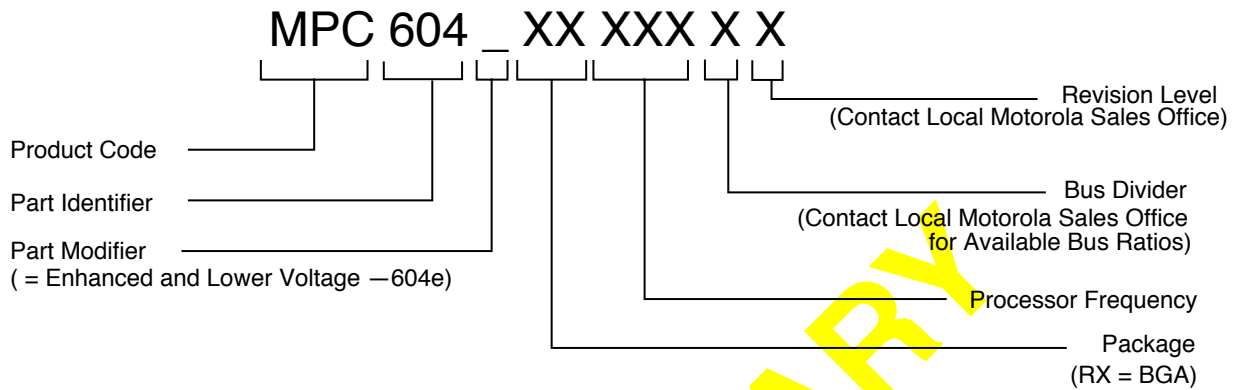

Figure 15. Motorola Part Number Key

1.9.2 IBM Part Number Information

Contact your local IBM sales office for 604e part number and availability information.

Information in this document is provided solely to enable system and software implementers to use PowerPC microprocessors. There are no express or implied copyright or patent licenses granted hereunder by Motorola or IBM to design, modify the design of, or fabricate circuits based on the information in this document.

The PowerPC 604e microprocessor embodies the intellectual property of Motorola and of IBM. However, neither Motorola nor IBM assumes any responsibility or liability as to any aspects of the performance, operation, or other attributes of the microprocessor as marketed by the other party or by any third party. Neither Motorola nor IBM is to be considered an agent or representative of the other party or any third party, and neither has assumed, created, or granted hereby any right or authority to the other, or to any third party, to assume or create any express or implied obligations on its behalf. Information such as errata sheets and data sheets, as well as sales terms and conditions such as prices, schedules, and support, for the product may vary as between parties selling the product. Accordingly, customers wishing to learn more information about the products as marketed by a given party should contact that party.

Both Motorola and IBM reserve the right to modify this document and/or any of the products as described herein without further notice. **NOTHING IN THIS DOCUMENT, NOR IN ANY OF THE ERRATA SHEETS, DATA SHEETS, AND OTHER SUPPORTING DOCUMENTATION, SHALL BE INTERPRETED AS THE CONVEYANCE BY MOTOROLA OR IBM OF AN EXPRESS WARRANTY OF ANY KIND OR IMPLIED WARRANTY, REPRESENTATION, OR GUARANTEE REGARDING THE MERCHANTABILITY OR FITNESS OF THE PRODUCTS FOR ANY PARTICULAR PURPOSE.** Neither Motorola nor IBM assumes any liability or obligation for damages of any kind arising out of the application or use of these materials. Any warranty or other obligations as to the products described herein shall be undertaken solely by the marketing party to the customer, under a separate sale agreement between the marketing party and the customer. In the absence of such an agreement, no liability is assumed by Motorola, IBM, or the marketing party for any damages, actual or otherwise.

"Typical" parameters can and do vary in different applications. All operating parameters, including "Typicals," must be validated for each customer application by customer's technical experts. Neither Motorola nor IBM convey any license under their respective intellectual property rights nor the rights of others. Neither Motorola nor IBM makes any claim, warranty, or representation, express or implied, that the products described in this document are designed, intended, or authorized for use as components in systems intended for surgical implant into the body, or other applications intended to support or sustain life, or for any other application in which the failure of the product could create a situation where personal injury or death may occur. Should customer purchase or use the products for any such unintended or unauthorized application, customer shall indemnify and hold Motorola and IBM and their respective officers, employees, subsidiaries, affiliates, and distributors harmless against all claims, costs, damages, and expenses, and reasonable attorney's fees arising out of, directly or indirectly, any claim of personal injury or death associated with such unintended or unauthorized use, even if such claim alleges that Motorola or IBM was negligent regarding the design or manufacture of the part.

Motorola and  are registered trademarks and Mfax is a trademark of Motorola, Inc. Motorola, Inc. is an Equal Opportunity/Affirmative Action Employer.

IBM, the IBM logo, and IBM Microelectronics are trademarks of International Business Machines Corporation.

The PowerPC name is a registered trademark and the PowerPC logotype, PowerPC 604 and PowerPC 604e are trademarks of International Business Machines Corporation, used by Motorola under license from International Business Machines Corporation. International Business Machines Corporation is an Equal Opportunity/Affirmative Action Employer.

International Business Machines Corporation:

IBM Microelectronics Division, 1580 Route 52, Bldg. 504, Hopewell Junction, NY 12533-6531; Tel. (800) PowerPC

World Wide Web Address: <http://www.chips.ibm.com/products/ppc>
<http://www.ibm.com>

Motorola Literature Distribution Centers:

USA/EUROPE: Motorola Literature Distribution; P.O. Box 5405; Denver, Colorado 80217; Tel.: 1-800-441-2447 or (303) 675-2140

JAPAN: Nippon Motorola Ltd.; Tatsumi-SPD-JLDC, 6F Seibu-Butsuryu-Center, 3-14-2 Tatsumi Koto-Ku, Tokyo 135, Japan; Tel.: 81-3-3521-8315

ASIA/PACIFIC: Motorola Semiconductors H.K. Ltd.; 8B Tai Ping Industrial Park, 51 Ting Kok Road, Tai Po, N.T., Hong Kong; Tel.: 852-26629298

Technical Information: Motorola Inc. SPS Customer Support Center; (800) 521-6274; electronic mail address: crc@wmkmail.sps.mot.com.

Document Comments: FAX (512) 891-2638, Attn: RISC Applications Engineering.

