

Low Voltage 1:9 Clock Distribution Chip

The MPC947 is a 1:9 low voltage clock distribution chip. The device features the capability to select between two LVTTTL compatible inputs and fans the signal out to 9 LVCMOS or LVTTTL compatible outputs. These 9 outputs were designed and optimized to drive 50Ω series terminated transmission lines. With output-to-output skews of 500ps, the MPC947 is ideal as a clock distribution chip for synchronous systems which need a tight level of skew at a relatively low cost. For a similar product targeted at a higher price/performance point, consult the MPC948 data sheet.

- Clock Distribution for PowerPC™ 620 L2 Cache
- 2 Selectable LVCMOS/LVTTTL Clock Inputs
- 500ps Maximum Output-to-Output Skew
- Drives Up to 18 Independent Clock Lines
- Maximum Output Frequency of 110MHz
- Synchronous Output Enable
- Tristatable Outputs
- 32-Lead TQFP Packaging
- 3.3V V_{CC} Supply Voltage

With an output impedance of approximately 7Ω, in both the HIGH and LOW logic states, the output buffers of the MPC947 are ideal for driving series terminated transmission lines. More specifically, each of the 9 MPC947 outputs can drive two series terminated 50Ω transmission lines. With this capability, the MPC947 has an effective fanout of 1:18 in applications using point-to-point distribution schemes. With this level of fanout, the MPC947 provides enough copies of low skew clocks for high performance synchronous systems, including use as a clock distribution chip for the L2 cache of a PowerPC 620 based system.

Two independent LVCMOS/LVTTTL compatible clock inputs are available. Designers can take advantage of this feature to provide redundant clock sources or the addition of a test clock into the system design. With the select input pulled HIGH, the TTL_CLK1 input will be selected.

All of the control inputs are LVCMOS/LVTTTL compatible. The MPC947 provides a synchronous output enable control to allow for starting and stopping of the output clocks. A logic high on the Sync_OE pin will enable all of the outputs. Because this control is synchronized to the input clock, potential output glitching or runt pulse generation is eliminated. In addition, for board level test, the outputs can be tristated via the tristate control pin. A logic LOW applied to the Tristate input will force all of the outputs into high impedance. Note that all of the MPC947 inputs have internal pullup resistors.

The MPC947 is fully 3.3V compatible. The 32-lead TQFP package was chosen to optimize performance, board space and cost of the device. The 32-lead TQFP has a 7x7mm body size with a conservative 0.8mm pin spacing.

MPC947

**LOW VOLTAGE
1:9 CLOCK
DISTRIBUTION CHIP**

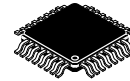

FA SUFFIX
32-LEAD TQFP PACKAGE
CASE 873A-02

PowerPC is a trademark of International Business Machines Corporation.



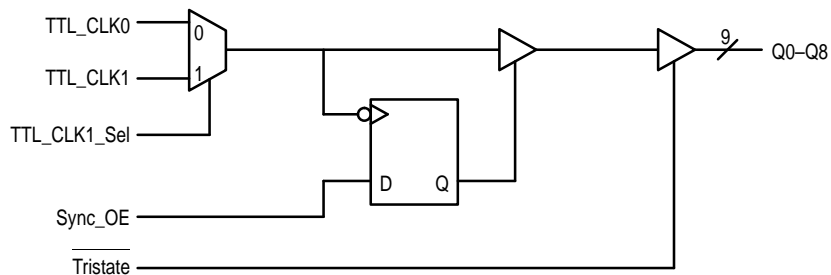

Figure 1. Logic Diagram

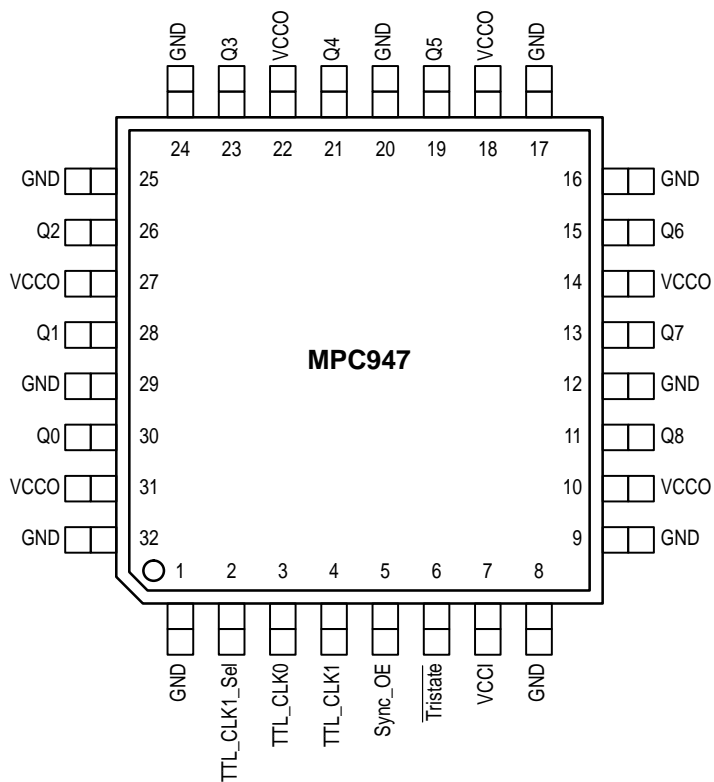

Figure 2. 32-Lead Pinout (Top View)

FUNCTION TABLES

TTL_CLK1_Sel	Input
0	TTL_CLK0
1	TTL_CLK1
Sync_OE	Outputs
0	Disabled
1	Enabled
Tristate	Outputs
0	Tristate
1	Enabled

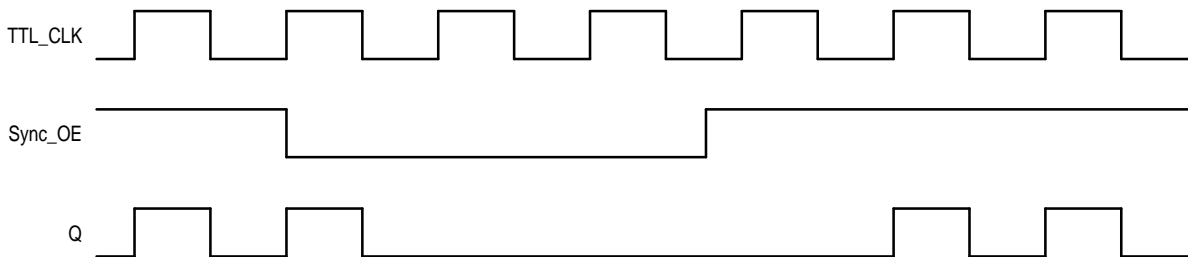

Figure 3. Sync_OE Timing Diagram

ABSOLUTE MAXIMUM RATINGS*

Symbol	Parameter	Min	Max	Unit
V _{CC}	Supply Voltage	-0.3	4.6	V
V _I	Input Voltage	-0.3	V _{DD} + 0.3	V
I _{IN}	Input Current (CMOS Inputs)		±20	mA
T _{Stor}	Storage Temperature Range	-40	125	°C

* Absolute maximum continuous ratings are those values beyond which damage to the device may occur. Exposure to these conditions or conditions beyond those indicated may adversely affect device reliability. Functional operation under absolute-maximum-rated conditions is not implied.

DC CHARACTERISTICS (T_A = 0° to 70°C, V_{CC} = 3.3V ±0.3V)

Symbol	Characteristic	Min	Typ	Max	Unit	Condition
V _{IH}	Input HIGH Voltage	2.0		3.6	V	
V _{IL}	Input LOW Voltage			0.8	V	
V _{OH}	Output HIGH Voltage	2.5			V	I _{OH} = -20mA (Note 1.)
V _{OL}	Output LOW Voltage			0.4	V	I _{OL} = 20mA (Note 1.)
I _{IN}	Input Current			-100	μA	Note 2.
I _{CC}	Maximum Quiescent Supply Current		21	28	mA	
C _{IN}	Input Capacitance			4	pF	
C _{pd}	Power Dissipation Capacitance		25		pF	Per Output

1. The MPC947 outputs can drive series or parallel terminated 50Ω (or 50Ω to V_{CC}/2) transmission lines on the incident edge (see Applications Info section).
2. I_{IN} current is a result of internal pull-up resistors.

AC CHARACTERISTICS (T_A = 0° to 70°C, V_{CC} = 3.3V ±0.3V)

Symbol	Characteristic	Min	Typ	Max	Unit	Condition
F _{max}	Maximum Input Frequency	110			MHz	Note 3.
t _{pd}	Propagation Delay TCLK to Q	4.75		9.25	ns	Note 3.
t _{sk(o)}	Output-to-Output Skew			500	ps	Note 3.
t _{sk(pr)}	Part-to-Part Skew			2.0	ns	Notes 3., 4.
t _{pwo}	Output Pulse Width	t _{CYCLE} /2 - 800		t _{CYCLE} /2 + 800	ps	Note 3., Measured at V _{CC} /2
t _s	Setup Time Sync_OE to Input Clk	0.0			ns	Notes 3., 5.
t _h	Hold Time Input Clk to Sync_OE	1.0			ns	Notes 3., 5.
t _{pZL} , t _{pZH}	Output Enable Time			11	ns	
t _{pLZ} , t _{pHZ}	Output Disable Time			11	ns	
t _r , t _f	Output Rise/Fall Time	0.2		1.0	ns	0.8V to 2.0V

3. Driving 50Ω terminated to V_{CC}/2.
4. Part-to-part skew at a given temperature and voltage.
5. Setup and Hold times are relative to the falling edge of the input clock.

APPLICATIONS INFORMATION

Driving Transmission Lines

The MPC947 clock driver was designed to drive high speed signals in a terminated transmission line environment. To provide the optimum flexibility to the user the output drivers were designed to exhibit the lowest impedance possible. With an output impedance of less than 10Ω the drivers can drive either parallel or series terminated transmission lines. For more information on transmission lines the reader is referred to application note AN1091 in the Timing Solutions brochure (BR1333/D).

In most high performance clock networks point-to-point distribution of signals is the method of choice. In a point-to-point scheme either series terminated or parallel terminated transmission lines can be used. The parallel technique terminates the signal at the end of the line with a 50Ω resistance to VCC/2. This technique draws a fairly high level of DC current and thus only a single terminated line can be driven by each output of the MPC947 clock driver. For the series terminated case however there is no DC current draw, thus the outputs can drive multiple series terminated lines. Figure 4 illustrates an output driving a single series terminated line vs two series terminated lines in parallel.

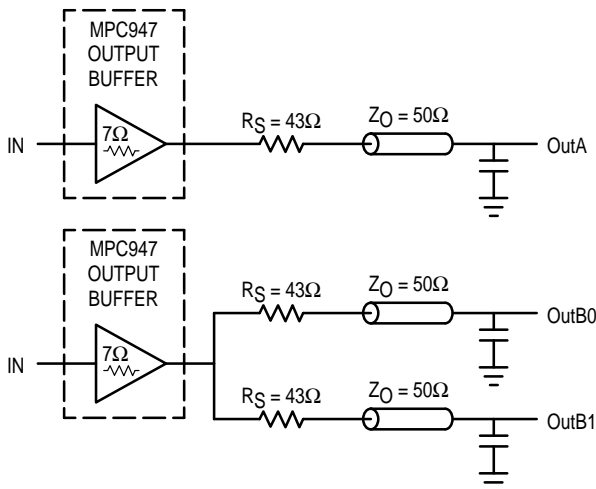

Figure 4. Single versus Dual Transmission Lines

The waveform plots of Figure 5 show the simulation results of an output driving a single line vs two lines. In both cases the drive capability of the MPC947 output buffers is more than sufficient to drive 50Ω transmission lines on the incident edge. Note from the delay measurements in the simulations a delta of only 43ps exists between the two differently loaded outputs. This suggests that the dual line driving need not be used exclusively to maintain the tight output-to-output skew of the MPC947. The output waveform in Figure 5 shows a step in the waveform, this step is caused by the impedance mismatch seen looking into the driver. The parallel combination of the 43Ω series resistor plus the output impedance does not match the parallel combination of the

line impedances. The voltage wave launched down the two lines will equal:

$$V_L = V_S (Z_o / R_s + R_o + Z_o) = 3.0 (25 / 53.5) = 1.40V$$

At the load end the voltage will double, due to the near unity reflection coefficient, to 2.8V. It will then increment towards the quiescent 3.0V in steps separated by one round trip delay (in this case 4.0ns).

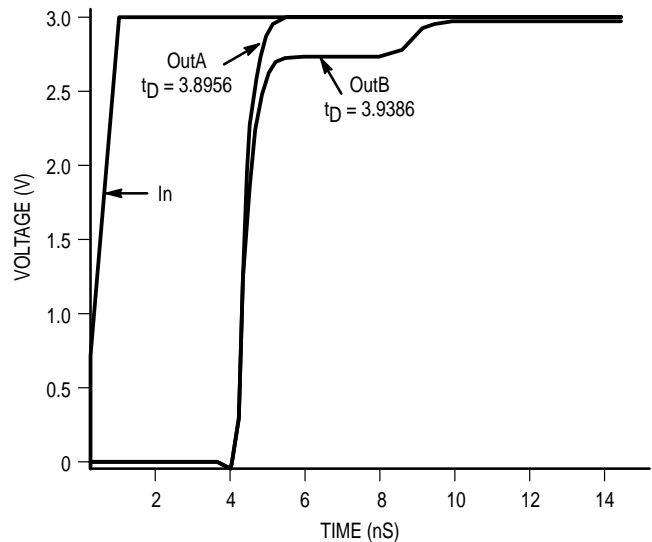

Figure 5. Single versus Dual Waveforms

Since this step is well above the threshold region it will not cause any false clock triggering, however designers may be uncomfortable with unwanted reflections on the line. To better match the impedances when driving multiple lines the situation in Figure 6 should be used. In this case the series terminating resistors are reduced such that when the parallel combination is added to the output buffer impedance the line impedance is perfectly matched.

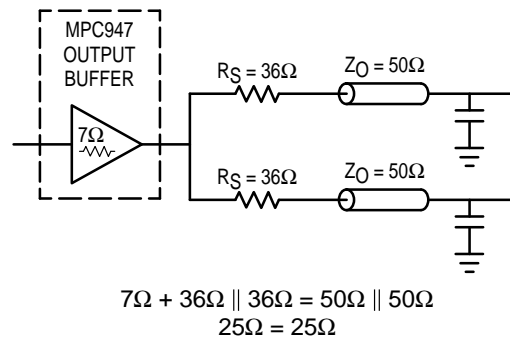
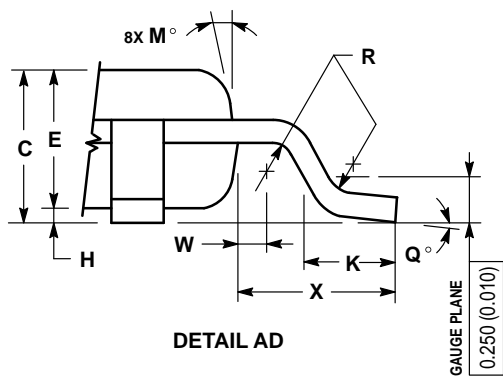
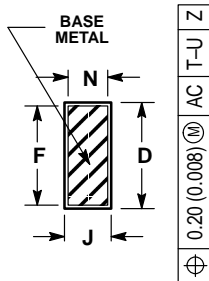
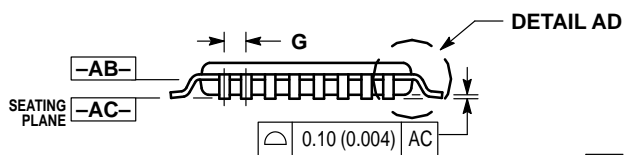
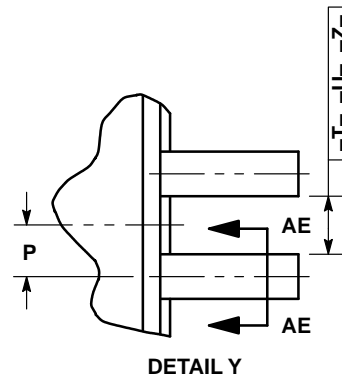
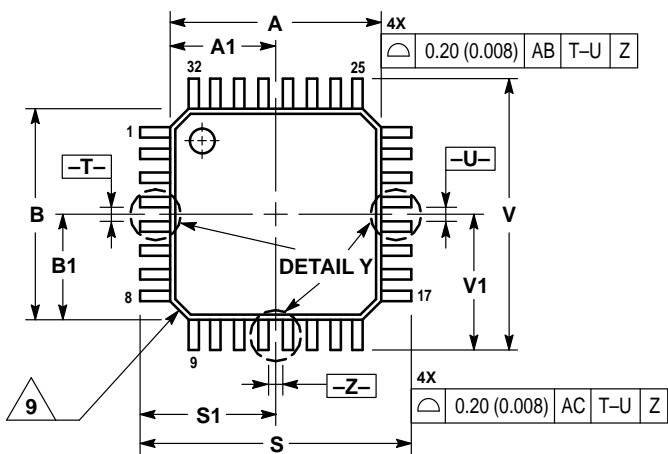

Figure 6. Optimized Dual Line Termination

SPICE level output buffer models are available for engineers who want to simulate their specific interconnect schemes. In addition IV characteristics are in the process of being generated to support the other board level simulators in general use.

OUTLINE DIMENSIONS

FA SUFFIX
TQFP PACKAGE
CASE 873A-02
ISSUE A



- NOTES:
1. DIMENSIONING AND TOLERANCING PER ANSI Y14.5M, 1982.
 2. CONTROLLING DIMENSION: MILLIMETER.
 3. DATUM PLANE -AB- IS LOCATED AT BOTTOM OF LEAD AND IS COINCIDENT WITH THE LEAD WHERE THE LEAD EXITS THE PLASTIC BODY AT THE BOTTOM OF THE PARTING LINE.
 4. DATUMS -T-, -U-, AND -Z- TO BE DETERMINED AT DATUM PLANE -AB-.
 5. DIMENSIONS S AND V TO BE DETERMINED AT SEATING PLANE -AC-.
 6. DIMENSIONS A AND B DO NOT INCLUDE MOLD PROTRUSION. ALLOWABLE PROTRUSION IS 0.250 (0.010) PER SIDE. DIMENSIONS A AND B DO INCLUDE MOLD MISMATCH AND ARE DETERMINED AT DATUM PLANE -AB-.
 7. DIMENSION D DOES NOT INCLUDE DAMBAR PROTRUSION. DAMBAR PROTRUSION SHALL NOT CAUSE THE D DIMENSION TO EXCEED 0.520 (0.020).
 8. MINIMUM SOLDER PLATE THICKNESS SHALL BE 0.0076 (0.0003).
 9. EXACT SHAPE OF EACH CORNER MAY VARY FROM DEPICTION.

DIM	MILLIMETERS		INCHES	
	MIN	MAX	MIN	MAX
A	7.000	BSC	0.276	BSC
A1	3.500	BSC	0.138	BSC
B	7.000	BSC	0.276	BSC
B1	3.500	BSC	0.138	BSC
C	1.400	1.600	0.055	0.063
D	0.300	0.450	0.012	0.018
E	1.350	1.450	0.053	0.057
F	0.300	0.400	0.012	0.016
G	0.800	BSC	0.031	BSC
H	0.050	0.150	0.002	0.006
J	0.090	0.200	0.004	0.008
K	0.500	0.700	0.020	0.028
M	12°	REF	12°	REF
N	0.090	0.160	0.004	0.006
P	0.400	BSC	0.016	BSC
Q	1°	5°	1°	5°
R	0.150	0.250	0.006	0.010
S	9.000	BSC	0.354	BSC
S1	4.500	BSC	0.177	BSC
V	9.000	BSC	0.354	BSC
V1	4.500	BSC	0.177	BSC
W	0.200	REF	0.008	REF
X	1.000	REF	0.039	REF

Motorola reserves the right to make changes without further notice to any products herein. Motorola makes no warranty, representation or guarantee regarding the suitability of its products for any particular purpose, nor does Motorola assume any liability arising out of the application or use of any product or circuit, and specifically disclaims any and all liability, including without limitation consequential or incidental damages. "Typical" parameters which may be provided in Motorola data sheets and/or specifications can and do vary in different applications and actual performance may vary over time. All operating parameters, including "Typicals" must be validated for each customer application by customer's technical experts. Motorola does not convey any license under its patent rights nor the rights of others. Motorola products are not designed, intended, or authorized for use as components in systems intended for surgical implant into the body, or other applications intended to support or sustain life, or for any other application in which the failure of the Motorola product could create a situation where personal injury or death may occur. Should Buyer purchase or use Motorola products for any such unintended or unauthorized application, Buyer shall indemnify and hold Motorola and its officers, employees, subsidiaries, affiliates, and distributors harmless against all claims, costs, damages, and expenses, and reasonable attorney fees arising out of, directly or indirectly, any claim of personal injury or death associated with such unintended or unauthorized use, even if such claim alleges that Motorola was negligent regarding the design or manufacture of the part. Motorola and  are registered trademarks of Motorola, Inc. Motorola, Inc. is an Equal Opportunity/Affirmative Action Employer.

How to reach us:

USA/EUROPE/Locations Not Listed: Motorola Literature Distribution;
P.O. Box 5405; Denver, Colorado 80217. 303-675-2140 or 1-800-441-2447

Mfax™: RMFAX0@email.sps.mot.com – TOUCHTONE 602-244-6609
INTERNET: <http://www.mot.com/sps/>

JAPAN: Nippon Motorola Ltd.; Tatsumi-SPD-JLDC, 6F Seibu-Butsuryu-Center,
3-14-2 Tatsumi Koto-Ku, Tokyo 135, Japan. 81-3-3521-8315

ASIA/PACIFIC: Motorola Semiconductors H.K. Ltd.; 8B Tai Ping Industrial Park,
51 Ting Kok Road, Tai Po, N.T., Hong Kong. 852-26629298

