

The RF Line
NPN Silicon
RF Power Transistor

MRF6414

50 W, 960 MHz
RF POWER TRANSISTOR
NPN SILICON

The MRF6414 is designed for 26 volt UHF large signal, common emitter, class AB linear amplifier applications.

- Specified 26 Volt, 960 MHz Characteristics
Output Power = 50 Watts
Minimum Gain = 8.5 dB @ 960 MHz, Class AB
Minimum Efficiency = 50% @ 960 MHz, 50 Watts
- Silicon Nitride Passivated
- Gold Metallized, Emitter Ballasted for Long Life and Resistance to Metal Migration

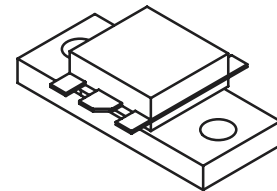

CASE 333A-02, STYLE 2

ARCHIVE INFORMATION

ARCHIVE INFORMATION

MAXIMUM RATINGS

Rating	Symbol	Value	Unit
Collector-Emitter Voltage	V_{CEO}	28	Vdc
Collector-Base Voltage	V_{CBO}	65	Vdc
Emitter-Base Voltage	V_{EBO}	4	Vdc
Collector-Current — Continuous	I_C	6	Adc
Total Device Dissipation @ $T_C = 25^\circ\text{C}$ Derate above 25°C	P_D	134 0.77	Watts W/ $^\circ\text{C}$
Storage Temperature Range	T_{stg}	-65 to +150	$^\circ\text{C}$

THERMAL CHARACTERISTICS

Characteristic	Symbol	Max	Unit
Thermal Resistance, Junction to Case	$R_{\theta JC}$	1.3	$^\circ\text{C}/\text{W}$

ELECTRICAL CHARACTERISTICS ($T_C = 25^\circ\text{C}$ unless otherwise noted)

Characteristic	Symbol	Min	Typ	Max	Unit
----------------	--------	-----	-----	-----	------

OFF CHARACTERISTICS

Collector-Emitter Breakdown Voltage ($I_C = 20 \text{ mAdc}$, $I_B = 0$)	$V_{(BR)CEO}$	28	—	—	Vdc
Collector-Base Breakdown Voltage ($I_C = 20 \text{ mAdc}$, $I_E = 0$)	$V_{(BR)CBO}$	65	—	—	Vdc
Emitter-Base Breakdown Voltage ($I_E = 10 \text{ mAdc}$, $I_C = 0$)	$V_{(BR)EBO}$	4	—	—	Vdc
Collector-Emitter Leakage Current ($V_{CE} = 30 \text{ Vdc}$, $R_{BE} = 75 \Omega$)	I_{CER}	—	—	10	mAdc

ON CHARACTERISTICS

DC Current Gain ($I_{CE} = 1 \text{ Adc}$, $V_{CE} = 5 \text{ Vdc}$)	h_{FE}	30	—	120	—
---	----------	----	---	-----	---



ELECTRICAL CHARACTERISTICS — continued ($T_C = 25^\circ\text{C}$ unless otherwise noted)

Characteristic	Symbol	Min	Typ	Max	Unit
DYNAMIC CHARACTERISTICS					
Output Capacitance ($V_{CB} = 26\text{ Vdc}$, $I_E = 0$, $f = 1\text{ MHz}$) (1)	C_{ob}	—	45	—	pF
FUNCTIONAL TESTS					
Common-Emitter Amplifier Power Gain ($V_{CC} = 26\text{ Vdc}$, $P_{out} = 50\text{ W}$, $I_{CQ} = 200\text{ mA}$, $f = 960\text{ MHz}$)	G_{pe}	8.5	—	—	dB
Collector Efficiency ($V_{CC} = 26\text{ Vdc}$, $P_{out} = 50\text{ W}$, $I_{CQ} = 200\text{ mA}$, $f = 960\text{ MHz}$)	η	50	55	—	%
Output Mismatch Stress ($V_{CC} = 26\text{ Vdc}$, $P_{out} = 50\text{ W}$, $I_{CQ} = 200\text{ mA}$, $f = 960\text{ MHz}$) VSWR = 3:1; all phase angles at frequency of test	Ψ	No Degradation in Output Power			

(1) For information only. It is not measurable in MRF6414 because of internal matching network.

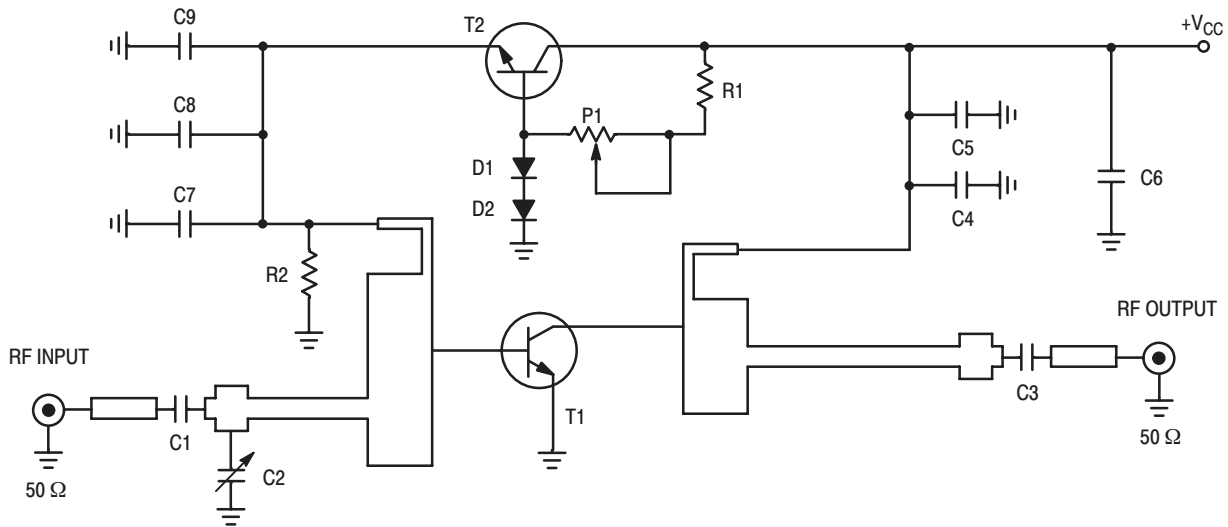

C1, C3	100 pF, Chip Capacitor, High Q	P1	1 k Ω , Trimmer
C2, C7	330 pF, Chip Capacitor, 0805	R1	1 k Ω , Resistor
C5, C8	10 nF, Chip Capacitor, 0805	R2	58 Ω , Resistor, 0805
C6	15 μF , Capacitor, 63 V	T1	MRF6414
C9	100 μF , Capacitor, 16 V	T2	Transistor NPN Type BD135
D1, D2	Diode 1N4007		

Figure 1. 960 MHz Test Circuit Schematic

TYPICAL CHARACTERISTICS

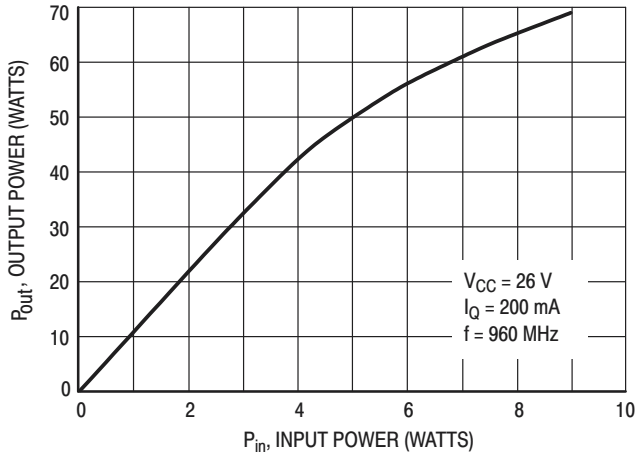

Figure 2. Output Power versus Input Power (Typical)

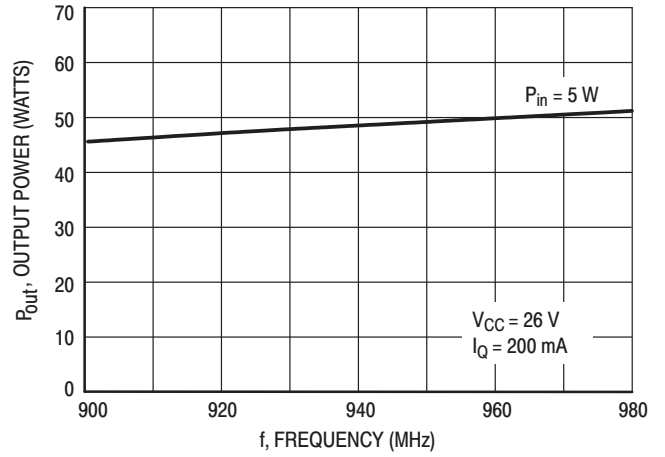

Figure 3. Output Power versus Frequency

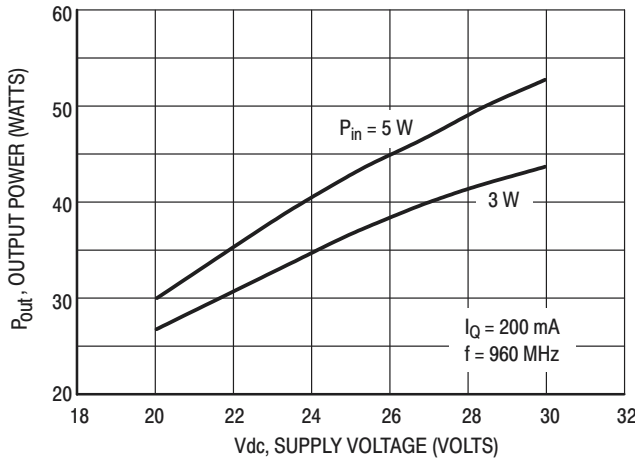

Figure 4. Output Power versus Supply Voltage

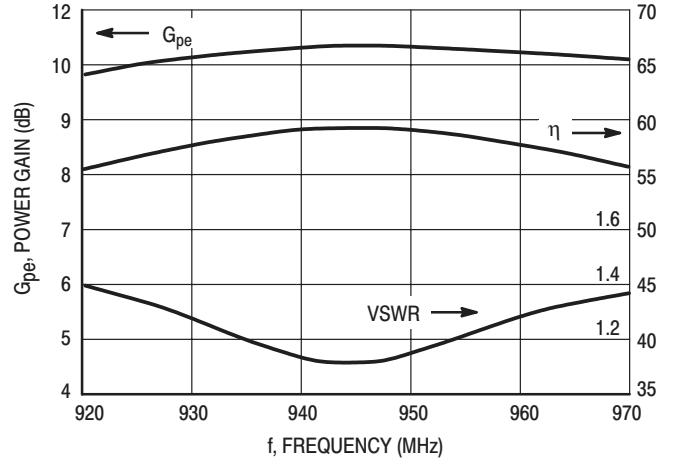
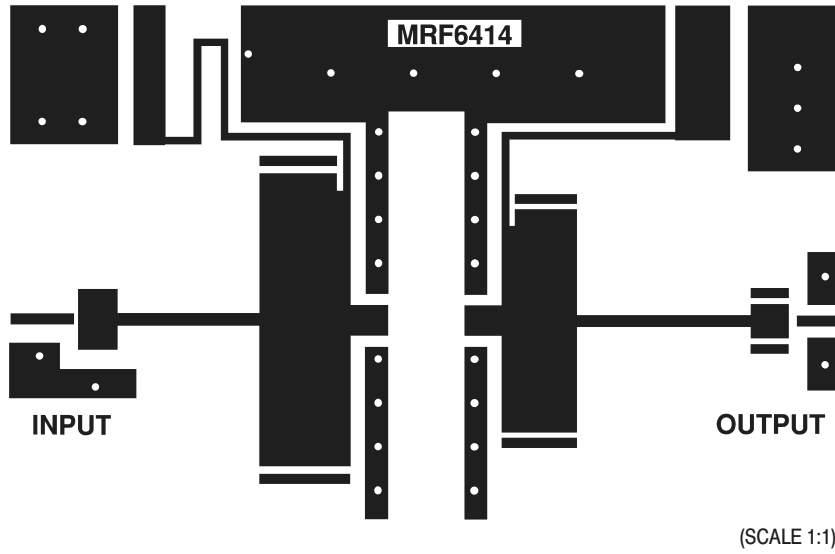

Figure 5. Typical Broadband Amplifier



TEST CIRCUIT @ $f = 960$ MHz
 TEFLON[®] GLASS 1/50 INCH $\epsilon_r = 2.55$

Figure 6. MRF6414 Photomaster
 (Reduced 18% in printed data book, DL110/D)

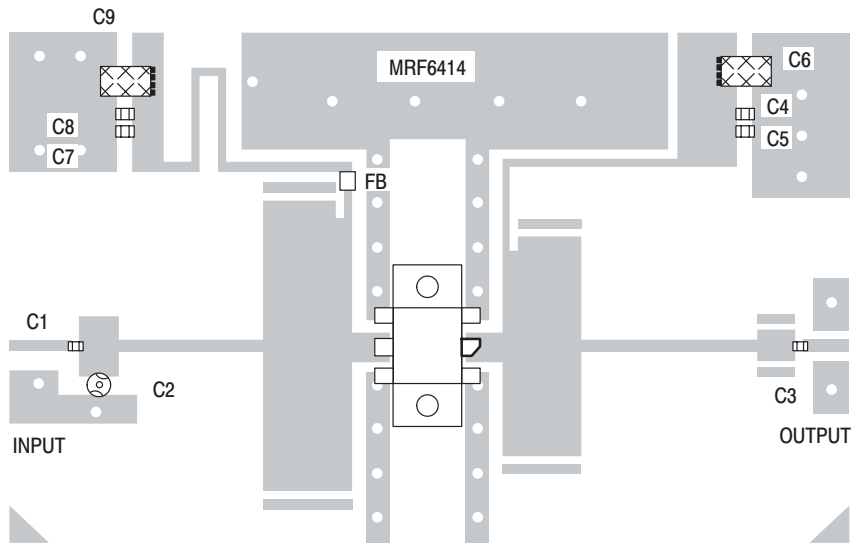
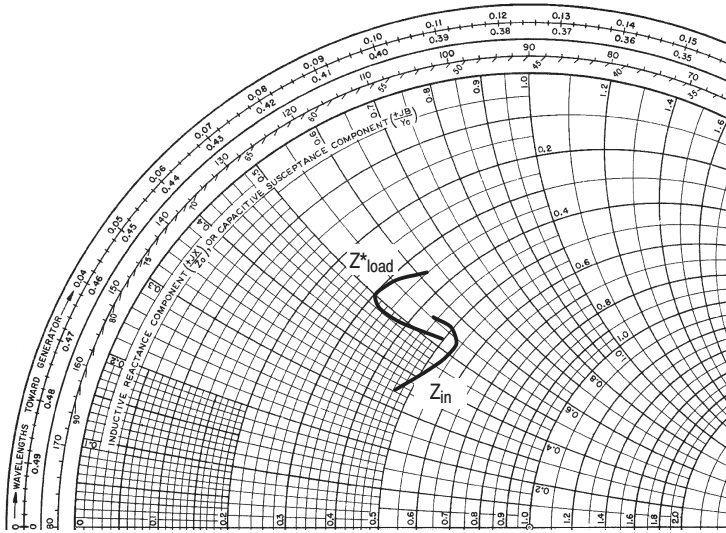

Figure 7. 960 MHz Test Circuit Components Layout



Normalized to 10 Ω

f MHz	Z _{in} Ohms	Z _{OL} * Ohms
900	4.4 + j4.6	4.7 + j4.7
935	5.1 + j4.8	4.0 + j3.9
960	5.4 + j3.6	3.7 + j4.5
980	4.7 + j2.5	3.4 + j4.7

Z_{OL}*: Conjugate of optimum load impedance into which the device operates at a given output power, voltage, current and frequency.

Figure 8. Input and Output Impedances with Circuit Tuned for Maximum Gain
 @ V_{CC} = 26 V, I_Q = 200 mA, P_{out} = 50 W

NOTES

NOTES

PACKAGE DIMENSIONS

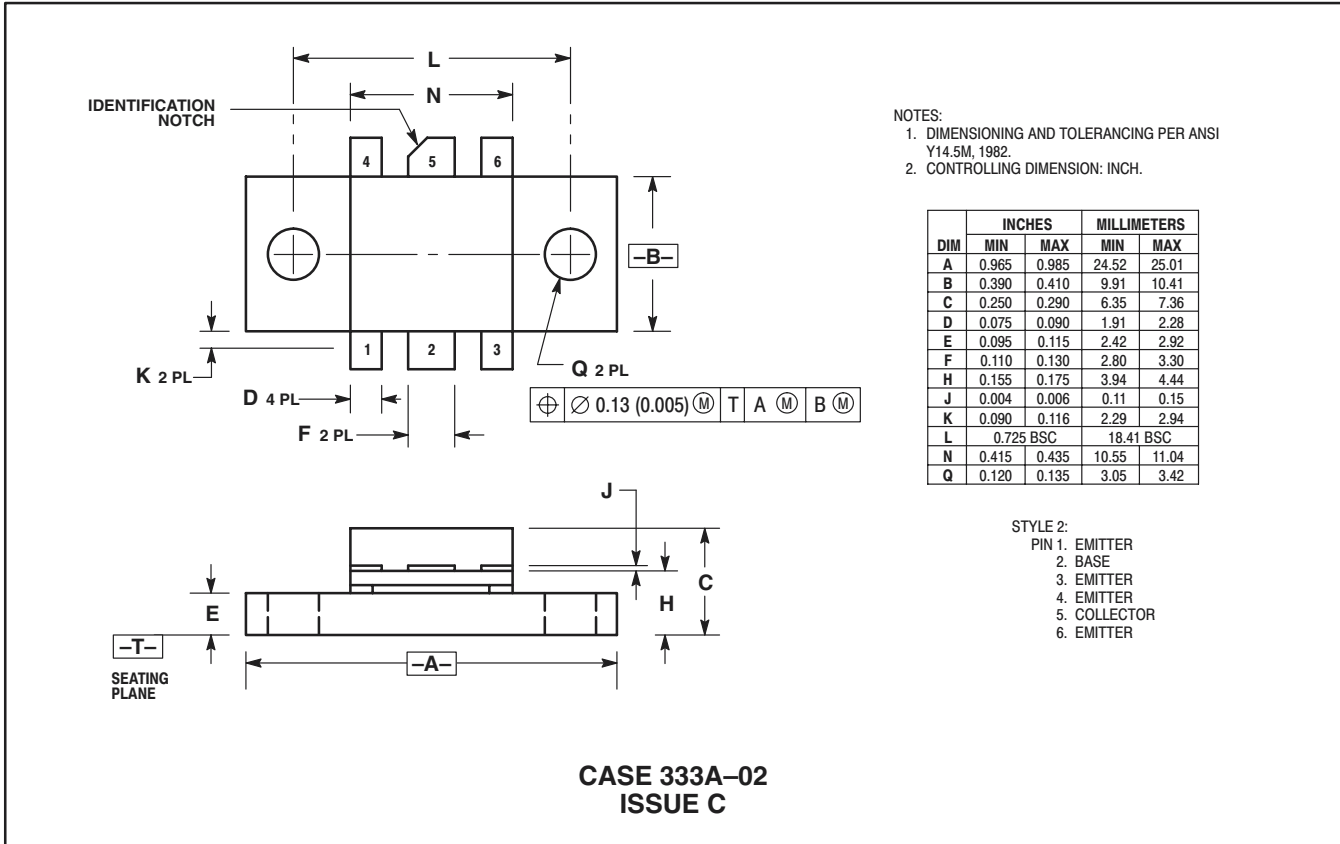

NOTES:
 1. DIMENSIONING AND TOLERANCING PER ANSI Y14.5M, 1982.
 2. CONTROLLING DIMENSION: INCH.

DIM	INCHES		MILLIMETERS	
	MIN	MAX	MIN	MAX
A	0.965	0.985	24.52	25.01
B	0.390	0.410	9.91	10.41
C	0.250	0.290	6.35	7.36
D	0.075	0.090	1.91	2.28
E	0.095	0.115	2.42	2.92
F	0.110	0.130	2.80	3.30
H	0.155	0.175	3.94	4.44
J	0.004	0.006	0.11	0.15
K	0.090	0.116	2.29	2.94
L	0.725 BSC		18.41 BSC	
N	0.415	0.435	10.55	11.04
Q	0.120	0.135	3.05	3.42

STYLE 2:
 PIN 1. EMITTER
 2. BASE
 3. EMITTER
 4. EMITTER
 5. COLLECTOR
 6. EMITTER

Motorola reserves the right to make changes without further notice to any products herein. Motorola makes no warranty, representation or guarantee regarding the suitability of its products for any particular purpose, nor does Motorola assume any liability arising out of the application or use of any product or circuit, and specifically disclaims any and all liability, including without limitation consequential or incidental damages. "Typical" parameters which may be provided in Motorola data sheets and/or specifications can and do vary in different applications and actual performance may vary over time. All operating parameters, including "Typicals" must be validated for each customer application by customer's technical experts. Motorola does not convey any license under its patent rights nor the rights of others. Motorola products are not designed, intended, or authorized for use as components in systems intended for surgical implant into the body, or other applications intended to support or sustain life, or for any other application in which the failure of the Motorola product could create a situation where personal injury or death may occur. Should Buyer purchase or use Motorola products for any such unintended or unauthorized application, Buyer shall indemnify and hold Motorola and its officers, employees, subsidiaries, affiliates, and distributors harmless against all claims, costs, damages, and expenses, and reasonable attorney fees arising out of, directly or indirectly, any claim of personal injury or death associated with such unintended or unauthorized use, even if such claim alleges that Motorola was negligent regarding the design or manufacture of the part. Motorola and are registered trademarks of Motorola, Inc. Motorola, Inc. is an Equal Opportunity/Affirmative Action Employer.

Mfax is a trademark of Motorola, Inc.

How to reach us:

USA/EUROPE/Locations Not Listed: Motorola Literature Distribution;
 P.O. Box 5405, Denver, Colorado 80217. 1-303-675-2140 or 1-800-441-2447

JAPAN: Nippon Motorola Ltd.: SPD, Strategic Planning Office, 141,
 4-32-1 Nishi-Gotanda, Shagawa-ku, Tokyo, Japan. 03-5487-8488

Customer Focus Center: 1-800-521-6274

Mfax™: RMFAX0@email.sps.mot.com – TOUCHTONE 1-602-244-6609
 Motorola Fax Back System – US & Canada ONLY 1-800-774-1848
 – http://sps.motorola.com/mfax/

ASIA/PACIFIC: Motorola Semiconductors H.K. Ltd.; 8B Tai Ping Industrial Park,
 51 Ting Kok Road, Tai Po, N.T., Hong Kong. 852-26629298

HOME PAGE: http://motorola.com/sps/

