

The RF Sub-Micron MOSFET Line
RF Power Field Effect Transistors
N-Channel Enhancement-Mode Lateral MOSFETs

MRF9045R1
MRF9045SR1

Designed for broadband commercial and industrial applications with frequencies up to 1.0 GHz. The high gain and broadband performance of these devices make them ideal for large-signal, common-source amplifier applications in 28 volt base station equipment.

- Typical Two-Tone Performance at 945 MHz, 28 Volts
Output Power — 45 Watts PEP
Power Gain — 18.8 dB
Efficiency — 42%
IMD — -32 dBc
- Integrated ESD Protection
- Designed for Maximum Gain and Insertion Phase Flatness
- Capable of Handling 10:1 VSWR, @ 28 Vdc, 945 MHz, 45 Watts CW Output Power
- Excellent Thermal Stability
- Characterized with Series Equivalent Large-Signal Impedance Parameters
- In Tape and Reel. R1 Suffix = 500 Units per 32 mm, 13 inch Reel.

945 MHz, 45 W, 28 V
LATERAL N-CHANNEL
BROADBAND
RF POWER MOSFETs

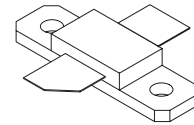

CASE 360B-05, STYLE 1
NI-360
MRF9045R1

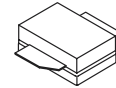

CASE 360C-05, STYLE 1
NI-360S
MRF9045SR1

MAXIMUM RATINGS

Rating		Symbol	Value	Unit
Drain-Source Voltage		V_{DSS}	65	Vdc
Gate-Source Voltage		V_{GS}	-0.5, +15	Vdc
Total Device Dissipation @ $T_C = 25^\circ\text{C}$ Derate above 25°C	MRF9045R1	P_D	125 0.71	Watts $\text{W}/^\circ\text{C}$
Total Device Dissipation @ $T_C = 25^\circ\text{C}$ Derate above 25°C	MRF9045SR1	P_D	175 1	Watts $\text{W}/^\circ\text{C}$
Storage Temperature Range		T_{stg}	-65 to +200	$^\circ\text{C}$
Operating Junction Temperature		T_J	200	$^\circ\text{C}$

ESD PROTECTION CHARACTERISTICS

Test Conditions	Class
Human Body Model	1 (Minimum)
Machine Model	M1 (Minimum)

THERMAL CHARACTERISTICS

Characteristic		Symbol	Max	Unit
Thermal Resistance, Junction to Case	MRF9045R1 MRF9045SR1	$R_{\theta JC}$	1.4 1.0	$^\circ\text{C}/\text{W}$

NOTE – **CAUTION** – MOS devices are susceptible to damage from electrostatic charge. Reasonable precautions in handling and packaging MOS devices should be observed.

ELECTRICAL CHARACTERISTICS ($T_C = 25^\circ\text{C}$ unless otherwise noted)

Characteristic	Symbol	Min	Typ	Max	Unit
OFF CHARACTERISTICS					
Zero Gate Voltage Drain Leakage Current ($V_{DS} = 65\text{ Vdc}$, $V_{GS} = 0\text{ Vdc}$)	I_{DSS}	—	—	10	μAdc
Zero Gate Voltage Drain Leakage Current ($V_{DS} = 28\text{ Vdc}$, $V_{GS} = 0\text{ Vdc}$)	I_{DSS}	—	—	1	μAdc
Gate–Source Leakage Current ($V_{GS} = 5\text{ Vdc}$, $V_{DS} = 0\text{ Vdc}$)	I_{GSS}	—	—	1	μAdc
ON CHARACTERISTICS					
Gate Threshold Voltage ($V_{DS} = 10\text{ Vdc}$, $I_D = 150\ \mu\text{Adc}$)	$V_{GS(th)}$	2	3	4	Vdc
Gate Quiescent Voltage ($V_{DS} = 28\text{ Vdc}$, $I_D = 350\text{ mAdc}$)	$V_{GS(Q)}$	—	3.7	—	Vdc
Drain–Source On–Voltage ($V_{GS} = 10\text{ Vdc}$, $I_D = 1\text{ Adc}$)	$V_{DS(on)}$	—	0.19	0.4	Vdc
Forward Transconductance ($V_{DS} = 10\text{ Vdc}$, $I_D = 3\text{ Adc}$)	g_{fs}	—	4	—	S
DYNAMIC CHARACTERISTICS					
Input Capacitance ($V_{DS} = 28\text{ Vdc} \pm 30\text{ mV(rms)ac}$ @ 1 MHz, $V_{GS} = 0\text{ Vdc}$)	C_{iss}	—	69	—	pF
Output Capacitance ($V_{DS} = 28\text{ Vdc} \pm 30\text{ mV(rms)ac}$ @ 1 MHz, $V_{GS} = 0\text{ Vdc}$)	C_{oss}	—	37	—	pF
Reverse Transfer Capacitance ($V_{DS} = 28\text{ Vdc} \pm 30\text{ mV(rms)ac}$ @ 1 MHz, $V_{GS} = 0\text{ Vdc}$)	C_{rss}	—	1.5	—	pF

(continued)

ELECTRICAL CHARACTERISTICS — continued ($T_C = 25^\circ\text{C}$ unless otherwise noted)

Characteristic	Symbol	Min	Typ	Max	Unit
FUNCTIONAL TESTS (In Motorola Test Fixture, 50 ohm system)					
Two-Tone Common-Source Amplifier Power Gain ($V_{DD} = 28\text{ Vdc}$, $P_{out} = 45\text{ W PEP}$, $I_{DQ} = 350\text{ mA}$, $f_1 = 945.0\text{ MHz}$, $f_2 = 945.1\text{ MHz}$)	G_{ps}	17	18.8	—	dB
Two-Tone Drain Efficiency ($V_{DD} = 28\text{ Vdc}$, $P_{out} = 45\text{ W PEP}$, $I_{DQ} = 350\text{ mA}$, $f_1 = 945.0\text{ MHz}$, $f_2 = 945.1\text{ MHz}$)	η	38	42	—	%
3rd Order Intermodulation Distortion ($V_{DD} = 28\text{ Vdc}$, $P_{out} = 45\text{ W PEP}$, $I_{DQ} = 350\text{ mA}$, $f_1 = 945.0\text{ MHz}$, $f_2 = 945.1\text{ MHz}$)	IMD	—	-32	-28	dBc
Input Return Loss ($V_{DD} = 28\text{ Vdc}$, $P_{out} = 45\text{ W PEP}$, $I_{DQ} = 350\text{ mA}$, $f_1 = 945.0\text{ MHz}$, $f_2 = 945.1\text{ MHz}$)	IRL	—	-14	-9	dB
Two-Tone Common-Source Amplifier Power Gain ($V_{DD} = 28\text{ Vdc}$, $P_{out} = 45\text{ W PEP}$, $I_{DQ} = 350\text{ mA}$, $f_1 = 930.0\text{ MHz}$, $f_2 = 930.1\text{ MHz}$ and $f_1 = 960.0\text{ MHz}$, $f_2 = 960.1\text{ MHz}$)	G_{ps}	—	18.5	—	dB
Two-Tone Drain Efficiency ($V_{DD} = 28\text{ Vdc}$, $P_{out} = 45\text{ W PEP}$, $I_{DQ} = 350\text{ mA}$, $f_1 = 930.0\text{ MHz}$, $f_2 = 930.1\text{ MHz}$ and $f_1 = 960.0\text{ MHz}$, $f_2 = 960.1\text{ MHz}$)	η	—	41	—	%
3rd Order Intermodulation Distortion ($V_{DD} = 28\text{ Vdc}$, $P_{out} = 45\text{ W PEP}$, $I_{DQ} = 350\text{ mA}$, $f_1 = 930.0\text{ MHz}$, $f_2 = 930.1\text{ MHz}$ and $f_1 = 960.0\text{ MHz}$, $f_2 = 960.1\text{ MHz}$)	IMD	—	-33	—	dBc
Input Return Loss ($V_{DD} = 28\text{ Vdc}$, $P_{out} = 45\text{ W PEP}$, $I_{DQ} = 350\text{ mA}$, $f_1 = 930.0\text{ MHz}$, $f_2 = 930.1\text{ MHz}$ and $f_1 = 960.0\text{ MHz}$, $f_2 = 960.1\text{ MHz}$)	IRL	—	13	—	dB
Power Output, 1 dB Compression Point ($V_{DD} = 28\text{ Vdc}$, $P_{out} = 45\text{ W CW}$, $I_{DQ} = 350\text{ mA}$, $f_1 = 945.0\text{ MHz}$)	P_{1dB}	—	55	—	W
Common-Source Amplifier Power Gain ($V_{DD} = 28\text{ Vdc}$, $P_{out} = 45\text{ W CW}$, $I_{DQ} = 350\text{ mA}$, $f_1 = 945.0\text{ MHz}$)	G_{ps}	—	18	—	dB
Drain Efficiency ($V_{DD} = 28\text{ Vdc}$, $P_{out} = 45\text{ W CW}$, $I_{DQ} = 350\text{ mA}$, $f_1 = 945.0\text{ MHz}$)	η	—	60	—	%
Output Mismatch Stress ($V_{DD} = 28\text{ Vdc}$, $P_{out} = 45\text{ W CW}$, $I_{DQ} = 350\text{ mA}$, $f = 945.0\text{ MHz}$, $V_{SWR} = 10:1$, All Phase Angles at Frequency of Tests)	Ψ	No Degradation In Output Power			

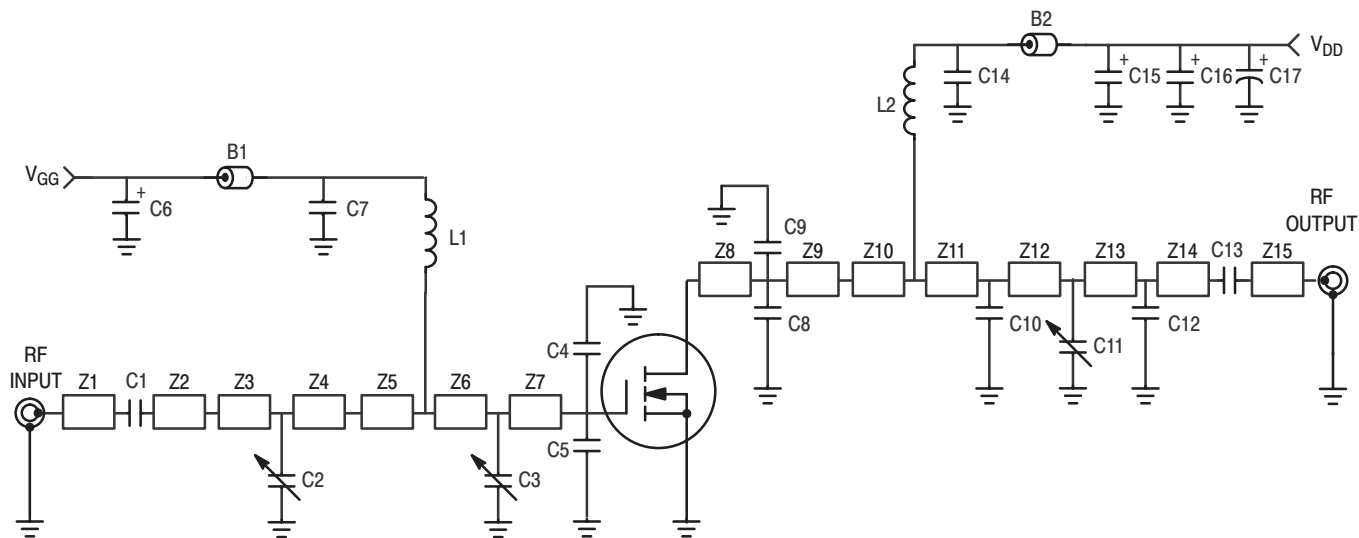

B1	Short Ferrite Bead Surface Mount	Z4	0.360" x 0.320" Microstrip
B2	Long Ferrite Bead Surface Mount	Z5	0.240" x 0.320" x 0.620", Taper
C1, C7, C13, C14	47 pF Chip Capacitors, B Case	Z6	0.140" x 0.620" Microstrip
C2, C3, C11	0.8–8.0 pF Gigatrim Variable Trim Capacitors	Z7	0.510" x 0.620" Microstrip
C4, C5, C8, C9	10 pF Chip Capacitors, B Case	Z8	0.330" x 0.320" Microstrip
C6, C15, C16	10 μ F, 35 V Tantalum Surface Mount Chip Capacitors	Z9	0.140" x 0.320" Microstrip
C10	2.2 pF Chip Capacitor, B Case	Z10	0.070" x 0.080" Microstrip
C12	0.7 pF Chip Capacitor, B Case – MRF9045S	Z11	0.240" x 0.080" Microstrip
	1.3 pF Chip Capacitor, B Case – MRF9045	Z12	0.140" x 0.080" Microstrip
C17	220 μ F, 50 V Electrolytic Capacitor	Z13	0.930" x 0.080" Microstrip
L1, L2	12.5 nH Surface Mount Inductors, Coilcraft	Z14	0.180" x 0.080" Microstrip
Z1	0.260" x 0.080" Microstrip	Z15	0.350" x 0.080" Microstrip
Z2	0.610" x 0.120" Microstrip	Printed Circuit Board	0.03" Glass Teflon®, $\epsilon_r = 2.55$
Z3	0.260" x 0.320" Microstrip	Board	ARLON GX-0300-55-22

Figure 1. 930 – 960 MHz Broadband Test Circuit Schematic

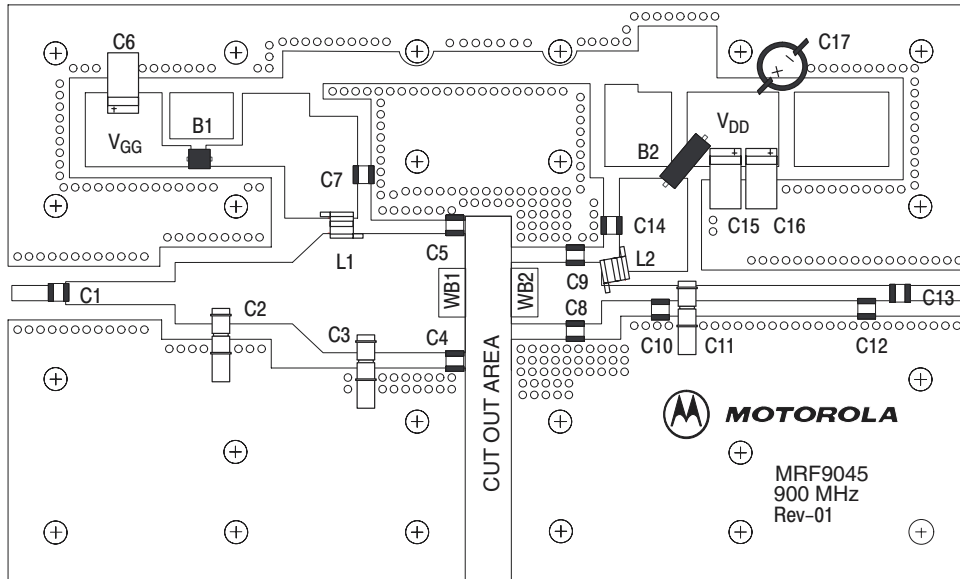

Figure 2. 930 – 960 MHz Broadband Test Circuit Component Layout

TYPICAL CHARACTERISTICS

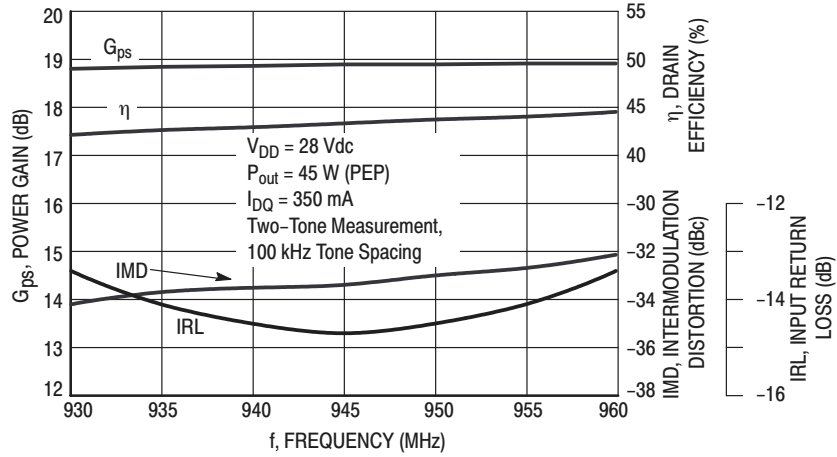

Figure 3. Class AB Broadband Circuit Performance

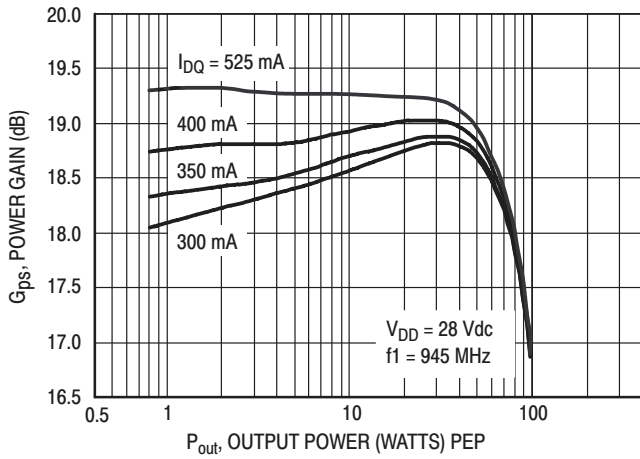

Figure 4. Power Gain versus Output Power

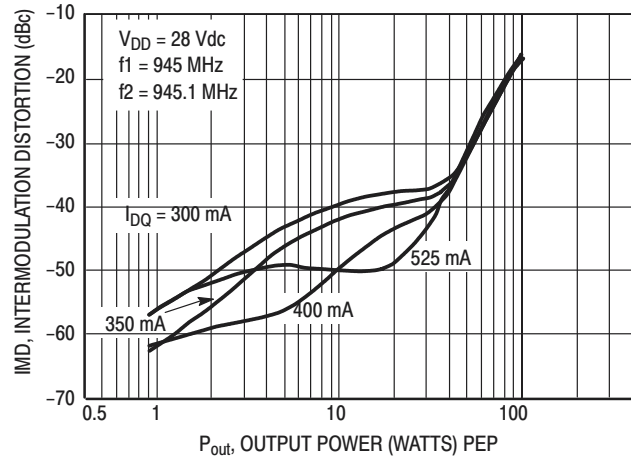

Figure 5. Intermodulation Distortion versus Output Power

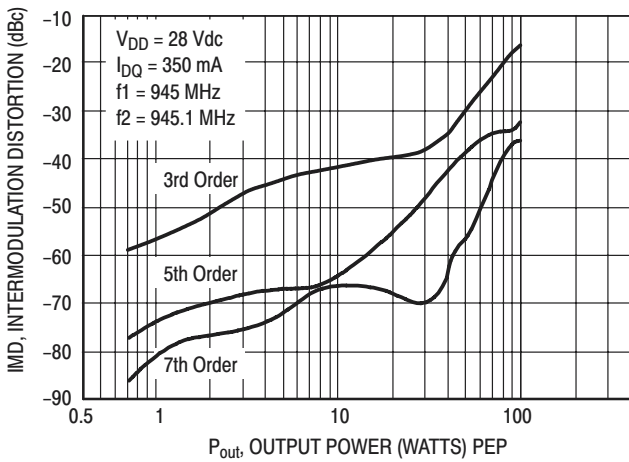

Figure 6. Intermodulation Distortion Products versus Output Power

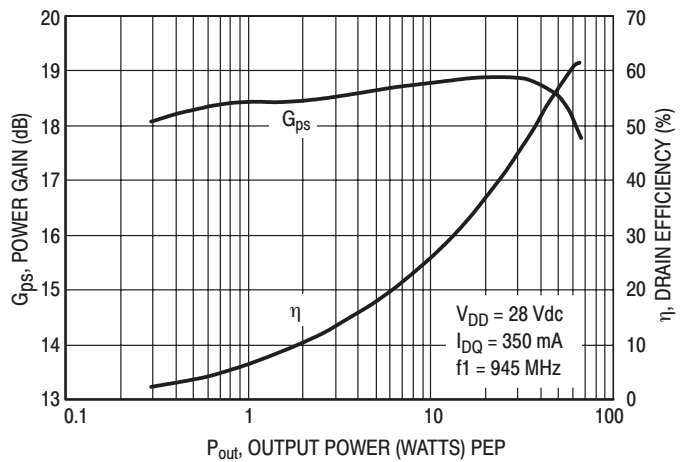
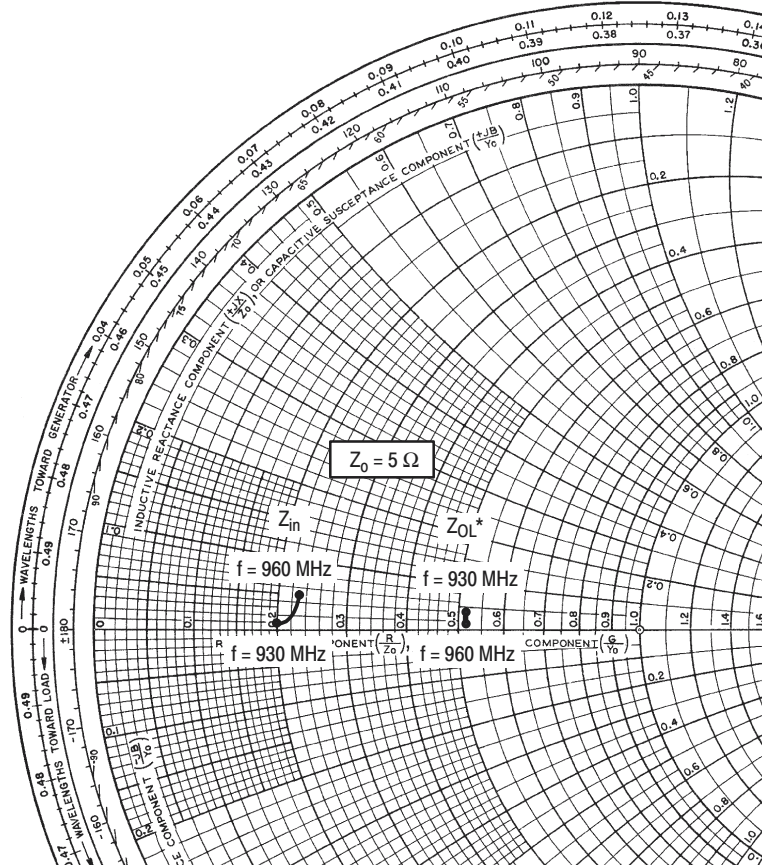

Figure 7. Power Gain, Efficiency versus Output Power



$V_{DD} = 28\text{ V}$, $I_{DQ} = 350\text{ mA}$, $P_{out} = 45\text{ W PEP}$

f MHz	Z_{in} Ω	Z_{OL}^* Ω
930	$1.02 + j0.06$	$2.6 + j0.20$
945	$1.10 + j0.11$	$2.6 + j0.16$
960	$1.15 + j0.25$	$2.6 + j0.10$

Z_{in} = Complex conjugate of source impedance.

Z_{OL}^* = Complex conjugate of the optimum load impedance at a given output power, voltage, IMD, bias current and frequency.

Note: Z_{OL}^* was chosen based on tradeoffs between gain, output power, drain efficiency and intermodulation distortion.

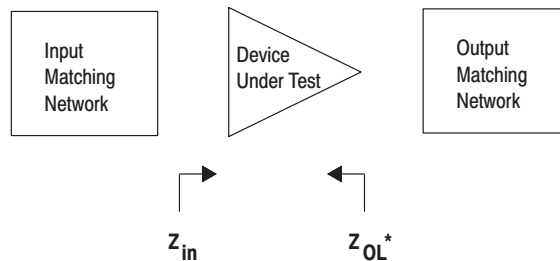

Figure 8. Series Equivalent Input and Output Impedance

NOTES

NOTES

NOTES

PACKAGE DIMENSIONS

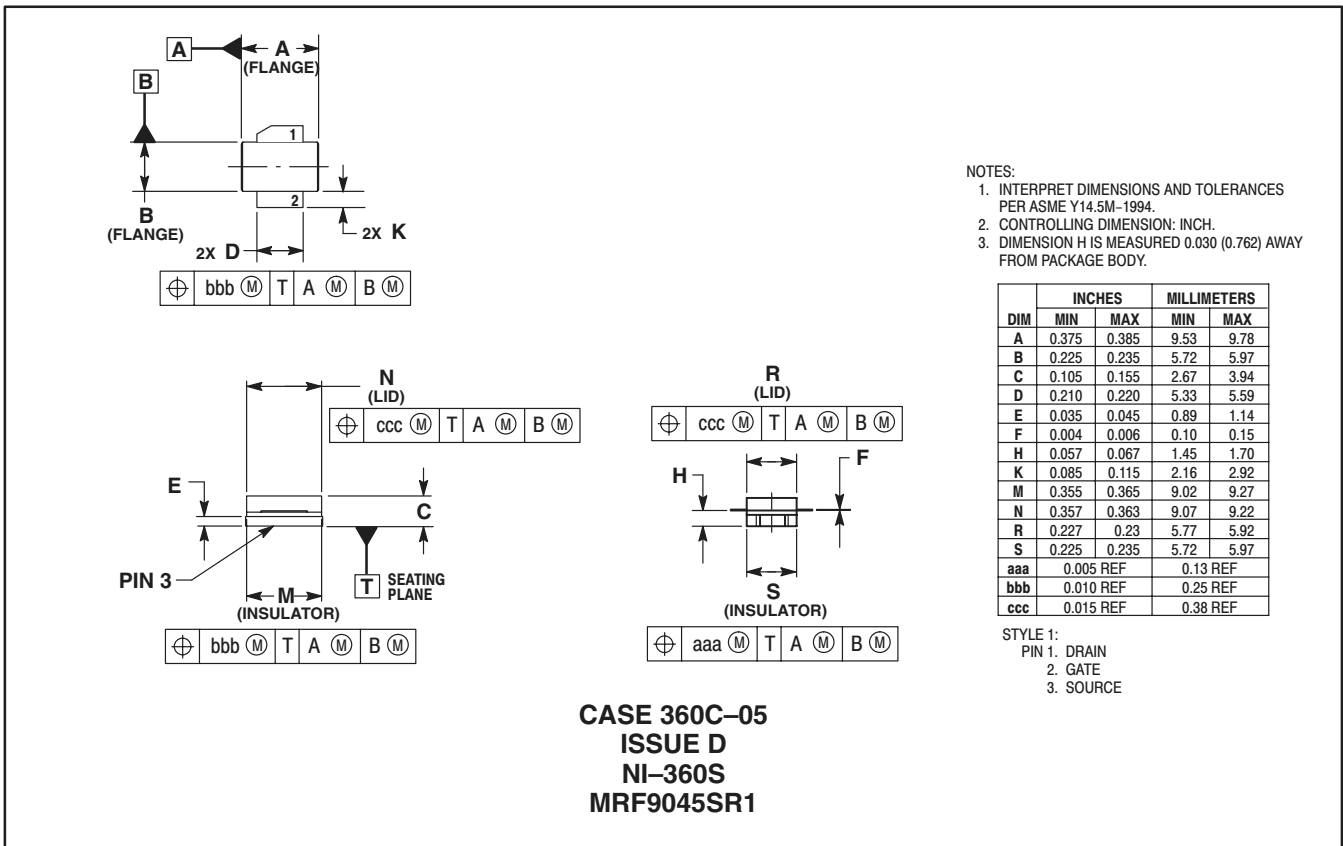
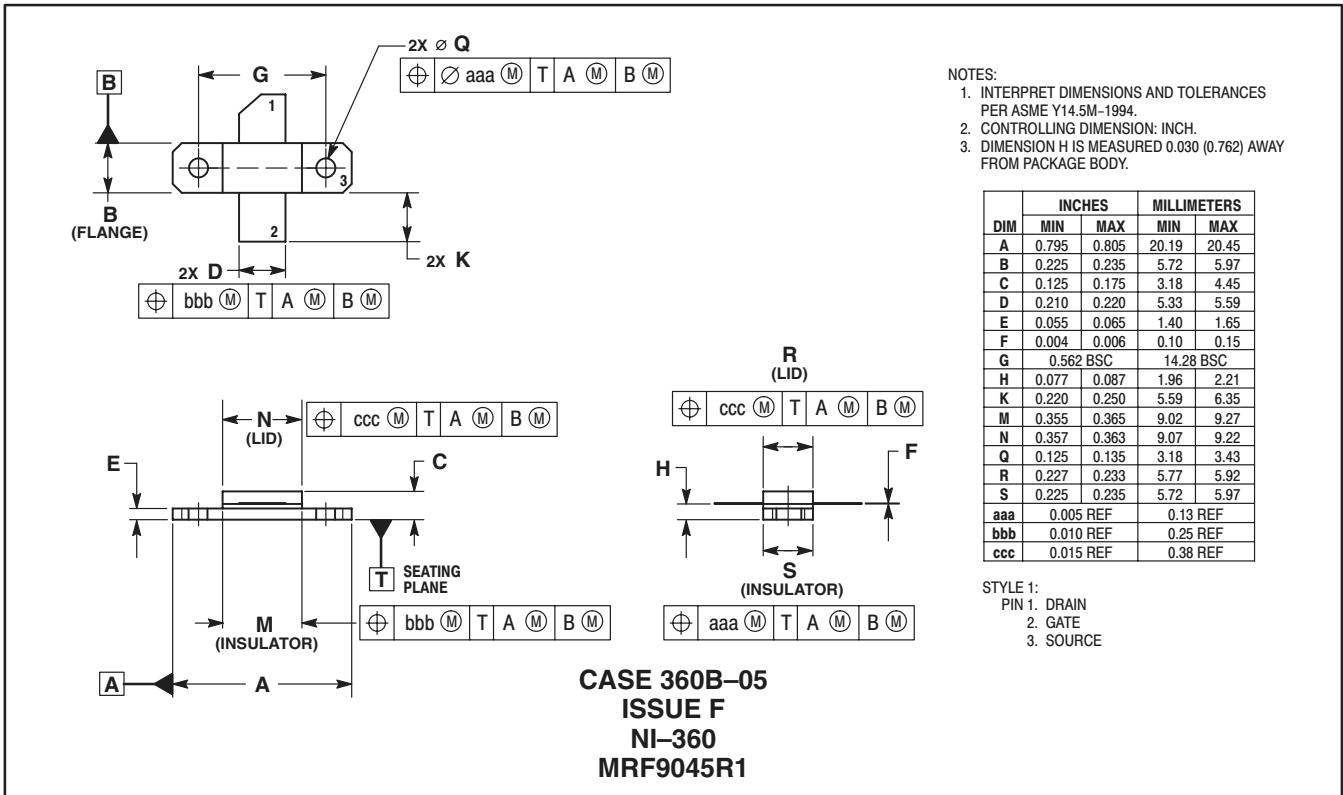

Motorola reserves the right to make changes without further notice to any products herein. Motorola makes no warranty, representation or guarantee regarding the suitability of its products for any particular purpose, nor does Motorola assume any liability arising out of the application or use of any product or circuit, and specifically disclaims any and all liability, including without limitation consequential or incidental damages. "Typical" parameters which may be provided in Motorola data sheets and/or specifications can and do vary in different applications and actual performance may vary over time. All operating parameters, including "Typicals" must be validated for each customer application by customer's technical experts. Motorola does not convey any license under its patent rights nor the rights of others. Motorola products are not designed, intended, or authorized for use as components in systems intended for surgical implant into the body, or other applications intended to support or sustain life, or for any other application in which the failure of the Motorola product could create a situation where personal injury or death may occur. Should Buyer purchase or use Motorola products for any such unintended or unauthorized application, Buyer shall indemnify and hold Motorola and its officers, employees, subsidiaries, affiliates, and distributors harmless against all claims, costs, damages, and expenses, and reasonable attorney fees arising out of, directly or indirectly, any claim of personal injury or death associated with such unintended or unauthorized use, even if such claim alleges that Motorola was negligent regarding the design or manufacture of the part. Motorola, Inc. Motorola, Inc. is an Equal Opportunity/Affirmative Action Employer. MOTOROLA and the  logo are registered in the US Patent & Trademark Office. All other product or service names are the property of their respective owners.

© Motorola, Inc. 2002.

How to reach us:

USA/EUROPE/Locations Not Listed: Motorola Literature Distribution; P.O. Box 5405, Denver, Colorado 80217. 1-303-675-2140 or 1-800-441-2447

JAPAN: Motorola Japan Ltd.; SPS, Technical Information Center, 3-20-1, Minami-Azabu. Minato-ku, Tokyo 106-8573 Japan. 81-3-3440-3569

ASIA/PACIFIC: Motorola Semiconductors H.K. Ltd.; Silicon Harbour Centre, 2 Dai King Street, Tai Po Industrial Estate, Tai Po, N.T., Hong Kong. 852-26668334

Technical Information Center: 1-800-521-6274

HOME PAGE: <http://www.motorola.com/semiconductors/>

