

**TENTATIVE DATA SHEET**  
**9-16 GHz Low Noise MMIC**
**FEATURES**

- 9-16 GHz BANDWIDTH
- +18.0 dBm TYPICAL OUTPUT POWER
- 14 dB  $\pm$  1.5 dB TYPICAL POWER GAIN
- TWO SECTION, DISTRIBUTED AMPLIFIER
- DUAL BIAS SUPPLY
- 0.3 MICRON RECESSED “MUSHROOM” GATE
- Si<sub>3</sub>N<sub>4</sub> PASSIVATION
- ADVANCED EPITAXIAL HETEROJUNCTION PROFILE PROVIDES EXTRA HIGH POWER EFFICIENCY, AND HIGH RELIABILITY

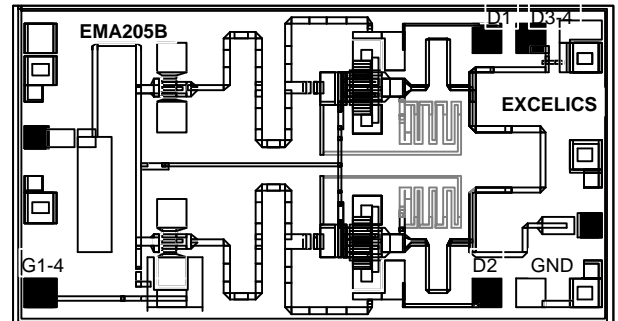

Chip Size 1060 x 2000 microns  
 Chip Thickness: 75  $\pm$  13 microns  
 All Dimensions In Microns

**ELECTRICAL CHARACTERISTICS<sup>1</sup> (T<sub>a</sub> = 25 °C)**

| SYMBOL                                   | PARAMETERS/TEST CONDITIONS           | MIN | TYP       | MAX | UNIT |
|--|--------------------------------------|-----|-----------|-----|------|
| <b>F</b>                                 | Operating Frequency Range            | 9   |           | 16  | GHz  |
| <b>P<sub>1dB</sub></b>                   | Output Power at 1dB Gain Compression |     | 18        |     | dBm  |
| <b>G<sub>ss</sub></b>                    | Small Signal Gain                    |     | 14        |     | dB   |
| <b><math>\Delta</math>G<sub>ss</sub></b> | Small Signal Gain Flatness           |     | $\pm$ 1.5 |     | dB   |
| <b>NF</b>                                | Noise Figure                         |     | 4         |     | dB   |
| <b>VSWR in</b>                           | Input VSWR                           |     | 1.5:1     |     |      |
| <b>VSWR out</b>                          | Output VSWR                          |     | 2.0:1     |     |      |
| <b>I<sub>dd</sub></b>                    | Power Supply Current                 |     | 160       |     | mA   |
| <b>V<sub>dd</sub></b>                    | Power Supply Voltage                 |     | 5         | 8   | V    |

**MAXIMUM RATINGS AT 25°C**

| SYMBOLS                | PARAMETERS              | ABSOLUTE <sup>1</sup> | CONTINUOUS <sup>2</sup> |
|------------------------|-------------------------|-----------------------|-------------------------|
| <b>V<sub>ds</sub></b>  | Drain-Source Voltage    | 12V                   | 8V                      |
| <b>V<sub>gs</sub></b>  | Gate-Source Voltage     | -8V                   | -3V                     |
| <b>I<sub>ds</sub></b>  | Drain Current           | I <sub>dss</sub>      | 225mA                   |
| <b>I<sub>gf</sub></b>  | Forward Gate Current    | 55 mA                 | 9mA                     |
| <b>P<sub>in</sub></b>  | Input Power             | 13dBm                 | @3dB Compression        |
| <b>T<sub>ch</sub></b>  | Channel Temperature     | 175°C                 | 150°C                   |
| <b>T<sub>stg</sub></b> | Storage Temperature     | -65/175°C             | -65/150°C               |
| <b>P<sub>t</sub></b>   | Total Power Dissipation | 1.1 W                 | 900 mW                  |

- Note: 1. Exceeding any of the above ratings may result in permanent damage.  
 2. Exceeding any of the above ratings may reduce MTTF below design goals.

TENTATIVE DATA SHEET  
9-16 GHz Low Noise MMIC

| <b>S-PARAMETERS</b> ( On wafer $S_{ij}$ measurements ) |             |        |             |        |             |        |             |        |  |
|--|-------------|--------|-------------|--------|-------------|--------|-------------|--------|--|
| 5V, 1/2 $I_{dss\_6}$                                   |             |        |             |        |             |        |             |        |  |
| FREQ<br>(GHz)  | --- S11 --- |        | --- S21 --- |        | --- S12 --- |        | --- S22 --- |        |  |
|  | MAG         | ANG    | MAG         | ANG    | MAG         | ANG    | MAG         | ANG    |  |
| 1  | 0.365       | -129.2 | 0.276       | 82.1   | 0.0038      | -28.6  | 0.620       | -112.2 |  |
| 2  | 0.471       | -172.2 | 0.441       | 47.4   | 0.0011      | -88.5  | 0.844       | -167.7 |  |
| 3  | 0.450       | 172.4  | 0.416       | 3.6    | 0.0008      | -125.9 | 0.810       | 158.0  |  |
| 4  | 0.422       | 162.0  | 0.389       | 16.1   | 0.0006      | -139.8 | 0.732       | 130.9  |  |
| 5  | 0.389       | 154.2  | 0.826       | 35.4   | 0.0007      | -175.1 | 0.614       | 104.5  |  |
| 6  | 0.350       | 148.0  | 1.825       | 8.7    | 0.0011      | 160.0  | 0.430       | 73.8   |  |
| 7  | 0.312       | 143.6  | 3.185       | -29.7  | 0.0020      | 139.7  | 0.185       | 34.2   |  |
| 8  | 0.276       | 141.4  | 4.559       | -73.3  | 0.0030      | 97.5   | 0.078       | -139.8 |  |
| 9  | 0.250       | 138.6  | 5.385       | -117.5 | 0.0037      | 58.0   | 0.245       | 168.1  |  |
| 10   | 0.234       | 136.9  | 5.626       | -159.0 | 0.0045      | 18.1   | 0.300       | 137.5  |  |
| 11   | 0.226       | 139.7  | 5.497       | 166.2  | 0.0052      | -10.6  | 0.275       | 115.0  |  |
| 12   | 0.221       | 141.9  | 5.350       | 136.0  | 0.0052      | -34.2  | 0.214       | 99.9   |  |
| 13   | 0.222       | 140.6  | 5.326       | 107.4  | 0.0060      | -54.4  | 0.149       | 95.2   |  |
| 14   | 0.220       | 135.3  | 5.360       | 79.5   | 0.0067      | -76.5  | 0.092       | 109.1  |  |
| 15   | 0.235       | 131.2  | 5.594       | 50.3   | 0.0077      | -103.0 | 0.088       | 149.1  |  |
| 16   | 0.271       | 127.6  | 6.062       | 18.7   | 0.0101      | -130.2 | 0.132       | 172.4  |  |
| 17   | 0.385       | 119.2  | 6.709       | -17.2  | 0.0122      | -160.7 | 0.205       | 176.3  |  |
| 18   | 0.511       | 89.3   | 6.771       | -59.4  | 0.0122      | 160.1  | 0.314       | 172.1  |  |
| 19   | 0.577       | 53.6   | 5.973       | -105.7 | 0.0111      | 115.1  | 0.457       | 159.6  |  |
| 20   | 0.577       | 21.6   | 4.309       | -151.4 | 0.0072      | 74.4   | 0.608       | 141.4  |  |
| 21   | 0.564       | -2.5   | 2.567       | 171.8  | 0.0022      | 33.0   | 0.711       | 119.8  |  |
| 22   | 0.589       | -23.7  | 1.423       | 155.1  | 0.0004      | 127.1  | 0.733       | 98.4   |  |
| 23   | 0.606       | -42.8  | 1.095       | 146.8  | 0.0018      | 108.7  | 0.686       | 81.3   |  |
| 24   | 0.623       | -58.4  | 0.917       | 130.5  | 0.0021      | 87.5   | 0.628       | 69.0   |  |
| 25   | 0.6426      | -70.4  | 0.754       | 112.2  | 0.0023      | 72.2   | 0.585       | 59.3   |  |
| 26   | 0.664       | -79.7  | 0.607       | 94.3   | 0.0027      | 75.1   | 0.555       | 50.8   |  |
| 27   | 0.694       | -88.2  | 0.487       | 76.6   | 0.0031      | 76.8   | 0.531       | 42.8   |  |
| 28   | 0.732       | -98.1  | 0.399       | 58.6   | 0.0026      | 68.9   | 0.511       | 34.9   |  |
| 29   | 0.761       | -106.2 | 0.330       | 41.6   | 0.0015      | 58.9   | 0.496       | 27.0   |  |
| 30   | 0.791       | -114.1 | 0.271       | 24.2   | 0.0014      | 23.6   | 0.480       | 19.1   |  |

## TENTATIVE DATA SHEET 9-16 GHz Low Noise MMIC

### ASSEMBLY DRAWING

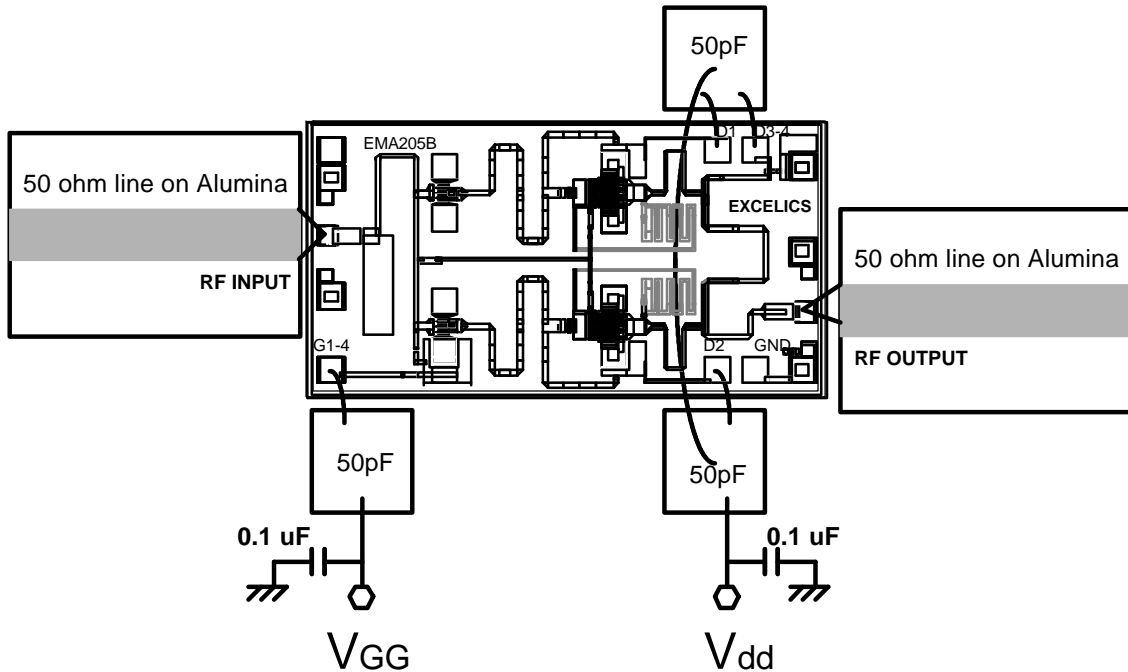

The length of RF wires should be as short as possible. Use at least two wires between RF pad and 50 ohm line and separate the wires to minimize the mutual inductance.

### CHIP OUTLINE

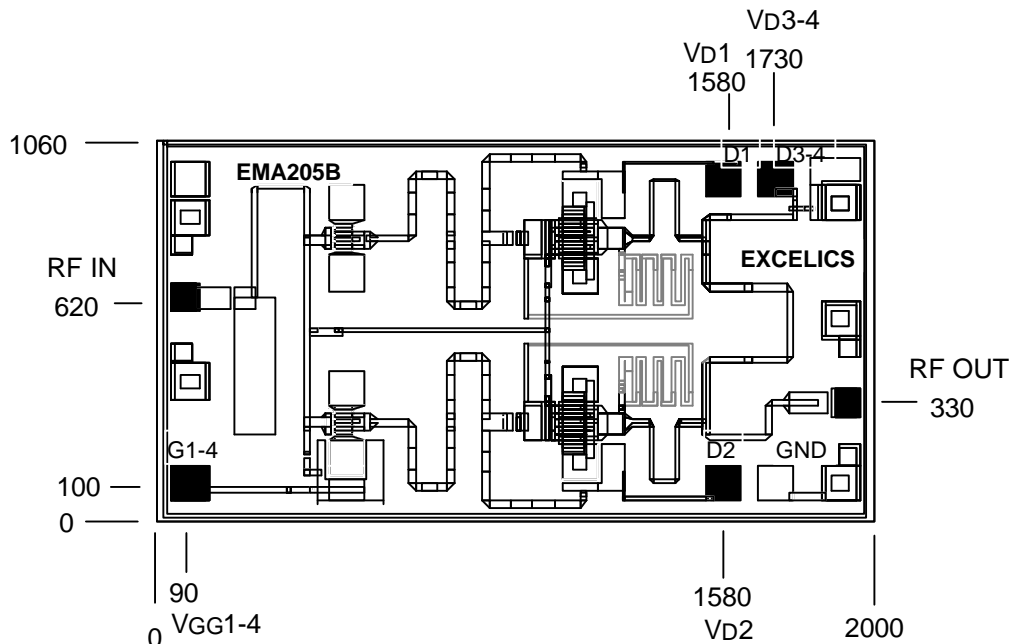

Chip Size 1060 x 2000 microns  
 Chip Thickness: 75 ± 13 microns  
 PAD Dimensions: 1. DC 100 x 100 microns  
 2. RF 80 x 68 microns  
 All Dimensions In Microns

## TENTATIVE DATA SHEET 9-16 GHz Low Noise MMIC

### TYPICAL APPLICATION PERFORMANCE

