

# 54AC/74AC191 Up/Down Counter with Preset and Ripple Clock

## General Description

The 'AC191 is a reversible modulo 16 binary counter. It features synchronous counting and asynchronous presetting. The preset feature allows the 'AC191 to be used in programmable dividers. The Count Enable input, the Terminal Count output and the Ripple Clock output make possible a variety of methods of implementing multistage counters. In the counting modes, state changes are initiated by the rising edge of the clock.

## Features

- I<sub>CC</sub> reduced by 50%
- High speed—133 MHz typical count frequency
- Synchronous counting
- Asynchronous parallel load
- Cascadable
- Outputs source/sink 24 mA
- Standard Military Drawing (SMD)  
— 'AC191: 5962-89749

## Logic Symbols

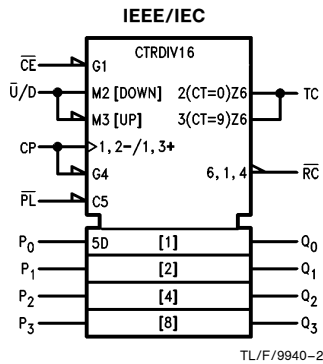
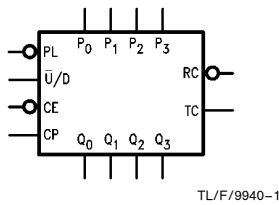

## Connection Diagrams

Pin Assignment for DIP, Flatpak and SOIC

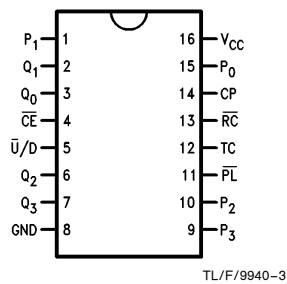

Pin Assignment for LCC

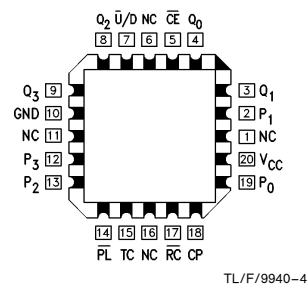

Pin Names	Description
$\overline{CE}$	Count Enable Input
CP	Clock Pulse Input
P <sub>0</sub> -P <sub>3</sub>	Parallel Data Inputs
$\overline{PL}$	Asynchronous Parallel Load Input
$\overline{U/D}$	Up/Down Count Control Input
Q <sub>0</sub> -Q <sub>3</sub>	Flip-Flop Outputs
$\overline{RC}$	Ripple Clock Output
TC	Terminal Count Output

FACT™ is a trademark of National Semiconductor Corporation.

## Functional Description

The 'AC191 is a synchronous up/down counter. The 'AC191 is organized as a 4-bit binary counter. It contains four edge-triggered flip-flops with internal gating and steering logic to provide individual preset, count-up and count-down operations.

Each circuit has an asynchronous parallel load capability permitting the counter to be preset to any desired number. When the Parallel Load ( $\overline{PL}$ ) input is LOW, information present on the Parallel Load inputs ( $P_0$ – $P_3$ ) is loaded into the counter and appears on the Q outputs. This operation overrides the counting functions, as indicated in the Mode Select Table.

A HIGH signal on the  $\overline{CE}$  input inhibits counting. When  $\overline{CE}$  is LOW, internal state changes are initiated synchronously by the LOW-to-HIGH transition of the clock input. The direction of counting is determined by the  $\overline{U/D}$  input signal, as indicated in the Mode Select Table.  $\overline{CE}$  and  $\overline{U/D}$  can be changed with the clock in either state, provided only that the recommended setup and hold times are observed.

Two types of outputs are provided as overflow/underflow indicators. The terminal count (TC) output is normally LOW. It goes HIGH when the circuits reach zero in the count down mode or 15 in the count up mode. The TC output will then remain HIGH until a state change occurs, whether by counting or presetting or until  $\overline{U/D}$  is changed. The TC output should not be used as a clock signal because it is subject to decoding spikes.

The TC signal is also used internally to enable the Ripple Clock ( $\overline{RC}$ ) output. The  $\overline{RC}$  output is normally HIGH. When  $\overline{CE}$  is LOW and TC is HIGH,  $\overline{RC}$  output will go LOW when the clock next goes LOW and will stay LOW until the clock goes HIGH again. This feature simplifies the design of multistage counters, as indicated in Figures A and B. In Figure A, each  $\overline{RC}$  output is used as the clock input for the next higher stage. This configuration is particularly advantageous when the clock source has a limited drive capability, since it drives only the first stage. To prevent counting in all stages it is only necessary to inhibit the first stage, since a HIGH signal on  $\overline{CE}$  inhibits the  $\overline{RC}$  output pulse, as indicated in the  $\overline{RC}$  Truth Table. A disadvantage of this configuration, in some applications, is the timing skew between state changes in the first and last stages. This represents the cumulative delay of the clock as it ripples through the preceding stages.

A method of causing state changes to occur simultaneously in all stages is shown in Figure B. All clock inputs are driven in parallel and the  $\overline{RC}$  outputs propagate the carry/borrow signals in ripple fashion. In this configuration the LOW state duration of the clock must be long enough to allow the negative-going edge of the carry/borrow signal to ripple through to the last stage before the clock goes HIGH. There is no such restriction on the HIGH state duration of the clock, since the  $\overline{RC}$  output of any device goes HIGH shortly after its CP input goes HIGH.

The configuration shown in Figure C avoids ripple delays and their associated restrictions. The  $\overline{CE}$  input for a given stage is formed by combining the TC signals from all the preceding stages. Note that in order to inhibit counting an enable signal must be included in each carry gate. The simple inhibit scheme of Figures A and B doesn't apply, because the TC output of a given stage is not affected by its own  $\overline{CE}$ .

Mode Select Table

Inputs				Mode
$\overline{PL}$	$\overline{CE}$	$\overline{U/D}$	CP	
H	L	L	↗	Count Up
H	L	H	↘	Count Down
L	X	X	X	Preset (Asyn.)
H	H	X	X	No Change (Hold)

## $\overline{RC}$ Truth Table

Inputs				Outputs
$\overline{PL}$	$\overline{CE}$	TC*	CP	$\overline{RC}$
H	L	H	↘	↘
H	H	X	X	H
H	X	L	X	H
L	X	X	X	H

\*TC is generated internally  
H = HIGH Voltage Level  
L = LOW Voltage Level  
X = Immaterial  
↗ = LOW-to-HIGH Transition

## State Diagram

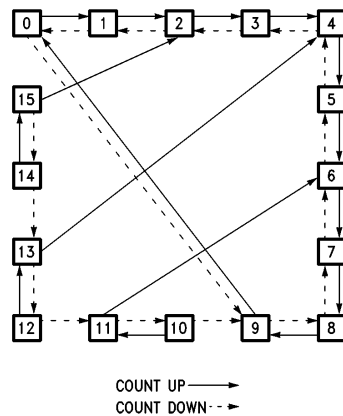

TL/F/9940-5

## Functional Description (Continued)

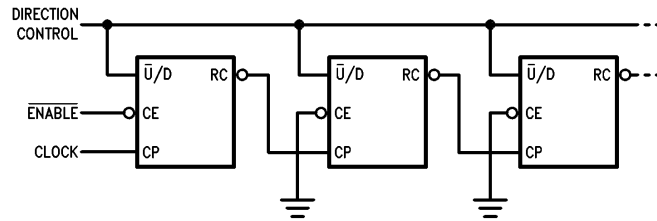

FIGURE A. N-Stage Counter Using Ripple Clock

TL/F/9940-7

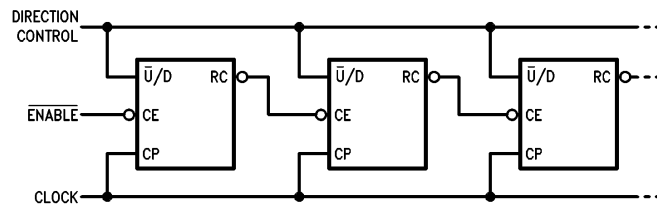

FIGURE B. Synchronous N-Stage Counter Using Ripple Carry/Borrow

TL/F/9940-8

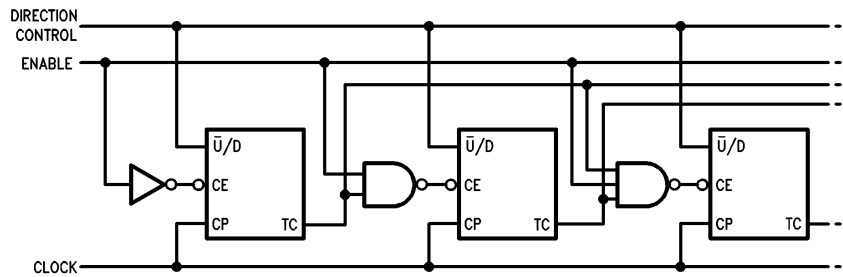
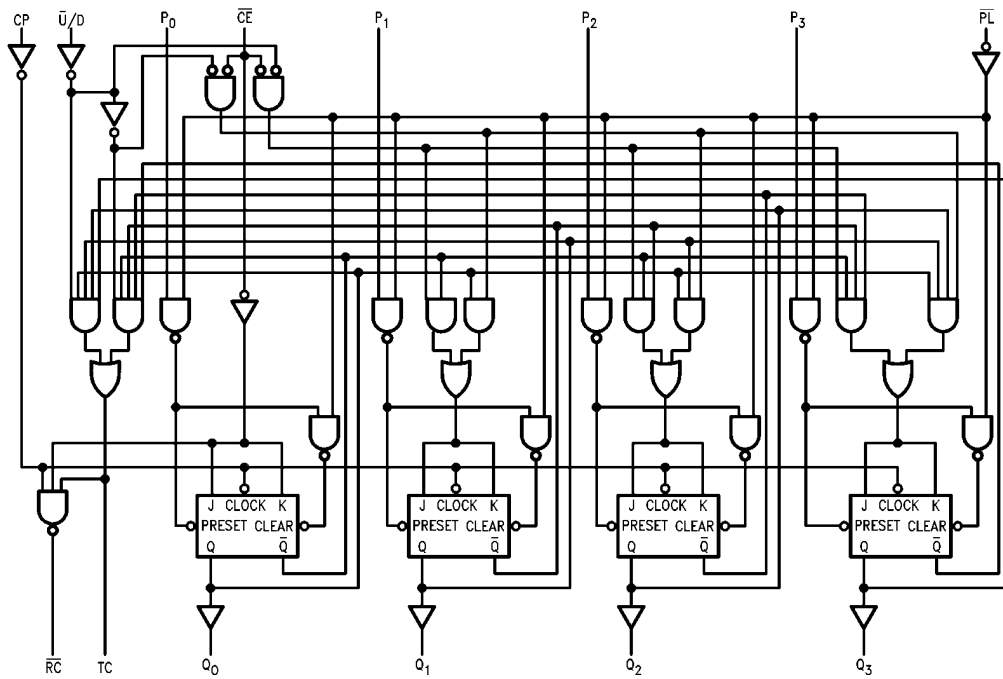

FIGURE C. Synchronous N-Stage Counter with Parallel Gated Carry/Borrow

TL/F/9940-9

# Logic Diagram



TL/F/9940-6

Please note that this diagram is provided only for the understanding of logic operations and should not be used to estimate propagation delays.

## Absolute Maximum Ratings (Note 1)

If Military/Aerospace specified devices are required, please contact the National Semiconductor Sales Office/Distributors for availability and specifications.

Supply Voltage ( $V_{CC}$ )	-0.5V to +7.0V
DC Input Diode Current ( $I_{IK}$ )	
$V_I = -0.5V$	-20 mA
$V_I = V_{CC} + 0.5V$	+20 mA
DC Input Voltage ( $V_I$ )	-0.5V to $V_{CC} + 0.5V$
DC Output Diode Current ( $I_{OK}$ )	
$V_O = -0.5V$	-20 mA
$V_O = V_{CC} + 0.5V$	+20 mA
DC Output Voltage ( $V_O$ )	-0.5V to $V_{CC} + 0.5V$
DC Output Source or Sink Current ( $I_O$ )	±50 mA
DC $V_{CC}$ or Ground Current per Output Pin ( $I_{CC}$ or $I_{GND}$ )	±50 mA
Storage Temperature ( $T_{STG}$ )	-65°C to +150°C
Junction Temperature ( $T_J$ )	
CDIP	175°C
PDIP	140°C

**Note 1:** Absolute maximum ratings are those values beyond which damage to the device may occur. The databook specifications should be met, without exception, to ensure that the system design is reliable over its power supply, temperature, output/input loading variables. National does not recommend operation of FACT™ circuits outside databook specifications.

## Recommended Operating Conditions

Supply Voltage ( $V_{CC}$ )	2.0V to 6.0V
Input Voltage ( $V_I$ )	0V to $V_{CC}$
Output Voltage ( $V_O$ )	0V to $V_{CC}$
Operating Temperature ( $T_A$ )	
74AC	-40°C to +85°C
54AC	-55°C to +125°C
Minimum Input Edge Rate ( $\Delta V/\Delta t$ )	
'AC Devices	
$V_{IN}$ from 30% to 70% of $V_{CC}$	
$V_{CC}$ @ 3.3V, 4.5V, 5.5V	125 mV/ns

## DC Characteristics for 'AC Family Devices

Symbol	Parameter	$V_{CC}$ (V)	74AC		54AC	74AC	Units	Conditions	
			$T_A = +25^\circ\text{C}$		$T_A = -55^\circ\text{C to } +125^\circ\text{C}$	$T_A = -40^\circ\text{C to } +85^\circ\text{C}$			
			Typ	Guaranteed Limits					
$V_{IH}$	Minimum High Level Input Voltage	3.0	1.5	2.1	2.1	2.1	V	$V_{OUT} = 0.1V$ or $V_{CC} - 0.1V$	
		4.5	2.25	3.15	3.15	3.15			
		5.5	2.75	3.85	3.85	3.85			
$V_{IL}$	Maximum Low Level Input Voltage	3.0	1.5	0.9	0.9	0.9	V	$V_{OUT} = 0.1V$ or $V_{CC} - 0.1V$	
		4.5	2.25	1.35	1.35	1.35			
		5.5	2.75	1.65	1.65	1.65			
$V_{OH}$	Minimum High Level Output Voltage	3.0	2.99	2.9	2.9	2.9	V	$I_{OUT} = -50 \mu\text{A}$	
		4.5	4.49	4.4	4.4	4.4			
		5.5	5.49	5.4	5.4	5.4			
			3.0		2.56	2.4	2.46	V	* $V_{IN} = V_{IL}$ or $V_{IH}$ -12 mA $I_{OH}$ -24 mA -24 mA
			4.5		3.86	3.7	3.76		
			5.5		4.86	4.7	4.76		
$V_{OL}$	Maximum Low Level Output Voltage	3.0	0.002	0.1	0.1	0.1	V	$I_{OUT} = 50 \mu\text{A}$	
		4.5	0.001	0.1	0.1	0.1			
		5.5	0.001	0.1	0.1	0.1			
			3.0		0.36	0.50	0.44	V	* $V_{IN} = V_{IL}$ or $V_{IH}$ 12 mA $I_{OL}$ 24 mA 24 mA
			4.5		0.36	0.50	0.44		
			5.5		0.36	0.50	0.44		
$I_{IN}$	Maximum Input Leakage Current	5.5		±0.1	±1.0	±1.0	μA	$V_I = V_{CC}, \text{GND}$	

\*All outputs loaded; thresholds on input associated with output under test.

## DC Characteristics for 'AC Family Devices (Continued)

Symbol	Parameter	V <sub>CC</sub> (V)	74AC		54AC		74AC		Units	Conditions
			T <sub>A</sub> = +25°C		T <sub>A</sub> = -55°C to +125°C		T <sub>A</sub> = -40°C to +85°C			
			Typ	Guaranteed Limits						
I <sub>OLD</sub>	†Minimum Dynamic Output Current	5.5			50		75		mA	V <sub>OLD</sub> = 1.65V Max
I <sub>OHD</sub>		5.5			-50		-75		mA	V <sub>OHD</sub> = 3.85V Min
I <sub>CC</sub>	Maximum Quiescent Supply Current	5.5		4.0	80.0		40.0		μA	V <sub>IN</sub> = V <sub>CC</sub> or GND

†Maximum test duration 2.0 ms, one output loaded at a time.

**Note:** I<sub>N</sub> and I<sub>CC</sub> @ 3.0V are guaranteed to be less than or equal to the respective limit @ 5.5V V<sub>CC</sub>.  
I<sub>CC</sub> for 54AC @ 25°C is identical to 74AC @ 25°C.

## AC Electrical Characteristics

Symbol	Parameter	V <sub>CC</sub> * (V)	74AC			54AC		74AC		Units
			T <sub>A</sub> = +25°C C <sub>L</sub> = 50 pF			T <sub>A</sub> = -55°C to +125°C C <sub>L</sub> = 50 pF		T <sub>A</sub> = -40°C to +85°C C <sub>L</sub> = 50 pF		
			Min	Typ	Max	Min	Max	Min	Max	
f <sub>max</sub>	Maximum Count Frequency	3.3 5.0	70 90	105 133		55 80		65 85	MHz	
t <sub>PLH</sub>	Propagation Delay CP to Q <sub>n</sub>	3.3 5.0	2.0 1.5	8.5 6.0	15.0 11.0	1.0 1.0	16.5 12.0	1.5 1.5	16.0 12.0	ns
t <sub>PHL</sub>	Propagation Delay CP to Q <sub>n</sub>	3.3 5.0	2.5 1.5	8.5 6.0	14.5 10.5	1.0 1.0	16.0 12.0	2.0 1.5	16.0 11.5	ns
t <sub>PLH</sub>	Propagation Delay CP to TC	3.3 5.0	3.5 2.5	10.5 7.5	18.0 12.0	1.0 1.0	19.5 14.0	2.5 1.5	20.0 14.0	ns
t <sub>PHL</sub>	Propagation Delay CP to TC	3.3 5.0	4.0 2.5	10.5 7.5	17.5 12.5	1.0 1.0	19.0 14.5	3.0 2.0	19.0 13.5	ns
t <sub>PLH</sub>	Propagation Delay CP to RC	3.3 5.0	2.5 2.0	7.5 5.5	12.0 9.5	1.0 1.0	14.0 10.5	2.0 1.0	13.5 10.5	ns
t <sub>PHL</sub>	Propagation Delay CP to RC	3.3 5.0	2.5 1.5	7.0 5.0	11.5 8.5	1.0 1.0	12.5 9.5	2.0 1.0	12.5 9.5	ns
t <sub>PLH</sub>	Propagation Delay CE to RC	3.3 5.0	2.5 1.5	7.0 5.0	12.0 8.5	1.0 1.0	14.0 10.0	1.5 1.0	13.5 9.5	ns
t <sub>PHL</sub>	Propagation Delay CE to RC	3.3 5.0	2.0 1.5	6.5 5.0	11.0 8.0	1.0 1.0	12.5 9.5	1.5 1.0	12.5 9.0	ns
t <sub>PLH</sub>	Propagation Delay U/D to RC	3.3 5.0	2.5 1.5	6.5 5.0	12.5 9.0	1.0 1.0	14.5 11.0	2.0 1.0	14.5 10.0	ns
t <sub>PHL</sub>	Propagation Delay U/D to RC	3.3 5.0	2.5 1.5	7.0 5.0	12.0 8.5	1.0 1.0	15.0 11.0	2.0 1.0	13.5 10.0	ns
t <sub>PLH</sub>	Propagation Delay U/D to TC	3.3 5.0	2.0 1.5	7.0 5.0	11.5 8.5	1.0 1.0	14.0 10.5	1.5 1.0	13.5 9.5	ns
t <sub>PHL</sub>	Propagation Delay U/D to TC	3.3 5.0	2.0 1.5	6.5 5.0	11.0 8.5	1.0 1.0	13.5 10.0	1.5 1.0	12.5 9.5	ns
t <sub>PLH</sub>	Propagation Delay P <sub>n</sub> to Q <sub>n</sub>	3.3 5.0	2.5 2.0	8.0 5.5	13.5 9.5	1.0 1.0	16.5 11.5	2.0 1.0	15.5 10.5	ns

\*Voltage Range 3.3 is 3.3V ±0.3V  
Voltage Range 5.0 is 5.0V ±0.5V

## AC Electrical Characteristics

Symbol	Parameter	V <sub>CC</sub> * (V)	74AC			54AC		74AC		Units
			T <sub>A</sub> = +25°C C <sub>L</sub> = 50 pF			T <sub>A</sub> = -55°C to +125°C C <sub>L</sub> = 50 pF		T <sub>A</sub> = -40°C to +85°C C <sub>L</sub> = 50 pF		
			Min	Typ	Max	Min	Max	Min	Max	
t <sub>PHL</sub>	Propagation Delay P <sub>n</sub> to Q <sub>n</sub>	3.3	2.5	7.5	13.0	1.0	15.5	1.5	14.5	ns
		5.0	1.5	5.5	9.5	1.0	10.5	1.0	10.5	
t <sub>PLH</sub>	Propagation Delay P <sub>L</sub> to Q <sub>n</sub>	3.3	3.5	9.5	14.5	1.0	18.0	2.5	17.5	ns
		5.0	2.0	5.5	9.5	1.0	12.5	1.0	10.5	
t <sub>PHL</sub>	Propagation Delay P <sub>L</sub> to Q <sub>n</sub>	3.3	3.0	8.0	13.5	1.0	15.5	2.0	15.5	ns
		5.0	2.0	6.0	10.0	1.0	11.5	1.5	11.0	

\*Voltage Range 3.3 is 3.3V ±0.3V  
Voltage Range 5.0 is 5.0V ±0.5V

## AC Operating Requirements

Symbol	Parameter	V <sub>CC</sub> * (V)	74AC		54AC	74AC		Units
			T <sub>A</sub> = +25°C C <sub>L</sub> = 50 pF		T <sub>A</sub> = -55°C to +125°C C <sub>L</sub> = 50 pF	T <sub>A</sub> = -40°C to +85°C C <sub>L</sub> = 50 pF		
			Typ	Guaranteed Minimum				
t <sub>s</sub>	Setup Time, HIGH or LOW P <sub>n</sub> to P <sub>L</sub>	3.3	1.0	3.0	4.0	3.0	3.0	ns
		5.0	0.5	2.0	3.0	2.5	2.5	
t <sub>h</sub>	Hold Time, HIGH or LOW P <sub>n</sub> to P <sub>L</sub>	3.3	-1.5	0.5	1.5	1.0	1.0	ns
		5.0	-0.5	1.0	2.0	1.0	1.0	
t <sub>s</sub>	Setup Time, LOW C <sub>E</sub> to CP	3.3	3.0	6.0	9.0	7.0	7.0	ns
		5.0	1.5	4.0	6.0	4.5	4.5	
t <sub>h</sub>	Hold Time, LOW C <sub>E</sub> to CP	3.3	-4.0	-0.5	0	-0.5	-0.5	ns
		5.0	-2.5	0	0.5	0	0	
t <sub>s</sub>	Setup Time, HIGH or LOW U/D to CP	3.3	4.0	8.0	10.5	9.0	9.0	ns
		5.0	2.5	5.5	7.5	6.5	6.5	
t <sub>h</sub>	Hold Time, HIGH or LOW U/D to CP	3.3	-5.0	0	0	0	0	ns
		5.0	-3.0	0.5	1.0	0.5	0.5	
t <sub>w</sub>	P <sub>L</sub> Pulse Width, LOW	3.3	2.0	3.5	5.0	4.0	4.0	ns
		5.0	1.0	1.0	5.0	1.0	1.0	
t <sub>w</sub>	CP Pulse Width, LOW	3.3	2.0	3.5	6.0	4.0	4.0	ns
		5.0	2.0	3.0	6.0	4.0	4.0	
t <sub>rec</sub>	Recovery Time P <sub>L</sub> to CP	3.3	-0.5	0	1.5	0	0	ns
		5.0	-1.0	0	1.0	0	0	

\*Voltage Range 3.3 is 3.3V ±0.3V  
Voltage Range 5.0 is 5.0V ±0.5V

## Capacitance

Symbol	Parameter	Typ	Units	Conditions
C <sub>IN</sub>	Input Capacitance	4.5	pF	V <sub>CC</sub> = OPEN
C <sub>PD</sub>	Power Dissipation Capacitance	75.0	pF	V <sub>CC</sub> = 5.0V

## Ordering Information

The device number is used to form part of a simplified purchasing code where the package type and temperature range are defined as follows:

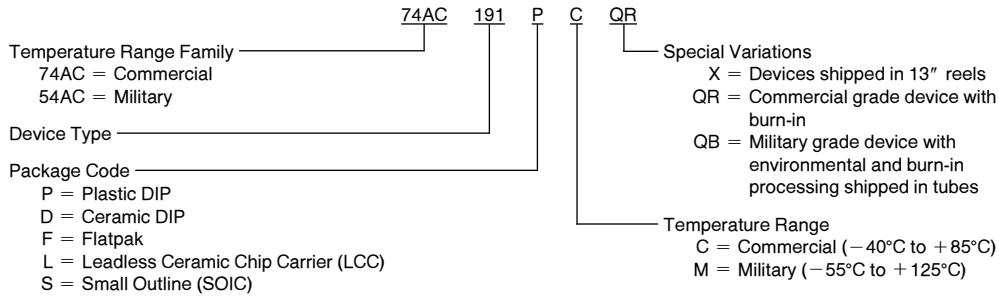

## Physical Dimensions inches (millimeters)

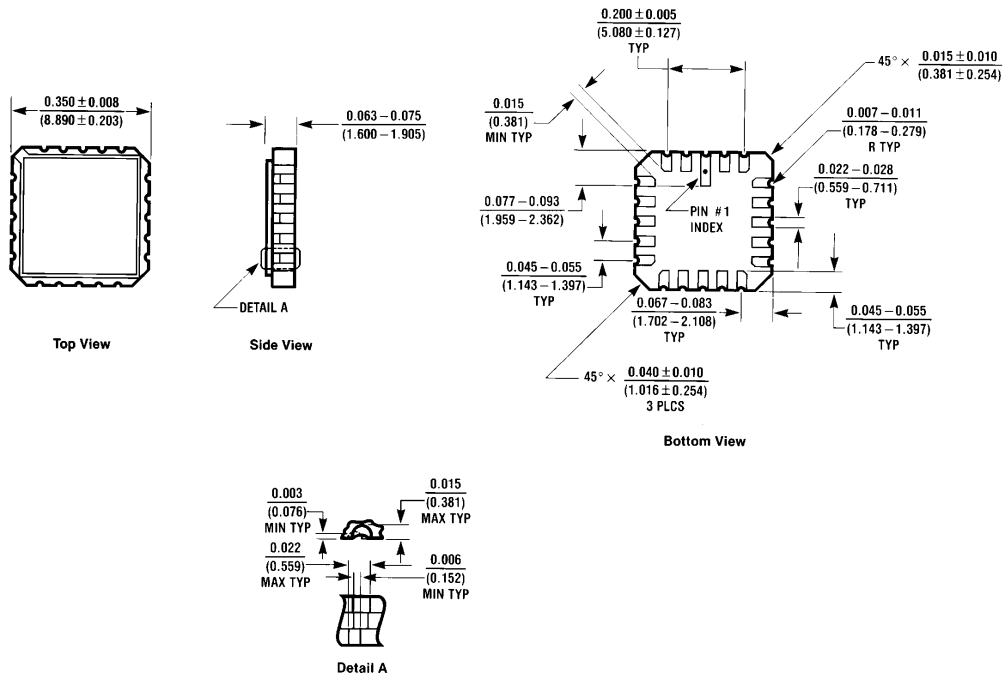

**20 Terminal Ceramic Leadless Chip Carrier (L)  
NS Package Number E20A**

E20A (REV D)

**Physical Dimensions** inches (millimeters) (Continued)

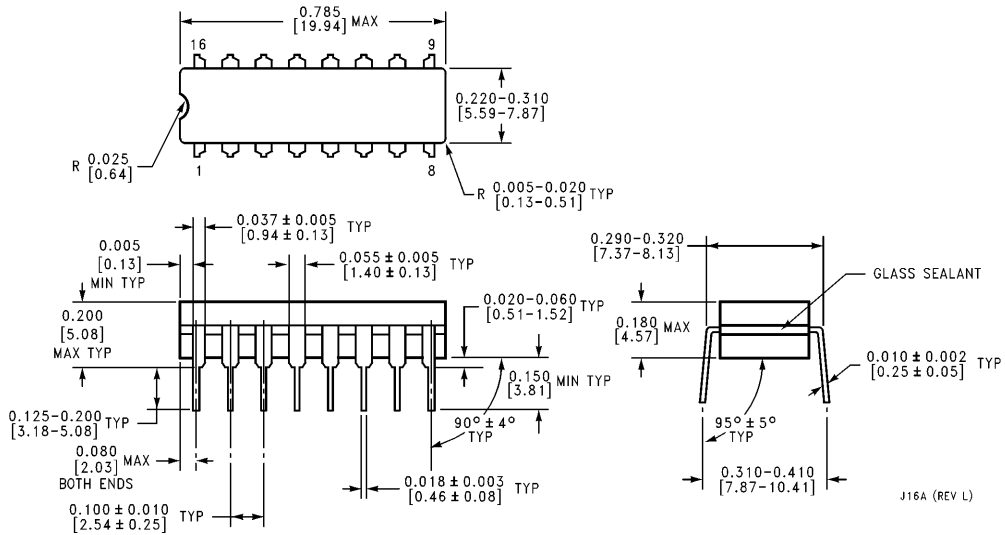

**16 Lead Ceramic Dual-In-Line Package (D)  
 NS Package Number J16A**

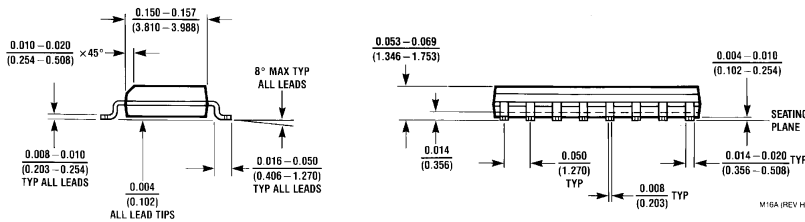
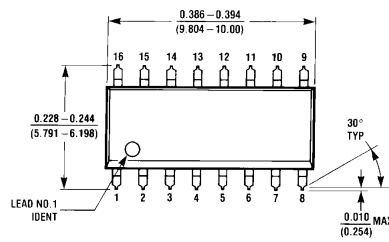

**16 Lead Small Outline Ingrated Circuit (S)  
 NS Package Number M16A**

**Physical Dimensions** inches (millimeters) (Continued)

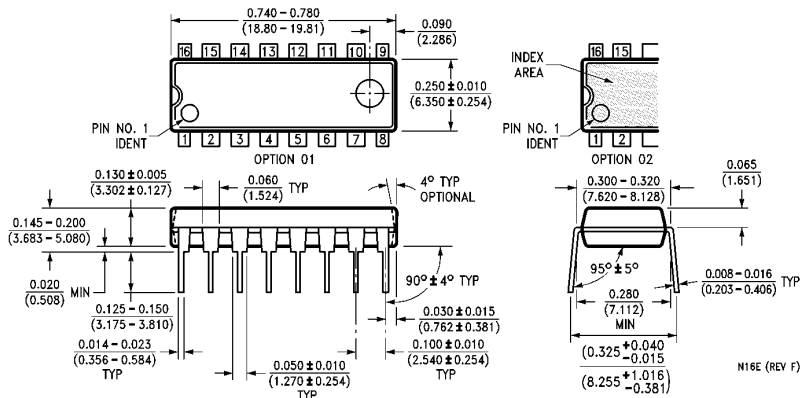

**16 Lead Plastic Dual-In-Line Package (P)**  
NS Package Number N16E

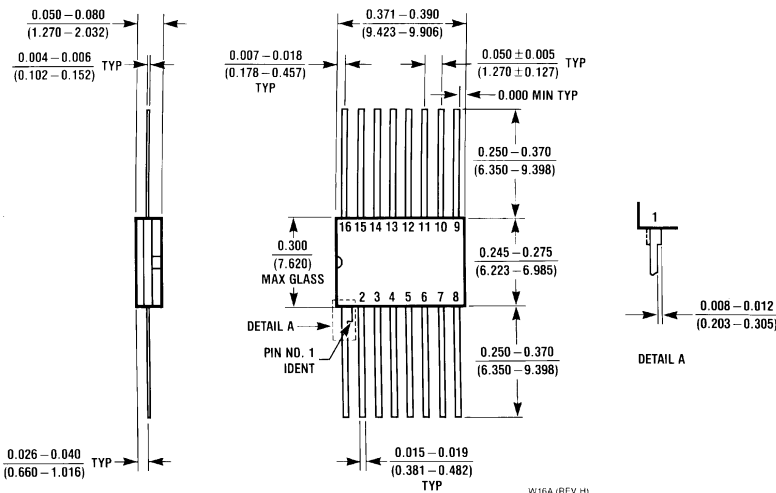

**16 Lead Ceramic Flatpak (F)**  
NS Package Number W16A

**LIFE SUPPORT POLICY**

NATIONAL'S PRODUCTS ARE NOT AUTHORIZED FOR USE AS CRITICAL COMPONENTS IN LIFE SUPPORT DEVICES OR SYSTEMS WITHOUT THE EXPRESS WRITTEN APPROVAL OF THE PRESIDENT OF NATIONAL SEMICONDUCTOR CORPORATION. As used herein:

1. Life support devices or systems are devices or systems which, (a) are intended for surgical implant into the body, or (b) support or sustain life, and whose failure to perform, when properly used in accordance with instructions for use provided in the labeling, can be reasonably expected to result in a significant injury to the user.
2. A critical component is any component of a life support device or system whose failure to perform can be reasonably expected to cause the failure of the life support device or system, or to affect its safety or effectiveness.

 <p><b>National Semiconductor Corporation</b> 2900 Semiconductor Drive P.O. Box 58090 Santa Clara, CA 95052-8090 Tel: 1(800) 272-9959 TWX: (910) 339-9240</p>	<p><b>National Semiconductor GmbH</b> Livny-Gargan-Str. 10 D-82256 Fürstenfeldbruck Germany Tel: (81-41) 35-0 Telex: 527849 Fax: (81-41) 35-1</p>	<p><b>National Semiconductor Japan Ltd.</b> Sumitomo Chemical Engineering Center Bldg. 7F 1-7-1, Nakase, Mihama-Ku Chiba-City, Ciba Prefecture 261 Tel: (043) 299-2300 Fax: (043) 299-2500</p>	<p><b>National Semiconductor Hong Kong Ltd.</b> 13th Floor, Straight Block, Ocean Centre, 5 Canton Rd. Tsimshatsui, Kowloon Hong Kong Tel: (852) 2737-1600 Fax: (852) 2736-9960</p>	<p><b>National Semicondutores Do Brazil Ltda.</b> Rue Deputado Lacorda Franco 120-3A Sao Paulo-SP Brazil 05418-000 Tel: (55-11) 212-5066 Telex: 391-1131931 NSBR BR Fax: (55-11) 212-1181</p>	<p><b>National Semiconductor (Australia) Pty. Ltd.</b> Building 16 Business Park Drive Monash Business Park Nottingham, Melbourne Victoria 3168 Australia Tel: (3) 558-9999 Fax: (3) 558-9998</p>
--	---	--	---	---	---

National does not assume any responsibility for use of any circuitry described, no circuit patent licenses are implied and National reserves the right at any time without notice to change said circuitry and specifications.