

# 54AC244/54ACT244

## Octal Buffer/Line Driver with TRI-STATE® Outputs

### General Description

The 'AC/'ACT244 is an octal buffer and line driver designed to be employed as a memory address driver, clock driver and bus-oriented transmitter/receiver which provides improved PC board density.

### Features

- $I_{CC}$  and  $I_{OZ}$  reduced by 50%
- TRI-STATE outputs drive bus lines or buffer memory address registers

- Outputs source/sink 24 mA
- 'ACT244 has TTL-compatible inputs
- Standard Microcircuit Drawing (SMD)
  - 'AC244: 5962-87552
  - 'ACT244: 5962-87760
- 54AC244 now qualified to 300Krad RHA designation, refer to the SMD for more information

### Logic Symbol

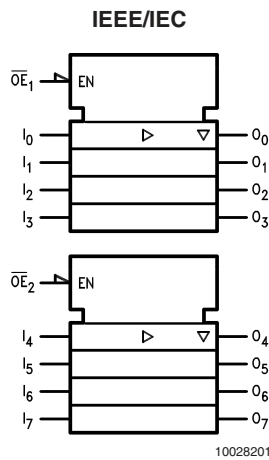

Pin Names	Description
$\overline{OE}_1, \overline{OE}_2$	TRI-STATE Output Enable Inputs
$I_0-I_7$	Inputs
$O_0-O_7$	Outputs

TRI-STATE® is a registered trademark of National Semiconductor Corporation.  
 FACT® is a registered trademark of Fairchild Semiconductor Corporation.

## Connection Diagrams

Pin Assignment for DIP and Flatpak

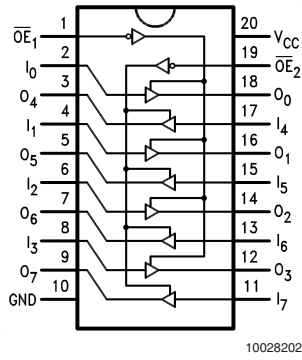

Pin Assignment for LCC

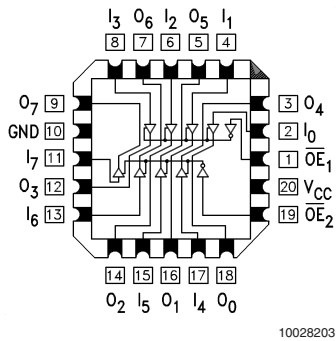

## Truth Tables

Inputs		Outputs (Pins 12, 14, 16, 18)
$\overline{OE}_1$	$I_n$	
L	L	L
L	H	H
H	X	Z

H = HIGH Voltage Level  
L = LOW Voltage Level

Inputs		Outputs (Pins 3, 5, 7, 9)
$\overline{OE}_2$	$I_n$	
L	L	L
L	H	H
H	X	Z

X = Immaterial  
Z = High Impedance

**Absolute Maximum Ratings** (Note 1)

If Military/Aerospace specified devices are required, please contact the National Semiconductor Sales Office/Distributors for availability and specifications.

Supply Voltage ( $V_{CC}$ )	-0.5V to +7.0V
DC Input Diode Current ( $I_{IK}$ )	
$V_I = -0.5V$	-20 mA
$V_I = V_{CC} + 0.5V$	+20 mA
DC Input Voltage ( $V_I$ )	-0.5V to $V_{CC} + 0.5V$
DC Output Diode Current ( $I_{OK}$ )	
$V_O = -0.5V$	-20 mA
$V_O = V_{CC} + 0.5V$	+20 mA
DC Output Voltage ( $V_O$ )	-0.5V to $V_{CC} + 0.5V$
DC Output Source	
or Sink Current ( $I_O$ )	$\pm 50$ mA
DC $V_{CC}$ or Ground Current	
per Output Pin ( $I_{CC}$ or $I_{GND}$ )	$\pm 50$ mA
Storage Temperature ( $T_{STG}$ )	-65°C to +150°C
Junction Temperature ( $T_J$ )	
CDIP	175°C

'ACT	4.5V to 5.5V
Input Voltage ( $V_I$ )	0V to $V_{CC}$
Output Voltage ( $V_O$ )	0V to $V_{CC}$
Operating Temperature ( $T_A$ )	
54AC/ACT	-55°C to +125°C
Minimum Input Edge Rate ( $\Delta V/\Delta t$ )	
'AC Devices	
$V_{IN}$ from 30% to 70% of $V_{CC}$	
$V_{CC}$ @ 3.3V, 4.5V, 5.5V	125 mV/ns
Minimum Input Edge Rate ( $\Delta V/\Delta t$ )	
'ACT Devices	
$V_{IN}$ from 0.8V to 2.0V	
$V_{CC}$ @ 4.5V, 5.5V	125 mV/ns

**Note 1:** Absolute maximum ratings are those values beyond which damage to the device may occur. The databook specifications should be met, without exception, to ensure that the system design is reliable over its power supply, temperature, and output/input loading variables. National does not recommend operation of FACT® circuits outside databook specifications.

**Recommended Operating Conditions**

Supply Voltage ( $V_{CC}$ )	
'AC	2.0V to 6.0V

**DC Characteristics for 'AC Family Devices**

Symbol	Parameter	$V_{CC}$ (V)	54AC	Units	Conditions	
			$T_A =$ -55°C to +125°C			
			Guaranteed Limits			
$V_{IH}$	Minimum High Level Input Voltage	3.0	2.1	V	$V_{OUT} = 0.1V$ or $V_{CC} - 0.1V$	
		4.5	3.15			
		5.5	3.85			
$V_{IL}$	Maximum Low Level Input Voltage	3.0	0.9	V	$V_{OUT} = 0.1V$ or $V_{CC} - 0.1V$	
		4.5	1.35			
		5.5	1.65			
$V_{OH}$	Minimum High Level Output Voltage	3.0	2.9	V	$I_{OUT} = -50 \mu A$	
		4.5	4.4			
		5.5	5.4			
		3.0	2.4	V	(Note 2) $V_{IN} = V_{IL}$ or $V_{IH}$	
		4.5	3.7		$I_{OH}$	-12 mA
		5.5	4.7		$I_{OH}$	-24 mA

## DC Characteristics for 'AC Family Devices (Continued)

Symbol	Parameter	V <sub>CC</sub> (V)	54AC		Units	Conditions	
			T <sub>A</sub> = -55°C to +125°C				
			Guaranteed Limits				
V <sub>OL</sub>	Maximum Low Level Output Voltage	3.0	0.1		V	I <sub>OUT</sub> = 50 μA	
		4.5	0.1				
		5.5	0.1				
			3.0	0.50		V	(Note 2) V <sub>IN</sub> = V <sub>IL</sub> or V <sub>IH</sub> I <sub>OL</sub> 12 mA 24 mA 24 mA
			4.5	0.50			
			5.5	0.50			
I <sub>IN</sub>	Maximum Input Leakage Current	5.5	±1.0		μA	V <sub>I</sub> = V <sub>CC</sub> , GND	
I <sub>OZ</sub>	Maximum TRI-STATE Current	5.5	±5.0		μA	V <sub>I</sub> (OE) = V <sub>IL</sub> , V <sub>IH</sub> V <sub>I</sub> = V <sub>CC</sub> , V <sub>GND</sub> V <sub>O</sub> = V <sub>CC</sub> , GND	
I <sub>OLD</sub>	(Note 3) Minimum Dynamic Output Current	5.5	50		mA	V <sub>OLD</sub> = 1.65V Max	
I <sub>OHD</sub>	Maximum Output Current	5.5	-50		mA	V <sub>OHD</sub> = 3.85V Min	
I <sub>CC</sub>	Maximum Quiescent Supply Current	5.5	80.0		μA	V <sub>IN</sub> = V <sub>CC</sub> or GND	

**Note 2:** All outputs loaded; thresholds on input associated with output under test.

**Note 3:** Maximum test duration 2.0 ms, one output loaded at a time.

**Note 4:** I<sub>IN</sub> and I<sub>CC</sub> @ 3.0V are guaranteed to be less than or equal to the respective limit @ 5.5V V<sub>CC</sub>.

**Note 5:** I<sub>CC</sub> for 54AC @ 25°C is identical to 74AC @ 25°C.

## DC Characteristics for 'ACT Family Devices

Symbol	Parameter	V <sub>CC</sub> (V)	54ACT		Units	Conditions	
			T <sub>A</sub> = -55°C to +125°C				
			Guaranteed Limits				
V <sub>IH</sub>	Minimum High Level Input Voltage	4.5	2.0		V	V <sub>OUT</sub> = 0.1V or V <sub>CC</sub> - 0.1V	
		5.5	2.0				
V <sub>IL</sub>	Maximum Low Level Input Voltage	4.5	0.8		V	V <sub>OUT</sub> = 0.1V or V <sub>CC</sub> - 0.1V	
		5.5	0.8				
V <sub>OH</sub>	Minimum High Level Output Voltage	4.5	4.4		V	I <sub>OUT</sub> = -50 μA	
		5.5	5.4				
			4.5	3.70		V	(Note 6) V <sub>IN</sub> = V <sub>IL</sub> or V <sub>IH</sub> I <sub>OH</sub> -24 mA -24 mA
			5.5	4.70			
			4.5	0.1			
			5.5	0.1			
V <sub>OL</sub>	Maximum Low Level Output Voltage	4.5	0.1		V	I <sub>OUT</sub> = 50 μA	
		5.5	0.1				
		4.5	0.50		V	(Note 6) V <sub>IN</sub> = V <sub>IL</sub> or V <sub>IH</sub> I <sub>OL</sub> 24 mA 24 mA	
		5.5	0.50				
I <sub>IN</sub>	Maximum Input Leakage Current	5.5	±1.0		μA	V <sub>I</sub> = V <sub>CC</sub> , GND	
I <sub>OZ</sub>	Maximum TRI-STATE	5.5	±5.0		μA	V <sub>I</sub> = V <sub>IL</sub> , V <sub>IH</sub>	

## DC Characteristics for 'ACT Family Devices (Continued)

Symbol	Parameter	V <sub>CC</sub> (V)	54ACT	Units	Conditions
			T <sub>A</sub> = -55°C to +125°C		
			Guaranteed Limits		
	Current				V <sub>O</sub> = V <sub>CC</sub> , GND
I <sub>CCT</sub>	Maximum I <sub>CC</sub> /Input	5.5	1.6	mA	V <sub>I</sub> = V <sub>CC</sub> - 2.1V
I <sub>OLD</sub>	(Note 7) Minimum Dynamic Output Current	5.5	50	mA	V <sub>OLD</sub> = 1.65V Max
I <sub>OHD</sub>		5.5	-50	mA	V <sub>OHD</sub> = 3.85V Min
I <sub>CC</sub>	Maximum Quiescent Supply Current	5.5	80.0	μA	V <sub>IN</sub> = V <sub>CC</sub> or GND

**Note 6:** All outputs loaded; thresholds on input associated with output under test.

**Note 7:** Maximum test duration 2.0 ms, one output loaded at a time.

**Note 8:** I<sub>CC</sub> for 54ACT @ 25°C is identical to 74ACT @ 25°C.

## AC Electrical Characteristics

Symbol	Parameter	V <sub>CC</sub> (V) (Note 9)	54AC		Units	Fig. No.
			T <sub>A</sub> = -55°C to +125°C C <sub>L</sub> = 50 pF			
			Min	Max		
t <sub>PLH</sub>	Propagation Delay Data to Output	3.3	1.0	12.5	ns	
		5.0	1.0	9.5		
t <sub>PHL</sub>	Propagation Delay Data to Output	3.3	1.0	12.0	ns	
		5.0	1.0	9.0		
t <sub>PZH</sub>	Output Enable Time	3.3	1.0	11.5	ns	
		5.0	1.0	9.0		
t <sub>PZL</sub>	Output Enable Time	3.3	1.0	13.0	ns	
		5.0	1.0	10.5		
t <sub>PHZ</sub>	Output Disable Time	3.3	1.0	12.5	ns	
		5.0	1.0	10.5		
t <sub>PLZ</sub>	Output Disable Time	3.3	1.0	13.0	ns	
		5.0	1.0	11.0		

**Note 9:** Voltage Range 3.3 is 3.3V ±0.3V  
Voltage Range 5.0 is 5.0V ±0.5V

## AC Electrical Characteristics

Symbol	Parameter	V <sub>CC</sub> (V) (Note 10)	54ACT		Units	Fig. No.
			T <sub>A</sub> = -55°C to +125°C C <sub>L</sub> = 50 pF			
			Min	Max		
t <sub>PLH</sub>	Propagation Delay Data to Output	5.0	1.0	10.0	ns	
t <sub>PHL</sub>	Propagation Delay Data to Output	5.0	1.0	10.0	ns	
t <sub>PZH</sub>	Output Enable Time	5.0	1.0	9.5	ns	
t <sub>PZL</sub>	Output Enable Time	5.0	1.0	11.0	ns	
t <sub>PHZ</sub>	Output Disable Time	5.0	1.0	11.0	ns	
t <sub>PLZ</sub>	Output Disable Time	5.0	1.0	11.5	ns	

**Note 10:** Voltage Range 5.0 is 5.0V ±0.5V

## Capacitance

Symbol	Parameter	Typ	Units	Conditions
C <sub>IN</sub>	Input Capacitance	4.5	pF	V <sub>CC</sub> = OPEN
C <sub>PD</sub>	Power Dissipation Capacitance	45.0	pF	V <sub>CC</sub> = 5.0V

**Physical Dimensions** inches (millimeters) unless otherwise noted

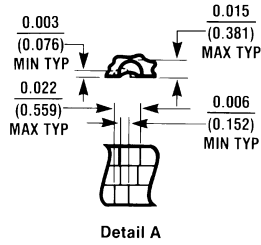
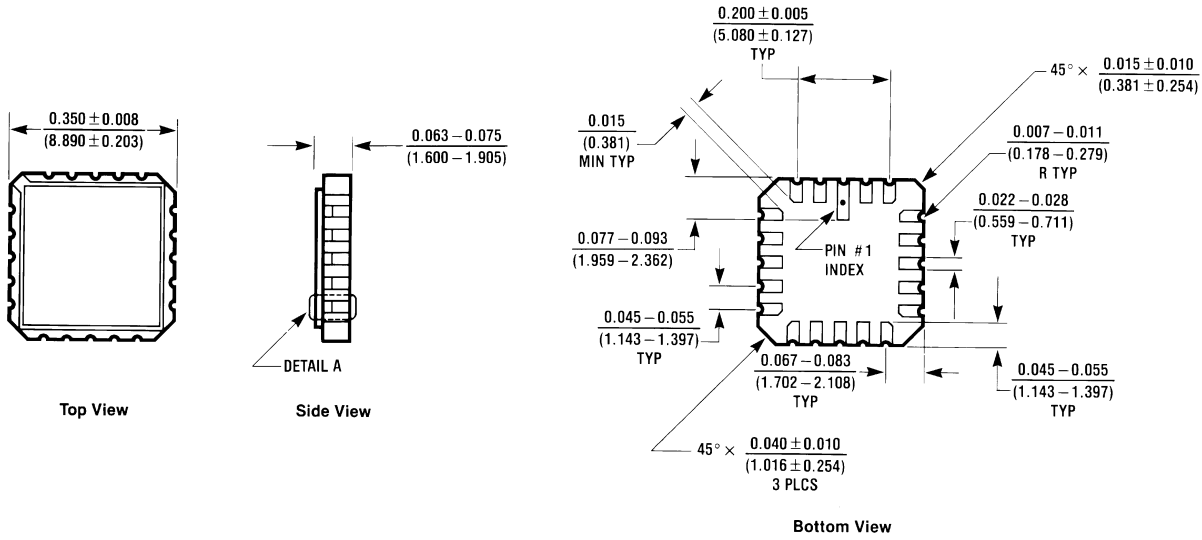

E20A (REV D)

**20-Terminal Ceramic Leadless Chip Carrier (L)  
 NS Package Number E20A**

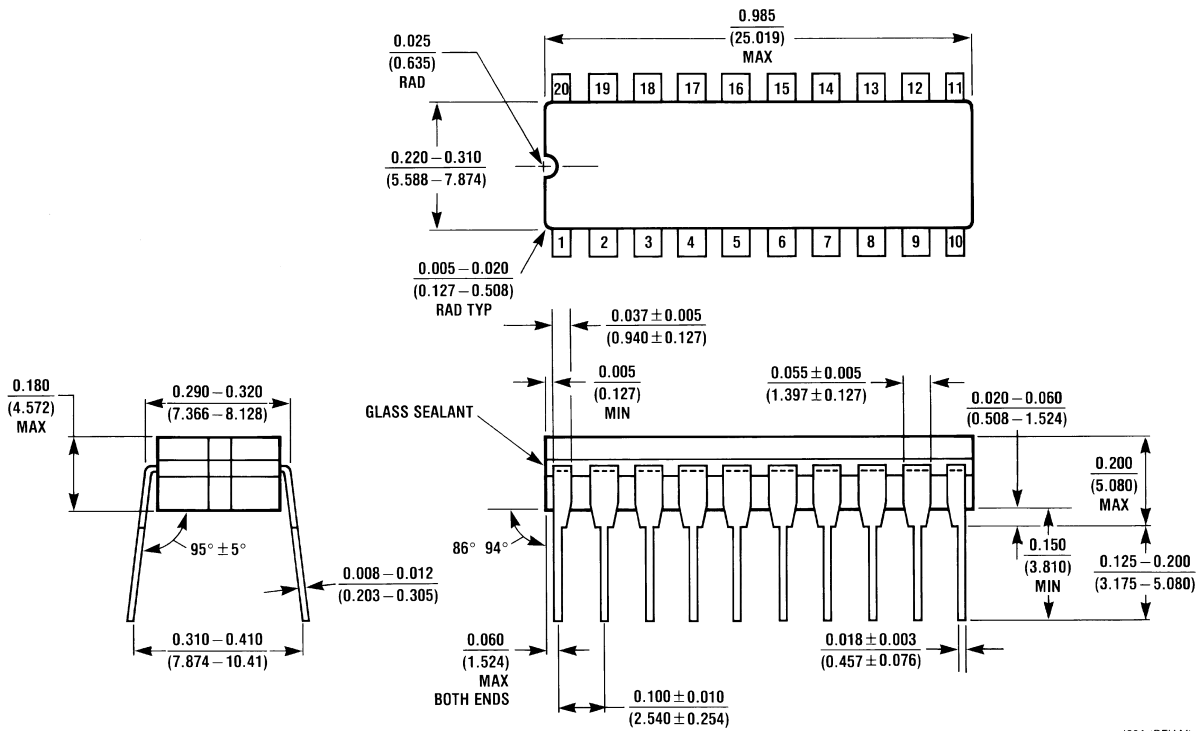

J20A (REV M)

**20-Lead Ceramic Dual-In-Line Package (D)  
 NS Package Number J20A**

**Physical Dimensions** inches (millimeters) unless otherwise noted (Continued)

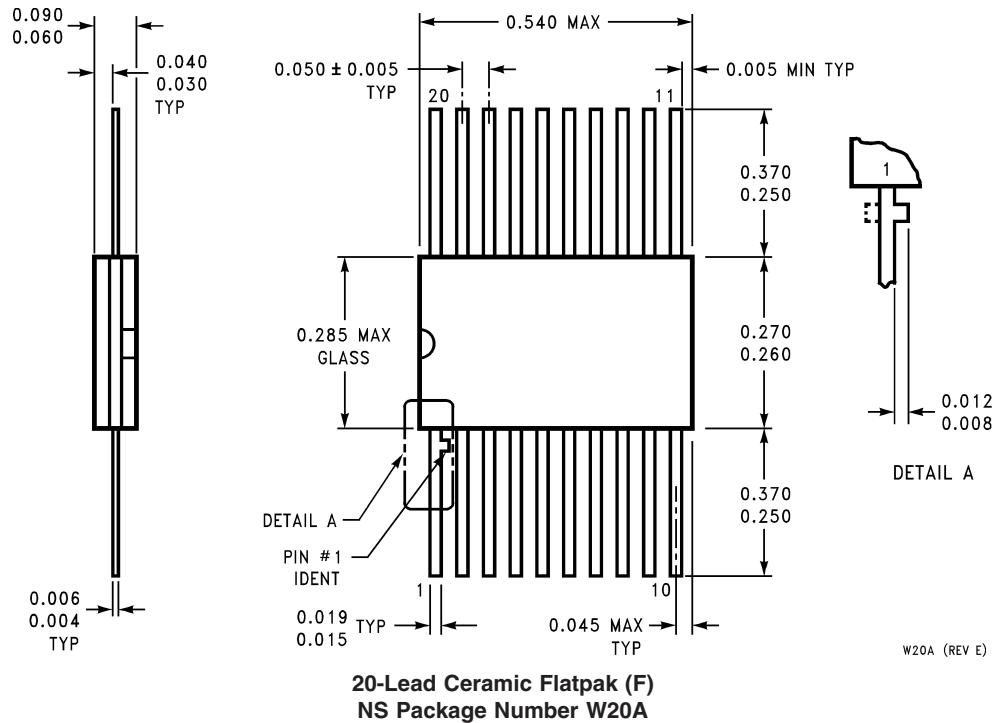

**LIFE SUPPORT POLICY**

NATIONAL'S PRODUCTS ARE NOT AUTHORIZED FOR USE AS CRITICAL COMPONENTS IN LIFE SUPPORT DEVICES OR SYSTEMS WITHOUT THE EXPRESS WRITTEN APPROVAL OF THE PRESIDENT AND GENERAL COUNSEL OF NATIONAL SEMICONDUCTOR CORPORATION. As used herein:

1. Life support devices or systems are devices or systems which, (a) are intended for surgical implant into the body, or (b) support or sustain life, and whose failure to perform when properly used in accordance with instructions for use provided in the labeling, can be reasonably expected to result in a significant injury to the user.
2. A critical component is any component of a life support device or system whose failure to perform can be reasonably expected to cause the failure of the life support device or system, or to affect its safety or effectiveness.



**National Semiconductor**  
Americas Customer  
Support Center  
Email: new.feedback@nsc.com  
Tel: 1-800-272-9959

**National Semiconductor**  
Europe Customer Support Center  
Fax: +49 (0) 180-530 85 86  
Email: europe.support@nsc.com  
Deutsch Tel: +49 (0) 69 9508 6208  
English Tel: +44 (0) 870 24 0 2171  
Français Tel: +33 (0) 1 41 91 8790

**National Semiconductor**  
Asia Pacific Customer  
Support Center  
Email: ap.support@nsc.com

**National Semiconductor**  
Japan Customer Support Center  
Fax: 81-3-5639-7507  
Email: jpn.feedback@nsc.com  
Tel: 81-3-5639-7560

www.national.com