

LMH6715

Dual Wideband Video Op Amp

General Description

The LMH6715 combines National's VIP10™ high speed complementary bipolar process with National's current feedback topology to produce a very high speed dual op amp. The LMH6715 provides 400MHz small signal bandwidth at a gain of +2V/V and 1300V/μs slew rate while consuming only 5.8mA per amplifier from ±5V supplies.

The LMH6715 offers exceptional video performance with its 0.02% and 0.02° differential gain and phase errors for NTSC and PAL video signals while driving up to four back terminated 75Ω loads. The LMH6715 also offers a flat gain response of 0.1dB to 100MHz and very low channel-to-channel crosstalk of -70dB at 10MHz. Additionally, each amplifier can deliver 70mA of output current. This level of performance makes the LMH6715 an ideal dual op amp for high density, broadcast quality video systems.

The LMH6715's two very well matched amplifiers support a number of applications such as differential line drivers and receivers. In addition, the LMH6715 is well suited for Sallen Key active filters in applications such as anti-aliasing filters for high speed A/D converters. Its small 8-pin SOIC package, low power requirement, low noise and distortion allow the LMH6715 to serve portable RF applications such as IQ channels.

Features

- $T_A = 25^\circ\text{C}$, $R_L = 100\Omega$, typical values unless specified.
- Very low diff. gain, phase: 0.02%, 0.02°
- Wide bandwidth: 480MHz ($A_V = +1V/V$); 400MHz ($A_V = +2V/V$)
- 0.1dB gain flatness to 100MHz
- Low power: 5.8mA/channel
- -70dB channel-to-channel crosstalk (10MHz)
- Fast slew rate: 1300V/μs
- Unity gain stable
- Improved replacement for CLC412

Applications

- HDTV, NTSC & PAL video systems
- Video switching and distribution
- IQ amplifiers
- Wideband active filters
- Cable drivers
- DC coupled single-to-differential conversions

Differential Gain & Phase with Multiple Video Loads

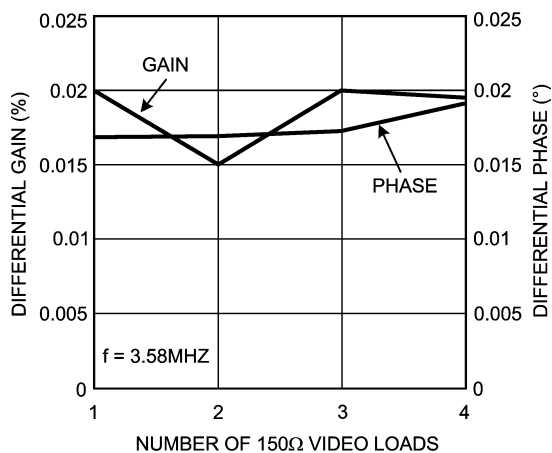

20042908

Frequency Response vs. V_{OUT}

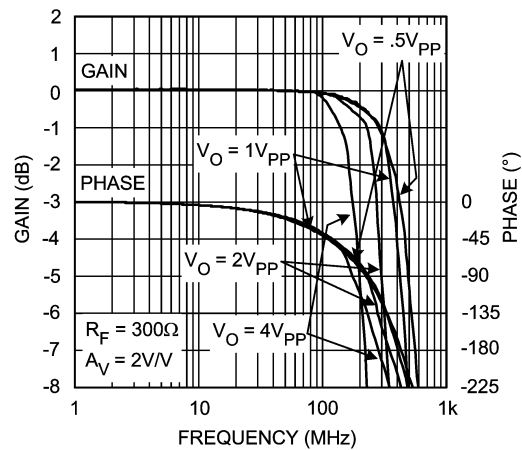

20042916

Absolute Maximum Ratings (Note 1)

If Military/Aerospace specified devices are required, please contact the National Semiconductor Sales Office/Distributors for availability and specifications.

ESD Tolerance (Note 4)	
Human Body Model	2000V
Machine Model	150V
V_{CC}	$\pm 6.75V$
I_{OUT}	(Note 3)
Common-Mode Input Voltage	$\pm V_{CC}$
Differential Input Voltage	2.2V
Maximum Junction Temperature	+150°C

Storage Temperature Range	-65°C to +150°C
Lead Temperature (Soldering 10 sec)	+300°C

Operating Ratings

Thermal Resistance		
Package	(θ_{JC})	(θ_{JA})
SOIC	65°C/W	145°C/W
Operating Temperature Range	-40°C to +85°C	
Nominal Operating Voltage	$\pm 5V$ to $\pm 6V$	

Electrical Characteristics

$A_V = +2$, $R_F = 500\Omega$, $V_{CC} = \pm 5V$, $R_L = 100\Omega$; unless otherwise specified. **Boldface** limits apply at the temperature extremes.

Symbol	Parameter	Conditions	Min	Typ	Max	Units
Frequency Domain Response						
SSBW	-3dB Bandwidth	$V_{OUT} < 0.5V_{PP}$, $R_F = 300\Omega$	280	400		MHz
LSBW	-3dB Bandwidth	$V_{OUT} < 4.0V_{PP}$, $R_F = 300\Omega$		170		MHz
	Gain Flatness	$V_{OUT} < 0.5V_{PP}$				
GFP	Peaking	DC to 100MHz, $R_F = 300\Omega$		0.1		dB
GFR	Rolloff	DC to 100MHz, $R_F = 300\Omega$		0.1		dB
LPD	Linear Phase Deviation	DC to 100MHz, $R_F = 300\Omega$		0.25		deg
DG	Differential Gain	$R_L = 150\Omega$, 4.43MHz		0.02		%
DP	Differential Phase	$R_L = 150\Omega$, 4.43MHz		0.02		deg
Time Domain Response						
Tr	Rise and Fall Time	0.5V Step		1.4		ns
		4V Step		3		ns
Ts	Settling Time to 0.05%	2V Step		12		ns
OS	Overshoot	0.5V Step		1		%
SR	Slew Rate	2V Step		1300		V/ μ s
Distortion And Noise Response						
HD2	2nd Harmonic Distortion	$2V_{PP}$, 20MHz		-60		dBc
HD3	3rd Harmonic Distortion	$2V_{PP}$, 20MHz		-75		dBc
	Equivalent Input Noise					
V_N	Non-Inverting Voltage	>1MHz		3.4		nV/ \sqrt{Hz}
I_N	Inverting Current	>1MHz		10.0		pA/ \sqrt{Hz}
I_{NN}	Non-Inverting Current	>1MHz		1.4		pA/ \sqrt{Hz}
SNF	Noise Floor	>1MHz		-153		dB _{1Hz}
XTLKA	Crosstalk	Input Referred 10MHz		-70		dB
Static, DC Performance						
V_{IO}	Input Offset Voltage			± 2	± 6 ± 8	mV
DV_{IO}	Average Drift			± 30		μ V/°C
I_{BN}	Input Bias Current	Non-Inverting		± 5	± 12 ± 20	μ A
DI_{BN}	Average Drift			± 30		nA/°C
I_{BI}	Input Bias Current	Inverting		± 6	± 21 ± 35	μ A
DI_{BI}	Average Drift			± 20		nA/°C
PSRR	Power Supply Rejection Ratio	DC	46 44	60		dB

Electrical Characteristics (Continued)

$A_V = +2$, $R_F = 500\Omega$, $V_{CC} = \pm 5\text{ V}$, $R_L = 100\Omega$; unless otherwise specified. **Boldface** limits apply at the temperature extremes.

Symbol	Parameter	Conditions	Min	Typ	Max	Units
CMRR	Common Mode Rejection Ratio	DC	50 47	56		dB
I_{CC}	Supply Current per Amplifier	$R_L = \infty$	4.7 4.1	5.8	7.6 8.1	mA

Miscellaneous Performance

R_{IN}	Input Resistance	Non-Inverting		1000		k Ω
C_{IN}	Input Capacitance	Non-Inverting		1.0		pF
R_{OUT}	Output Resistance	Closed Loop		.06		Ω
V_O	Output Voltage Range	$R_L = \infty$		± 4.0		V
V_{OL}		$R_L = 100\Omega$	± 3.5 ± 3.4	± 3.9		V
CMIR	Input Voltage Range	Common Mode		± 2.2		V
I_O	Output Current			70		mA

Note 1: Absolute Maximum Ratings indicate limits beyond which damage to the device may occur. Operating Ratings indicate conditions for which the device is intended to be functional, but specific performance is not guaranteed. For guaranteed specifications, see the Electrical Characteristics tables.

Note 2: Electrical Table values apply only for factory testing conditions at the temperature indicated. Factory testing conditions result in very limited self-heating of the device such that $T_J = T_A$. No guarantee of parametric performance is indicated in the electrical tables under conditions of internal self heating where $T_J > T_A$. See Applications Section for information on temperature de-rating of this device." Min/Max ratings are based on product characterization and simulation. Individual parameters are tested as noted.

Note 3: The maximum output current (I_{OUT}) is determined by device power dissipation limitations. See the Power Dissipation section of the Application Division for more details.

Note 4: Human body model, 1.5k Ω in series with 100pF. Machine model, 0 Ω in series with 200pF.

Connection Diagram

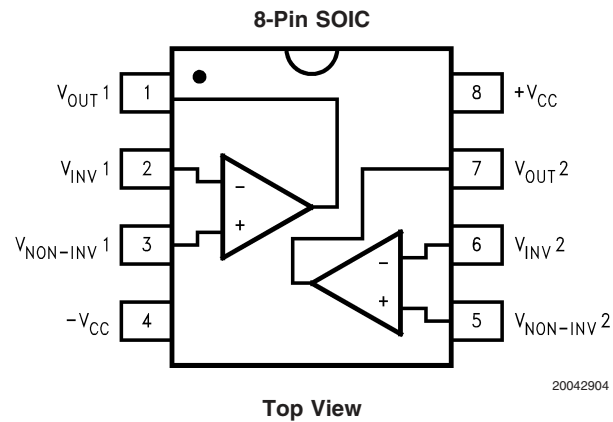

Ordering Information

Package	Part Number	Package Marking	Transport Media	NSC Drawing
8-pin SOIC	LMH6715MA	LMH6715MA	Rails	M08A
	LMH6715MAX		2.5k Units Tape and Reel	

Typical Performance Characteristics ($T_A = 25^\circ\text{C}$, $V_{CC} = \pm 5\text{V}$, $A_V = \pm 2\text{V/V}$, $R_F = 500\Omega$, $R_L = 100\Omega$, unless otherwise specified).

Non-Inverting Frequency Response

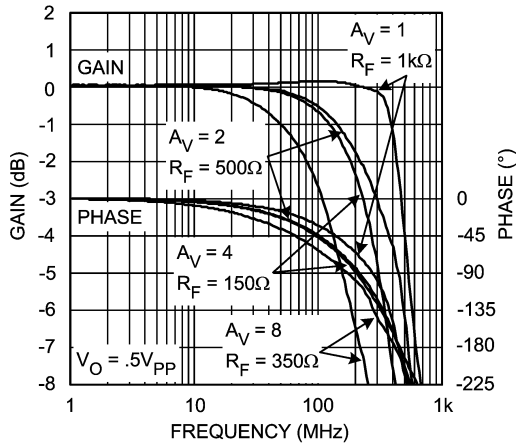

20042913

Inverting Frequency Response

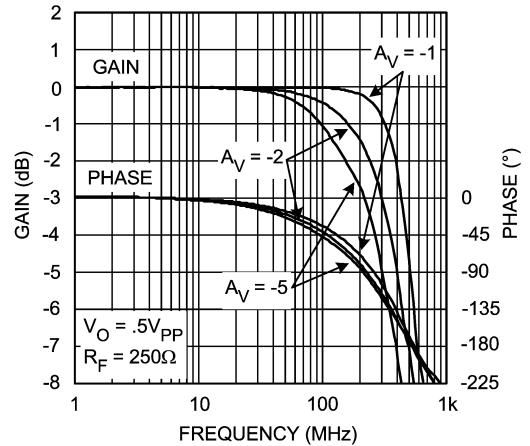

20042912

Non-Inverting Frequency Response vs. V_{OUT}

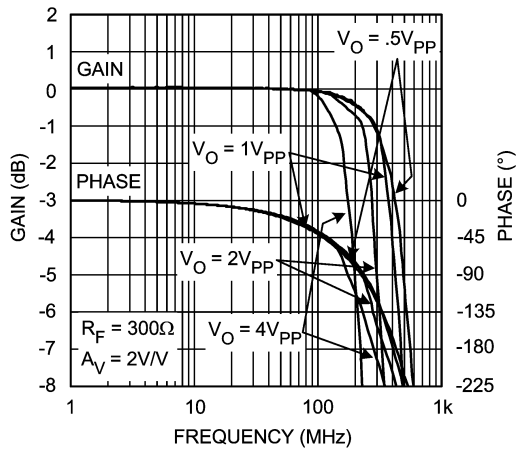

20042916

Small Signal Channel Matching

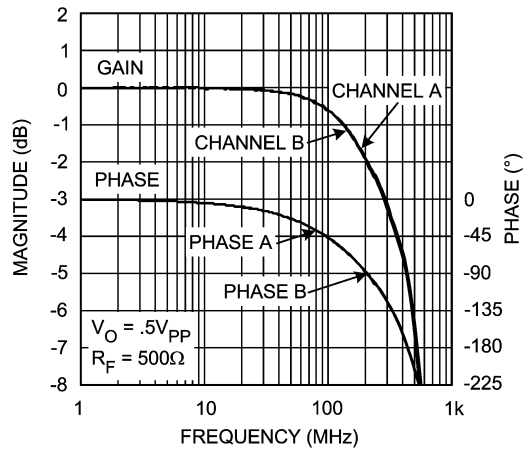

20042901

Frequency Response vs. Load Resistance

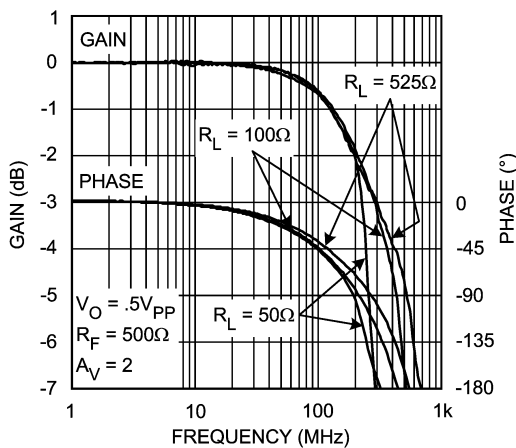

20042915

Non-Inverting Frequency Response vs. R_F

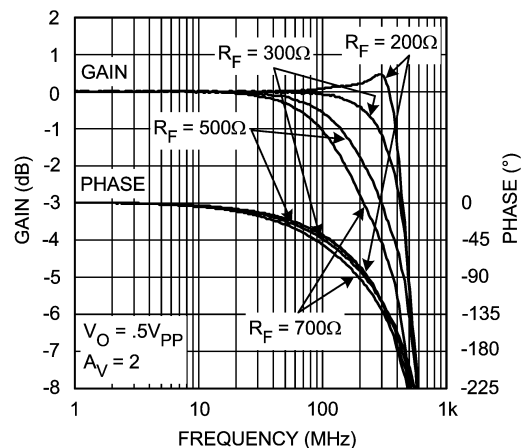

20042914

Typical Performance Characteristics ($T_A = 25^\circ\text{C}$, $V_{CC} = \pm 5\text{V}$, $A_V = \pm 2\text{V/V}$, $R_F = 500\Omega$, $R_L = 100\Omega$, unless otherwise specified). (Continued)

Small Signal Pulse Response

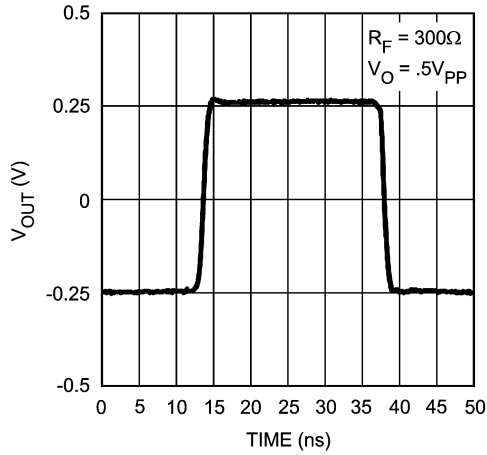

20042918

Large Signal Pulse Response

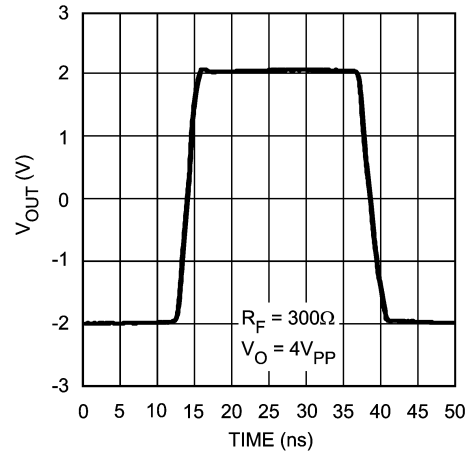

20042919

Input-Referred Crosstalk

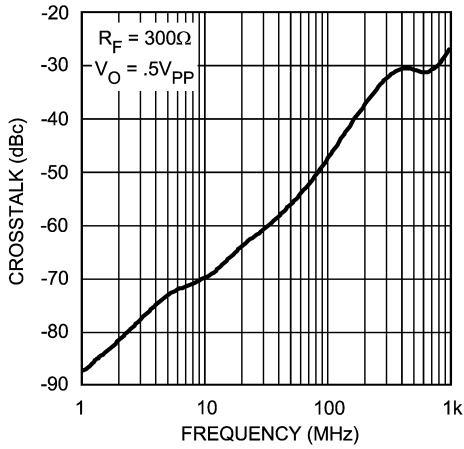

20042907

Settling Time vs. Accuracy

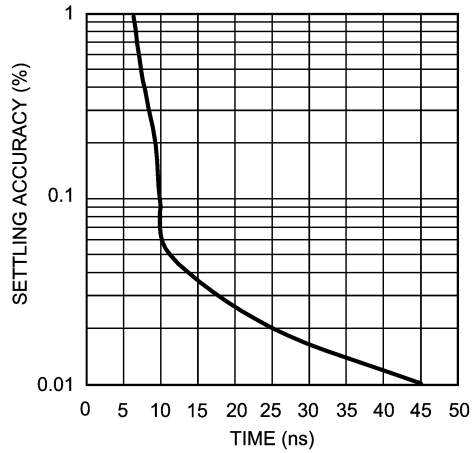

20042924

-3dB Bandwidth vs. V_{OUT}

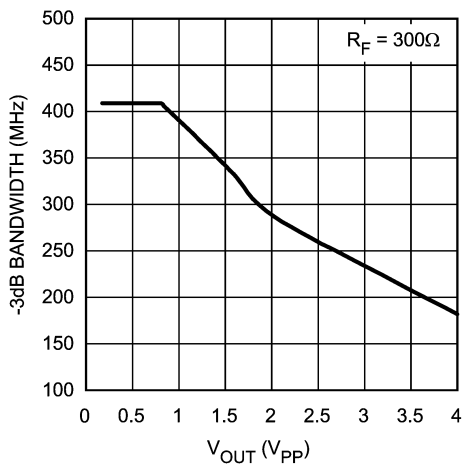

20042925

DC Errors vs. Temperature

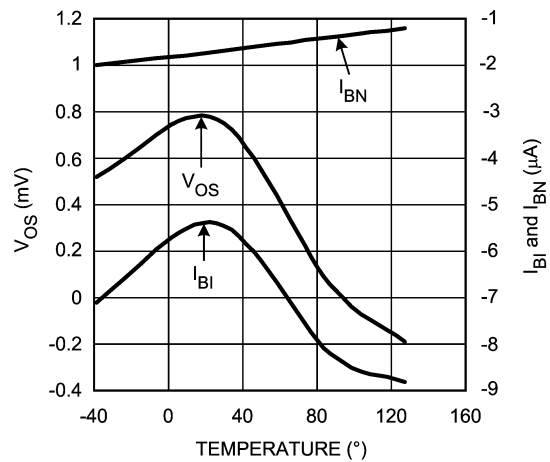

20042926

Typical Performance Characteristics ($T_A = 25^\circ\text{C}$, $V_{CC} = \pm 5\text{V}$, $A_V = \pm 2\text{V/V}$, $R_F = 500\Omega$, $R_L = 100\Omega$, unless otherwise specified). (Continued)

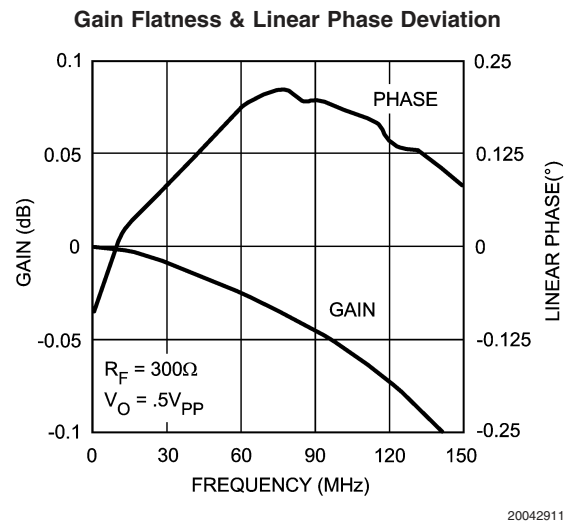
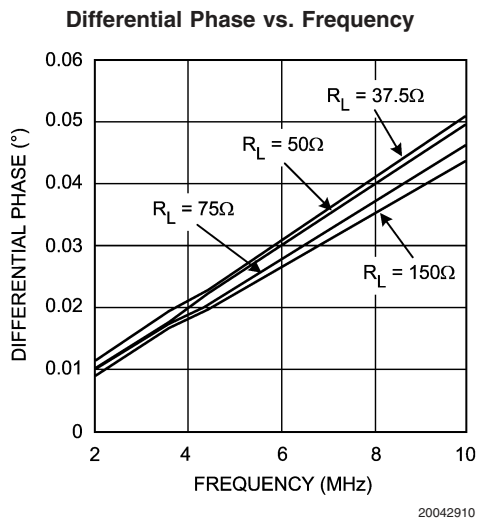
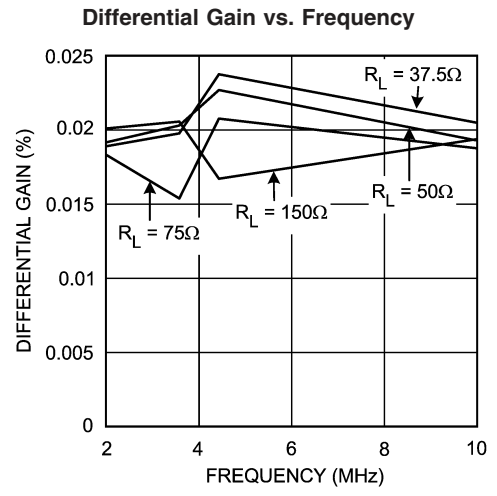
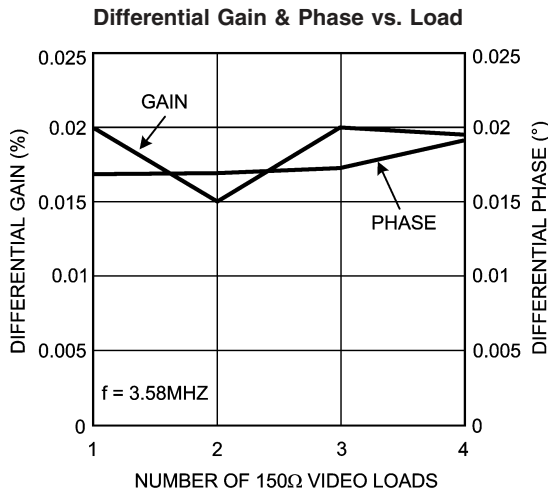
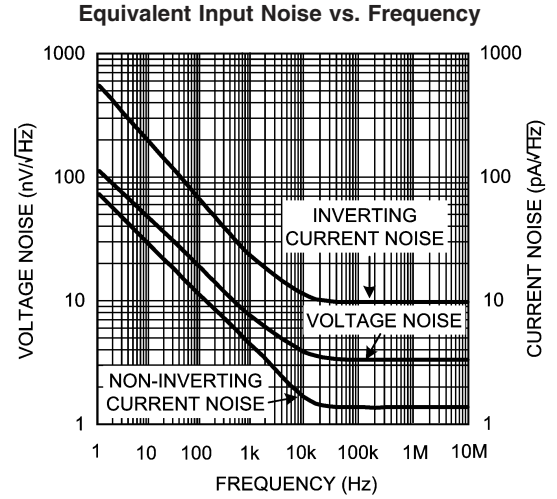
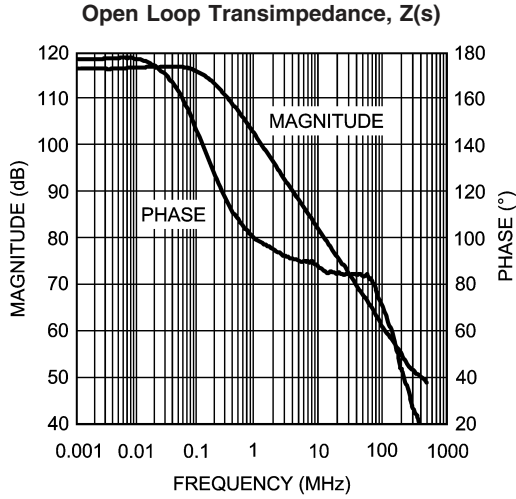

Typical Performance Characteristics ($T_A = 25^\circ\text{C}$, $V_{CC} = \pm 5\text{V}$, $A_V = \pm 2\text{V/V}$, $R_F = 500\Omega$, $R_L = 100\Omega$, unless otherwise specified). (Continued)

2nd Harmonic Distortion vs. Output Voltage

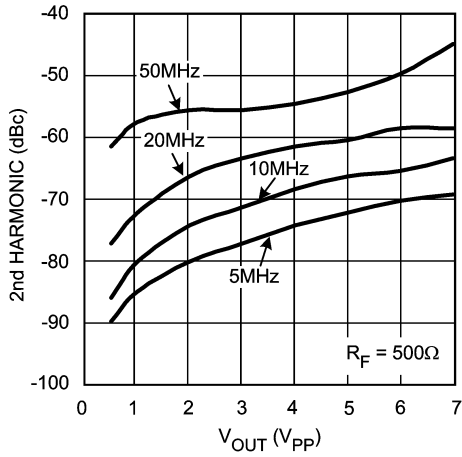

20042902

3rd Harmonic Distortion vs. Output Voltage

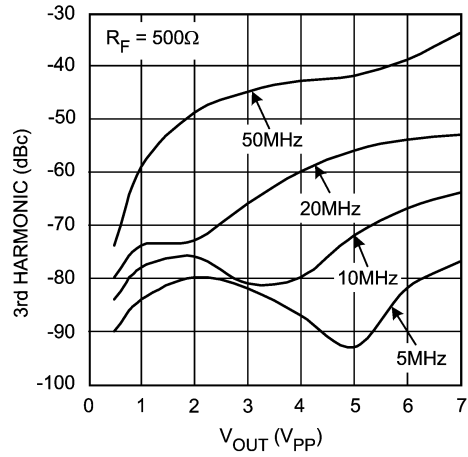

20042905

Closed Loop Output Resistance

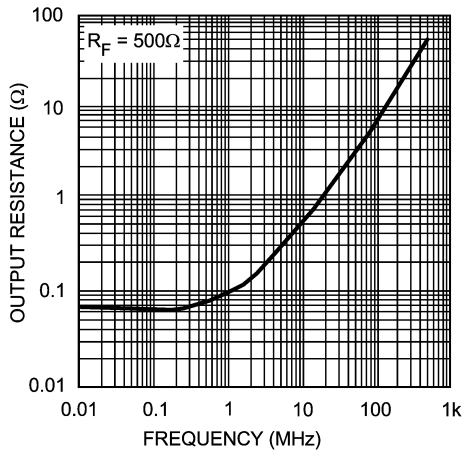

20042906

PSRR & CMRR

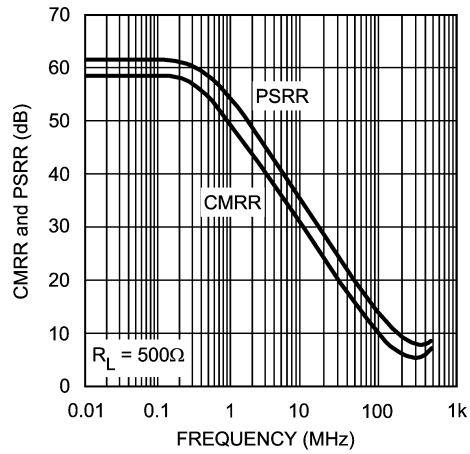

20042917

Suggested R_S vs. C_L

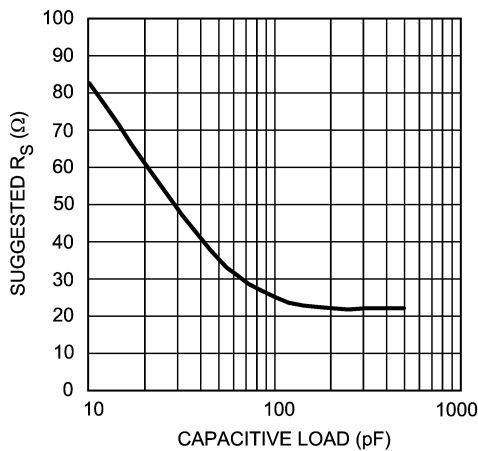

20042927

Application Section

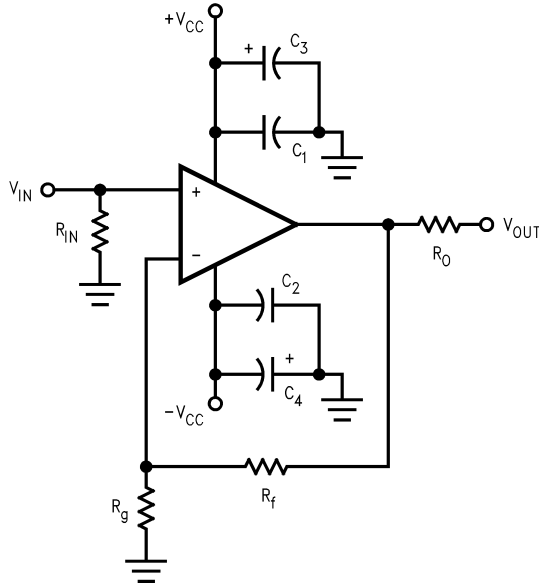

20042935

FIGURE 1. Non-Inverting Configuration with Power Supply Bypassing

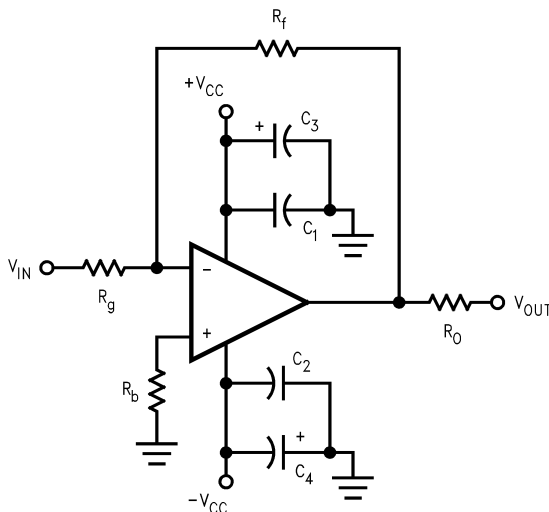

20042937

FIGURE 2. Inverting Configuration with Power Supply Bypassing

Application Introduction

Offered in an 8-pin package for reduced space and cost, the wideband LMH6715 dual current-feedback op amp provides closely matched DC and AC electrical performance characteristics making the part an ideal choice for wideband signal processing. Applications such as broadcast quality video systems, IQ amplifiers, filter blocks, high speed peak detectors, integrators and transimpedance amplifiers will all find superior performance in the LMH6715 dual op amp.

FEEDBACK RESISTOR SELECTION

One of the key benefits of a current feedback operational amplifier is the ability to maintain optimum frequency response independent of gain by using appropriate values for the feedback resistor (R_F). The Electrical Characteristics and Typical Performance plots specify an R_F of 500Ω , a gain of $+2V/V$ and $\pm 5V$ power supplies (unless otherwise specified). Generally, lowering R_F from its recommended value will peak the frequency response and extend the bandwidth while increasing the value of R_F will cause the frequency response to roll off faster. Reducing the value of R_F too far below its recommended value will cause overshoot, ringing and, eventually, oscillation.

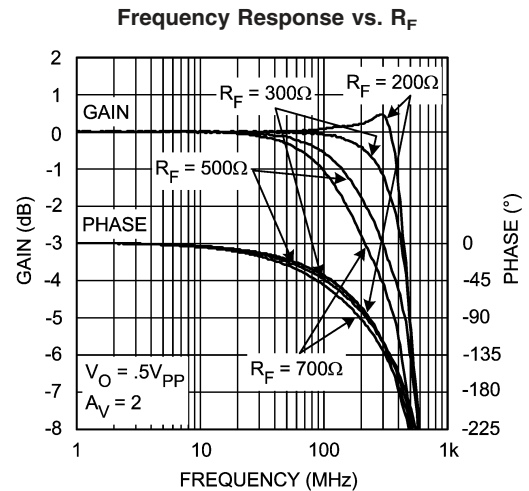

20042914

The plot labeled “Frequency Response vs. R_F ” shows the LMH6715’s frequency response as R_F is varied ($R_L = 100\Omega$, $A_V = +2$). This plot shows that an R_F of 200Ω results in peaking and marginal stability. An R_F of 300Ω gives near maximal bandwidth and gain flatness with good stability, but with very light loads ($R_L > 300\Omega$) the device may show some peaking. An R_F of 500Ω gives excellent stability with good bandwidth and is the recommended value for most applications. Since all applications are slightly different it is worth some experimentation to find the optimal R_F for a given circuit. For more information see Application Note OA-13 which describes the relationship between R_F and closed-loop frequency response for current feedback operational amplifiers.

When configuring the LMH6715 for gains other than $+2V/V$, it is usually necessary to adjust the value of the feedback resistor. The two plots labeled “ R_F vs. Non-inverting Gain” and “ R_F vs. Inverting Gain” provide recommended feedback resistor values for a number of gain selections.

Application Introduction (Continued)

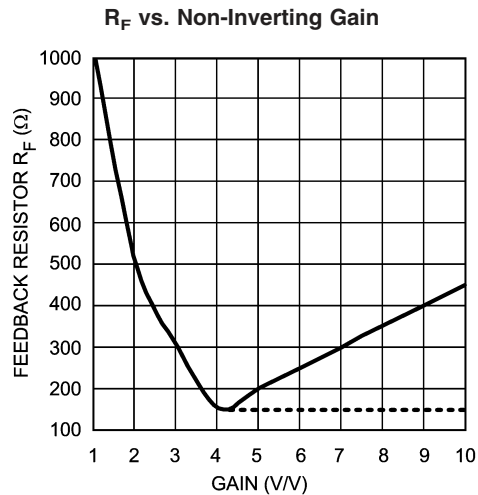

20042921

Both plots show the value of R_F approaching a minimum value (dashed line) at high gains. Reducing the feedback resistor below this value will result in instability and possibly oscillation. The recommended value of R_F is depicted by the solid line, which begins to increase at higher gains. The reason that a higher R_F is required at higher gains is the need to keep R_G from decreasing too far below the output impedance of the input buffer. For the LMH6715 the output resistance of the input buffer is approximately 160Ω and 50Ω is a practical lower limit for R_G . Due to the limitations on R_G the LMH6715 begins to operate in a gain bandwidth limited fashion for gains of $\pm 5V/V$ or greater.

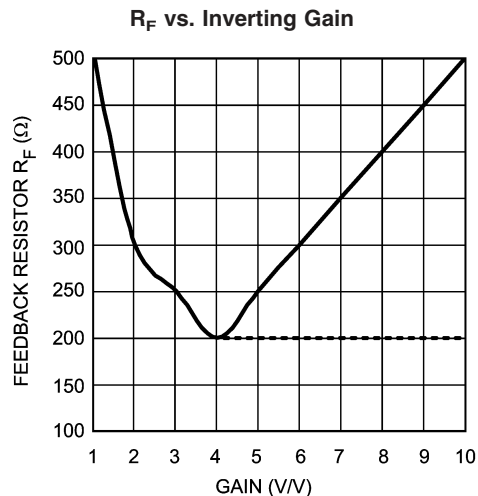

20042922

When using the LMH6715 as a replacement for the CLC412, identical bandwidth can be obtained by using an appropriate value of R_F . The chart "Frequency Response vs. R_F " shows that an R_F of approximately 700Ω will provide bandwidth very close to that of the CLC412. At other gains a similar increase in R_F can be used to match the new and old parts.

CIRCUIT LAYOUT

With all high frequency devices, board layouts with stray capacitances have a strong influence over AC performance. The LMH6715 is no exception and its input and output pins are particularly sensitive to the coupling of parasitic capaci-

tances (to AC ground) arising from traces or pads placed too closely (<0.1") to power or ground planes. In some cases, due to the frequency response peaking caused by these parasitics, a small adjustment of the feedback resistor value will serve to compensate the frequency response. Also, it is very important to keep the parasitic capacitance across the feedback resistor to an absolute minimum.

The performance plots in the data sheet can be reproduced using the evaluation boards available from National. The CLC730036 board uses all SMT parts for the evaluation of the LMH6715. The board can serve as an example layout for the final production printed circuit board.

Care must also be taken with the LMH6715's layout in order to achieve the best circuit performance, particularly channel-to-channel isolation. The decoupling capacitors (both tantalum and ceramic) must be chosen with good high frequency characteristics to decouple the power supplies and the physical placement of the LMH6715's external components is critical. Grouping each amplifier's external components with their own ground connection and separating them from the external components of the opposing channel with the maximum possible distance is recommended. The input (R_{IN}) and gain setting resistors (R_F) are the most critical. It is also recommended that the ceramic decoupling capacitor (0.1μF chip or radial-leaded with low ESR) should be placed as closely to the power pins as possible.

POWER DISSIPATION

Follow these steps to determine the Maximum power dissipation for the LMH6715:

1. Calculate the quiescent (no-load) power: $P_{AMP} = I_{CC} (V_{CC} - V_{EE})$
2. Calculate the RMS power at the output stage: $P_O = (V_{CC} - V_{LOAD})(I_{LOAD})$, where V_{LOAD} and I_{LOAD} are the voltage and current across the external load.
3. Calculate the total RMS power: $P_t = P_{AMP} + P_O$

The maximum power that the LMH6715, package can dissipate at a given temperature can be derived with the following equation:

$P_{max} = (150^\circ - T_{amb}) / \theta_{JA}$, where T_{amb} = Ambient temperature ($^\circ C$) and θ_{JA} = Thermal resistance, from junction to ambient, for a given package ($^\circ C/W$). For the SOIC package θ_{JA} is 145 $^\circ C/W$.

MATCHING PERFORMANCE

With proper board layout, the AC performance match between the two LMH6715's amplifiers can be tightly controlled as shown in Typical Performance plot labeled "Small-Signal Channel Matching".

The measurements were performed with SMT components using a feedback resistor of 300Ω at a gain of +2V/V.

The LMH6715's amplifiers, built on the same die, provide the advantage of having tightly matched DC characteristics.

SLEW RATE AND SETTLING TIME

One of the advantages of current-feedback topology is an inherently high slew rate which produces a wider full power bandwidth. The LMH6715 has a typical slew rate of 1300V/μs. The required slew rate for a design can be calculated by the following equation: $SR = 2\pi f V_{pk}$.

Careful attention to parasitic capacitances is critical to achieving the best settling time performance. The LMH6715

Application Introduction (Continued)

has a typical short term settling time to 0.05% of 12ns for a 2V step. Also, the amplifier is virtually free of any long term thermal tail effects at low gains.

When measuring settling time, a solid ground plane should be used in order to reduce ground inductance which can cause common-ground-impedance coupling. Power supply and ground trace parasitic capacitances and the load capacitance will also affect settling time.

Placing a series resistor (R_s) at the output pin is recommended for optimal settling time performance when driving a capacitive load. The Typical Performance plot labeled “ R_s and Settling Time vs. Capacitive Load” provides a means for selecting a value of R_s for a given capacitive load.

DC & NOISE PERFORMANCE

A current-feedback amplifier’s input stage does not have equal nor correlated bias currents, therefore they cannot be canceled and each contributes to the total DC offset voltage at the output by the following equation:

$$V_{\text{OFFSET}} = \pm \left[I_{\text{BN}} \times R_s \left[1 + \frac{R_f}{R_g} \right] + V_{\text{IO}} \left[1 + \frac{R_f}{R_g} \right] + I_{\text{BI}} \times R_f \right]$$

The input resistance is the resistance looking from the non-inverting input back toward the source. For inverting DC-offset calculations, the source resistance seen by the input resistor R_g must be included in the output offset calculation as a part of the non-inverting gain equation. Application note OA-7 gives several circuits for DC offset correction. The noise currents for the inverting and non-inverting inputs are graphed in the Typical Performance plot labeled “Equivalent Input Noise”. A more complete discussion of amplifier input-referred noise and external resistor noise contribution can be found in OA-12.

DIFFERENTIAL GAIN & PHASE

The LMH6715 can drive multiple video loads with very low differential gain and phase errors. The Typical Performance plots labeled “Differential Gain vs. Frequency” and “Differential Phase vs. Frequency” show performance for loads from 1 to 4. The Electrical Characteristics table also specifies performance for one 150Ω load at 4.43MHz. For NTSC video, the performance specifications also apply. Application note OA-24 “Measuring and Improving Differential Gain & Differential Phase for Video”, describes in detail the techniques used to measure differential gain and phase.

I/O VOLTAGE & OUTPUT CURRENT

The usable common-mode input voltage range (CMIR) of the LMH6715 specified in the Electrical Characteristics table of the data sheet shows a range of ±2.2 volts. Exceeding this range will cause the input stage to saturate and clip the output signal.

The output voltage range is determined by the load resistor and the choice of power supplies. With ±5 volts the class A/B output driver will typically drive ±3.9V into a load resistance of 100Ω. Increasing the supply voltages will change the common-mode input and output voltage swings while at the same time increase the internal junction temperature.

Applications Circuits

SINGLE-TO-DIFFERENTIAL LINE DRIVER

The LMH6715’s well matched AC channel-response allows a single-ended input to be transformed to highly matched push-pull driver. From a 1V single-ended input the circuit of *Figure 3* produces 1V differential signal between the two outputs. For larger signals the input voltage divider ($R_1 = 2R_2$) is necessary to limit the input voltage on channel 2.

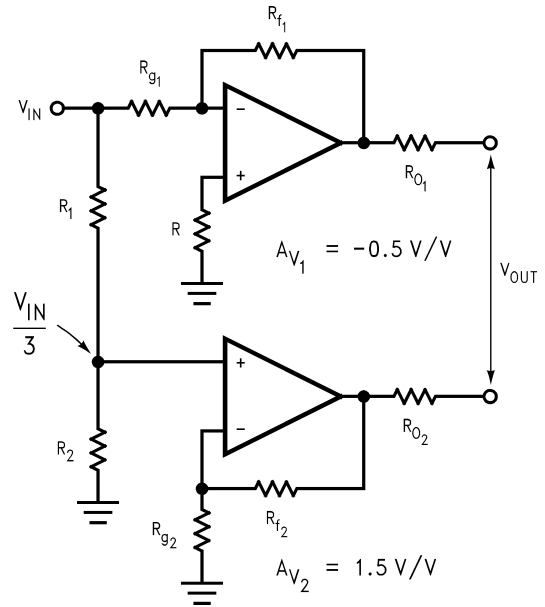

20042945

FIGURE 3. Single-to-Differential Line Driver

DIFFERENTIAL LINE RECEIVER

Figure 4 and *Figure 5* show two different implementations of an instrumentation amplifier which convert differential signals to single-ended. *Figure 5* allows CMRR adjustment through R_2 .

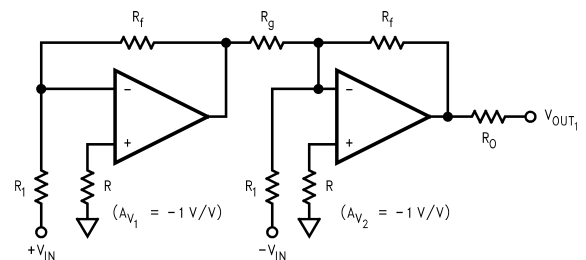

20042946

FIGURE 4. Differential Line Receiver

Applications Circuits (Continued)

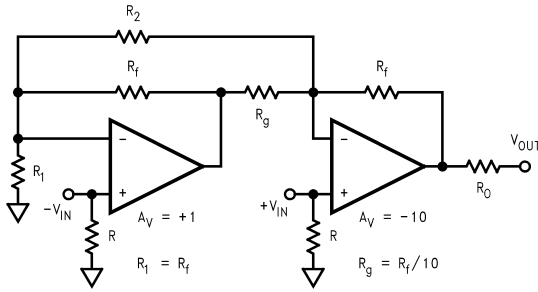

20042947

FIGURE 5. Differential Line Receiver with CMRR Adjustment

NON-INVERTING CURRENT-FEEDBACK INTEGRATOR

The circuit of *Figure 6* achieves its high speed integration by placing one of the LMH6715's amplifiers in the feedback loop of the second amplifier configured as shown.

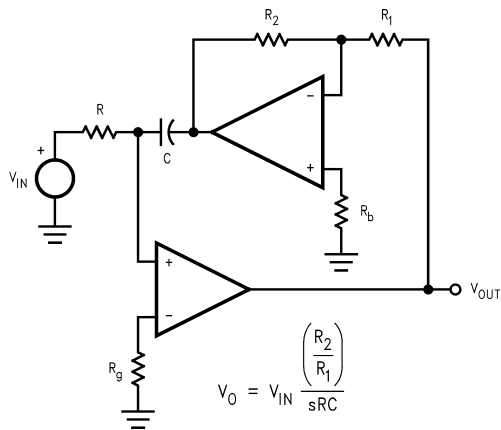

20042949

FIGURE 6. Current Feedback Integrator

LOW NOISE WIDE-BANDWIDTH TRANSIMPEDANCE AMPLIFIER

Figure 7 implements a low noise transimpedance amplifier using both channels of the LMH6715. This circuit takes advantage of the lower input bias current noise of the non-inverting input and achieves negative feedback through the second LMH6715 channel. The output voltage is set by the value of R_F while frequency compensation is achieved through the adjustment of R_T .

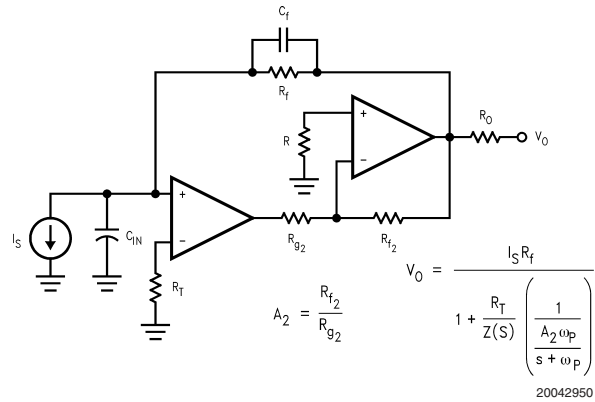

20042950

FIGURE 7. Low-Noise, Wide Bandwidth, Transimpedance Amp.

Physical Dimensions inches (millimeters)

unless otherwise noted

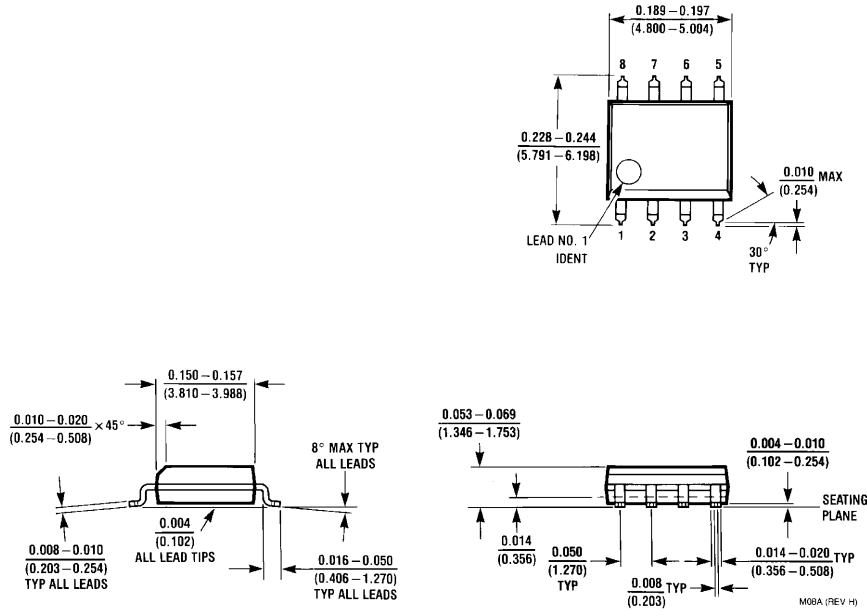

8-Pin SOIC
NS Package Number M08A

LIFE SUPPORT POLICY

NATIONAL'S PRODUCTS ARE NOT AUTHORIZED FOR USE AS CRITICAL COMPONENTS IN LIFE SUPPORT DEVICES OR SYSTEMS WITHOUT THE EXPRESS WRITTEN APPROVAL OF THE PRESIDENT AND GENERAL COUNSEL OF NATIONAL SEMICONDUCTOR CORPORATION. As used herein:

1. Life support devices or systems are devices or systems which, (a) are intended for surgical implant into the body, or (b) support or sustain life, and whose failure to perform when properly used in accordance with instructions for use provided in the labeling, can be reasonably expected to result in a significant injury to the user.
2. A critical component is any component of a life support device or system whose failure to perform can be reasonably expected to cause the failure of the life support device or system, or to affect its safety or effectiveness.



National Semiconductor
Americas Customer
Support Center
Email: new.feedback@nsc.com
Tel: 1-800-272-9959

www.national.com

National Semiconductor
Europe Customer Support Center
Fax: +49 (0) 180-530 85 86
Email: europe.support@nsc.com
Deutsch Tel: +49 (0) 69 9508 6208
English Tel: +44 (0) 870 24 0 2171
Français Tel: +33 (0) 1 41 91 8790

National Semiconductor
Asia Pacific Customer
Support Center
Fax: 65-6250 4466
Email: ap.support@nsc.com
Tel: 65-6254 4466

National Semiconductor
Japan Customer Support Center
Fax: 81-3-5639-7507
Email: nsj.crc@jksmtp.nsc.com
Tel: 81-3-5639-7560