

Ordering Information (Continued)

NS Part Number	JAN Part Number	NS Package Number	Package Description
LM139AWGRQMLV	5962R9673801VXA 100k rd(Si)	WG14A	14LD Ceramic SOIC
LM139AWLQMLV	5962L9673801VDA 50k rd(Si)	W14B	14LD CERPACK
LM139AWRQMLV	5962R9673801VDA 100k rd(Si)	W14B	14LD CERPACK

Connection Diagrams

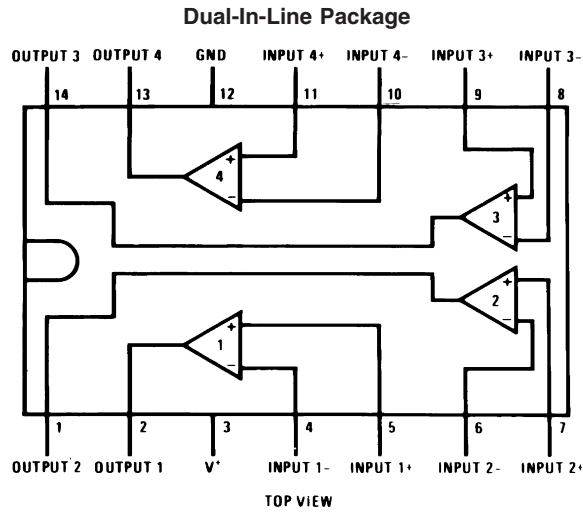

20122102

See NS Package Number J14A

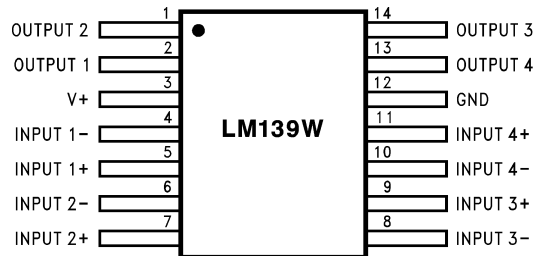

20122127

See NS Package Number W14B, WG14A

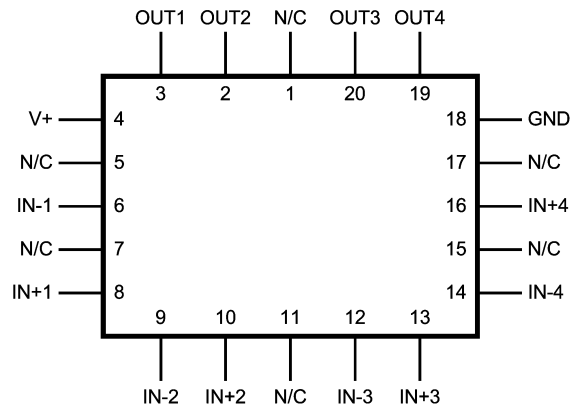

20122144

See NS Package Number E20A

Absolute Maximum Ratings (Note 1)

	LM139 / LM139A
Supply Voltage, V ⁺	36 V _{DC} or ±18 V _{DC}
Differential Input Voltage (Note 8)	36 V _{DC}
Input Voltage	-0.3 V _{DC} to +36 V _{DC}
Input Current (V _{IN} < -0.3 V _{DC}) (Note 3)	50 mA
Power Dissipation (Notes 4, 15)	
LCC	1250 mW
CERDIP	1200 mW
CERPACK	680 mW
SOIC	680 mW
Sink Current (approx) (Note 13)	20mA
Output Short-Circuit to GND, (Note 2)	Continuous
Storage Temperature Range	-65°C ≤ T _A ≤ +150°C
Maximum Junction Temperature (T _J)	+150°C
Lead Temperature (Soldering, 10 seconds)	300°C
Operating Temperature Range	-55°C ≤ T _A ≤ +125°C
Thermal Resistance	
θ _{JA}	
LCC (Still Air)	100°C/W
LCC (500LF / Min Air flow)	73°C/W
CERDIP (Still Air)	103°C/W
CERDIP (500LF / Min Air flow)	65°C/W
CERPACK (Still Air)	183°C/W
CERPACK (500LF / Min Air flow)	120°C/W
SOIC (Still Air)	183°C/W
SOIC (500LF / Min Air flow)	120°C/W
θ _{JC}	
LCC	28°C/W
CERDIP	23°C/W
CERPACK	23°C/W
SOIC	23°C/W
Package Weight (typical)	
LCC	470mg
CERDIP	2,190mg
CERPACK	460mg
SOIC	410mg
ESD rating (Note 14)	600V

Recommended Operating Conditions

Supply Voltage	5.0 V _{DC} to +30 V _{DC}
Ambient Operating Temperature Range	-55°C ≤ T _A ≤ +125°C

Quality Conformance Inspection

Mil-Std-883, Method 5005 — Group A

Subgroup	Description	Temp (°C)
1	Static tests at	25
2	Static tests at	125
3	Static tests at	-55
4	Dynamic tests at	25
5	Dynamic tests at	125
6	Dynamic tests at	-55
7	Functional tests at	25
8A	Functional tests at	125
8B	Functional tests at	-55
9	Switching tests at	25
10	Switching tests at	125
11	Switching tests at	-55

LM139 883 Electrical Characteristics

DC Parameters

The following conditions apply, unless otherwise specified. +V = 5V, $V_{CM} = 0V$

Symbol	Parameters	Conditions	Notes	Min	Max	Unit	Sub-groups
I_{CC}	Supply Current	$R_L = \text{Infinity}$			2.0	mA	1, 2, 3
	Supply Current	+V = 30V, $R_L = \text{Infinity}$			2.0	mA	1, 2, 3
V_{IO}	Input Offset Voltage	+V = 30V		-5.0	5.0	mV	1
				-9.0	9.0	mV	2, 3
		+V = 30V, $V_{CM} = 28.5V$		-5.0	5.0	mV	1
				-9.0	9.0	mV	2, 3
				-5.0	5.0	mV	1
				-9.0	9.0	mV	2, 3
CMRR	Common Mode Rejection Ratio	+V = 30V, $V_{CM} = 0V$ to 28.5V		60		dB	1
PSRR	Power Supply Rejection Ratio	+V = 5V to 30V		60		dB	1
$\pm I_{Bias}$	Input Bias Current	$V_O = 1.5V$	(Note 5)	-100	-1.0	nA	1
			(Note 5)	-300	-1.0	nA	2, 3
I_{IO}	Input Offset Current	$V_O = 1.5V$		-25	25	nA	1
				-100	100	nA	2, 3
I_{CEX}	Output Leakage Current	+V = 30V, $V_O = 30V$			1.0	μA	1, 2, 3
I_{Sink}	Output Sink Current	$V_O = 1.5V$		6.0		mA	1
V_{Sat}	Saturation Voltage	$I_{Sink} = 4mA$			400	mV	1
					700	mV	2, 3
A_V	Voltage Gain	+V = 15V, $R_L \geq 15\Omega K$, $V_I = 1V$ to 11V		50		V/mV	1
V_{CM}	Common Mode Voltage Range	+V = 30V	(Note 9)	0	V^- - (1.5)	V	1
			(Note 9)	0	V^+ - (2.0)	V	2, 3
V_{Diff}	Differential Input Voltage	+V = 30V, -V = 0V, + $V_I = 36V$, - $V_I = 0V$	(Note 10)		500	nA	1, 2, 3
		+V = 30V, -V = 0V, + $V_I = 0V$, - $V_I = 36V$	(Note 10)		500	nA	1, 2, 3

AC Parameters

The following conditions apply, unless otherwise specified. +V = 5V

Symbol	Parameters	Conditions	Notes	Min	Max	Unit	Sub-groups
t_{RLH}	Response Time	$V_{OD} = 5mV$			5.0	μS	9
		$V_{OD} = 50mV$			0.8	μS	9
t_{RHL}	Response Time	$V_{OD} = 5mV$			2.5	μS	9
		$V_{OD} = 50mV$			0.8	μS	9

LM139A SMD 5962–8773901 Electrical Characteristics

DC Parameters

The following conditions apply, unless otherwise specified. +V = 5V, $V_{CM} = 0V$

Symbol	Parameter	Conditions	Notes	Min	Max	Unit	Sub-groups
I_{CC}	Supply Current	+V = 30V, $R_L = \text{Infinity}$			3.0	mA	1, 2, 3
		$R_L = \text{Infinity}$			3.0	mA	1, 2, 3
I_{CEX}	Output Leakage Current	+V = 30V, $-V_I = 0V$, $+V_I \geq 1V$, $V_O = 30V$			0.5	μA	1
					1.0	μA	2, 3
V_{Sat}	Saturation Voltage	$I_{Sink} \leq 4mA$, $-V_I = 1V$, $+V_I = 0V$			400	mV	1
					700	mV	2, 3
I_{Sink}	Output Sink Current	$V_O \geq 1.5V$, $-V_I = 1V$, $+V_I = 0V$		6.0		mA	1
V_{IO}	Input Offset Voltage	$R_S = 0\Omega$		-2.0	2.0	mV	1
				-4.0	4.0	mV	2, 3
		+V = 30V, $R_S = 0\Omega$		-2.0	2.0	mV	1
				-4.0	4.0	mV	2, 3
				-2.0	2.0	mV	1
+V = 30V, $V_{CM} = 28V$, $V_O = 1.4V$, $R_S = 0\Omega$		-2.0	2.0	mV	1		
		-4.0	4.0	mV	2, 3		
$\pm I_{IB}$	Input Bias Current	$V_O = 1.5V$	(Note 5)	-100	-1.0	nA	1
			(Note 5)	-300	-1.0	nA	2, 3
I_{IO}	Input Offset Current	$V_O = 1.5V$		-25	25	nA	1
				-100	100	nA	2, 3
PSRR	Power Supply Rejection Ratio	+V = 5V to 30V		70		dB	1, 2, 3
CMRR	Common Mode Rejection Ratio	+V = 30V, $V_{CM} = 0V$ to 28V, $R_L \geq 15K\Omega$		70		dB	1, 2, 3
A_V	Voltage Gain	+V = 15V, $R_L \geq 15K\Omega$, $V_O = 1V$ to 11V		50		V/mV	4
				25		V/mV	5, 6
V_{CM}	Common Mode Voltage Range	+V = 30V	(Note 9)	0	$V^+ - (2)$	V	1, 2, 3
		+V = 5V	(Note 9)	0	$V^+ - (2)$	V	1, 2, 3

AC Parameters

The following conditions apply, unless otherwise specified. +V = 5V

Symbol	Parameters	Conditions	Notes	Min	Max	Unit	Sub-groups
t_{RLH}	Response Time	$V_{OD} = 5mV$, $R_L = 5.1K\Omega$			5.0	μS	9
t_{RHL}	Response Time	$V_{OD} = 5mV$, $R_L = 5.1K\Omega$			2.5	μS	9

LM139A 883, QMLV & RH, SMD 5962–9673801 Electrical Characteristics

DC Parameters (Note 11)

The following conditions apply, unless otherwise specified. +V = 5V, $V_{CM} = 0V$

Symbol	Parameters	Conditions	Notes	Min	Max	Unit	Sub-groups
I_{CC}	Supply Current	$R_L = \text{Infinity}$			2.0	mA	1, 2, 3
		+V = 30V, $R_L = \text{Infinity}$			2.0	mA	1, 2, 3
I_{CEX}	Output Leakage Current	+V = 30V, $V_O = 30V$			1.0	μA	1, 2, 3
V_{Sat}	Saturation Voltage	$I_{Sink} = 4mA$			400	mV	1
					700	mV	2, 3
I_{Sink}	Output Sink Current	$V_O = 1.5V$		6.0		mA	1
V_{IO}	Input Offset Voltage			-2.0	2.0	mV	1
				-4.0	4.0	mV	2, 3
		+V = 30V		-2.0	2.0	mV	1
				-4.0	4.0	mV	2, 3
		+V = 30V, $V_{CM} = 28.5V$, $V_O = 1.5V$		-2.0	2.0	mV	1
	+V = 30V, $V_{CM} = 28.0V$, $V_O = 1.5V$		-4.0	4.0	mV	2, 3	
$\pm I_{Bias}$	Input Bias Current	$V_O = 1.5V$	(Note 5)	-100	-1.0	nA	1
			(Note 5)	-300	-1.0	nA	2, 3
I_{IO}	Input Offset Current	$V_O = 1.5V$		-25	25	nA	1
				-100	100	nA	2, 3
PSRR	Power Supply Rejection Ratio	+V = 5V to 30V		60		dB	1
CMRR	Common Mode Rejection Ratio	+V = 30V, $V_{CM} = 0V$ to 28.5V		60		dB	1
A_V	Voltage Gain	+V = 15V, $R_L \geq 15K\Omega$, $V_O = 1V$ to 11V		50		V/mV	1
V_{CM}	Common Mode Voltage Range	+V = 30V	(Note 9) (Note 12)	0	V ⁺ - (1.5)	V	1
			(Note 9) (Note 12)	0	V ⁺ - (1.5)	V	2, 3
V_{Diff}	Differential Input Voltage	+V = 30V, -V = 0V, +V _I = 36V, -V _I = 0V	(Note 10)		500	nA	1, 2, 3
		+V = 30V, -V = 0V, +V _I = 0V, -V _I = 36V	(Note 10)		500	nA	1, 2, 3

AC Parameters (Note 11)

The following conditions apply, unless otherwise specified. +V = 5V

Symbol	Parameters	Conditions	Notes	Min	Max	Unit	Sub-groups
t_{RLH}	Response Time	$V_{OD} = 5mV$			5.0	μS	4
		$V_{OD} = 50mV$			0.8	μS	4
t_{RHL}	Response Time	$V_{OD} = 5mV$			2.5	μS	4
		$V_{OD} = 50mV$			0.8	μS	4

LM139A 883, QMLV & RH, SMD 5962-9673801 Electrical Characteristics

(Continued)

DC Parameters Drift Values (Note 11)The following conditions apply, unless otherwise specified. +V = 5V, $V_{CM} = 0V$

Deltas required for S-Level, MLS (as specified on Internal Processing instructions (IPI)), and QMLV product at Group B, Sub-group 5.

Symbol	Parameters	Conditions	Notes	Min	Max	Unit	Sub-groups
V_{IO}	Input Offset Voltage			-1.0	1.0	mV	1
$\pm I_{Bias}$	Input Bias Current	$V_O = 1.5V$	(Note 5)	-15	15	nA	1
I_{IO}	Input Offset Current	$V_O = 1.5V$		-10	+10	nA	1

DC/AC Parameters 50K Post Rad Limits +25°C (Note 11)

The following conditions apply, unless otherwise specified.

DC: +V = 5V, $V_{CM} = 0V$

AC: +V = 5V

Symbol	Parameters	Conditions	Notes	Min	Max	Unit	Sub-groups
V_{IO}	Input Offset Voltage	+V = 5V, $V_{CM} = 0$		-2.5	2.5	mV	1
		+V = 30V, $V_{CM} = 0$		-2.5	2.5	mV	1
		+V = 30V, $V_{CM} = 28.5V$, $V_O = 1.5V$		-2.5	2.5	mV	1
$\pm I_{Bias}$	Input Bias Current	$V_O = 1.5V$	(Note 5)	-110	-1.0	nA	1
t_{RLH}	Response Time	V_{OD} (Overdrive) = 50mV			0.9	μS	4

DC/AC Parameters 100K Post Rad Limits +25°C (Note 11)

The following conditions apply, unless otherwise specified.

DC: +V = 5V, $V_{CM} = 0V$

AC: +V = 5V

Symbol	Parameters	Conditions	Notes	Min	Max	Unit	Sub-groups
V_{IO}	Input Offset Voltage	+V = 5V, $V_{CM} = 0$		-4.0	4.0	mV	1
		+V = 30V, $V_{CM} = 0$		-4.0	4.0	mV	1
		+V = 30V, $V_{CM} = 28.5V$, $V_O = 1.5V$		-4.0	4.0	mV	1
$\pm I_{Bias}$	Input Bias Current	$V_O = 1.5V$	(Note 5)	-110	-1.0	nA	1
t_{RLH}	Response Time	V_{OD} (Overdrive) = 50mV			1.0	μS	4

Notes:

Note 1: Absolute Maximum Ratings indicate limits beyond which damage to the device may occur. Operating Ratings indicate conditions for which the device is functional, but do not guarantee specific performance limits. For guaranteed specifications and test conditions, see, the Electrical Characteristics. The guaranteed specifications apply only for the test conditions listed. Some performance characteristics may degrade when the device is not operated under the listed test conditions.

Note 2: Short circuits from the output to V^+ can cause excessive heating and eventual destruction. When considering short circuits to ground, the maximum output current is approximately 20 mA independent of the magnitude of V^+ .

Note 3: This input current will only exist when the voltage at any of the input leads is driven negative. It is due to the collector-base junction of the input PNP transistors becoming forward biased and thereby acting as input diode clamps. In addition to this diode action, there is also lateral NPN parasitic transistor action on the IC chip. This transistor action can cause the output voltages of the comparators to go to the V^+ voltage level (or to ground for a large overdrive) for the time duration that an input is driven negative. This is not destructive and normal output states will re-establish when the input voltage, which was negative, again returns to a value greater than $-0.3 V_{DC}$ (at 25°C).

Note 4: The low bias dissipation and the ON-OFF characteristics of the outputs keeps the chip dissipation very small ($P_D \leq 100mW$), provided the output transistors are allowed to saturate.

Note 5: The direction of the input current is out of the IC due to the PNP input stage. This current is essentially constant, independent of the state of the output so no loading change exists on the reference or input lines.

Note 6: The input common-mode voltage or either input signal voltage should not be allowed to go negative by more than 0.3V. The upper end of the common-mode voltage range is $V^+ - 1.5V$ at 25°C, but either or both inputs can go to $+30 V_{DC}$ without damage, independent of the magnitude of V^+ .

Note 7: Short circuits from the output to V^+ can cause excessive heating and eventual destruction. When considering short circuits to ground, the maximum output current is approximately 20mA independent of the magnitude of V^+

Note 8: Positive excursions of input voltage may exceed the power supply level. As long as the other voltage remains within the common-mode range, the comparator will provide a proper output state. The low input voltage state must not be less than $-0.3 V_{DC}$ (or $0.3 V_{DC}$ below the magnitude of the negative power supply, if used) (at 25°C).

Note 9: Parameter guaranteed by V_{IO} tests

Note 10: The value for V_{Diff} is not data logged during Read and Record.

Note 11: Pre and post irradiation limits are identical to those listed under AC and DC electrical characteristics except as listed in the "Post Radiation Limits" table. These parts may be dose rate sensitive in a space environment and demonstrate enhanced low dose rate effect. Radiation end point limits for the noted parameters are guaranteed only for the conditions as specified in Mil-Std-883, Method 1019.

Note 12: The input common-mode voltage or either input signal voltage should not be allowed to go negative by more than 0.3V. The upper end of the common-mode voltage range is $V^+ - 1.5V$, but either or both inputs can go to $+30V_{DC}$ without damage independent of the magnitude of V^+ .

Note 13: SMD 5962-8773901 only

Note 14: Human Body model, 1.5 K Ω in series with 100 pF

Note 15: The maximum power dissipation must be derated at elevated temperatures and is dictated by T_{Jmax} (maximum junction temperature), θ_{JA} (Package junction to ambient thermal resistance), and T_A (ambient temperature). The maximum allowable power dissipation at any temperature is $P_{Dmax} = (T_{Jmax} - T_A) / \theta_{JA}$ or the number given in the Absolute Maximum Ratings, whichever is lower.

Typical Performance Characteristics LM139, LM139A

Supply Current

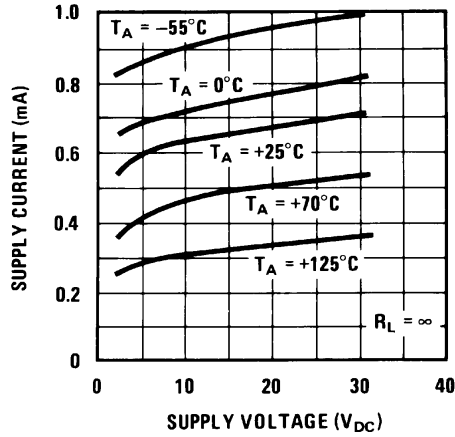

20122134

Input Current

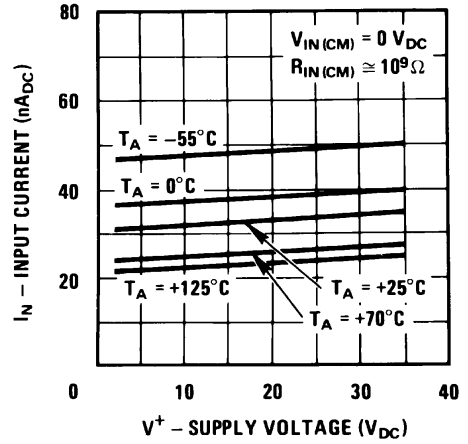

20122135

Output Saturation Voltage

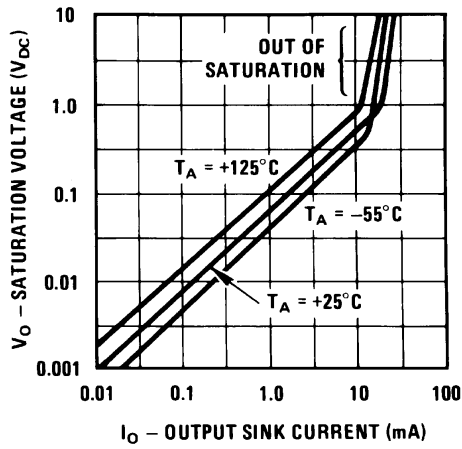

20122136

Response Time for Various Input Overdrives — Negative Transition

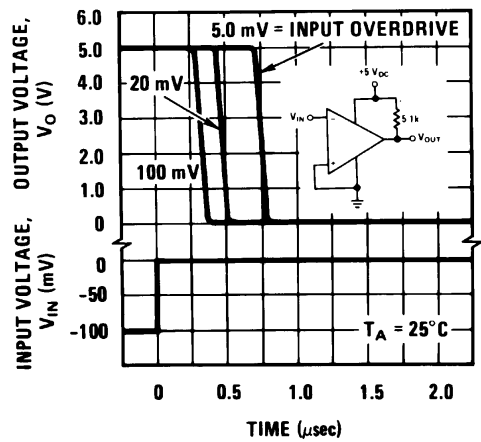

20122137

Response Time for Various Input Overdrives — Positive Transition

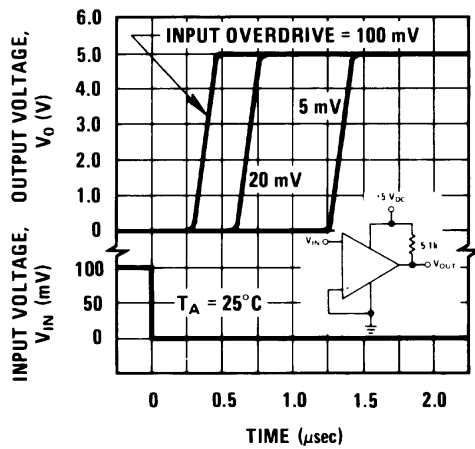

20122138

Application Hints

The LM139 series are high gain, wide bandwidth devices which, like most comparators, can easily oscillate if the output lead is inadvertently allowed to capacitively couple to the inputs via stray capacitance. This shows up only during the output voltage transition intervals as the comparator changes states. Power supply bypassing is not required to solve this problem. Standard PC board layout is helpful as it reduces stray input-output coupling. Reducing this input resistors to $< 10\text{ k}\Omega$ reduces the feedback signal levels and finally, adding even a small amount (1 to 10 mV) of positive feedback (hysteresis) causes such a rapid transition that oscillations due to stray feedback are not possible. Simply socketing the IC and attaching resistors to the pins will cause input-output oscillations during the small transition intervals unless hysteresis is used. If the input signal is a pulse waveform, with relatively fast rise and fall times, hysteresis is not required.

All pins of any unused comparators should be tied to the negative supply.

The bias network of the LM139 series establishes a drain current which is independent of the magnitude of the power supply voltage over the range of from 2 V_{DC} to 30 V_{DC} .

It is usually unnecessary to use a bypass capacitor across the power supply line.

The differential input voltage may be larger than V^+ without damaging the device. Protection should be provided to prevent the input voltages from going negative more than $-0.3\text{ V}_{\text{DC}}$ (at 25°C). An input clamp diode can be used as shown in the applications section.

The output of the LM139 series is the uncommitted collector of a grounded-emitter NPN output transistor. Many collectors can be tied together to provide an output OR'ing function. An output pull-up resistor can be connected to any available power supply voltage within the permitted supply voltage range and there is no restriction on this voltage due to the magnitude of the voltage which is applied to the V^+ terminal of the LM139A package. The output can also be used as a simple SPST switch to ground (when a pull-up resistor is not used). The amount of current which the output device can sink is limited by the drive available (which is independent of V^+) and the β of this device. When the maximum current limit is reached (approximately 16 mA), the output transistor will come out of saturation and the output voltage will rise very rapidly. The output saturation voltage is limited by the approximately $60\Omega\text{ R}_{\text{SAT}}$ of the output transistor. The low offset voltage of the output transistor (1 mV) allows the output to clamp essentially to ground level for small load currents.

Typical Applications $(V^+ = 5.0\text{ V}_{\text{DC}})$

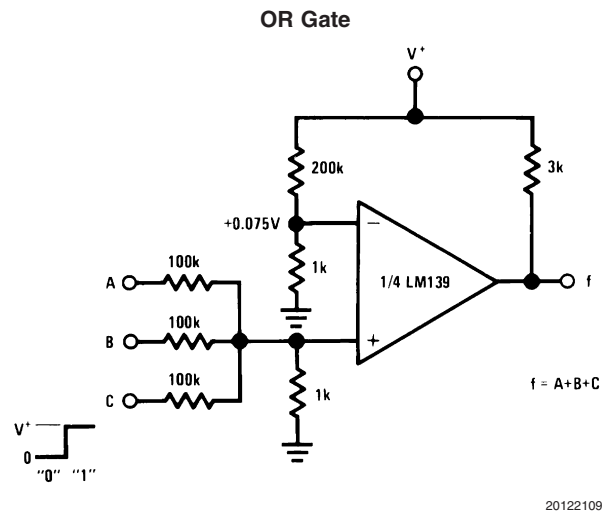
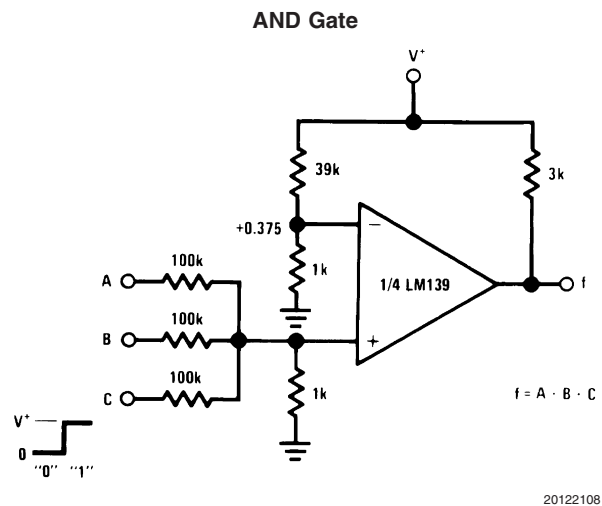
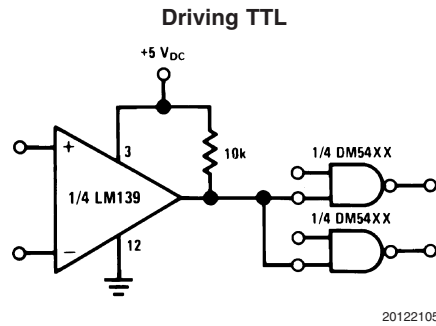
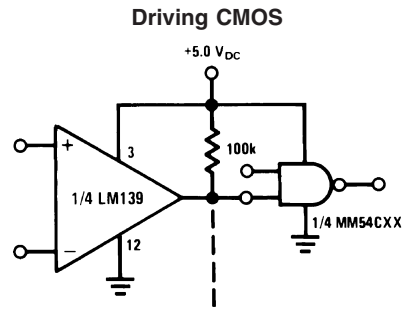
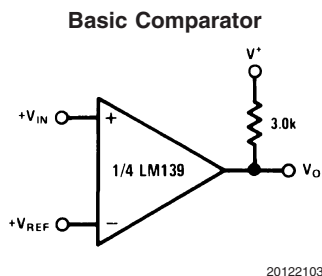

Typical Applications ($V^+ = 15\text{ V}_{\text{DC}}$)

One-Shot Multivibrator

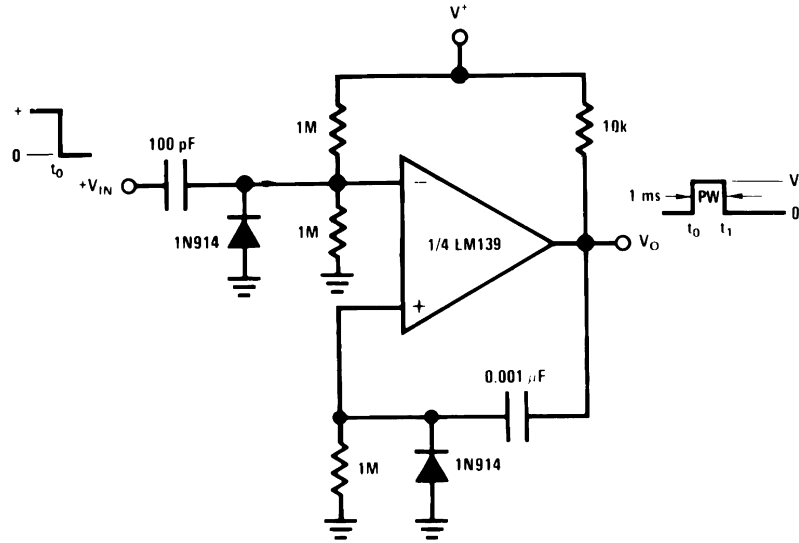

20122110

Bi-Stable Multivibrator

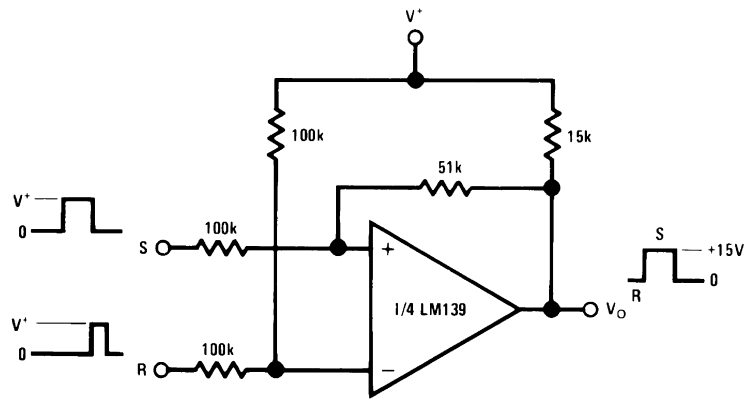

20122111

Typical Applications ($V^+ = 15\text{ V}_{DC}$) (Continued)

One-Shot Multivibrator with Input Lock Out

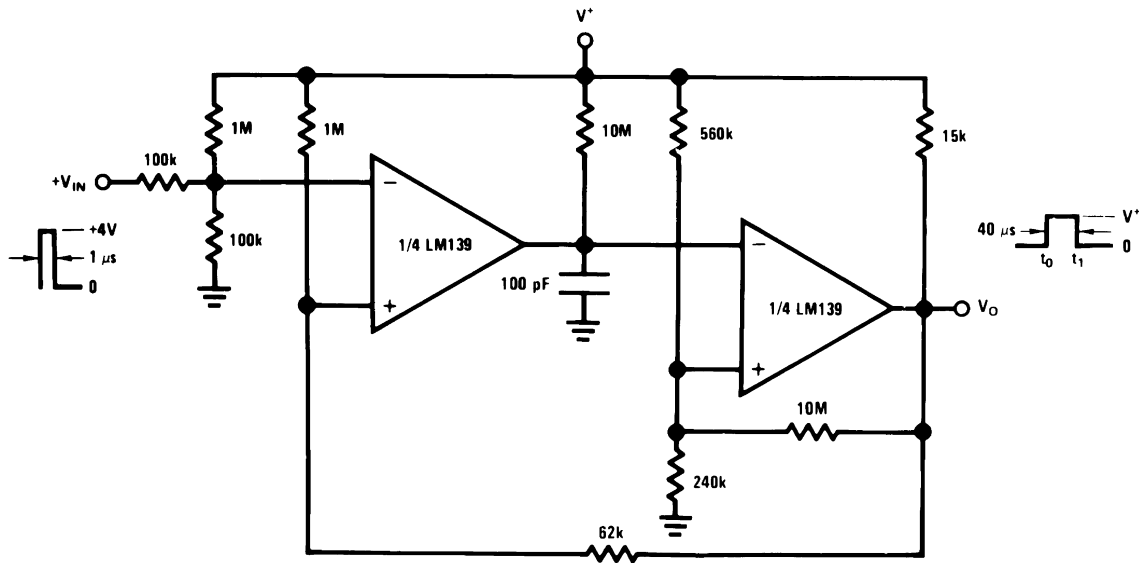

20122112

Pulse Generator

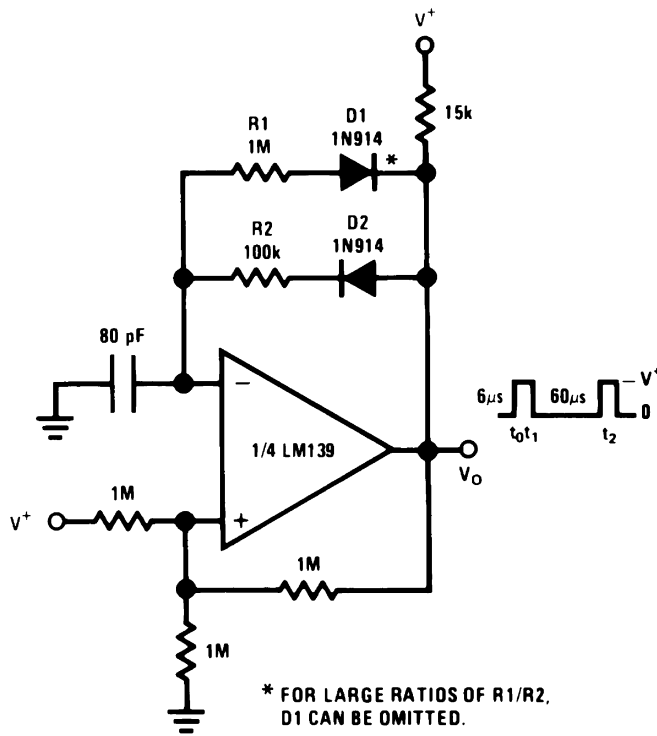

* FOR LARGE RATIOS OF $R1/R2$,
D1 CAN BE OMITTED.

20122117

Typical Applications $(V^+ = 15 V_{DC})$ (Continued)

Large Fan-In AND Gate

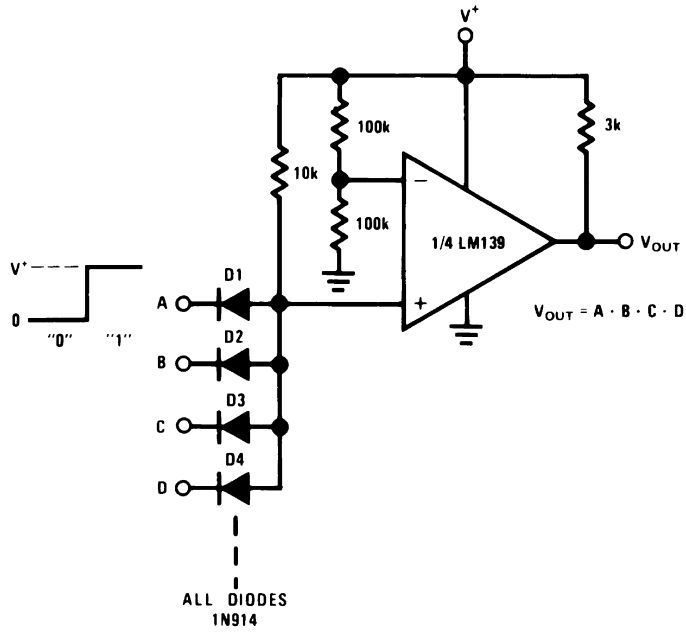

20122113

ORing the Outputs

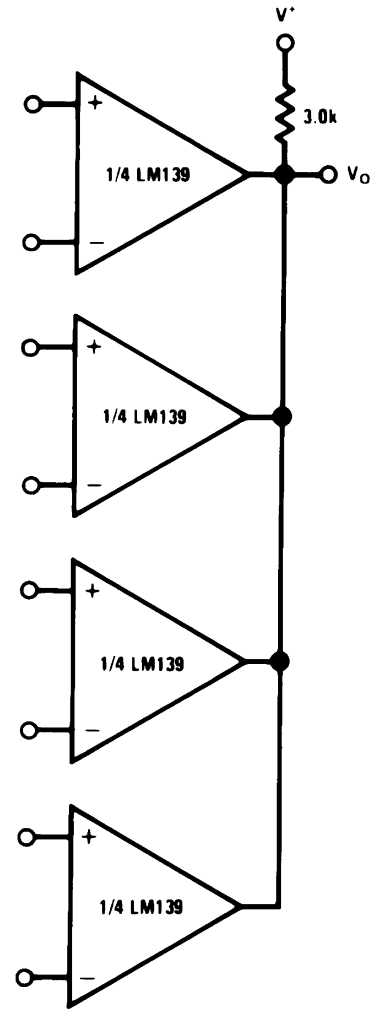

20122115

Typical Applications ($V^+ = 15 V_{DC}$) (Continued)

Squarewave Oscillator

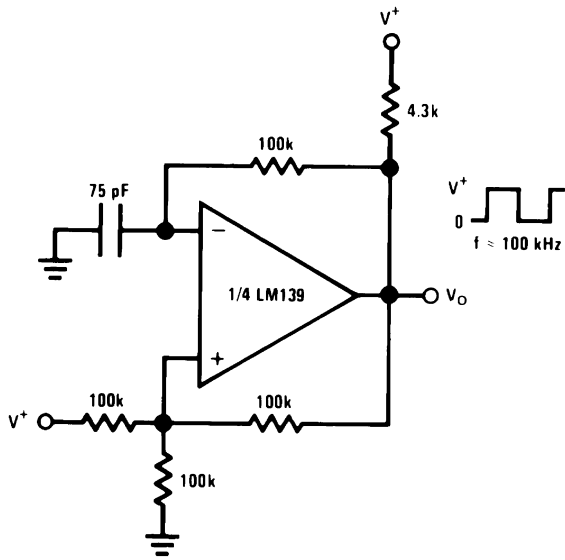

20122116

Basic Comparator

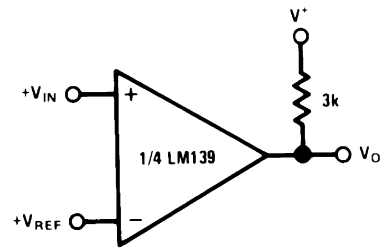

20122121

Limit Comparator

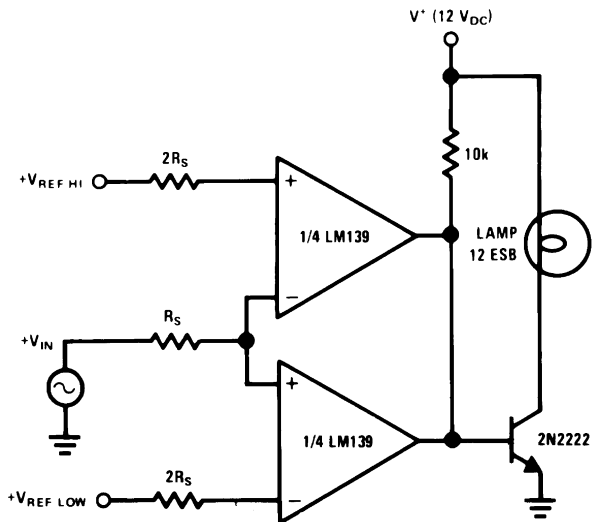

20122124

Comparing Input Voltages of Opposite Polarity

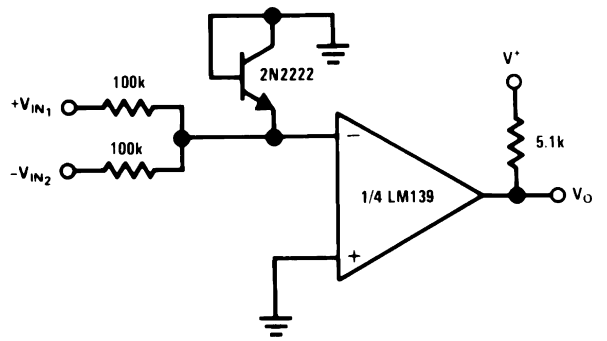

20122120

Typical Applications ($V^+ = 15 V_{DC}$) (Continued)

Output Strobing

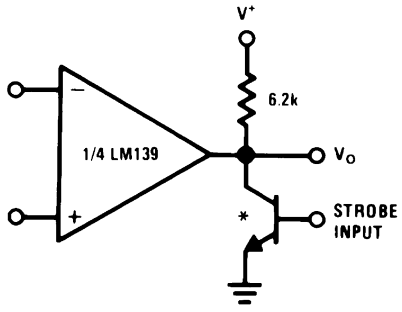

20122122

* Or open-collector logic gate without pull-up resistor

Crystal Controlled Oscillator

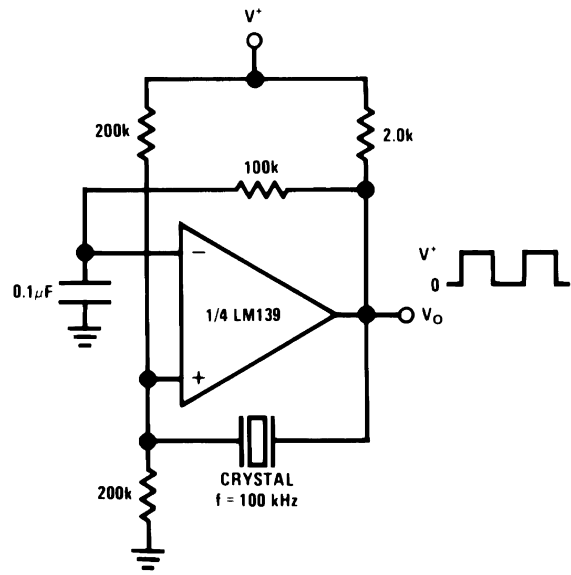

20122125

Typical Applications ($V^+ = 15 V_{DC}$) (Continued)

Two-Decade High-Frequency VCO

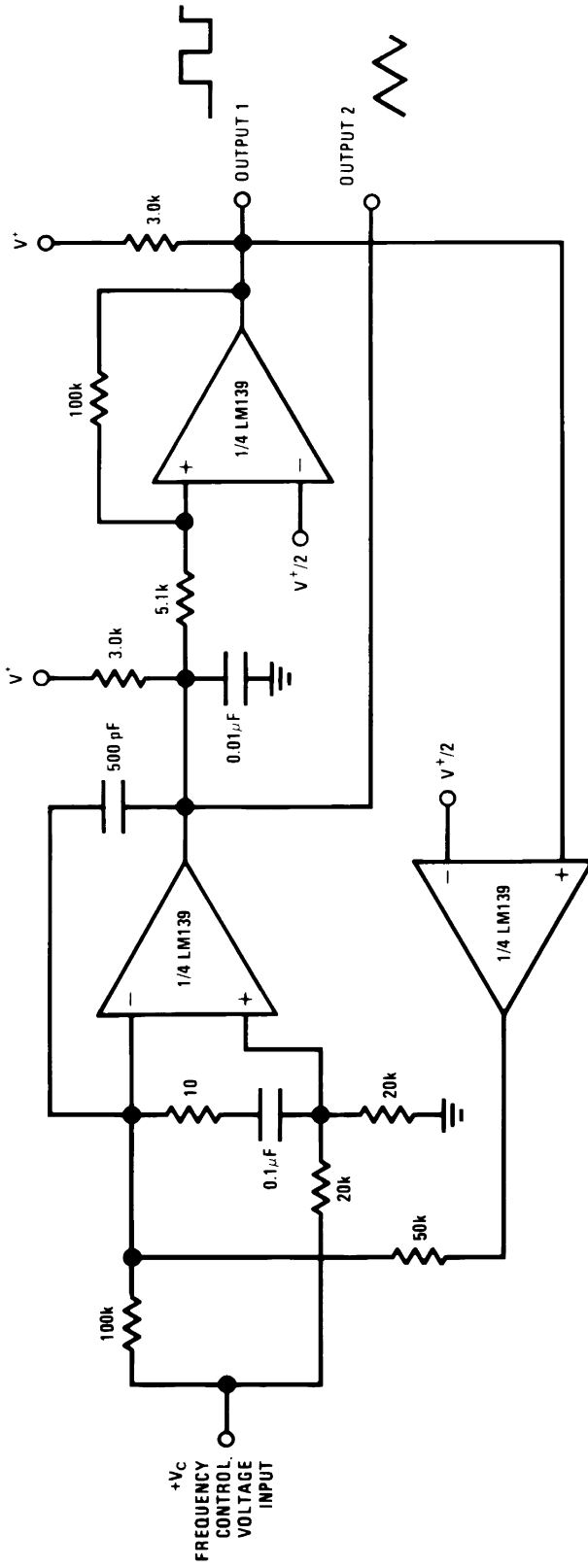

$V^+ = +50 V_{DC}$
 $250 mV_{DC} \leq V_C \leq +50 V_{DC}$
 $700 Hz \leq f_o \leq 100 kHz$

20122123

Typical Applications ($V^+ = 15\text{ V}_{DC}$) (Continued)

Transducer Amplifier

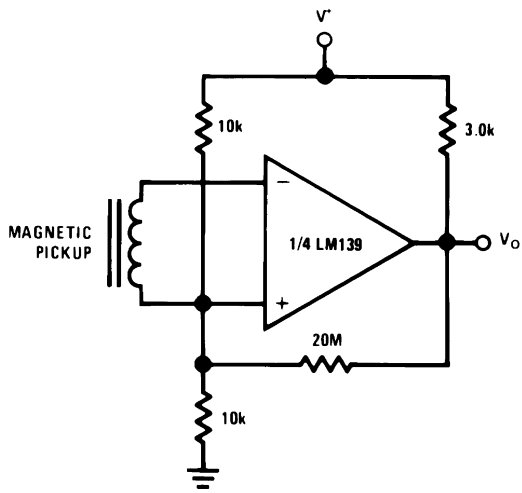

20122128

Zero Crossing Detector (Single Power Supply)

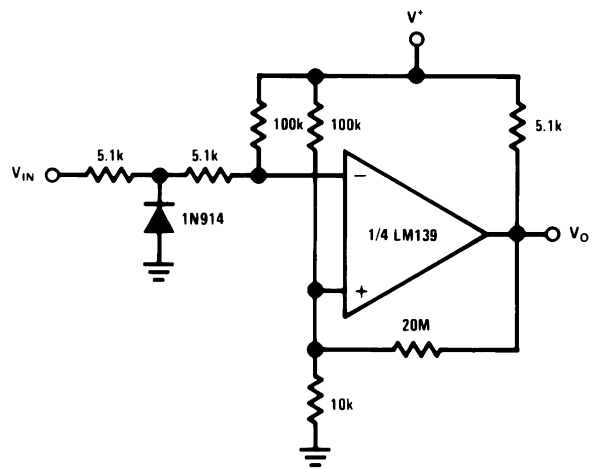

20122130

Split-Supply Applications ($V^+ = +15\text{ V}_{DC}$ and $V^- = -15\text{ V}_{DC}$)

MOS Clock Driver

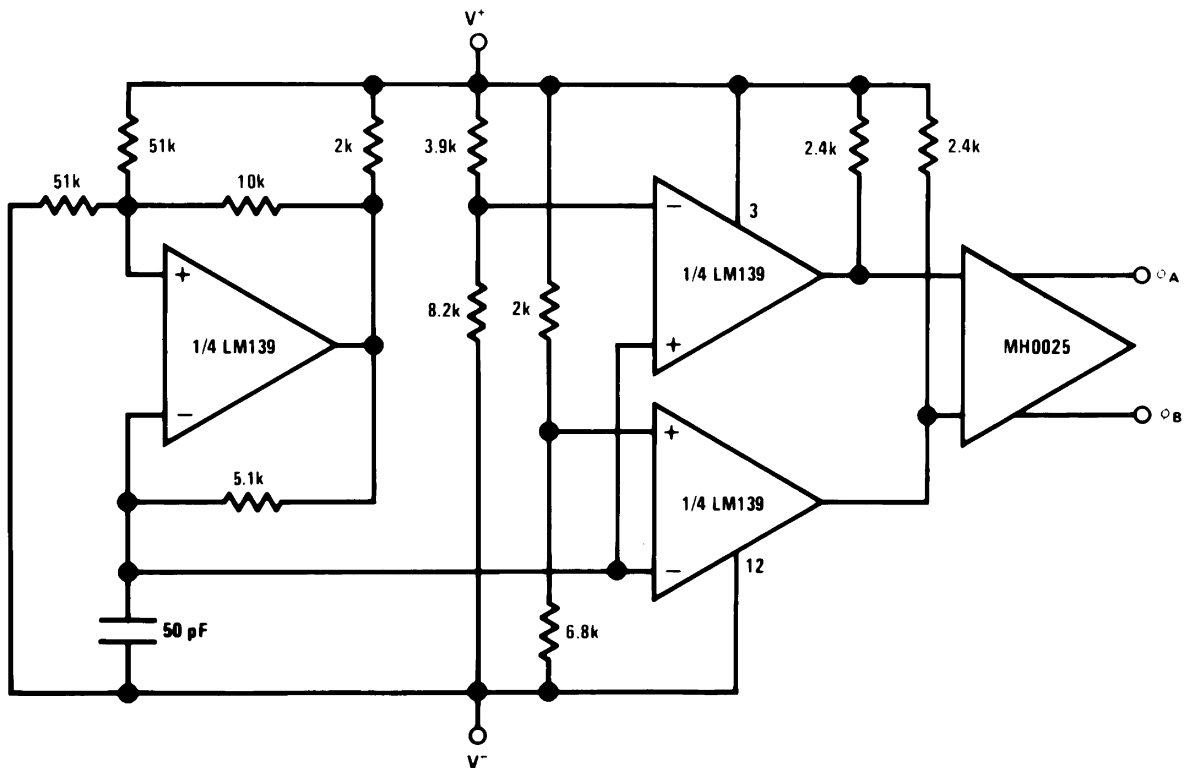

20122131

Split-Supply Applications ($V^+ = +15 V_{DC}$ and $V^- = -15 V_{DC}$) (Continued)

Zero Crossing Detector

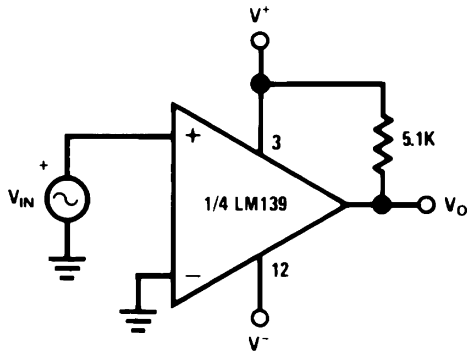

20122132

Comparator With a Negative Reference

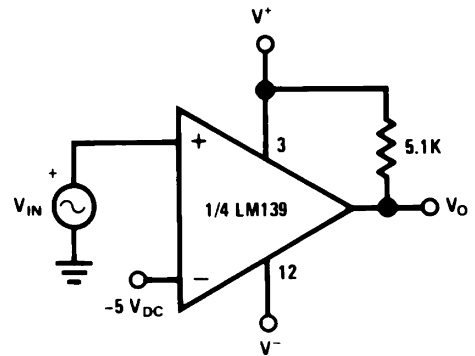

20122133

Schematic Diagram

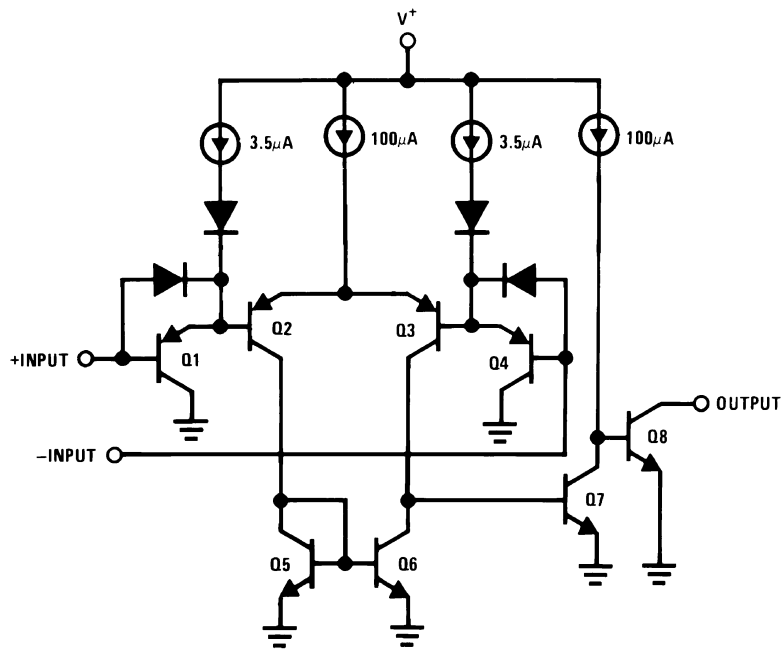

20122101

Revision History Section

Date Released	Revision	Section	Originator	Changes
02/08/05	A	New Release to corporate format	L. Lytle	3 MDS datasheets converted into one Corp. datasheet format. MNLM139A-X-RH rev 4B0, MDLM139A-X rev 0C1, MNLM139-X rev 1A1. MDS datasheets will be archived.

Physical Dimensions inches (millimeters) unless otherwise noted

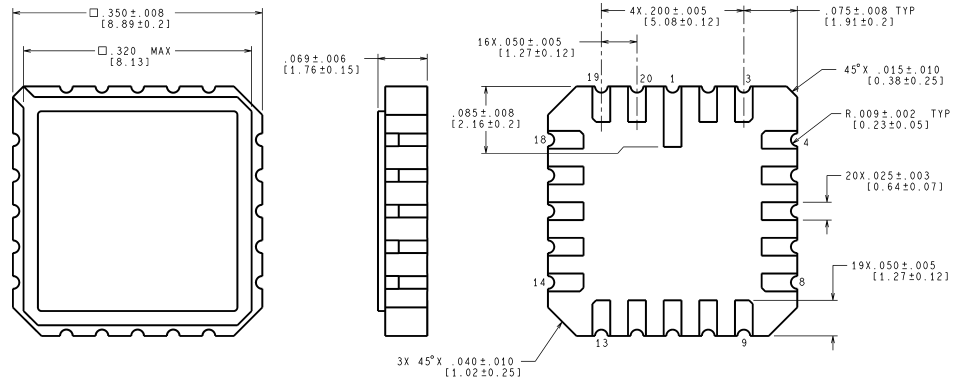

CONTROLLING DIMENSION IS INCH
VALUES IN [] ARE MILLIMETERS

E20A (Rev F)

**Leadless Chip Carrier (E)
NS Package Number E20A**

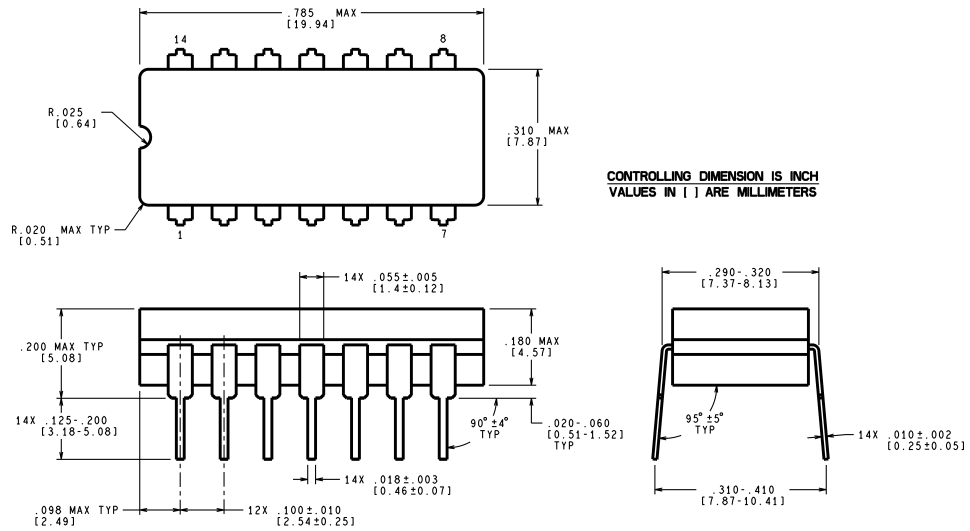

CONTROLLING DIMENSION IS INCH
VALUES IN [] ARE MILLIMETERS

J14A (Rev J)

**Ceramic Dual-In-Line Package (J)
NS Package Number J14A**

Notes

National does not assume any responsibility for use of any circuitry described, no circuit patent licenses are implied and National reserves the right at any time without notice to change said circuitry and specifications.

For the most current product information visit us at www.national.com.

LIFE SUPPORT POLICY

NATIONAL'S PRODUCTS ARE NOT AUTHORIZED FOR USE AS CRITICAL COMPONENTS IN LIFE SUPPORT DEVICES OR SYSTEMS WITHOUT THE EXPRESS WRITTEN APPROVAL OF THE PRESIDENT AND GENERAL COUNSEL OF NATIONAL SEMICONDUCTOR CORPORATION. As used herein:

1. Life support devices or systems are devices or systems which, (a) are intended for surgical implant into the body, or (b) support or sustain life, and whose failure to perform when properly used in accordance with instructions for use provided in the labeling, can be reasonably expected to result in a significant injury to the user.
2. A critical component is any component of a life support device or system whose failure to perform can be reasonably expected to cause the failure of the life support device or system, or to affect its safety or effectiveness.

BANNED SUBSTANCE COMPLIANCE

National Semiconductor manufactures products and uses packing materials that meet the provisions of the Customer Products Stewardship Specification (CSP-9-111C2) and the Banned Substances and Materials of Interest Specification (CSP-9-111S2) and contain no "Banned Substances" as defined in CSP-9-111S2.



National Semiconductor
Americas Customer
Support Center
Email: new.feedback@nsc.com
Tel: 1-800-272-9959

www.national.com

National Semiconductor
Europe Customer Support Center
Fax: +49 (0) 180-530 85 86
Email: europe.support@nsc.com
Deutsch Tel: +49 (0) 69 9508 6208
English Tel: +44 (0) 870 24 0 2171
Français Tel: +33 (0) 1 41 91 8790

National Semiconductor
Asia Pacific Customer
Support Center
Email: ap.support@nsc.com

National Semiconductor
Japan Customer Support Center
Fax: 81-3-5639-7507
Email: jpn.feedback@nsc.com
Tel: 81-3-5639-7560