

# DS96F173M/DS96F175C/DS96F175M

## EIA-485/EIA-422 Quad Differential Receivers

### General Description

The DS96F173 and the DS96F175 are high speed quad differential line receivers designed to meet the EIA-485 standard. The DS96F173 and the DS96F175 offer improved performance due to the use of L-FAST bipolar technology. The use of LFAST technology allows the DS96F173 and DS96F175 to operate at higher speeds while minimizing power consumption.

The DS96F173 and the DS96F175 have TRI-STATE® outputs and are optimized for balanced multipoint data bus transmission at rates up to 15 Mbps. The receivers feature high input impedance, input hysteresis for increased noise immunity, and input sensitivity of 200 mV over a common mode input voltage range of -7V to +12V. The receivers are therefore suitable for multipoint applications in noisy environments. The DS96F173 features an active high and active low Enable, common to all four receivers. The DS96F175 features separate active high Enables for each receiver pair.

- Common mode input voltage range: -7V to +12V
- Operates from single +5.0V supply
- Reduced power consumption ( $I_{CC} = 50$  mA max)
- Input sensitivity of  $\pm 200$  mV over common mode range
- Input hysteresis of 50 mV typical
- High input impedance
- Military temperature range available
- Qualified for MIL STD 883C
- Available to standard military drawings (SMD)
- Available in DIP(J), LCC(E), and FlatPak (W) packages
- DS96F173 and DS96F175 are lead and function compatible with SN75173/175 or the AM26LS32/MC3486

### Features

- Meets EIA-485, EIA-422A, EIA-423A standards
- Designed for multipoint bus applications
- TRI-STATE outputs

### Logic Diagrams

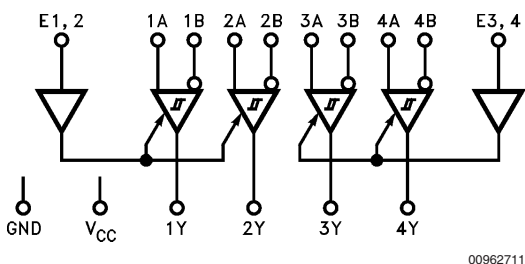
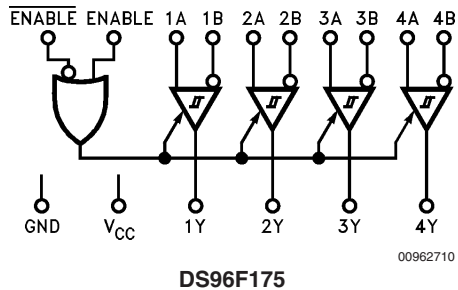

### Function Tables

(Each Receiver) DS96F173

Differential Inputs A-B	Enable E $\bar{E}$		Output Y
$V_{ID} \geq 0.2V$	H	X	H
	X	L	H
$V_{ID} \leq -0.2V$	H	X	L
	X	L	L
X	L	X	Z
X	X	H	Z

H = High Level  
L = Low Level  
Z = High Impedance (off)  
X = Don't Care

(Each Receiver) DS96F175

Differential Inputs A-B	Enable E	Output Y
$V_{ID} \geq 0.2V$	H	H
$V_{ID} \leq -0.2V$	H	L
X	L	Z

TRI-STATE® is a registered trademark of National Semiconductor Corporation.

**Absolute Maximum Ratings****COMMERCIAL** (Note 2)

Specifications for the 883 version of this product are listed separately.

Storage Temperature Range ( $T_{STG}$ )	-65°C to +175°C
Lead Temperature (Soldering, 60 sec.)	300°C
Max. Package Power Dissipation (Note 1) at 25°C	
Ceramic DIP (J)	1500 mW
Supply Voltage	7.0V
Input Voltage, A or B Inputs	±25V
Differential Input Voltage	±25V
Enable Input Voltage	7.0V
Low Level Output Current	50 mA

**Recommended Operating Conditions**

	Min	Typ	Max	Units
Supply Voltage ( $V_{CC}$ ) DS96F175C	4.75	5.0	5.25	V
Common Mode Input Voltage ( $V_{CM}$ )	-7		+12	V
Differential Input Voltage ( $V_{ID}$ )		12	1	V
Output Current HIGH ( $I_{OH}$ )			-400	µA
Output Current LOW ( $I_{OL}$ )			11	mA
Operating Temperature ( $T_A$ ) DS96F175C	0	25	70	°C

Note 1: Derate package 10 mW/°C above 25°C.

**Electrical Characteristics** (Notes 3, 4)

Over recommended supply voltage and operating temperature ranges, unless otherwise specified

Symbol	Parameter	Conditions	Min	Typ	Max	Units
$V_{TH}$	Differential-Input High Threshold Voltage	$V_O = V_{OH}$			0.2	V
$V_{TL}$	Differential-Input (Note 5) Low Threshold Voltage	$V_O = V_{OL}$	-0.2			V
$V_{TH} - V_{TL}$	Hysteresis (Note 6)	$V_{CM} = 0V$		50		mV
$V_{IH}$	Enable Input Voltage HIGH		2.0			V
$V_{IL}$	Enable Input Voltage LOW				0.8	V
$V_{IC}$	Enable Input Clamp Voltage	$I_I = -18$ mA			-1.5	V
$V_{OH}$	Output Voltage HIGH	$V_{ID} = 200$ mV	0°C to +70°C	2.8		V
		$I_{OH} = -400$ µA	-55°C to +125°C	2.5		
$V_{OL}$	Output Voltage LOW	$V_{ID} = -200$ mV	$I_{OL} = 8.0$ mA		0.45	V
			$I_{OL} = 11$ mA		0.50	
$I_{OZ}$	High-Impedance State Output	$V_O = 0.4V$ to 2.4V			±20	µA
$I_I$	Line Input Current (Note 7)	Other Input = 0V	$V_I = 12V$		1.0	mA
			$V_I = -7.0V$		-0.8	
$I_{IH}$	Enable Input Current HIGH	$V_{IH} = 2.7V$			20	µA
$I_{IL}$	Enable Input Current LOW	$V_{IL} = 0.4V$			-100	µA
$R_I$	Input Resistance		14	18	22	kΩ
$I_{OS}$	Short Circuit Output Current	(Note 8)	-15		-85	mA
$I_{CC}$	Supply Current	No Load	Outputs Enabled		50	mA
			Outputs Disabled		50	

**COMMERCIAL****Switching Characteristics** $V_{CC} = 5.0V$ ,  $T_A = 25^\circ C$ 

Symbol	Parameter	Conditions	Min	Typ	Max	Units
$t_{PLH}$	Propagation Delay Time, Low to High Level Output	$V_{ID} = -2.5V$ to $+2.5V$ , $C_L = 15$ pF, <i>Figure 1</i> $V_{CM} = 0V$	5.0	15	22	ns
$t_{PHL}$	Propagation Delay Time, High to Low Level Output		5.0	15	22	ns
$t_{ZH}$	Output Enable Time to High Level	$C_L = 15$ pF, <i>Figure 2</i>		12	16	ns
$t_{ZL}$	Output Enable Time to Low Level	$C_L = 15$ pF, <i>Figure 3</i>		13	18	ns
$t_{HZ}$	Output Disable Time from High Level	$C_L = 5.0$ pF, <i>Figure 2</i>		14	20	ns
$t_{LZ}$	Output Disable Time from Low Level	$C_L = 5.0$ pF, <i>Figure 3</i>		14	18	ns
$ t_{PLH} - t_{PHL} $	Pulse Width Distortion (SKEW)	<i>Figure 1</i>		1.0	3.0	ns

**Note 2:** "Absolute Maximum Ratings" are those values beyond which the safety of the device cannot be guaranteed. They are not meant to imply that the devices should be operated at these limits. The tables of "Electrical Characteristics" provide conditions for actual device operation.

**Note 3:** Unless otherwise specified min/max limits apply across the  $0^\circ C$  to  $+70^\circ C$  range for the DS96F175C. All typicals are given for  $V_{CC} = 5V$  and  $T_A = 25^\circ C$ .

**Note 4:** All currents into the device pins are positive; all currents out of the device pins are negative. All voltages are reference to ground unless otherwise specified.

**Note 5:** The algebraic convention, when the less positive (more negative) limit is designated minimum, is used in this data sheet for common mode input voltage and threshold voltage levels only.

**Note 6:** Hysteresis is the difference between the positive-going input threshold voltage,  $V_{TH}$ , and the negative going input threshold voltage,  $V_{TL}$ .

**Note 7:** Refer to EIA-485 Standard for exact conditions.

**Note 8:** Only one output at a time should be shorted.

**Order Number: DS96F175CJ**

**See NS Package Number J16A**

## MIL-STD-883C

### Absolute Maximum Ratings (Note 2)

For complete Military Specifications, refer to the appropriate SMD or MDS.

Storage Temperature Range (T <sub>STG</sub> )	-65°C to +175°C
Lead Temperature (Soldering, 60 sec.)	300°C
Max. Package Power Dissipation (Note 9) at 25°C	

Ceramic DIP (J)	1500 mW
Ceramic Flatpak (W)	1034 mW
Ceramic LCC (E)	1500 mW
Supply Voltage	7.0V
Input Voltage, A or B Inputs	±25V
Differential Input Voltage	±25V
Enable Input Voltage	7.0V
Low Level Output Current	50 mA

### Recommended Operating Conditions

	Min	Typ	Max	Units		Min	Typ	Max	Units
Supply Voltage (V <sub>CC</sub> )					Output Current LOW (I <sub>OL</sub> )			11	mA
DS96F173M/DS96F175M	4.50	5.0	5.50	V	Operating Temperature (T <sub>A</sub> )				
Common Mode					DS96F173M/DS96F175M	-55	25	125	°C
Input Voltage (V <sub>CM</sub> )	-7		+12	V	<b>Note 9:</b> Above T <sub>A</sub> = 25°C derate J package 10 mW/°C, W package 6.90 mW/°C, E package 11.11 mW/°C.				
Differential Input Voltage (V <sub>ID</sub> )			12	V					
Output Current HIGH (I <sub>OH</sub> )			-400	µA					

### Electrical Characteristics (Notes 3, 4)

Over recommended supply voltage and operating temperature ranges, unless otherwise specified

Symbol	Parameter	Conditions	Min	Max	Units
V <sub>TH</sub>	Differential-Input High Threshold Voltage	V <sub>CC</sub> = 4.5V, 5.5V V <sub>CM</sub> = 0V, 12V, -12V		0.2	V
V <sub>TL</sub>	Differential-Input (Note 5) Low Threshold Voltage	V <sub>CC</sub> = 4.5V, 5.5V V <sub>CM</sub> = 0V, 12V, -12V	-0.2		V
V <sub>IH</sub>	Enable Input Voltage HIGH		2.0		V
V <sub>IL</sub>	Enable Input Voltage LOW			0.8	V
V <sub>IC</sub>	Enable Input Clamp Voltage	I <sub>I</sub> = -18 mA, V <sub>CC</sub> = 4.5V		-1.5	V
V <sub>OH</sub>	Output Voltage HIGH	V <sub>ID</sub> = 200 mV I <sub>OH</sub> = -400 µA -55°C to +125°C	2.5		V
V <sub>OL</sub>	Output Voltage LOW	V <sub>ID</sub> = -200 mV I <sub>OL</sub> = 8.0 mA		0.45	V
I <sub>OZ</sub>	High-Impedance State Output	V <sub>O</sub> = 0.4V, 2.4V, V <sub>CC</sub> = 5.5V		±20	µA
I <sub>I</sub>	Line Input Current (Note 7)	Other Input = 0V V <sub>I</sub> = 12V V <sub>I</sub> = -7.0V		1.0 -0.8	mA
I <sub>IH</sub>	Enable Input Current HIGH	V <sub>IH</sub> = 2.7V, V <sub>CC</sub> = 5.5V		20	µA
I <sub>IL</sub>	Enable Input Current LOW	V <sub>IL</sub> = 0.4V, V <sub>CC</sub> = 5.5V		-100	µA
R <sub>I</sub>	Input Resistance		10		kΩ
I <sub>OS</sub>	Short Circuit Output Current	(Note 8)	-15	-85	mA
I <sub>CC</sub>	Supply Current	No Load Outputs Enabled or Disabled		50	mA
I <sub>CCX</sub>					

## MIL-STD-883C

### Switching Characteristics

V<sub>CC</sub> = 5.0V

Symbol	Parameter	Conditions	T <sub>A</sub> = 25°C		T <sub>A</sub> = -55°C	T <sub>A</sub> = 125°C	Units
			Typ	Max	Max	Max	
t <sub>PLH</sub>	Propagation Delay Time, Low to High Level Output	V <sub>ID</sub> = -2.5V to +2.5V, C <sub>L</sub> = 15 pF, <i>Figure 1</i>	15	22	30	30	ns
t <sub>PHL</sub>	Propagation Delay Time,	V <sub>CM</sub> = 0V	15	22	30	30	ns

**MIL-STD-883C** (Continued)

**Switching Characteristics** (Continued)

V<sub>CC</sub> = 5.0V

Symbol	Parameter	Conditions	T <sub>A</sub> = 25°C		T <sub>A</sub> = -55°C	T <sub>A</sub> = 125°C	Units
			Typ	Max	Max	Max	
	High to Low Level Output						
t <sub>ZH</sub>	Output Enable Time to High Level	C <sub>L</sub> = 15 pF, <i>Figure 2</i>	12	16	27	27	ns
t <sub>ZL</sub>	Output Enable Time to Low Level	C <sub>L</sub> = 15 pF, <i>Figure 3</i>	13	18	27	27	ns
t <sub>HZ</sub>	Output Disable Time from High Level	C <sub>L</sub> = 5.0 pF, <i>Figure 2</i> (Note 15)	14	20	27	27	ns
		C <sub>L</sub> = 20 pF, <i>Figure 2</i> (Note 15)	14	30	37	37	ns
t <sub>LZ</sub>	Output Disable Time from Low Level	C <sub>L</sub> = 5.0 pF, <i>Figure 3</i>	14	18	30	30	ns
t <sub>PLH</sub> - t <sub>PHL</sub>	Pulse Width Distortion (SKEW)	<i>Figure 1</i>	1	3	5.0	5.0	ns

<b>SMD Number:</b>	<b>DS96F173MJ</b>	<b>5962-9076602 MEA</b>
	<b>DS96F173MW</b>	<b>5962-9076602 MFA</b>
	<b>DS96F173ME</b>	<b>5962-9076602 M2A</b>
	<b>DS96F175MJ</b>	<b>5962-9076601 MEA</b>
	<b>DS96F175MW</b>	<b>5962-9076601 MFA</b>
	<b>DS96F175ME</b>	<b>5962-9076601 M2A</b>

<b>Order Number:</b>	<b>883 Marking</b>	<b>SMD Marking</b>
	<b>DS96F173MJ/883</b>	<b>DS96F173MJ-SMD</b>
	<b>DS96F175MJ/883</b>	<b>DS96F175MJ-SMD</b>
	<b>See NS Package Number J16A</b>	
	<b>DS96F173ME/883</b>	<b>DS96F173ME-SMD</b>
	<b>DS96F175ME/883</b>	<b>DS96F175ME-SMD</b>
	<b>See NS Package Number E20A</b>	
	<b>DS96F173MW/883</b>	<b>DS96F173MW-SMD</b>
	<b>DS96F175MW/883</b>	<b>DS96F175MW-SMD</b>
	<b>See NS Package Number W16A</b>	

For complete Military Product Specifications, refer to the appropriate SMD or MDS.

## Connection Diagrams

16-Lead Ceramic Dual-In-Line Package  
NS Package Number J16A

DS96F173

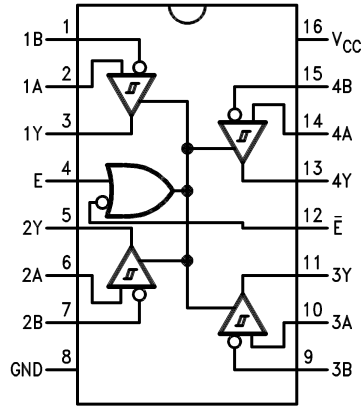

00962701

Top View

DS96F175

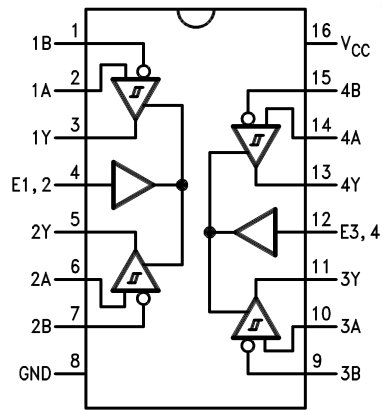

00962702

Top View

16-Lead Ceramic Flatpak  
NS Package Number W16A

20-Lead Ceramic Leadless Chip Carrier  
NS Package Number E20A

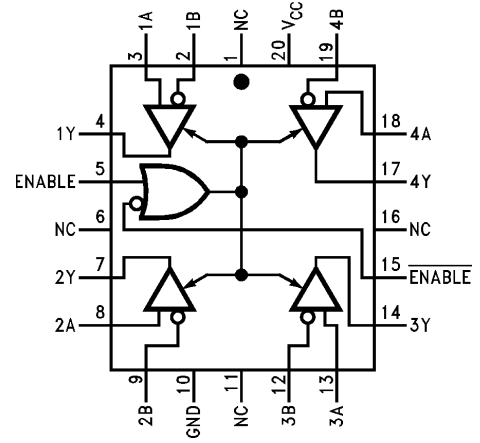

00962712

Top View

\*NC—No Connection

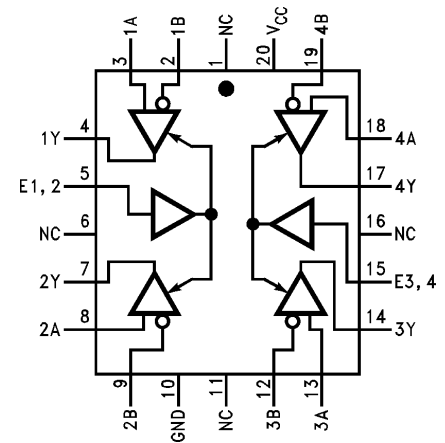

00962713

Top View

Connection Diagrams (Continued)

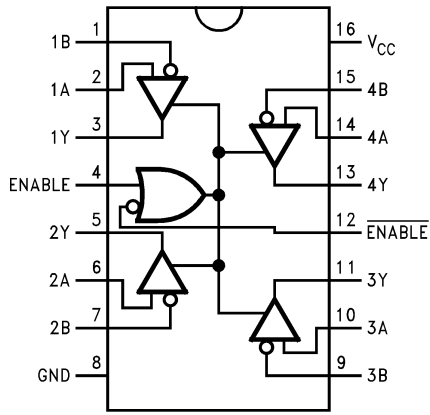

Top View

00962714

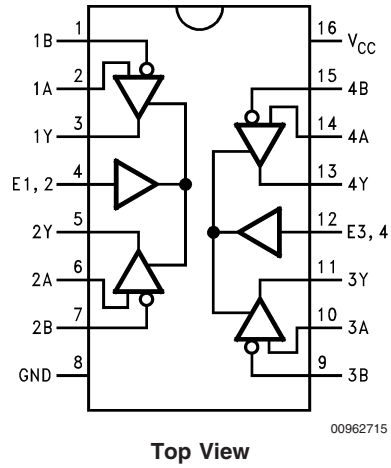

Top View

00962715

Order Numbers are located at the end of the respective Electrical Tables.

Parameter Measurement Information

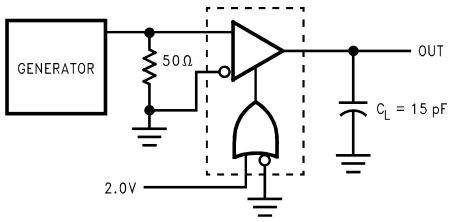

00962703

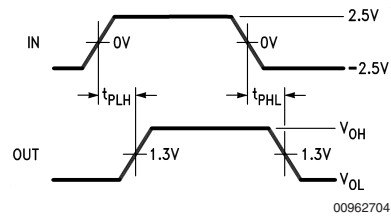

00962704

FIGURE 1.  $t_{PLH}$ ,  $t_{PHL}$  (Notes 10, 11)

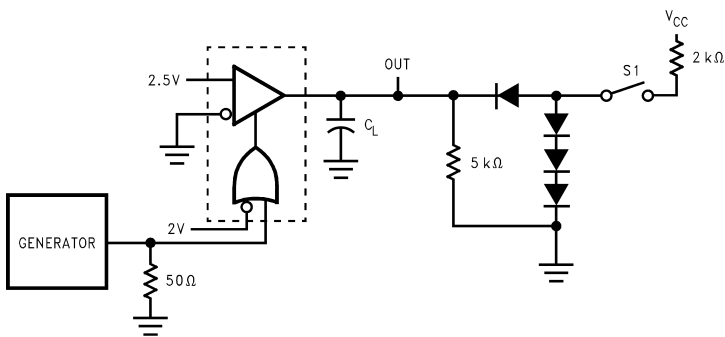

00962705

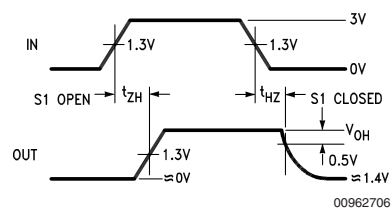

00962706

FIGURE 2.  $t_{HZ}$ ,  $t_{ZH}$  (Notes 10, 11, 13, 14)

## Parameter Measurement Information (Continued)

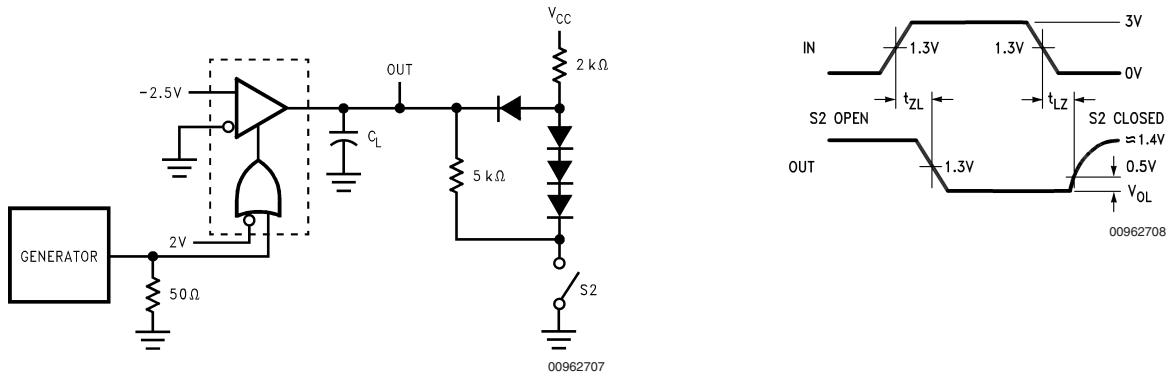

FIGURE 3.  $t_{ZL}$ ,  $t_{LZ}$  (Notes 10, 11, 13, 14)

**Note 10:** The input pulse is supplied by a generator having the following characteristics:  $f = 1.0$  MHz, 50% duty cycle,  $t_r \leq 6.0$  ns,  $t_f \leq 6.0$  ns,  $Z_O = 50\Omega$ .

**Note 11:**  $C_L$  includes probe and stray capacitance.

**Note 12:** DS96F173 with active high and active low Enables are shown. DS96F175 has active high Enable only.

**Note 13:** All diodes are 1N916 or equivalent.

**Note 14:** To test the active low Enable  $\bar{E}$  of DS96F173, ground E and apply an inverted input waveform to  $\bar{E}$ . DS96F175 has active high enable only.

**Note 15:** Testing at 20 pF assures conformance to 5 pF specification.

## Typical Application

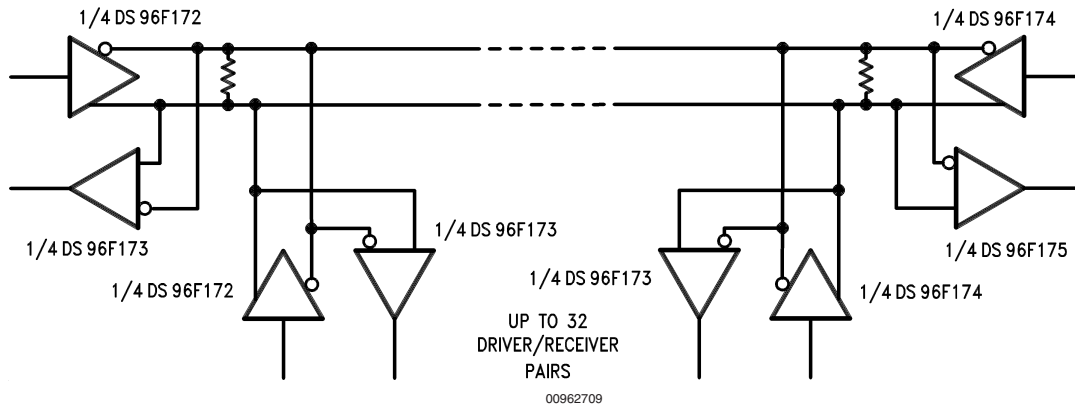
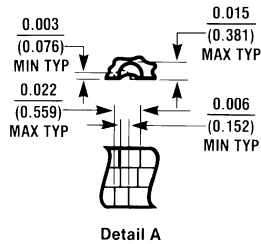
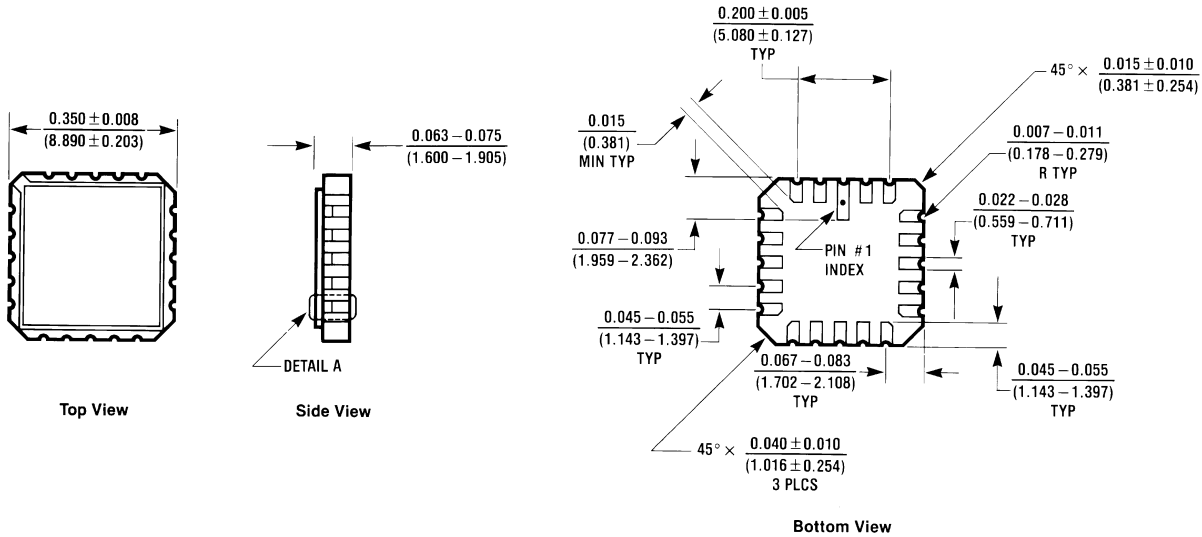

FIGURE 4.

**Note:** The line length should be terminated at both ends in its characteristic impedance. Stub lengths off the main line should be kept as short as possible.

**Physical Dimensions** inches (millimeters)

unless otherwise noted



E20A (REV D)

**20-Lead Ceramic Leadless Chip Carrier (E)**  
**Order Number DS96F173ME/883 or DS96F175ME/883**  
**NS Package Number E20A**

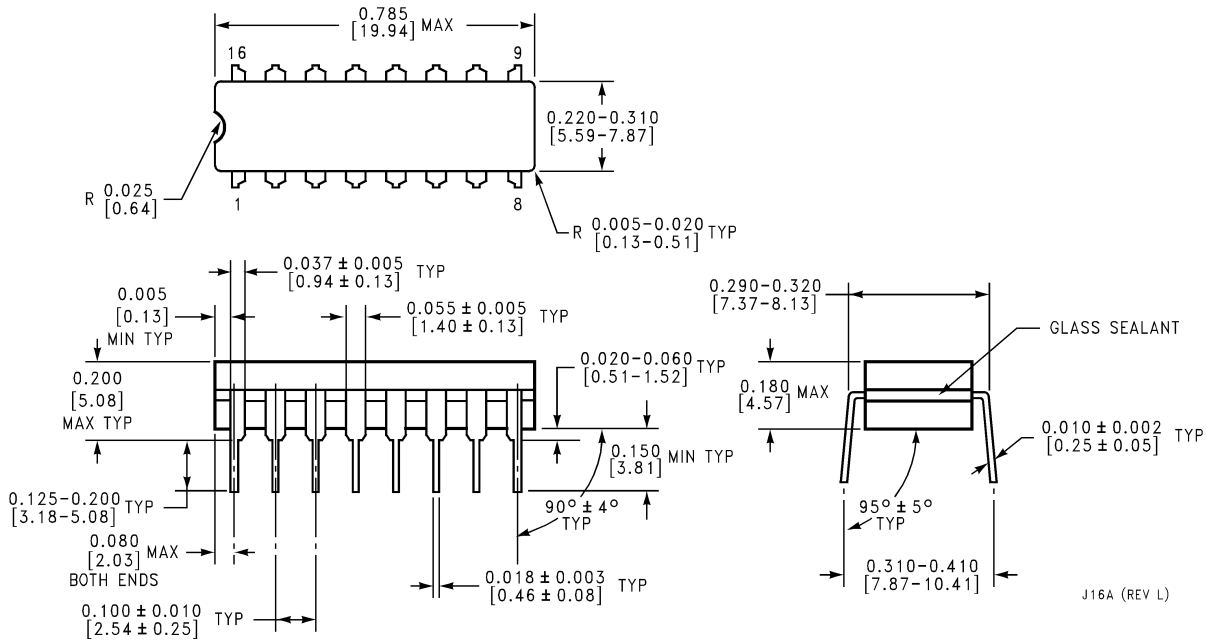

J16A (REV L)

**16-Lead Ceramic Dual-In-Line Package (J)**  
**Order Number DS96F175CJ, DS96F173MJ/883 or DS96F175MJ/883**  
**NS Package Number J16A**

**Physical Dimensions** inches (millimeters) unless otherwise noted (Continued)

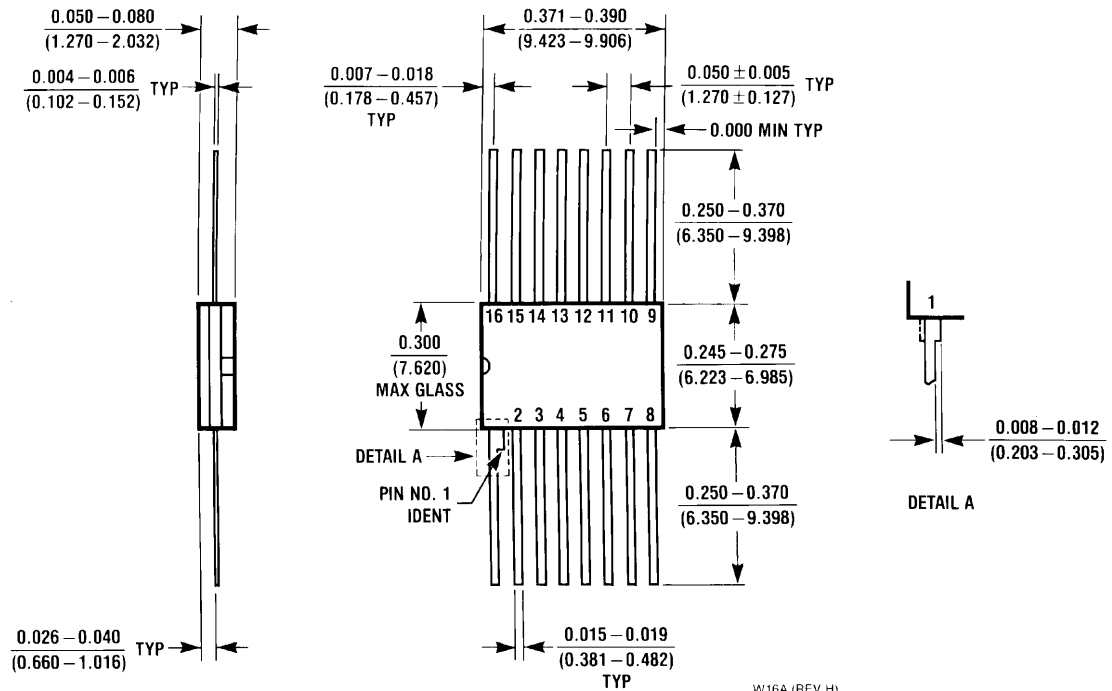

**16-Lead Ceramic FlatPak (W)**  
**Order Number DS96F173MW/883 or DS96F175MW/883**  
**NS Package Number W16A**

W16A (REV H)

National does not assume any responsibility for use of any circuitry described, no circuit patent licenses are implied and National reserves the right at any time without notice to change said circuitry and specifications.  
 For the most current product information visit us at [www.national.com](http://www.national.com).

**LIFE SUPPORT POLICY**

NATIONAL'S PRODUCTS ARE NOT AUTHORIZED FOR USE AS CRITICAL COMPONENTS IN LIFE SUPPORT DEVICES OR SYSTEMS WITHOUT THE EXPRESS WRITTEN APPROVAL OF THE PRESIDENT AND GENERAL COUNSEL OF NATIONAL SEMICONDUCTOR CORPORATION. As used herein:

1. Life support devices or systems are devices or systems which, (a) are intended for surgical implant into the body, or (b) support or sustain life, and whose failure to perform when properly used in accordance with instructions for use provided in the labeling, can be reasonably expected to result in a significant injury to the user.
2. A critical component is any component of a life support device or system whose failure to perform can be reasonably expected to cause the failure of the life support device or system, or to affect its safety or effectiveness.

**BANNED SUBSTANCE COMPLIANCE**

National Semiconductor certifies that the products and packing materials meet the provisions of the Customer Products Stewardship Specification (CSP-9-111C2) and the Banned Substances and Materials of Interest Specification (CSP-9-111S2) and contain no "Banned Substances" as defined in CSP-9-111S2.

 <p><b>National Semiconductor</b>  <b>Americas Customer Support Center</b>                  Email: <a href="mailto:new.feedback@nsc.com">new.feedback@nsc.com</a>                  Tel: 1-800-272-9959</p>	<p><b>National Semiconductor</b>  <b>Europe Customer Support Center</b>                  Fax: +49 (0) 180-530 85 86                  Email: <a href="mailto:europa.support@nsc.com">europa.support@nsc.com</a>                  Deutsch Tel: +49 (0) 69 9508 6208                  English Tel: +44 (0) 870 24 0 2171                  Français Tel: +33 (0) 1 41 91 8790</p>	<p><b>National Semiconductor</b>  <b>Asia Pacific Customer Support Center</b>                  Email: <a href="mailto:ap.support@nsc.com">ap.support@nsc.com</a></p>	<p><b>National Semiconductor</b>  <b>Japan Customer Support Center</b>                  Fax: 81-3-5639-7507                  Email: <a href="mailto:jpn.feedback@nsc.com">jpn.feedback@nsc.com</a>                  Tel: 81-3-5639-7560</p>
---	---	--	---