

**MNLM2940-15-X REV 1A1**

 Original Creation Date: 07/22/96  
 Last Update Date: 10/08/99  
 Last Major Revision Date: 07/22/96

**1A LOW DROPOUT REGULATOR**
**General Description**

The LM2940 positive voltage regulator features the ability to source 1A of output current with a dropout voltage of typically 0.5V and a maximum of 1V over the entire temperature range. Furthermore, a quiescent current reduction circuit has been included which reduces the ground current when the differential between the input voltage and the output voltage exceeds approximately 3V. The quiescent current with 1A of output current and an input-output differential of 5V is therefore only 30 mA. Higher quiescent currents only exist when the regulator is in the dropout mode ( $V_{in} - V_{out} \leq 3V$ ).

Designed also for vehicular applications, the LM2940 and all regulated circuitry are protected from reverse battery installations or 2-battery jumps. During line transients, such as load dump when the input voltage can momentarily exceed the specified maximum operating voltage, the regulator will automatically shut down to protect both the internal circuits and the load. The LM2940 cannot be harmed by temporary mirror-image insertion. Familiar regulator features such as short circuit and thermal overload protection are also provided.

**Industry Part Number**

LM2940

**NS Part Numbers**

 LM2940J-15/883  
 LM2940K-15/883  
 LM2940WG-15/883

**Prime Die**

LM2940

**Controlling Document**

SEE FEATURE SECTION

**Processing**

MIL-STD-883, Method 5004

**Quality Conformance Inspection**

MIL-STD-883, Method 5005

Subgrp	Description	Temp ( °C)
1	Static tests at	+25
2	Static tests at	+125
3	Static tests at	-55
4	Dynamic tests at	+25
5	Dynamic tests at	+125
6	Dynamic tests at	-55
7	Functional tests at	+25
8A	Functional tests at	+125
8B	Functional tests at	-55
9	Switching tests at	+25
10	Switching tests at	+125
11	Switching tests at	-55

**Features**

- Dropout voltage typically 0.5V @  $I_o = 1A$
- Output current in excess of 1A
- Output voltage trimmed before assembly
- Reverse battery protection
- Internal short circuit current limit
- Mirror image insertion protection
- CONTROLLING DOCUMENT
- LM2940J-15/883            5962-9088501QEA
- LM2940K-15/883            5962-9088501MYA
- LM2940WG-15/883         5962-9088501QXA

**(Absolute Maximum Ratings)**

(Note 1)

Input Voltage (Survival Voltage $\leq 100\text{ms}$ )	60V
Internal Power Dissipation (Note 2, 3)	Internally Limited
Maximum Junction Temperature	150 C
Storage Temperature Range	-65 C to +150 C
Lead Temperature (Soldering, 10 seconds)	300 C
Thermal Resistance	
ThetaJA	
T03 Pkg (Still Air)	40 C/W
T03 Pkg (500LF/Min Air Flow)	TBD
CERDIP (Still Air)	73 C/W
CERDIP (500LF/Min Air Flow)	37 C/W
CERAMIC SOIC (Still Air)	122 C/W
CERAMIC SOIC (500LF/Min Air Flow)	77 C/W
ThetaJC	
T03 Pkg	5 C/W
CERDIP	3 C/W
(Note 3)	
CERAMIC SOIC	5 C/W
(Note 3)	
Package Weight (Typical)	
T03 Pkg	TBD
CERDIP	1970mg
CERAMIC SOIC	360mg
ESD Susceptibility (Note 4)	4000V

Note 1: Absolute Maximum Ratings are limits beyond which damage to the device may occur. Operating Ratings are conditions for which the device is functional, but do not guarantee specific performance limits. For guaranteed specifications and test conditions see the Electrical Characteristics. The guaranteed specifications apply only for the test conditions listed. Some performance characteristics may degrade when the device is not operated under the listed test conditions.

Note 2: The maximum power dissipation must be derated at elevated temperatures and is dictated by  $T_{jmax}$  (maximum junction temperature),  $\theta_{JA}$  (package junction to ambient thermal resistance), and  $T_A$  (ambient temperature). The maximum allowable power dissipation at any temperature is  $P_{dmax} = (T_{jmax} - T_A)/\theta_{JA}$  or the number given in the Absolute Maximum Ratings, whichever is lower.

Note 3: The package material for these devices allows much improved heat transfer over our standard ceramic packages. In order to take full advantage of this improved heat transfer, heat sinking must be provided between the package base (directly beneath the die), and either metal traces on, or thermal vias through, the printed circuit board. Without this additional heat sinking, device power dissipation must be calculated using junction-to-ambient, rather than junction-to-case, thermal resistance. It must not be assumed that the device leads will provide substantial heat transfer out of the package, since the thermal resistance of the leadframe material is very poor, relative to the material of the package base. The stated junction-to-case thermal resistance is for the package material only, and does not account for the additional thermal resistance between the package base and the printed circuit board. The user must determine the value of the additional thermal resistance and must combine this with the stated value for the package, to calculate the total allowed power dissipation for the device.

Note 4: Human body model, 100pF discharged through 1.5K Ohms

## Recommended Operating Conditions

(Note 1)

Input Voltage

26V

Operating Temperature Range

$-55\text{ C} \leq T_A \leq +125\text{ C}$

Note 1: Absolute Maximum Ratings are limits beyond which damage to the device may occur. Operating Ratings are conditions for which the device is functional, but do not guarantee specific performance limits. For guaranteed specifications and test conditions see the Electrical Characteristics. The guaranteed specifications apply only for the test conditions listed. Some performance characteristics may degrade when the device is not operated under the listed test conditions.

## Electrical Characteristics

### DC PARAMETERS:

(The following conditions apply to all the following parameters, unless otherwise specified.)  
DC:  $V_{in} = 20V$ ,  $I_o = 1A$ ,  $C_{out} = 22\mu F$

SYMBOL	PARAMETER	CONDITIONS	NOTES	PIN-NAME	MIN	MAX	UNIT	SUB-GROUPS		
Vout	Output Voltage	$V_{in} = 20V$ , $I_o = 5mA$			14.55	15.45	V	1		
					14.25	15.75	V	2, 3		
		$V_{in} = 16.75V$ , $I_o = 5mA$			14.55	15.45	V	1		
					14.25	15.75	V	2, 3		
		$V_{in} = 17V$ , $I_o = 5mA$			14.55	15.45	V	1		
					14.25	15.75	V	2, 3		
		$V_{in} = 26V$ , $I_o = 5mA$			14.55	15.45	V	1		
					14.25	15.75	V	2, 3		
		$V_{in} = 20V$ , $I_o = 1A$			14.55	15.45	V	1		
					14.25	15.75	V	2, 3		
		$V_{in} = 16.75V$ , $I_o = 1A$			14.55	15.45	V	1		
					14.25	15.75	V	2, 3		
		$V_{in} = 16.75V$ , $I_o = 50mA$			14.55	15.45	V	1		
					14.25	15.75	V	2, 3		
		$V_{in} = 20V$ , $I_o = 50mA$			14.55	15.45	V	1		
					14.25	15.75	V	2, 3		
			Reverse Polarity Input Voltage DC	$R_o = 100 \text{ Ohms}$	1		-15		V	1, 2, 3
		Iq	Quiescent Current	$V_{in} = 20V$ , $I_o = 5mA$			0	15	mA	1
					0	20	mA	2, 3		
$V_{in} = 17V$ , $I_o = 5mA$					0	15	mA	1		
					0	20	mA	2, 3		
$V_{in} = 26V$ , $I_o = 5mA$					0	15	mA	1		
					0	20	mA	2, 3		
$V_{in} = 20V$ , $I_o = 1A$					0	50	mA	1		
					0	60	mA	2, 3		
Vrline	Line Regulation			$17V \leq V_{in} \leq 26V$ , $I_o = 5mA$			-95	95	mV	1
							-150	150	mV	2, 3
Vrload	Load Regulation	$V_{in} = 20V$ , $50mA \leq I_o \leq 1A$			-150	150	mV	1		
					-240	240	mV	2, 3		

## Electrical Characteristics

### DC PARAMETERS: (Continued)

(The following conditions apply to all the following parameters, unless otherwise specified.)  
DC:  $V_{in} = 20V$ ,  $I_o = 1A$ ,  $C_{out} = 22\mu F$

SYMBOL	PARAMETER	CONDITIONS	NOTES	PIN-NAME	MIN	MAX	UNIT	SUB-GROUPS
Vdo	Dropout Voltage	$I_o = 1A$			0	0.7	V	1
					0	1	V	2, 3
		$I_o = 100mA$			0	200	mV	1
					0	300	mV	2, 3
Isc	Short Circuit Current	$V_{in} = 20V$			1.6		A	1
					1.3		A	2, 3

### AC PARAMETERS:

(The following conditions apply to all the following parameters, unless otherwise specified.)  
AC:  $V_{in} = 20V$ ,  $I_o = 1A$ ,  $C_{out} = 22\mu F$

	Max Line Transient	$V_o \leq 16V$ , $R_o = 100 \text{ Ohms}$ , $T = 20ms$	1		40		V	7, 8A, 8B
	Reverse Polarity Input Voltage Transient	$T = 20ms$ , $R_o = 100 \text{ Ohms}$	1		-45		V	7, 8A, 8B
RR	Ripple Rejection	$V_{in} = 20V$ , $1V_{rms}$ , $f = 1KHz$ , $I_o = 5mA$	1		48		dB	4
					42		dB	5, 6
No	Output Noise Voltage	$V_{in} = 20V$ , $I_o = 5mA$ , $10Hz = 100KHz$	1		0	1000	$\mu V_{rms}$	4, 5, 6
Zo	Output Impedance	$V_{in} = 20V$ , $I_o = 100mA \text{ DC and } 20mA \text{ AC}$ , $f_o = 120Hz$	1			1	Ohm	4, 5, 6

Note 1: Functional test only.

## Graphics and Diagrams

GRAPHICS#	DESCRIPTION
05826HRA2	METAL CAN (KA), TO-3, 2LD, LOW PROFILE (B/I CKT)
06332HRA2	CERDIP (J), 16 LEAD (B/I CKT)
06351HRA1	CERPACK (W), 16 LEAD (B/I CKT)
J16ARL	CERDIP (J), 16 LEAD (P/P DWG)
K02CRE	METAL CAN (KA), TO-3, 2LD, LOW PROFILE (P/P DWG)
P000137A	METAL CAN (KA), TO-3, 2LD, LOW PROFILE (PINOUT)
P000159A	CERDIP (J), 16 LEAD (PINOUT)
P000386A	CERAMIC SOIC (WG), 16 LEAD (PINOUT)
WG16ARC	CERAMIC SOIC (WG), 16 LEAD (P/P DWG)

See attached graphics following this page.

R E V I S I O N S			
LTR	DESCRIPTION	E. C. N.	DATE
L	REVISE PER CURRENT STD; REDRAW	09996	09/15/93
			TL/

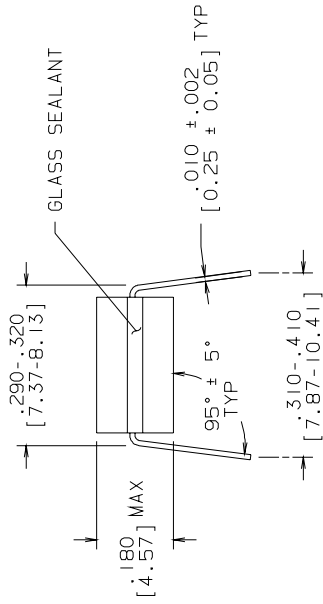
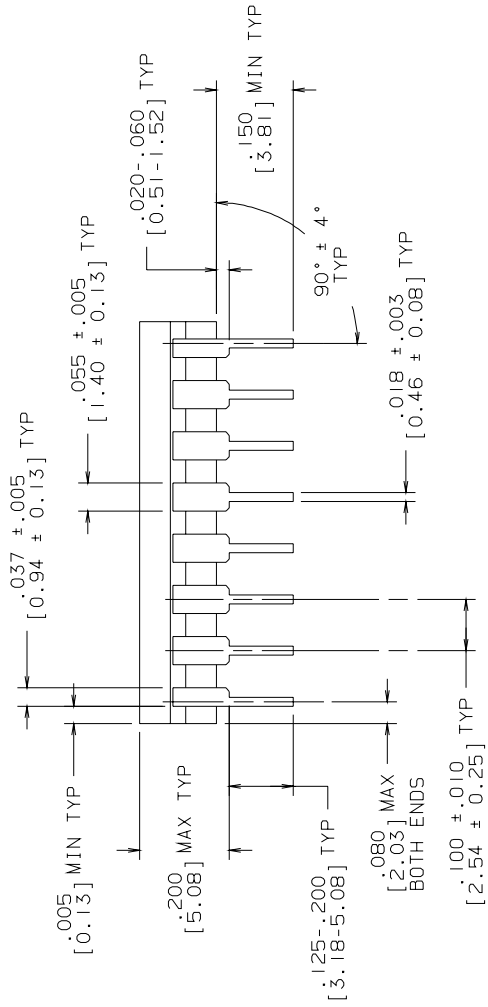
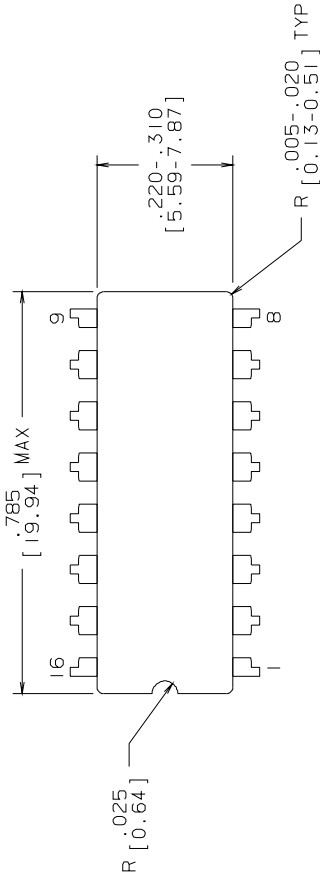

MIL/AERO  
CONFIGURATION CONTROL

MIL-M-38510  
CONFIGURATION CONTROL

CONTROLLING DIMENSION: INCH	
APPROVALS	DATE
DRAWN <b>T. LEQUANG</b>	09/15/93
DFTG. CHK.	
ENGR. CHK.	
APPROVAL	
PROJECTION 	
	INCH [MM]
SCALE N/A	SIZE B
DRAWING NUMBER MKT-J16A	REV L
DO NOT SCALE DRAWING	SHEET 1 OF 1

NATIONAL SEMICONDUCTOR CORPORATION  
2900 Semiconductor Drive, Santa Clara, CA 95052-8090

CERDIP (J),  
16 LEAD

NOTES: UNLESS OTHERWISE SPECIFIED

- LEAD FINISH TO BE 200 MICROMETERS / 5.08 MICROMETERS MINIMUM SOLDER MEASURED AT THE CREST OF THE MAJOR FLATS.
- JEDEC REGISTRATION MO-036, VARIATION AD, DATED 04/1981.

REVISIONS

LTR	DESCRIPTION	E.C.N.	DATE	BY/APP'D
E	REDRAW ON PROFILE: UPDATE MIL/AERO STAMP: NOTE 2: MIL-PRF-38535 WAS MIL-I-38535.	11155	09/15/95	MS/

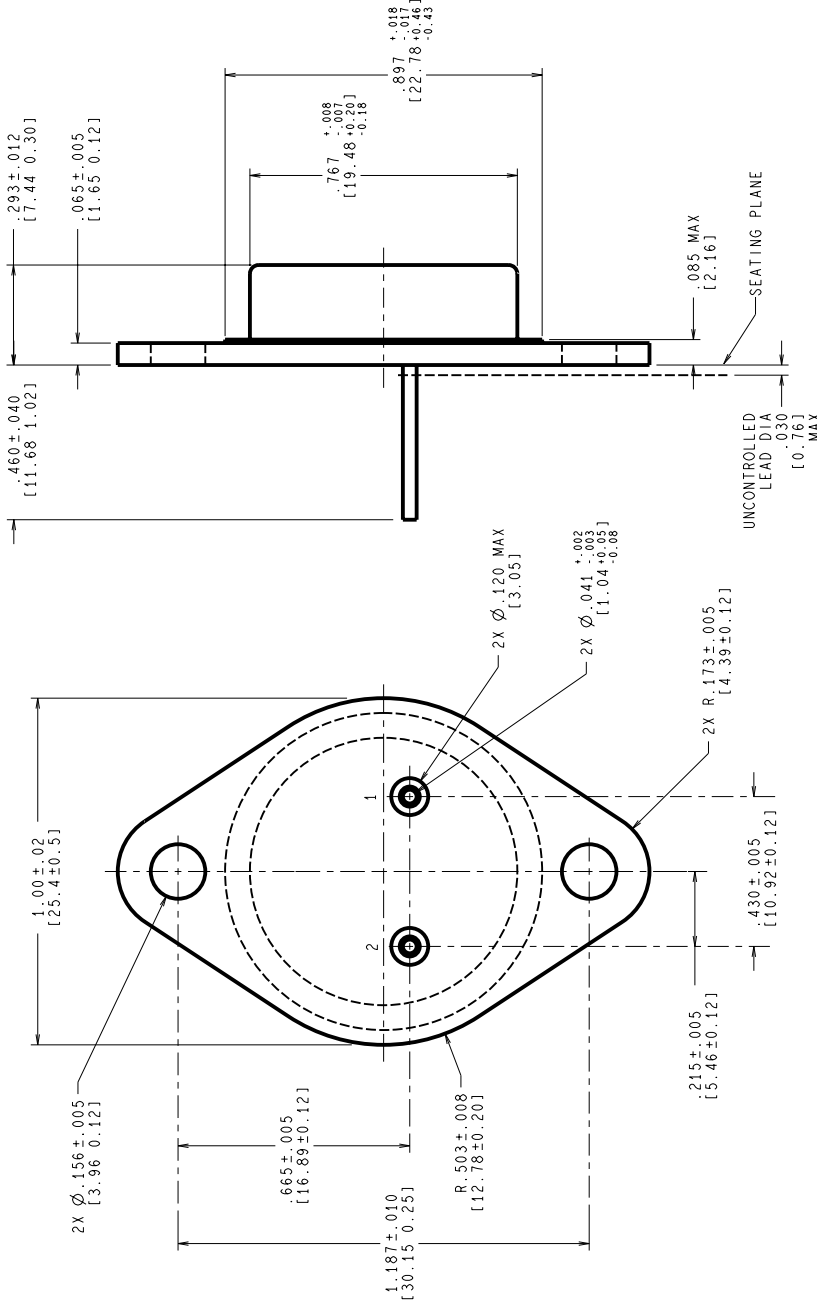



CONTROLLING DIMENSION IS INCH  
VALUES IN [ ] ARE MILLIMETERS

MIL-PRF-38535  
CONFIGURATION CONTROL

NOTES: UNLESS OTHERWISE SPECIFIED

1. STANDARD HEADER TYPE SOLID BASE.
2. STANDARD LEAD FINISH:  
PER MIL-PRF-38535 TYPE X OR EQUIVALENT.
3. LEAD NOT BENT GREATER THAN 15°.
4. DIMENSIONS BASED ON JEDEC STANDARD TO-3,  
PUBLICATION 95, PAGE 98.

APPROVALS	DATE	SCALE	SIZE	DRAWING NUMBER	REV
DRN: MARTA SUCHY	09/15/95	N/A	C	MKT-K02C	E
DWG. CHK.					
ENGR. CHK.					
PROJECTION 					
 <b>National Semiconductor</b> 2800 Semiconductor Dr., Santa Clara, CA 95052-8090					
<b>METAL CAN, TO-3, 2 LEAD, LOW PROFILE</b>					
DO NOT SCALE DRAWING SHEET 1 of 1					

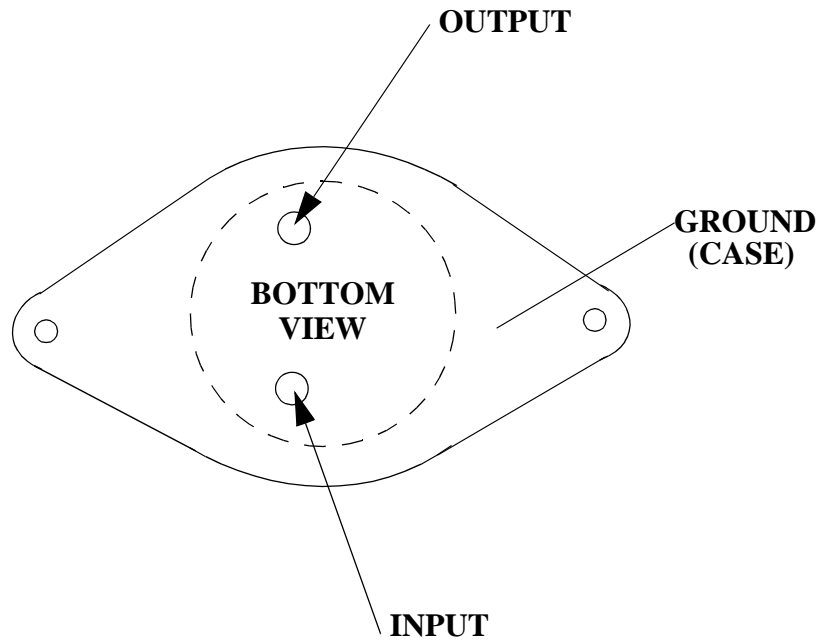

**LM2940K-XX/883**  
**2 - LEAD TO3**  
**CONNECTION DIAGRAM**  
**BOTTOM VIEW**  
**P000137A**



*National Semiconductor*  
MIL/AEROSPACE OPERATIONS  
2900 SEMICONDUCTOR DRIVE  
SANTA CLARA, CA 95050

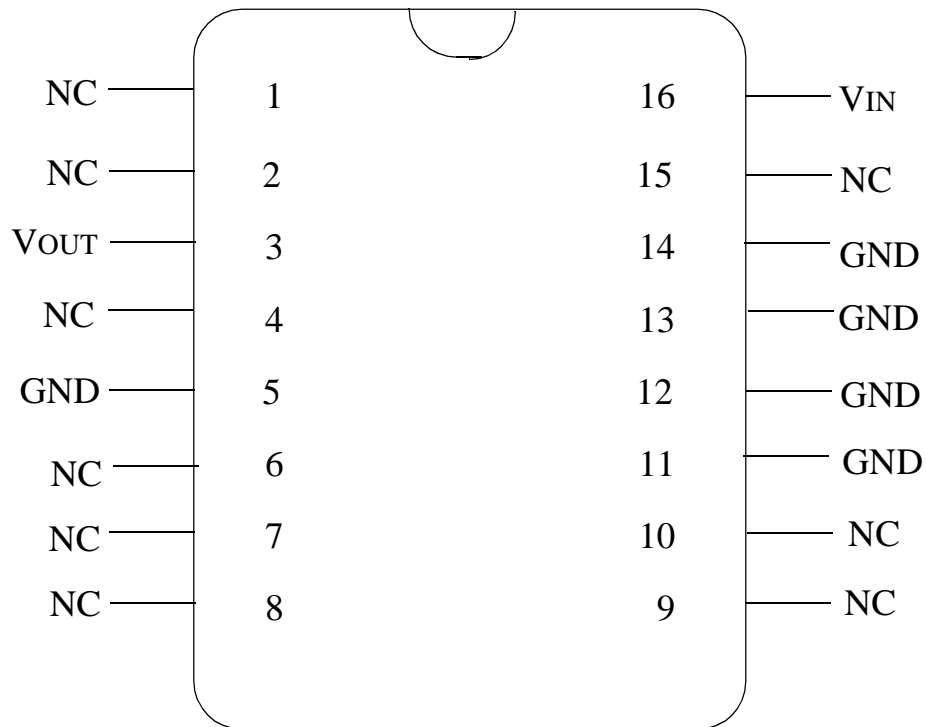

**LM2940J-XX**  
**16 - LEAD DIP**  
**CONNECTION DIAGRAM**  
**TOP VIEW**  
**P000159A**



National Semiconductor™

MIL/AEROSPACE OPERATIONS  
 2900 SEMICONDUCTOR DRIVE  
 SANTA CLARA, CA 95050

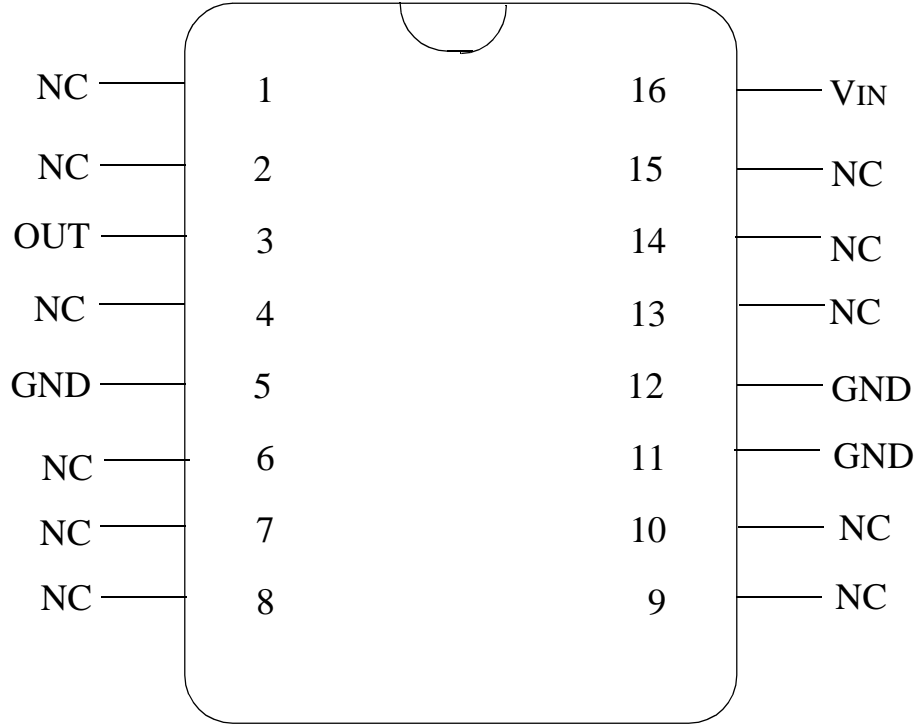

**LM2940WG**  
**16 - LEAD CERAMIC SOIC**  
**CONNECTION DIAGRAM**  
**TOP VIEW**  
**P000386A**



National Semiconductor™

MIL/AEROSPACE OPERATIONS  
2900 SEMICONDUCTOR DRIVE  
SANTA CLARA, CA 95050

REVISIONS			
LTR	DESCRIPTION	E.C.N.	DATE
A	RELEASE TO DOCUMENT CONTROL	11376	02/29/1996
B	LD PITCH TOL WAS ±.005; CHANGE LD RADIUS TO REF DIM; REMOVE THE OTHER R.006±.002; DIM. .040±.003 WAS .037±.003	11443	04/19/1996
C	R.015(0.38) WAS R.006(0.15)	11840	10/08/1997

APPROVALS	DATE	BY/APP'D
DRN: <i>MARYA SUCHY</i>	02/29/96	MS/KH
ENGR. CHK.		MS/KH
PROJECTION		
		
SCALE	SIZE	REV
N/A	C	C
DO NOT SCALE DRAWING		

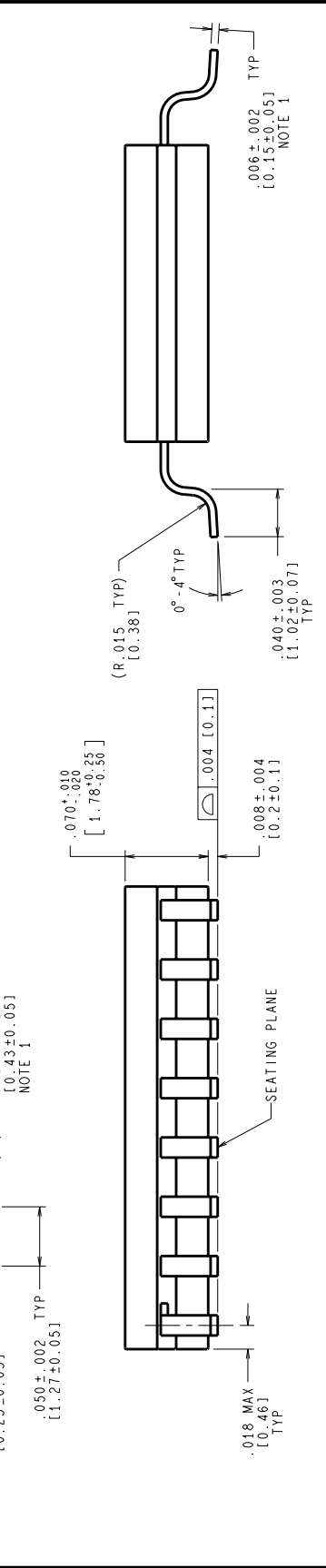
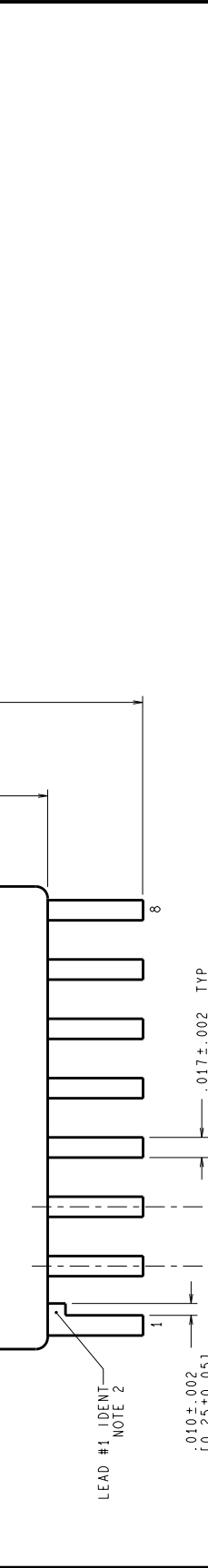
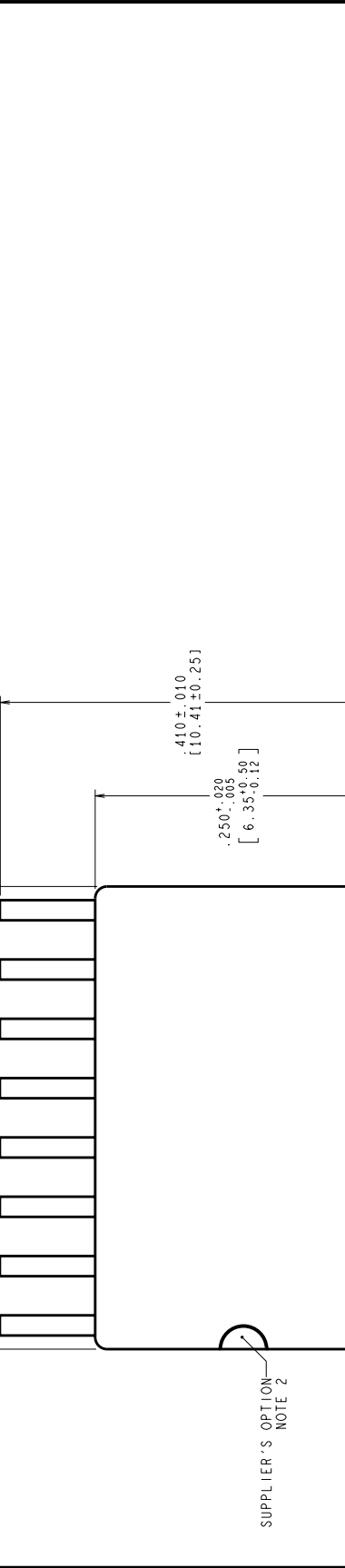

**MIL-PRF-38535  
CONFIGURATION CONTROL**

CONTROLLING DIMENSION IS INCH  
VALUES IN | ARE MILLIMETERS

- NOTES: UNLESS OTHERWISE SPECIFIED
- LEAD FINISH: SOLDER DIPPED WITH Sn60 OR Sn63 SOLDER CONFORMING TO MIL-PRF-38535 TO A MINIMUM THICKNESS OF 200 MICRONS / 5.08 MICROMETERS. SOLDER MAY BE APPLIED OVER LEAD BASIS METAL OR Sn PLATE. MAXIMUM LIMIT MAY BE INCREASED BY .003 IN / 0.08mm AFTER LEAD FINISH APPLIED.
  - LEAD 1 IDENTIFICATION SHALL BE:
    - A NOTCH OR OTHER MARK WITHIN THIS AREA
    - A TAB ON LEAD 1, EITHER SIDE
  - NO JEDEC REGISTRATION AS OF FEBRUARY 1996.

**National Semiconductor**  
2800 Semiconductor Dr., Santa Clara, CA 95052-8000

**CERPACK,  
16 LEAD,  
GULL WING**

SCALE: N/A C (SC) MKT-WG16A REV: C

DO NOT SCALE DRAWING SHEET 1 of 1

**Revision History**

Rev	ECN #	Rel Date	Originator	Changes
0A0	M0000589	10/08/99	Barbara Lopez	Initial Release of: MNL2940-15-X Rev. 0A0. Added note for power dissipation and reference to thermal resistance for Aluminum Nitride package.
1A1	M0003227	10/08/99	Rose Malone	Update MDS: MNL2940-15-X, Rev. 0A0 to MNL2940-15-X, Rev. 1A1. Moved reference to Controlling Document to Feature Section. Added Graphic's reference to WG Pkg to Main Table and Absolute Section and also Package Weight heading. Changed Vdo, Io = 100mA, Max. condition for subgroup 1 from 150mV to 200mV and subgroup 2 from 200mV to 300mV.