

# CLC425

## Ultra Low Noise Wideband Op Amp

### General Description

The CLC425 combines a wide bandwidth (**1.9GBW**) with a very low input noise ( $1.05\text{nV}/\sqrt{\text{Hz}}$ ,  $1.6\text{pA}/\sqrt{\text{Hz}}$ ) and low dc errors ( $100\mu\text{V } V_{OS}$ ,  $2\mu\text{V}/^\circ\text{C}$  drift) to provide a very precise, wide dynamic range op amp offering closed-loop gains of  $\geq 10$ .

Singularly suited for very wideband high gain operation, the CLC425 employs a traditional voltage feedback topology providing all the benefits of balanced inputs, such as low offsets and drifts, as well as a 96dB open loop gain, a 100dB CMRR and a 95dB PSRR.

The CLC425 also offers great flexibility with its externally adjustable supply current, allowing designers to easily choose the optimum set of power, bandwidth, noise and distortion performance. Operating from  $\pm 5\text{V}$  power supplies, the CLC425 defaults to a 15mA quiescent current, or by adding one external resistor, the supply current can be adjusted to less than 5mA.

The CLC425's combination of ultra low noise, wide gain bandwidth, high slew rate and low dc errors will enable applications in areas such as medical diagnostic ultrasound, magnetic tape & disk storage, communications and opto-electronics to achieve maximum high frequency signal-to-noise ratios.

### Enhanced Solutions (Military/Aerospace)

SMD Number: 5962-93259

Space level versions also available.

For more information, visit <http://www.national.com/mil>

### Features

- 1.9GHz gain-bandwidth product
- $1.05\text{nV}/\sqrt{\text{Hz}}$  input voltage noise

- $0.8\text{pA}/\sqrt{\text{Hz}}$  @  $I_{CC} \leq 5\text{mA}$
- $100\mu\text{V}$  input offset voltage,  $2\mu\text{V}/^\circ\text{C}$  drift
- $350\text{V}/\mu\text{s}$  slew rate
- 15mA to 5mA adjustable supply current
- Gain range  $\pm 10$  to  $\pm 1,000\text{V}/\text{V}$
- Evaluation boards & simulation macromodel
- $0.9\text{dB NF}$  @  $R_s = 700\Omega$

### Applications

- Instrumentation sense amplifiers
- Ultrasound pre-amps
- Magnetic tape & disk pre-amps
- Photo diode transimpedance amplifiers
- Wide band active filters
- Low noise figure RF amplifiers
- Professional audio systems
- Low noise loop filters for PLLs

### Equivalent Input Voltage Noise

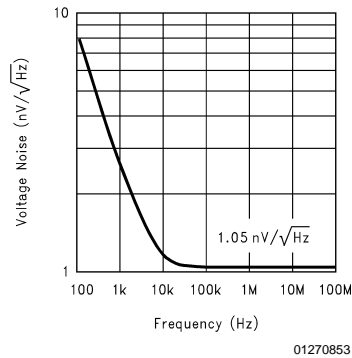

### Connection Diagrams

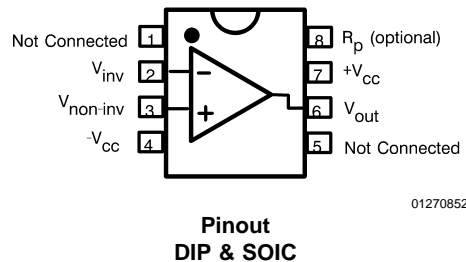
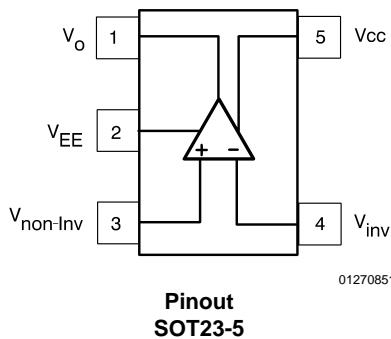

## Ordering Information

Package	Temperature Range Industrial	Part Number	Package Marking	NSC Drawing
8-pin plastic DIP	-40°C to +85°C	CLC425AJP	CLC425AJP	N08E
8-pin plastic SOIC	-40°C to +85°C	CLC425AJE	CLC425AJE	M08A
5-pin SOT	-40°C to +85°C	CLC425AJM5	A19	MA05A

**Absolute Maximum Ratings** (Note 1)

If Military/Aerospace specified devices are required, please contact the National Semiconductor Sales Office/Distributors for availability and specifications.

Supply Voltage ( $V_{CC}$ )	$\pm 7V$
$I_{OUT}$	
Output is short circuit protected to ground, but maximum reliability will be maintained if $I_{OUT}$ does not exceed...	125mA
Common Mode Input Voltage	$\pm V_{CC}$
Maximum Junction Temperature	+150°C
Operating Temperature Range	-40°C to +85°C

Storage Temperature Range	-65°C to +150°C
Lead Solder Duration (+300°C)	10 sec
ESD rating (human body model)	1000V

**Operation Ratings**

Thermal Resistance		
Package	( $\theta_{JC}$ )	( $\theta_{JA}$ )
MDIP	70°C/W	125°C/W
SOIC	65°C/W	145°C/W
SOT-23	115°C/W	185°C/W

**Electrical Characteristics**

$A_V = +20$ ,  $V_{CC} = \pm 5V$ ,  $R_g = 26.1\Omega$ ,  $R_L = 100\Omega$ ,  $R_f = 499\Omega$ ; unless specified

Symbol	Parameter	Conditions	Typ	Min/Max (Note 2)			Units
Ambient Temperature		CLC425AJ	+25°C	-40°C	+25°C	+85°	
<b>Frequency Domain Response</b>							
GBW	Gain Bandwidth Product	$V_{OUT} < 0.4V_{PP}$	1.9	1.5	1.5	1.0	GHz
SSBW	-3dB Bandwidth	$V_{OUT} < 0.4V_{PP}$	95	75	75	50	MHz
LSBW		$V_{OUT} < 5.0V_{PP}$	40	30	30	20	MHz
	Gain Flatness	$V_{OUT} < 0.4V_{PP}$					
GFP	Peaking	DC to 30MHz	0.3	0.7	0.5	0.7	dB
GFR	Rolloff	DC to 30MHz	0.1	0.7	0.5	0.7	dB
LPD	Linear Phase Deviation	DC to 30MHz	0.7	1.5	1.5	2.5	deg
<b>Time Domain Response</b>							
TRS	Rise and Fall Time	0.4V Step	3.7	4.7	4.7	7.0	ns
TSS	Settling Time to 0.2%	2V Step	22	30	30	40	ns
OS	Overshoot	0.4V Step	5	12	10	12	%
SR	SlewRate	2V Step	350	250	250	200	V/ $\mu$ s
<b>Distortion And Noise Response</b>							
HD2	2nd Harmonic Distortion	1V <sub>PP</sub> , 10MHz	-53	48	48	46	dBc
HD3	3rd Harmonic Distortion	1V <sub>PP</sub> , 10MHz	-75	65	65	60	dBc
IMD	3rd Order Intermodulation Intercept	10MHz	35				dBm
	Equivalent Input Noise						
VN	Voltage	1MHz to 100MHz	1.05	1.25	1.25	1.8	nV/ $\sqrt{Hz}$
ICN	Current	1MHz to 100MHz	1.6	4.0	2.5	2.5	pA/ $\sqrt{Hz}$
NF	Noise Figure	$R_s = 700\Omega$	0.9				dB
<b>Static, DC Performance</b>							
AOL	Open Loop Gain	DC	96	77	86	86	dB
VIO	Input Offset Voltage (Note 3)		$\pm 100$	$\pm 1000$	$\pm 800$	$\pm 1000$	$\mu$ V
DVIO	Average Drift		$\pm 2$	8	-	4	$\mu$ V/°C
IB	Input Bias Current (Note 3)	Non-Inverting	12	40	20	20	$\mu$ A
DIB	Average Drift		-100	-250	-	-120	nA/°C
IIO	Input Offset Current		$\pm 0.2$	3.4	2.0	2.0	$\mu$ A
DIIO	Average Drift		$\pm 3$	$\pm 50$	-	$\pm 25$	nA/C°
PSRR	Power Supply Rejection Ratio	DC	95	82	88	86	dB
CMRR	Common Mode Rejection Ratio	DC	100	88	92	90	dB
ICC	Supply Current (Note 3)	$R_L = \infty$	15	18	16	16	mA
<b>Miscellaneous Performance</b>							

**Electrical Characteristics** (Continued)
 $A_V = +20$ ,  $V_{CC} = \pm 5V$ ,  $R_g = 26.1\Omega$ ,  $R_L = 100\Omega$ ,  $R_f = 499\Omega$ ; unless specified

Symbol	Parameter	Conditions	Typ	Min/Max (Note 2)			Units
RINC	Input Resistance	Common-Mode	2	0.6	1.6	1.6	M $\Omega$
RIND		Differential-Mode	6	1	3	3	k $\Omega$
CINC	Input Capacitance	Common-Mode	1.5	2	2	2	pF
CIND		Differential-Mode	1.9	3	3	3	pF
ROUT	Output Resistance	Closed Loop	5	50	10	10	m $\Omega$
VO	Output Voltage Range	$R_L = \infty$	$\pm 3.8$	$\pm 3.5$	$\pm 3.7$	$\pm 3.7$	V
VOL		$R_L = 100\Omega$	$\pm 3.4$	$\pm 2.8$	$\pm 3.2$	$\pm 3.2$	V
CMIR	Input Voltage Range	Common Mode	$\pm 3.8$	$\pm 3.4$	$\pm 3.5$	$\pm 3.5$	V
IOP	Output Current	Source	80	70	70	70	mA
ION		Sink	90	45	55	55	mA

**Note 1:** "Absolute Maximum Ratings" are those values beyond which the safety of the device cannot be guaranteed. They are not meant to imply that the devices should be operated at these limits. The table of "Electrical Characteristics" specifies conditions of device operation.

**Note 2:** Max/min ratings are based on product characterization and simulation. Individual parameters are tested as noted. Outgoing quality levels are determined from tested parameters.

**Note 3:** AJ-level: spec. is 100% tested at +25°C, sample at 85°C.

# Typical Performance Characteristics

**Non-Inverting Frequency Response**

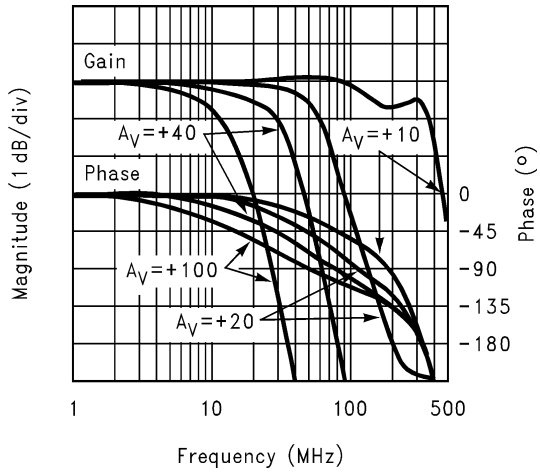

01270801

**Inverting Frequency Response**

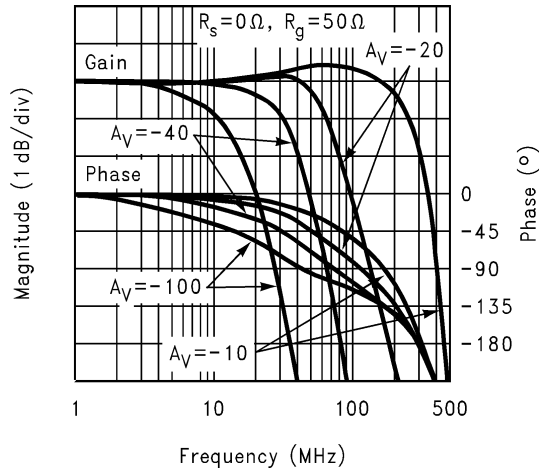

01270802

**Frequency Response vs.  $I_{CC}$  ( $A_V = +20$ )**

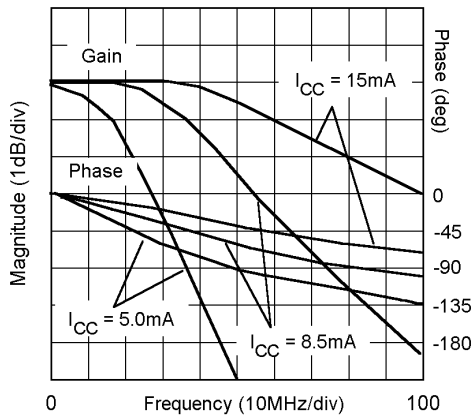

01270803

**Open Loop Gain and Phase vs.  $I_{CC}$**

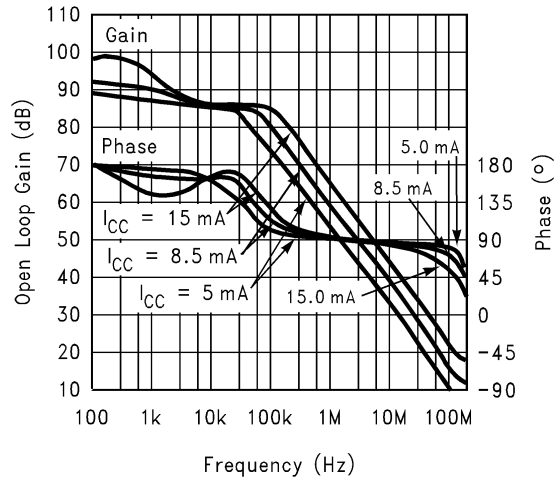

01270804

**Open Loop Gain and Phase vs.  $R_L$**

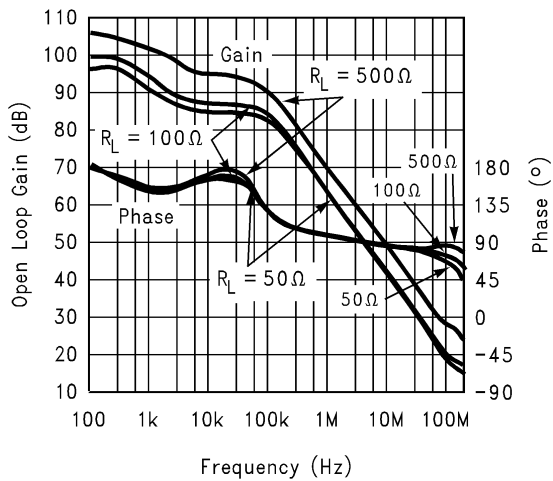

01270805

**Open Loop Gain and Phase vs. Temp**

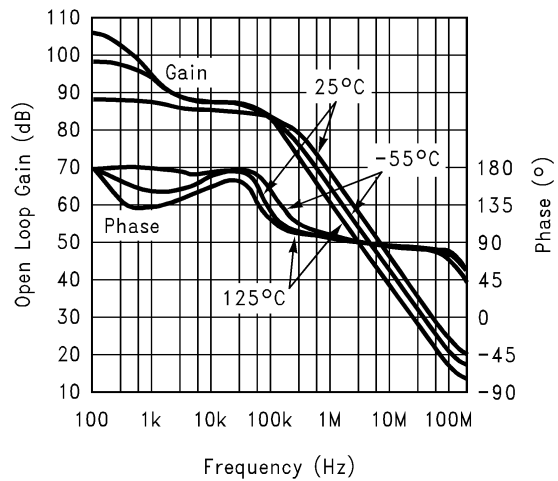

01270806

Typical Performance Characteristics (Continued)

Non-Inverting Response ( $I_{CC} = 5.0\text{mA}$ )

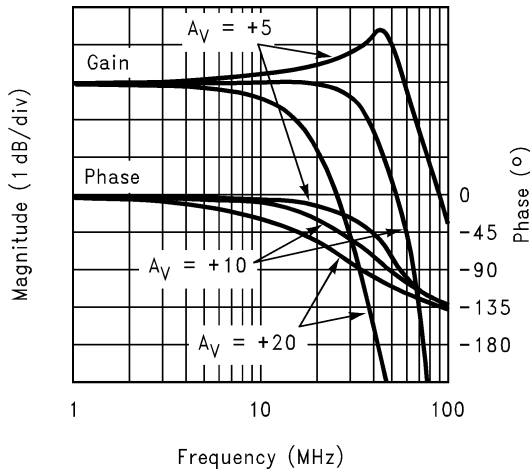

01270807

Frequency Response for Various  $R_L$ s

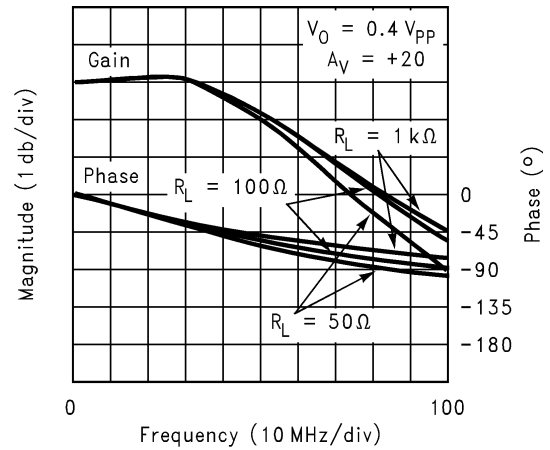

01270808

Gain Flatness & Linear Phase Deviation

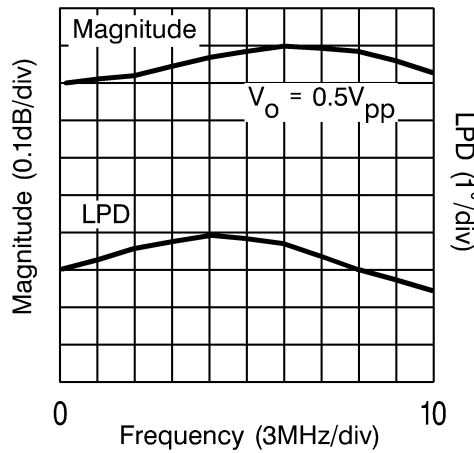

01270809

Equivalent Input Noise

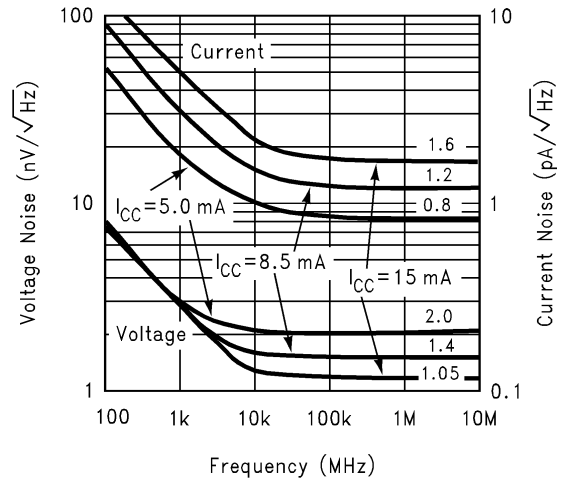

01270810

Maximum Output Swing vs. Frequency

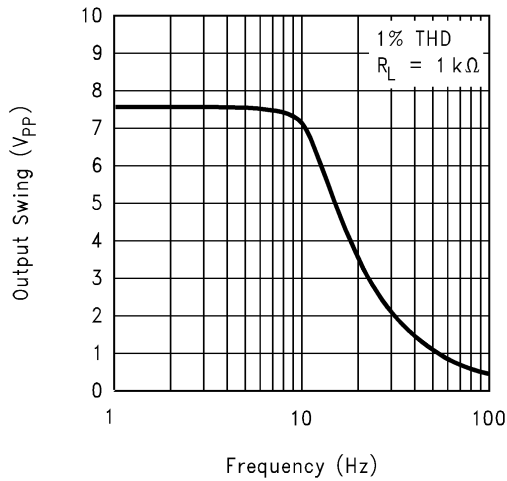

01270811

Closed-Loop Output Impedance

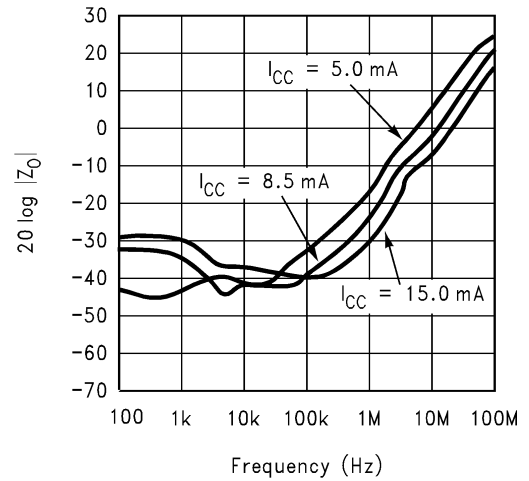

01270812

# Typical Performance Characteristics (Continued)

### CMRR vs. Common-Mode Input Voltage

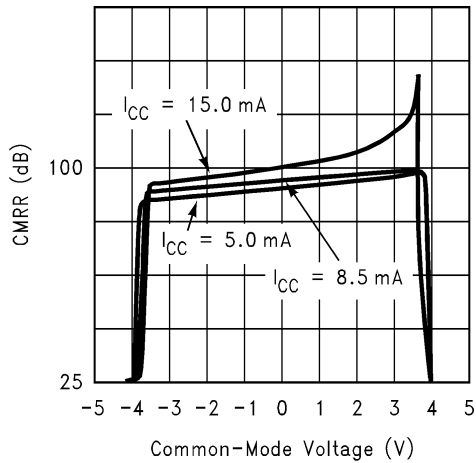

### Common-Mode Input Transimpedance

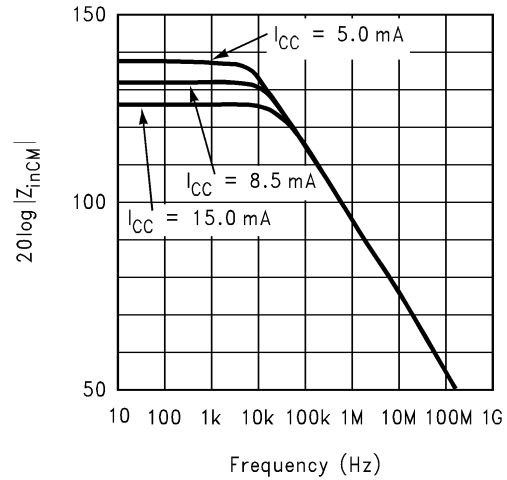

### Differential Input Impedance

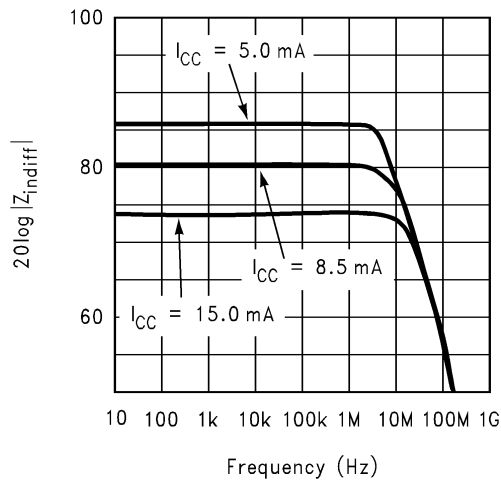

### Pulse Response ( $V_{O1} = V_{PP}$ )

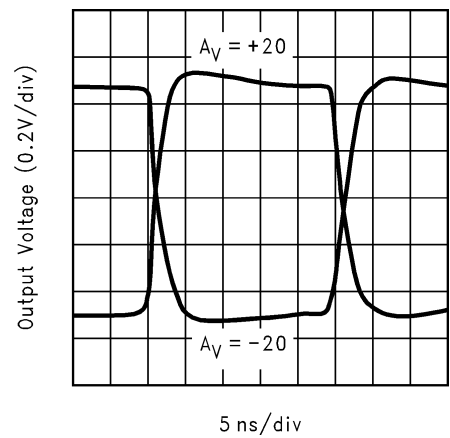

### Large Signal Pulse Response ( $V_{O1} = V_{PP}$ )

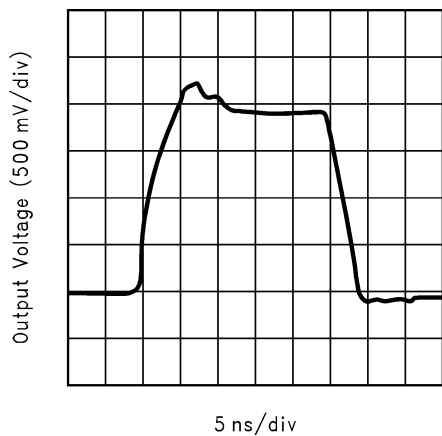

### Settling Time vs. Gain

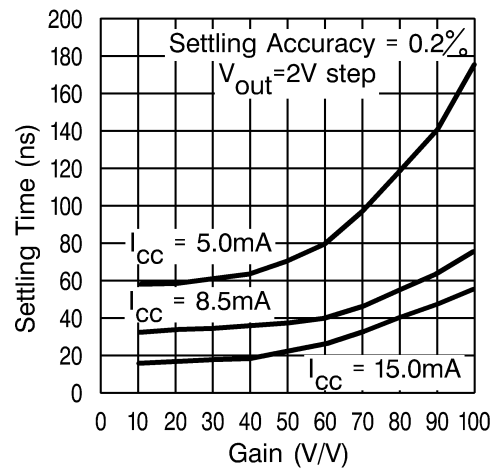

Typical Performance Characteristics (Continued)

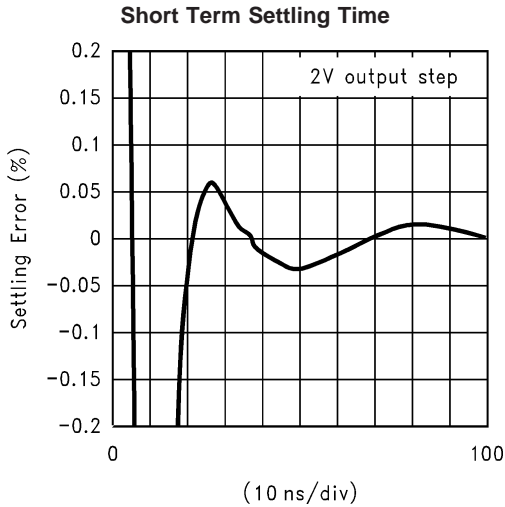

01270819

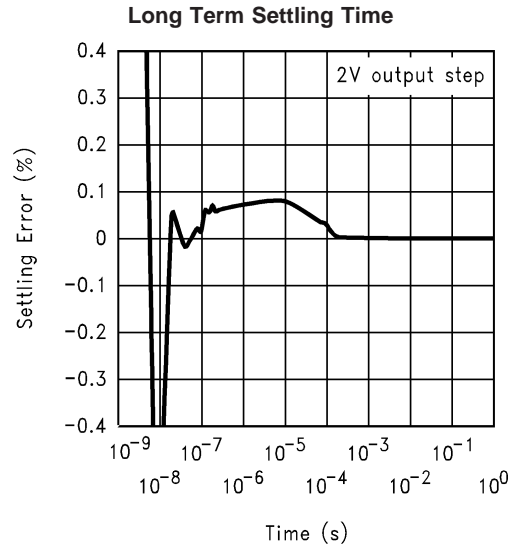

01270820

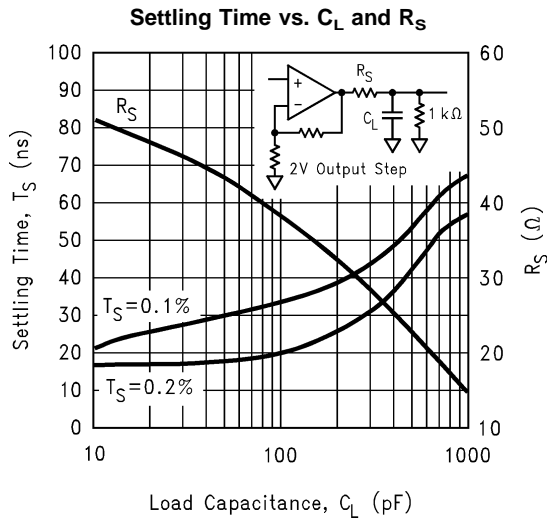

01270821

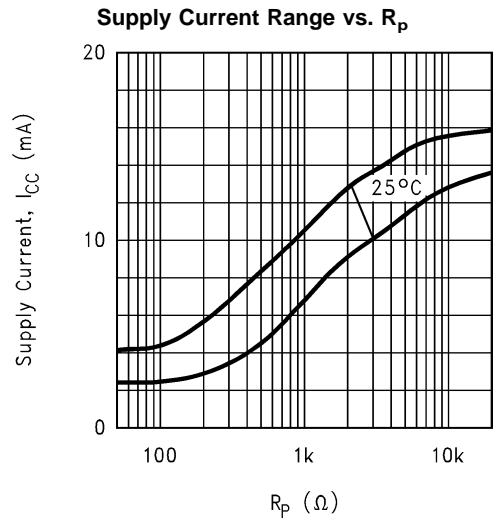

01270822

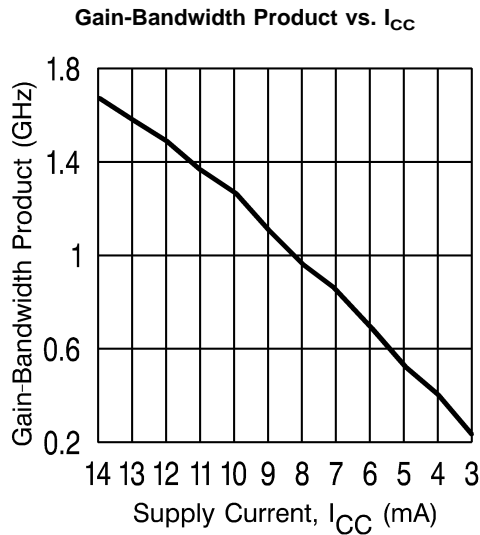

01270823

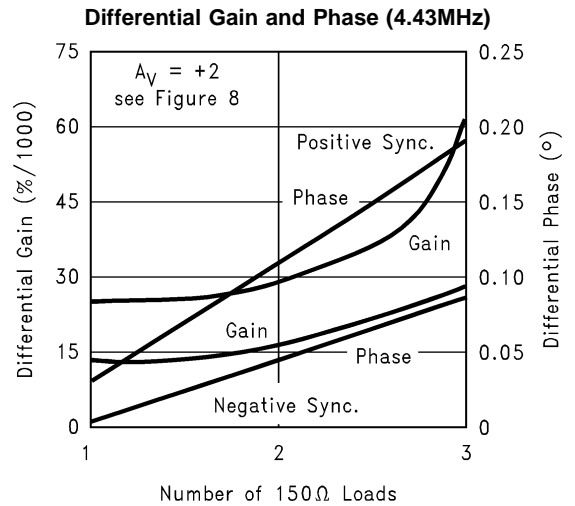

01270824

# Typical Performance Characteristics (Continued)

2nd and 3rd Harmonic Distortion ( $V_{O1} = V_{PP}$ )

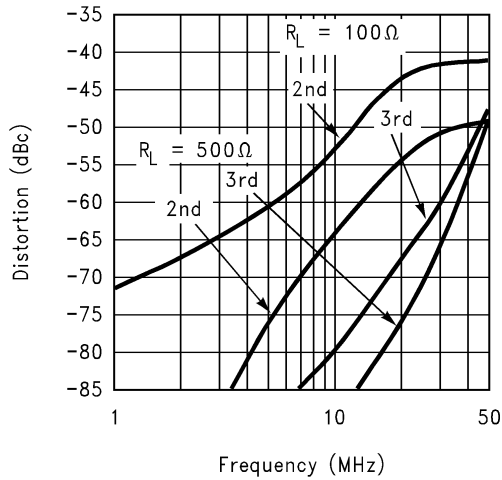

01270825

Distortion vs. Gain &  $I_{CC}$  ( $V_{O1} = V_{PP}$   $f_O = 3\text{MHz}$ )

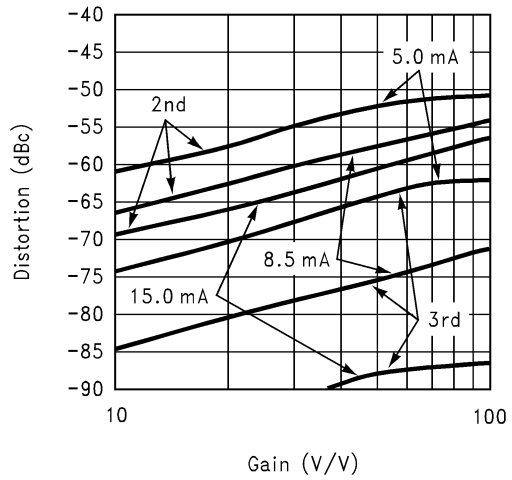

01270826

2-Tone, 3rd Order Intermodulation Intercept

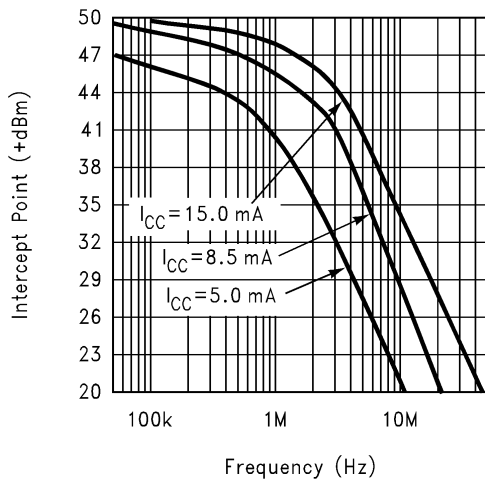

01270827

Output Voltage vs. Load

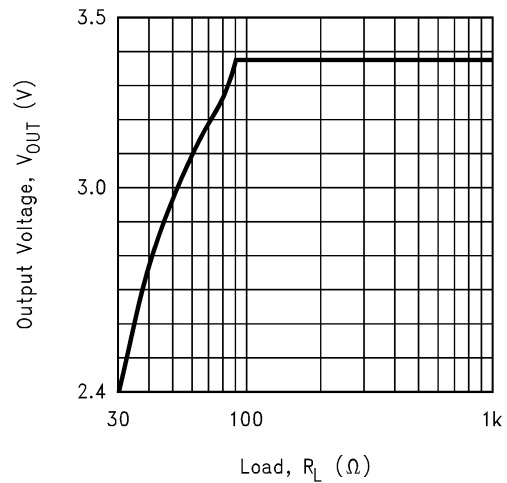

01270828

CMRR and PSRR

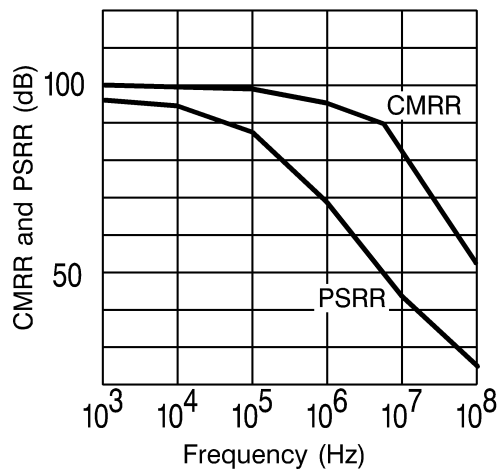

01270829

Typical DC Errors vs. Temperature

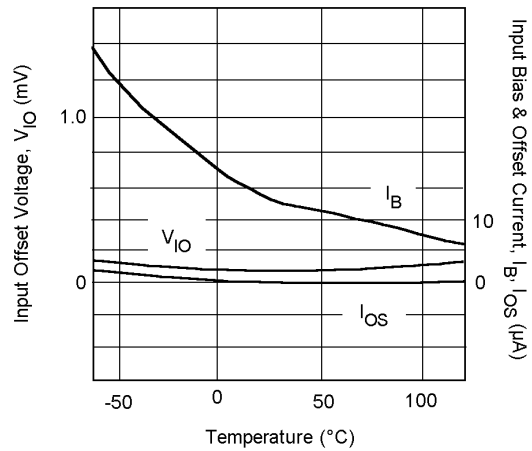

01270830

## Application Division

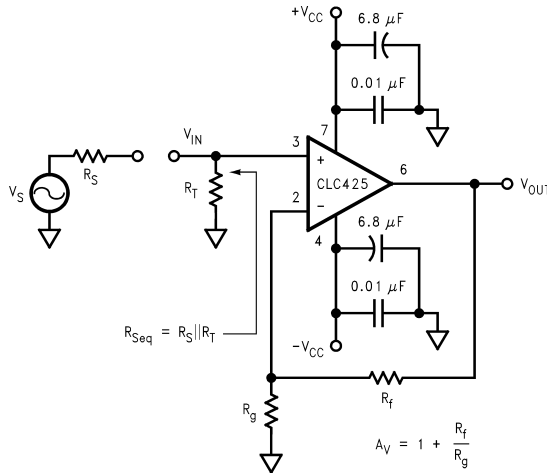

FIGURE 1. Non-Inverting Amplifier Configuration

### Introduction

The CLC425 is a very wide gain bandwidth, ultra low noise voltage feedback operational amplifier which enables application areas such as medical diagnostic ultrasound, magnetic tape & disk storage and fiber-optics to achieve maximum high frequency signal-to-noise ratios. The set of characteristic plots located in the “Typical Performance” section illustrates many of the performance trade offs. The following discussion will enable the proper selection of external components in order to achieve optimum device performance.

### Bias Current Cancellation

In order to cancel the bias current errors of the non-inverting configuration, the parallel combination of the gain setting ( $R_g$ ) and feedback ( $R_f$ ) resistors should equal the equivalent source resistance ( $R_{seq}$ ) as defined in Figure 1. Combining this constraint with the non-inverting gain equation also seen in Figure 1, allows both  $R_f$  and  $R_g$  to be determined explicitly from the following equations:

$$R_f = A_V R_{seq} \text{ and } R_g = R_f / (A_V - 1).$$

When driven from a  $0\Omega$  source, such as that from the output of an op amp, the non-inverting input of the CLC425 should be isolated with at least a  $25\Omega$  series resistor.

As seen in Figure 2, bias current cancellation is accomplished for the inverting configuration by placing a resistor ( $R_b$ ) on the non-inverting input equal in value to the resistance seen by the inverting input ( $R_f || (R_g + R_s)$ ).  $R_b$  is recommended to be no less than  $25\Omega$  for best CLC425 performance. The additional noise contribution of  $R_b$  can be minimized through the use of a shunt capacitor.

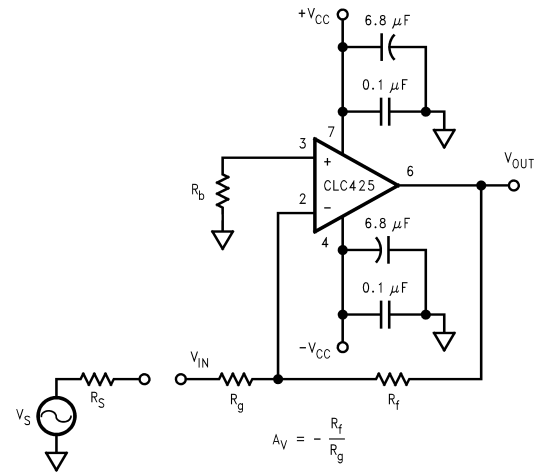

FIGURE 2. Inverting Amplifier Configuration

### Total Input Noise vs. Source Resistance

In order to determine maximum signal-to-noise ratios from the CLC425, an understanding of the interaction between the amplifier’s intrinsic noise sources and the noise arising from its external resistors is necessary.

describes the noise model for the non-inverting amplifier configuration showing all noise sources. In addition to the intrinsic input voltage noise ( $e_n$ ) and current noise ( $i_n = i_{n+} = i_{n-}$ ) sources, there also exists thermal voltage noise ( $e_t = \sqrt{4kTR}$ )

associated with each of the external resistors. Equation 1 provides the general form for total equivalent input voltage noise density ( $e_{ni}$ ). Equation 2 is a simplification of Equation 1 that assumes

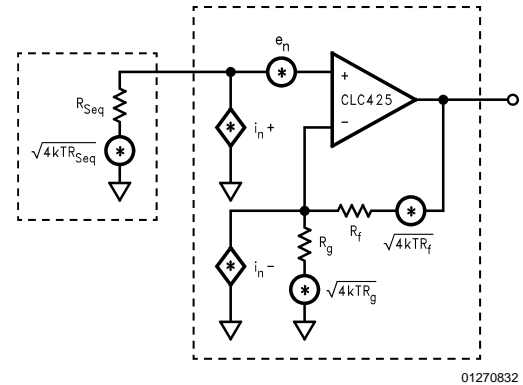
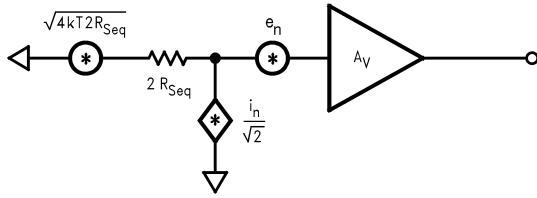

FIGURE 3. Non-inverting Amplifier Noise Model

$$e_{ni} = \sqrt{e_n^2 + (i_{n+} R_{seq})^2 + 4kTR_{seq} + (i_{n-} (R_f || R_g))^2 + 4kT(R_f || R_g)} \quad (1)$$

$R_f || R_g = R_{seq}$  for bias current cancellation. Figure 4 illustrates the equivalent noise model using this assumption. Figure 5 is a plot of  $e_{ni}$  against equivalent source resistance ( $R_{seq}$ ) with all of the contributing voltage noise source of Equation 2 shown. This plot gives the expected  $e_{ni}$  for a given ( $R_{seq}$ ) which assumes  $R_f || R_g = R_{seq}$  for bias current cancellation. The total equivalent output voltage noise ( $e_{no}$ ) is  $e_{ni} * A_V$ .

## Application Division (Continued)



01270835

FIGURE 4. Noise Model with  $R_f \parallel R_g = R_{seq}$ 

$$e_{ni} = \sqrt{e_n^2 + 2(i_n R_{seq})^2 + 4kT(2R_{seq})} \quad (2)$$

As seen in *Figure 5*,  $e_{ni}$  is dominated by the intrinsic voltage noise ( $e_n$ ) of the amplifier for equivalent source resistances below  $33.5\Omega$ . Between  $33.5\Omega$  and  $6.43k\Omega$ ,  $e_{ni}$  is dominated by the thermal noise ( $e_t = \sqrt{4kTR_{seq}}$ ) of the external resistor. Above  $6.43k\Omega$ ,  $e_{ni}$  is dominated by the amplifier's current noise ( $\sqrt{2i_n R_{seq}}$ ). The point at which the CLC425's voltage noise and current noise contribute equally occurs for  $R_{seq} = 464\Omega$  (i.e.,  $e_n / \sqrt{4kT} = 2i_n$ ). As an example, configured with a gain of  $+20V/V$  giving a  $-3dB$  of  $90MHz$  and driven from an  $R_{seq} = 25\Omega$ , the CLC425 produces a total equivalent input noise voltage ( $e_{ni} \times \sqrt{Hz} = 1.57 \times 90MHz$ ) of  $16.5\mu V_{rms}$ .

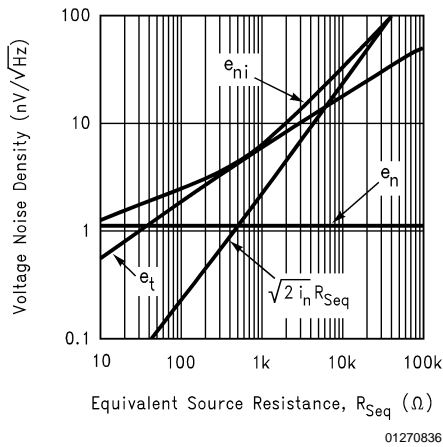

01270836

FIGURE 5. Voltage Noise Density vs. Source Resistance

If bias current cancellation is not a requirement, then  $R_f \parallel R_g$  does not need to equal  $R_{seq}$ . In this case, according to Equation 1,  $R_f R_g$  should be as low as possible in order to minimize noise. Results similar to Equation 1 are obtained for the inverting configuration of *Figure 2* if  $R_{seq}$  is replaced by  $R_b$  and  $R_g$  is replaced by  $R_g + R_s$ . With these substitutions, Equation 1 will yield an  $e_{ni}$  referred to the non-inverting input. Referring  $e_{ni}$  to the inverting input is easily accomplished by multiplying  $e_{ni}$  by the ratio of non-inverting to inverting gains.

**Noise Figure**

Noise Figure (NF) is a measure of the noise degradation caused by an amplifier.

$$NF = 10 \log \left\{ \frac{S_i / N_i}{S_o / N_o} \right\} = 10 \log \left\{ \frac{e_{ni}^2}{e_t^2} \right\} \quad (3)$$

The Noise Figure formula is shown in Equation 3. The addition of a terminating resistor  $R_T$ , reduces the external thermal noise but increases the resulting NF. The NF is increased because  $R_T$  reduces the input signal amplitude thus reducing the input SNR.

$$NF = 10 \log \left( \frac{e_n^2 + i_n^2 (R_{seq} + (R_f \parallel R_g)^2) + 4kTR_{seq} + 4kT(R_f \parallel R_g)}{4kTR_{seq}} \right) \quad (4)$$

The noise figure is related to the equivalent source resistance ( $R_{seq}$ ) and the parallel combination of  $R_f$  and  $R_g$ . To minimize noise figure, the following steps are recommended:

- Minimize  $R_f \parallel R_g$
- Choose the Optimum  $R_S$  ( $R_{OPT}$ )

$R_{OPT}$  is the point at which the NF curve reaches a minimum and is approximated by:

$$R_{OPT} \approx e_n / i_n$$

*Figure 6* is a plot of NF vs  $R_s$  with  $R_f R_g = 9.09$  ( $A_v = +10$ ). The NF curves for both Unterminated and Terminated systems are shown. The Terminated curve assumes  $R_s = R_T$ . The table indicates the NF for various source resistances including  $R_s = R_{OPT}$ .

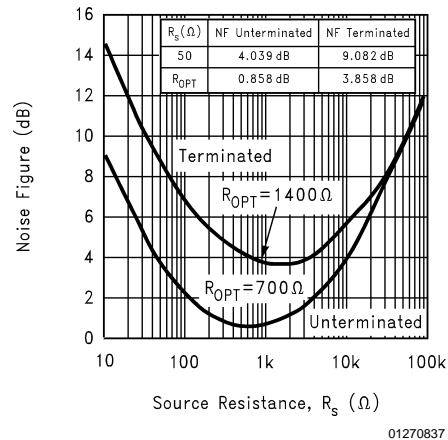

01270837

FIGURE 6. Noise Figure vs. Source Resistance

**Supply Current Adjustment**

The CLC425's supply current can be externally adjusted downward from its nominal value by adding an optional resistor ( $R_p$ ) between pin 8 and the negative supply as shown in *Figure 7*. Several of the plots found within the plot pages demonstrate the CLC425's behavior at different supply currents. The plot labeled " $I_{cc}$  vs  $R_p$ " provides the means for selecting  $R_p$  and shows the results of standard IC process variation which is bounded by the  $25^\circ C$  curve.

## Application Division (Continued)

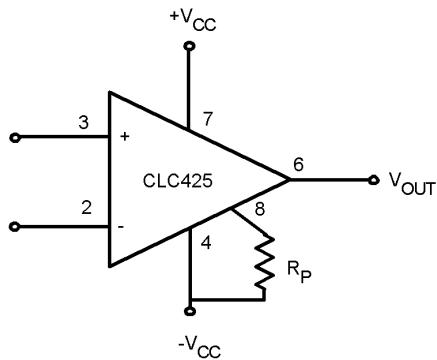

01270838

**FIGURE 7. External Supply Current Adjustment**

### Non-Inverting Gains Less Than 10V/V

Using the CLC425 at lower non-inverting gains requires external compensation such as the shunt compensation as shown in *Figure 8*. The quiescent supply current must also be reduced to 5mA with  $R_p$  for stability. The compensation capacitors are chosen to reduce frequency response peaking to less than 1dB. The plot in the "Typical Performance" section labeled "differential gain and Phase" shows the video performance of the CLC425 with this compensation circuitry.

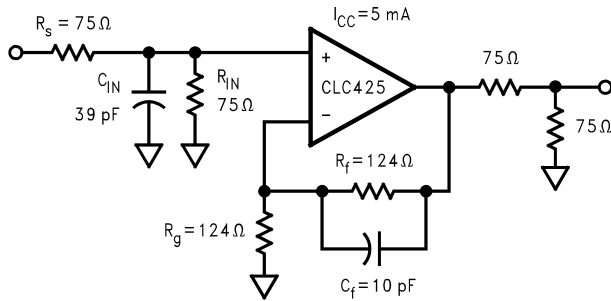

01270839

**FIGURE 8. External Shunt Compensation**

### Inverting Gains Less Than 10V/V

The lag compensation of *Figure 9* will achieve stability for lower gains. Placing the network between the two input terminals does not affect the closed-loop nor noise gain, but is best used for the inverting configuration because of its affect on the non-inverting input impedance.

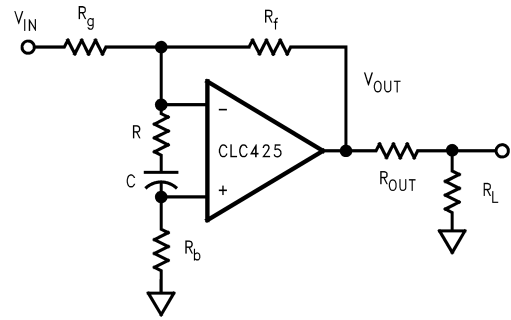

01270841

**FIGURE 9. External Lag Compensation**

### Single-Supply Operation

The CLC425 can be operated with single power supply as shown in *Figure 10*. Both the input and output are capacitively coupled to set the dc operating point.

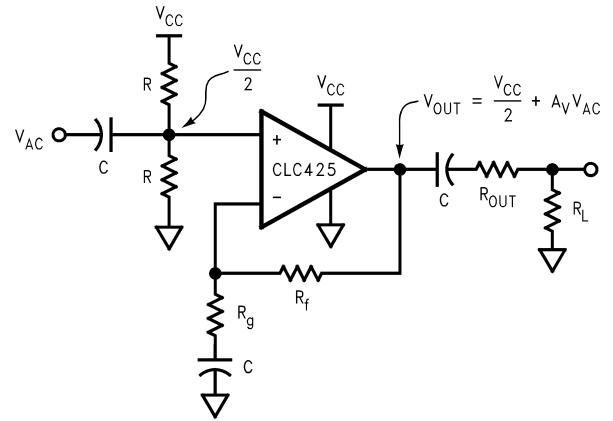

01270843

**FIGURE 10. Single Supply Operation**

### Low Noise Transimpedance Amplifier

The circuit of *Figure 11* implements a low-noise transimpedance amplifier commonly used with photo-diodes. The transimpedance gain is set by  $R_f$ . The simulated frequency response is shown in *Figure 12* and shows the influence  $C_f$  has over gain flatness. Equation 4 provides the total input current noise density ( $i_{ni}$ ) equation for the basic transimpedance configuration and is plotted against feedback resistance ( $R_f$ ) showing all contributing noise sources in *Figure 13*. This plot indicates the expected total equivalent input current noise density ( $i_{ni}$ ) for a given feedback resistance ( $R_f$ ). The total equivalent output voltage noise density ( $e_{no}$ ) is  $i_{ni} * R_f$ .

Application Division (Continued)

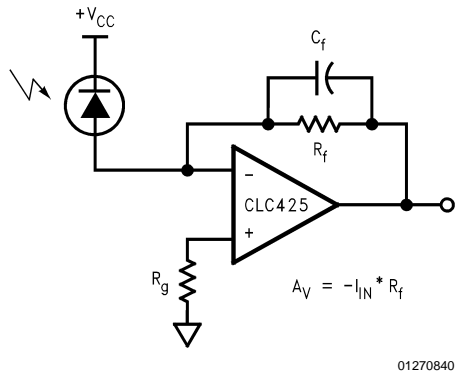

01270840

FIGURE 11. Transimpedance Amplifier Configuration

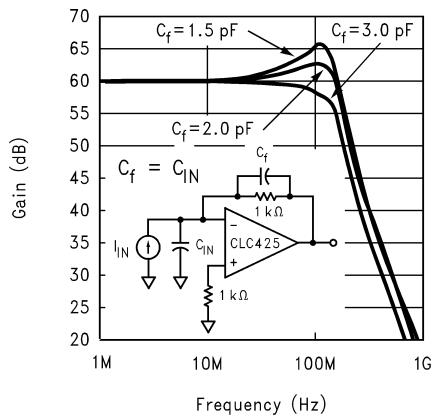

01270842

FIGURE 12. Transimpedance Amplifier Frequency Response

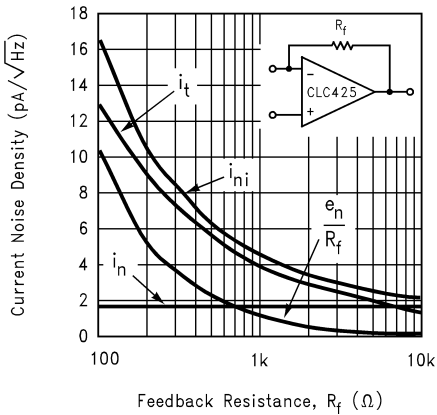

01270844

FIGURE 13. Current Noise Density vs. Feedback Resistance

$$i_{ni} = \sqrt{i_n^2 + \left(\frac{e_n}{R_f}\right)^2 + \frac{4kT}{R_f}} \quad (5)$$

Very Low Figure Amplifier

The circuit of Figure 14 implements a very low Noise Figure amplifier using a step-up transformer combined with a CLC425 and a CLC404. The circuit is configured with a gain of 35.6dB. The circuit achieves measured Noise Figures of less than 2.5dB in the 10-40MHz region, 3<sup>rd</sup> order intercepts exceed +30dB for frequencies less than 40MHz and gain flatness of 0.5dB is measured in the 1-50MHz passbands. Application Note OA-14 provides greater detail on these low Noise Figure techniques.

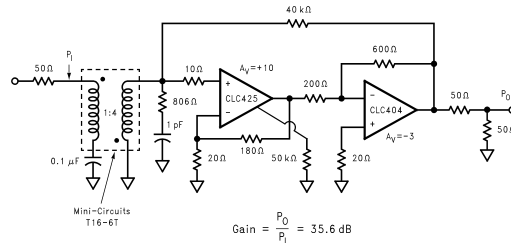

01270846

FIGURE 14. Very Noise Figure Amplifier

Low Noise Integrator

The CLC425 implements a deBoo integrator shown in Figure 15. Integration linearity is maintained through positive feedback. The CLC425's low input offset voltage and matched inputs allowing bias current cancellation provide for very precise integration. Stability is maintained through the constraint on the circuit elements.

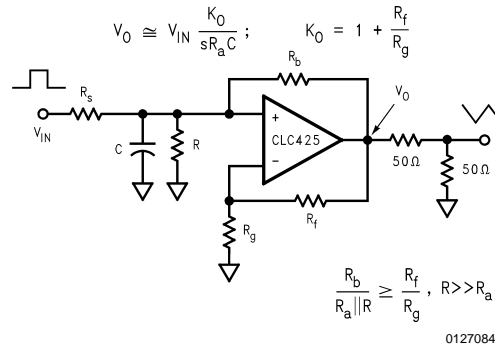

01270848

FIGURE 15. Low Noise Integrator

High-Gain Sallen-Key Active Filters

The CLC425 is well suited for high gain Sallen-Key type of active filters. Figure 16 shows the 2<sup>nd</sup> order Sallen-Key low pass filter topology. Using component predistortion methods as discussed in OA-21 enables the proper selection of components for these high-frequency filters.

## Application Division (Continued)

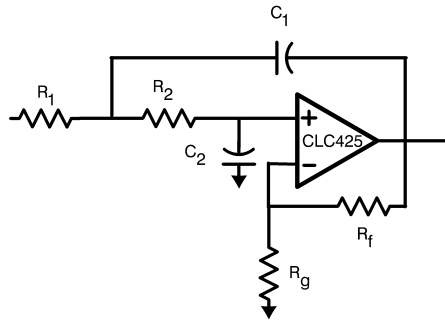

01270856

**FIGURE 16. Sallen-Key Active Filter Topology**

### Low Noise Magnetic Media Equalizer

The CLC425 implements a high-performance low noise equalizer for such applications as magnetic tape channels as shown in *Figure 17*. The circuit combines an integrator with a bandpass filter to produce the low noise equalization. The circuit's simulated frequency response is illustrated in *Figure 18*.

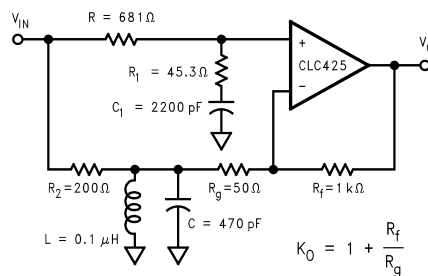

01270847

$$\frac{V_O}{V_{IN}} = K_0 \left( \frac{sC_1 R_1 + 1}{sC_1 (R_1 + R) + 1} - \left( \frac{R_f}{R_f + R_g} \right) \frac{sLR_g}{s^2 LCR_2 R_g + sL(R_2 + R_g) + R_2 R_g} \right)$$

**FIGURE 17. Low Noise Magnetic Media Equalizer**

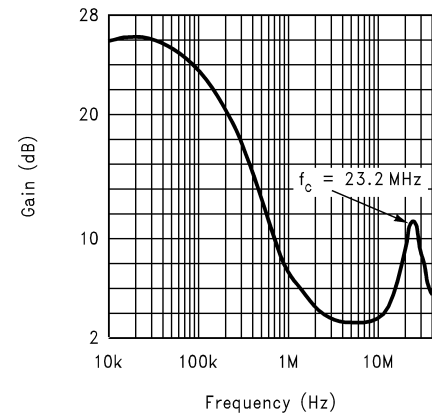

01270849

**FIGURE 18. Equalizer Frequency Response**

### Low-Noise Phase-Locked Loop Filter

The CLC425 is extremely useful as a Phase-Locked Loop filter in such applications as frequency synthesizers and data synchronizers. The circuit of *Figure 19* implements one possible PLL filter with the CLC425.

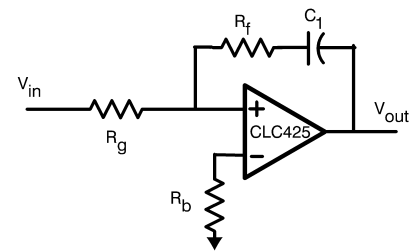

01270857

**FIGURE 19. Phase-Locked Loop Filter**

### Decreasing the Input Noise Voltage

The input noise voltage of the CLC425 can be reduced from its already low  $1.05\text{nV}/\sqrt{\text{Hz}}$  by slightly increasing the supply current. Using a  $50\text{k}\Omega$  resistor to ground on pin 8, as shown in the circuit of *Figure 14*, will increase the quiescent current to  $\approx 17\text{mA}$  and reduce the input noise voltage to  $< 0.95\text{nV}/\sqrt{\text{Hz}}$ .

### Printed Circuit Board Layout

Generally, a good high-frequency layout will keep power supply and ground traces away from the inverting input and output pins. Parasitic capacitances on these nodes to ground will cause frequency response peaking and possible circuit oscillation, see OA-15 for more information. National suggests the CLC730013-DIP, CLC730027-SOIC, or CLC730068-SOT evaluation board as a guide for high frequency layout and as an aid in device testing and characterization.

**Physical Dimensions** inches (millimeters)

unless otherwise noted

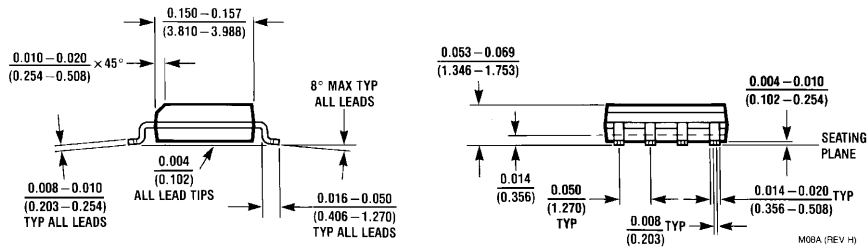
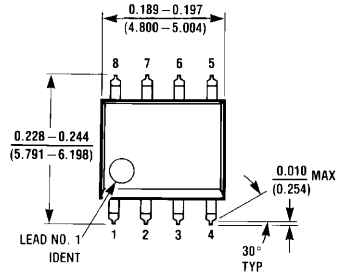

**8-Pin SOIC**  
NS Package Number M08A

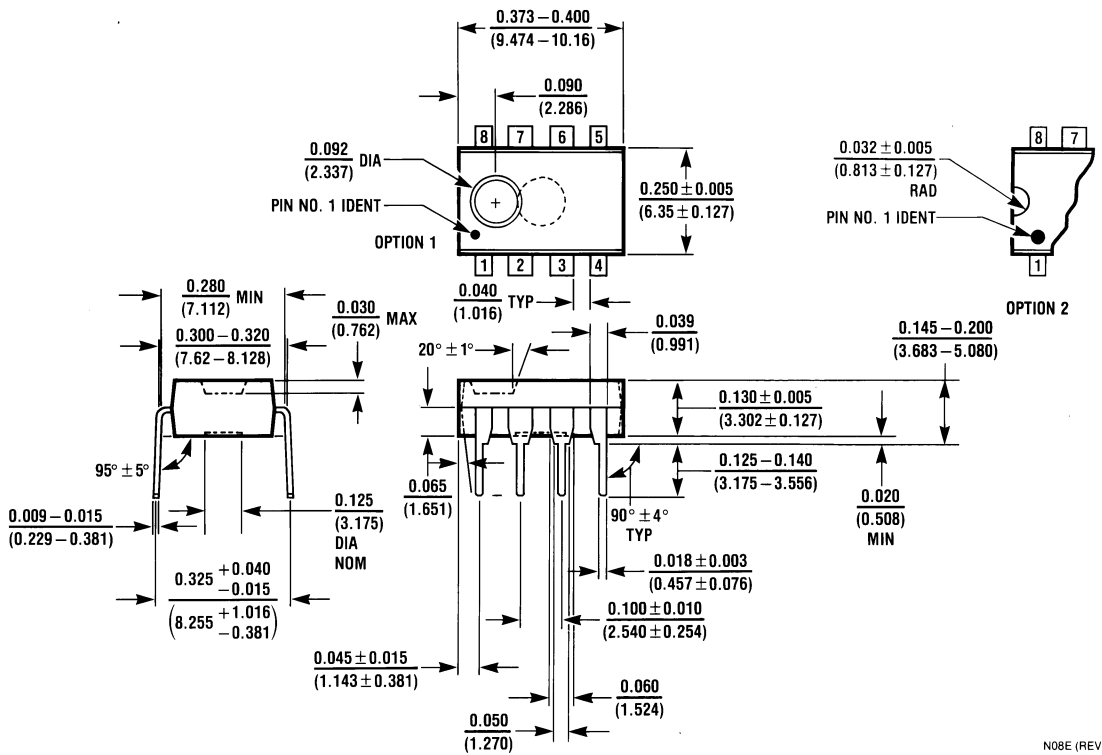

**8-Pin MDIP**  
NS Package Number N08E

**Physical Dimensions** inches (millimeters) unless otherwise noted (Continued)

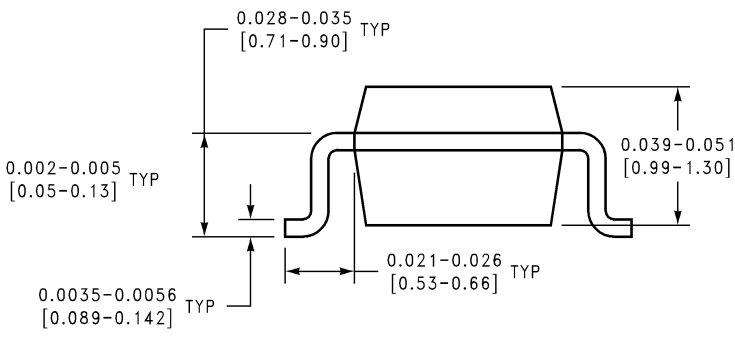
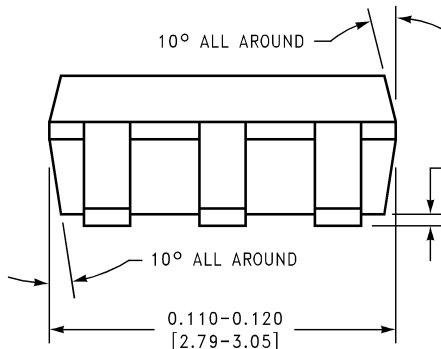
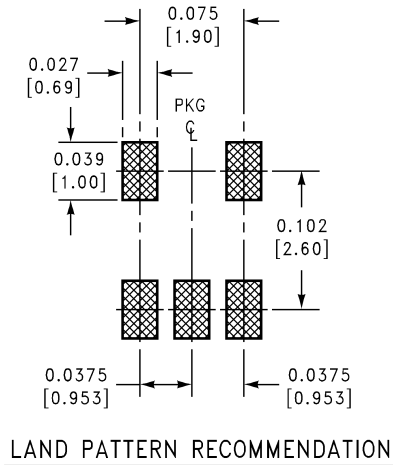
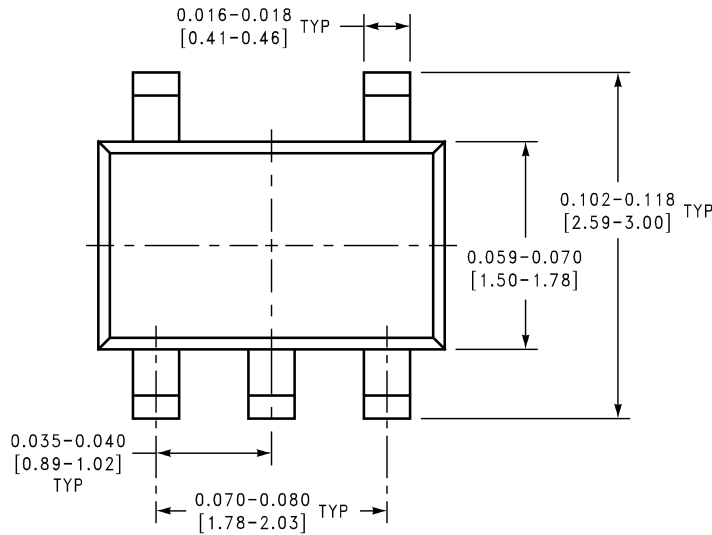

**5-Pin SOT23  
NS Package Number MA05A**

MA05A (REV D)

**LIFE SUPPORT POLICY**

NATIONAL'S PRODUCTS ARE NOT AUTHORIZED FOR USE AS CRITICAL COMPONENTS IN LIFE SUPPORT DEVICES OR SYSTEMS WITHOUT THE EXPRESS WRITTEN APPROVAL OF THE PRESIDENT AND GENERAL COUNSEL OF NATIONAL SEMICONDUCTOR CORPORATION. As used herein:

1. Life support devices or systems are devices or systems which, (a) are intended for surgical implant into the body, or (b) support or sustain life, and whose failure to perform when properly used in accordance with instructions for use provided in the labeling, can be reasonably expected to result in a significant injury to the user.
2. A critical component is any component of a life support device or system whose failure to perform can be reasonably expected to cause the failure of the life support device or system, or to affect its safety or effectiveness.

 <p><b>National Semiconductor Corporation</b> Americas Email: support@nsc.com</p> <p>www.national.com</p>	<p><b>National Semiconductor Europe</b></p> <p>Fax: +49 (0) 180-530 85 86 Email: europe.support@nsc.com</p> <p>Deutsch Tel: +49 (0) 69 9508 6208 English Tel: +44 (0) 870 24 0 2171 Français Tel: +33 (0) 1 41 91 8790</p>	<p><b>National Semiconductor Asia Pacific Customer Response Group</b></p> <p>Tel: 65-2544466 Fax: 65-2504466 Email: ap.support@nsc.com</p>	<p><b>National Semiconductor Japan Ltd.</b></p> <p>Tel: 81-3-5639-7560 Fax: 81-3-5639-7507</p>
--	--	--	--