

LM124A/LM124JAN

Low Power Quad Operational Amplifiers

General Description

The LM124/124A consists of four independent, high gain, internally frequency compensated operational amplifiers which were designed specifically to operate from a single power supply over a wide range of voltages. Operation from split power supplies is also possible and the low power supply current drain is independent of the magnitude of the power supply voltage.

Application areas include transducer amplifiers, DC gain blocks and all the conventional op amp circuits which now can be more easily implemented in single power supply systems. For example, the LM124/124A can be directly operated off of the standard +5Vdc power supply voltage which is used in digital systems and will easily provide the required interface electronics without requiring the additional +15Vdc power supplies.

Unique Characteristics

- In the linear mode the input common-mode voltage range includes ground and the output voltage can also swing to ground, even though operated from only a single power supply voltage
- The unity gain cross frequency is temperature compensated
- The input bias current is also temperature compensated

Advantages

- Eliminates need for dual supplies
- Four internally compensated op amps in a single package
- Allows directly sensing near GND and V_{OUT} also goes to GND
- Compatible with all forms of logic
- Power drain suitable for battery operation

Features

- Internally frequency compensated for unity gain
- Large DC voltage gain 100 dB
- Wide bandwidth (unity gain) 1 MHz (temperature compensated)
- Wide power supply range:
Single supply 3V to 32V
or dual supplies $\pm 1.5V$ to $\pm 16V$
- Very low supply current drain (700 μA)—essentially independent of supply voltage
- Low input biasing current 45 nA (temperature compensated)
- Low input offset voltage 2 mV and offset current: 5 nA
- Input common-mode voltage range includes ground
- Differential input voltage range equal to the power supply voltage
- Large output voltage swing 0V to $V^+ - 1.5V$

Ordering Information

NSC Part Number	JAN Part Number	NSC Package Number	Package Description
JL124BCA	JM38510/11005BCA	J14A	14LD CERDIP
JL124BDA	JM38510/11005BDA	W14B	14LD CERPACK
JL124BZA	JM38510/11005BZA	WG14A	14LD Ceramic SOIC
JL124SCA	JM38510/11005SCA	J14A	14LD CERDIP
JL124SDA	JM38510/11005SDA	W14B	14LD CERPACK
JL124ABCA	JM38510/11006BCA	J14A	14LD CERDIP
JL124ABDA	JM38510/11006BDA	W14B	14LD CERPACK
JL124ABZA	JM38510/11006BZA	WG14A	14LD Ceramic SOIC
JL124ASCA	JM38510/11006SCA	J14A	14LD CERDIP
JL124ASDA	JM38510/11006SDA	W14B	14LD CERPACK
JL124ASZA	JM38510/11006SZA	WG14A	14LD Ceramic SOIC

Connection Diagrams

Dual-In-Line Package

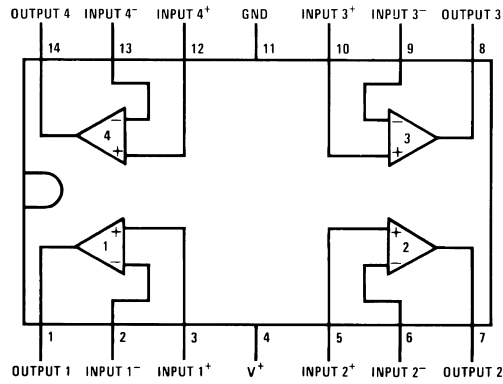

20100701

Top View

See NS Package Number J14A

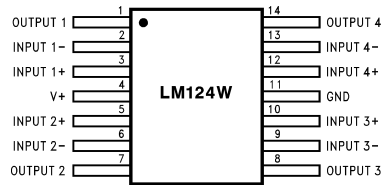

20100733

See NS Package Number W14B or WG14A

Schematic Diagram (Each Amplifier)

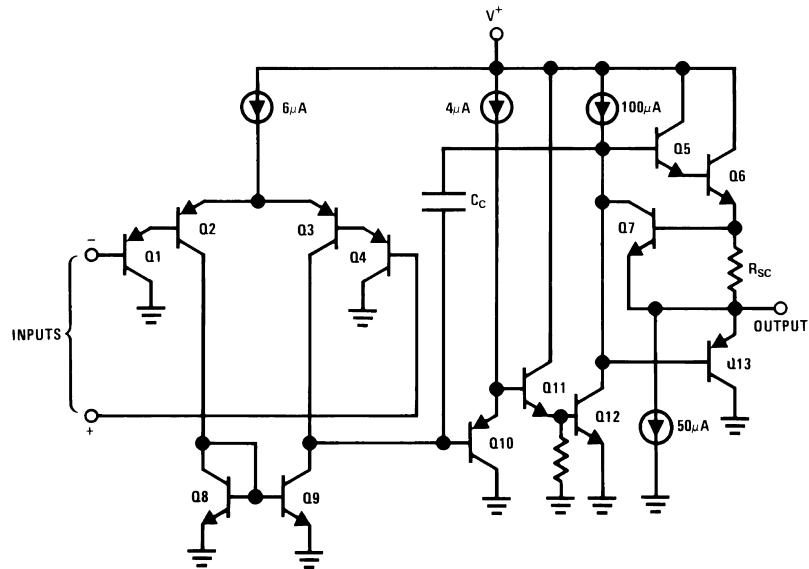

20100702

Absolute Maximum Ratings (Note 1)

Power Dissipation (Note 2)	
CERDIP	400mW
CERPACK	350mW
Ceramic SOIC	350mW
Supply Voltage, V ⁺	36V _{DC} or +18V _{DC}
Input Voltage Differential	30V _{DC}
Input Voltage	-0.3V _{DC} to +32V _{DC}
Input Current (V _{IN} < -0.3V _{DC}) (Note 3)	10 to 0.1mA
Output Short-Circuit to GND (Note 4)	
V ⁺ ≤ 15V _{DC} and T _A = 25°C (One Amplifier)	Continuous
Operating Temperature Range	-55°C ≤ T _A ≤ +125°C
Maximum Junction Temperature (Note 2)	175°C
Storage Temperature Range	-65°C ≤ T _A ≤ +150°C
Lead Temperature (Soldering, 10 seconds)	260°C
Thermal Resistance	
θ _{JA}	
CERDIP	
(Still Air)	120°C/W
(500LF/Min Air flow)	51°C/W
CERPACK	
(Still Air)	140°C/W
(500LF/Min Air flow)	116°C/W
Ceramic SOIC	
(Still Air)	140°C/W
(500LF/Min Air flow)	116°C/W
θ _{JC}	
CERDIP	35°C/W
CERPACK	60°C/W
Ceramic SOIC	60°C/W
Package Weight (Typical)	
CERDIP	TBD
CERPACK	460mg
Ceramic SOIC	410mg
ESD Tolerance (Note 5)	250V

Quality Conformance Inspection

MIL-STD-883, Method 5005 — Group A

Subgroup	Description	Temp (°C)
1	Static tests at	25
2	Static tests at	125
3	Static tests at	-55
4	Dynamic tests at	25
5	Dynamic tests at	125
6	Dynamic tests at	-55
7	Functional tests at	25
8A	Functional tests at	125
8B	Functional tests at	-55
9	Switching tests at	25
10	Switching tests at	125
11	Switching tests at	-55

LM124 JAN DC Electrical Characteristics

SYMBOL	PARAMETER	CONDITIONS	NOTES	MIN	MAX	UNIT	SUB GROUPS
V_{IO}	Input Offset Voltage	$V_{CC}^+ = 30V, V_{CC}^- = \text{Gnd},$ $V_{CM} = -15V$		-5.0	5.0	mV	1
				-7.0	7.0	mV	2, 3
		$V_{CC}^+ = 2V, V_{CC}^- = -28V,$ $V_{CM} = 13V$		-5.0	5.0	mV	1
				-7.0	7.0	mV	2, 3
		$V_{CC}^+ = 5V, V_{CC}^- = \text{Gnd},$ $V_{CM} = -1.4V$		-5.0	5.0	mV	1
	-7.0	7.0	mV	2, 3			
I_{IO}	Input Offset Current	$V_{CC}^+ = 30V, V_{CC}^- = \text{Gnd},$ $V_{CM} = -15V$		-30	30	nA	1, 2
				-75	75	nA	3
		$V_{CC}^+ = 2V, V_{CC}^- = -28V,$ $V_{CM} = 13V$		-30	30	nA	1, 2
				-75	75	nA	3
		$V_{CC}^+ = 5V, V_{CC}^- = \text{Gnd},$ $V_{CM} = -1.4V$		-30	30	nA	1, 2
	-75	75	nA	3			
$\pm I_{IB}$	Input Bias Current	$V_{CC}^+ = 30V, V_{CC}^- = \text{Gnd},$ $V_{CM} = -15V$		-150	+0.1	nA	1, 2
				-300	+0.1	nA	3
		$V_{CC}^+ = 2V, V_{CC}^- = -28V,$ $V_{CM} = 13V$		-150	+0.1	nA	1, 2
				-300	+0.1	nA	3
		$V_{CC}^+ = 5V, V_{CC}^- = \text{Gnd},$ $V_{CM} = -1.4V$		-150	+0.1	nA	1, 2
	-300	+0.1	nA	3			
+PSRR	Power Supply Rejection Ratio	$V_{CC}^- = \text{Gnd}, V_{CM} = -1.4V,$ $5V \leq V_{CC}^+ \leq 30V$		-100	100	$\mu\text{V}/\text{V}$	1, 2, 3
CMRR	Common Mode Rejection Ratio		(Note 6)	76		dB	1, 2, 3
I_{OS}^+	Output Short Circuit Current	$V_{CC}^+ = 30V, V_{CC}^- = \text{Gnd},$ $V_O = +25V$		-70		mA	1, 2, 3
I_{CC}	Power Supply Current	$V_{CC}^+ = 30V, V_{CC}^- = \text{Gnd}$			3	mA	1, 2
					4	mA	3
Delta V_{IO} / Delta T	Input Offset Voltage Temperature Sensitivity	$+25^\circ\text{C} \leq T_A \leq +125^\circ\text{C},$ $V_{CC}^+ = 5V, V_{CC}^- = 0V,$ $V_{CM} = -1.4V$		-30	30	$\mu\text{V}/^\circ\text{C}$	2
				-30	30	$\mu\text{V}/^\circ\text{C}$	3
Delta I_{IO} / Delta T	Input Offset Current Temperature Sensitivity	$+25^\circ\text{C} \leq T_A \leq +125^\circ\text{C},$ $V_{CC}^+ = 5V, V_{CC}^- = 0V,$ $V_{CM} = -1.4V$		-400	400	$\text{pA}/^\circ\text{C}$	2
				-700	700	$\text{pA}/^\circ\text{C}$	3

LM124 JAN DC Electrical Characteristics

SYMBOL	PARAMETER	CONDITIONS	NOTES	MIN	MAX	UNIT	SUB GROUPS
V_{OL}	Logical "0" Output Voltage	$V_{CC}^+ = 30V, V_{CC}^- = Gnd,$ $R_L = 10K\Omega$			35	mV	4, 5, 6
		$V_{CC}^+ = 30V, V_{CC}^- = Gnd,$ $I_{OL} = 5mA$			1.5	V	4, 5, 6
		$V_{CC}^+ = 4.5V, V_{CC}^- = Gnd,$ $I_{OL} = 2\mu A$			0.4	V	4, 5, 6
V_{OH}	Logical "1" Output Voltage	$V_{CC}^+ = 30V, V_{CC}^- = Gnd,$ $I_{OH} = -10mA$		27		V	4, 5, 6
		$V_{CC}^+ = 4.5V, V_{CC}^- = Gnd,$ $I_{OH} = -10mA$		2.4		V	4, 5
				2.3		V	6
A_{VS}^+	Voltage Gain	$V_{CC}^+ = 30V, V_{CC}^- = Gnd,$ $1V \leq V_O \leq 26V,$ $R_L = 10K\Omega$		50		V/mV	4
				25		V/mV	5, 6
		$V_{CC}^+ = 30V, V_{CC}^- = Gnd,$ $5V \leq V_O \leq 20V,$ $R_L = 2K\Omega$		50		V/mV	4
				25		V/mV	5, 6
A_{VS}	Gain Voltage	$V_{CC}^+ = 5V, V_{CC}^- = Gnd,$ $1V \leq V_O \leq 2.5V,$ $R_L = 10K\Omega$		10		V/mV	4, 5, 6
		$V_{CC}^+ = 5V, V_{CC}^- = Gnd,$ $1V \leq V_O \leq 2.5V,$ $R_L = 2K\Omega$		10		V/mV	4, 5, 6
$+V_{OP}$	Maximum Output Voltage Swing	$V_{CC}^+ = 30V, V_{CC}^- = Gnd,$ $V_O = +30V, R_L = 10K\Omega$		27		V	4, 5, 6
		$V_{CC}^+ = 30V, V_{CC}^- = Gnd,$ $V_O = +30V, R_L = 2K\Omega$		26		V	4, 5, 6

LM124 JAN AC Electrical Characteristics

The following conditions apply to all the following parameters, unless otherwise specified. AC: $+V_{CC} = 30V$, $-V_{CC} = 0V$.

SYMBOL	PARAMETER	CONDITIONS	NOTES	MIN	MAX	UNIT	SUB GROUPS
TR_{TR}	Transient Response: Rise Time	$V_{CC}^+ = 30V$, $V_{CC}^- = Gnd$			1.0	μS	7, 8A, 8B
TR_{OS}	Transient Response: Overshoot	$V_{CC}^+ = 30V$, $V_{CC}^- = Gnd$			50	%	7, 8A, 8B
$\pm S_R$	Slew Rate: Rise/Fall	$V_{CC}^+ = 30V$, $V_{CC}^- = Gnd$		0.1		$V/\mu S$	7, 8A, 8B
NI_{BB}	Noise Broadband	$V_{CC}^+ = 15V$, $V_{CC}^- = -15V$, $BW = 10Hz$ to $5KHz$			15	$\mu V/rms$	7
NI_{PC}	Noise Popcorn	$V_{CC}^+ = 15V$, $V_{CC}^- = -15V$, $R_s = 20K\Omega$			50	$\mu V/pK$	7
C_S	Channel Separation	$V_{CC}^+ = 30V$, $V_{CC}^- = Gnd$, $V_{IN} = 1V$ and $16V$, $R_L = 2K\Omega$		80		dB	7

LM124 JAN DC — Drift Values

“Delta calculations performed on JAN S and QMLV devices at group B, subgroup 5 only”

SYMBOL	PARAMETER	CONDITIONS	NOTES	MIN	MAX	UNIT	SUB GROUPS
V_{IO}	Input Offset Voltage	$V_{CC}^+ = 30V$, $V_{CC}^- = Gnd$, $V_{CM} = -15V$		-1.0	1.0	mV	1
$\pm I_{IB}$	Input Bias Current	$V_{CC}^+ = 30V$, $V_{CC}^- = Gnd$, $V_{CM} = -15V$		-15	15	nA	1

LM124A JAN DC Electrical Characteristics

SYMBOL	PARAMETER	CONDITIONS	NOTES	MIN	MAX	UNIT	SUB GROUPS
V_{IO}	Input Offset Voltage	$V_{CC}^+ = 30V, V_{CC}^- = \text{Gnd},$ $V_{CM} = -15V$		-2.0	2.0	mV	1
				-4.0	4.0	mV	2, 3
		$V_{CC}^+ = 2V, V_{CC}^- = -28V,$ $V_{CM} = 13V$		-2.0	2.0	mV	1
				-4.0	4.0	mV	2, 3
		$V_{CC}^+ = 5V, V_{CC}^- = \text{Gnd},$ $V_{CM} = -1.4V$		-2.0	2.0	mV	1
				-4.0	4.0	mV	2, 3
I_{IO}	Input Offset Current	$V_{CC}^+ = 30V, V_{CC}^- = \text{Gnd},$ $V_{CM} = -15V$		-10	10	nA	1, 2
				-30	30	nA	3
		$V_{CC}^+ = 2V, V_{CC}^- = -28V,$ $V_{CM} = 13V$		-10	10	nA	1, 2
				-30	30	nA	3
		$V_{CC}^+ = 5V, V_{CC}^- = \text{Gnd},$ $V_{CM} = -1.4V$		-10	10	nA	1, 2
				-30	30	nA	3
$\pm I_{IB}$	Input Bias Current	$V_{CC}^+ = 30V, V_{CC}^- = \text{Gnd},$ $V_{CM} = -15V$		-50	+0.1	nA	1, 2
				-100	+0.1	nA	3
		$V_{CC}^+ = 2V, V_{CC}^- = -28V,$ $V_{CM} = 13V$		-50	+0.1	nA	1, 2
				-100	+0.1	nA	3
		$V_{CC}^+ = 5V, V_{CC}^- = \text{Gnd},$ $V_{CM} = -1.4V$		-50	+0.1	nA	1, 2
				-100	+0.1	nA	3
$V_{CC}^+ = 2.5V, V_{CC}^- = -2.5V, V_{CM}$ $= 1.1V$	-10	10	nA	1, 2			
	-30	30	nA	3			
+PSRR	Power Supply Rejection Ratio	$V_{CC}^- = \text{Gnd}, V_{CM} = -1.4V,$ $5V \leq V_{CC} \leq 30V$		-100	100	$\mu\text{V/V}$	1, 2, 3
CMRR	Common Mode Rejection Ratio		(Note 6)	76		dB	1, 2, 3
I_{OS+}	Output Short Circuit Current	$V_{CC}^+ = 30V, V_{CC}^- = \text{Gnd},$ $V_O = +25V$		-70		mA	1, 2, 3
I_{CC}	Power Supply Current	$V_{CC}^+ = 30V, V_{CC}^- = \text{Gnd}$			3.0	mA	1, 2
					4.0	mA	3
Delta V_{IO} / Delta T	Input Offset Voltage Temperature Sensitivity	$+25^\circ\text{C} \leq T_A \leq +125^\circ\text{C},$ $V_{CC}^+ = 5V, V_{CC}^- = 0V,$ $V_{CM} = -1.4V$		-30	30	$\mu\text{V}/^\circ\text{C}$	2
Delta I_{IO} / Delta T	Input Offset Current Temperature Sensitivity	$+25^\circ\text{C} \leq T_A \leq +125^\circ\text{C},$ $V_{CC}^+ = 5V, V_{CC}^- = 0V,$ $V_{CM} = -1.4V$		-400	400	$\text{pA}/^\circ\text{C}$	2
		$-55^\circ\text{C} \leq T_A \leq +25^\circ\text{C},$ $V_{CC}^+ = 5V, V_{CC}^- = 0V,$ $V_{CM} = -1.4V$		-700	700	$\text{pA}/^\circ\text{C}$	3

LM124A JAN DC Electrical Characteristics

SYMBOL	PARAMETER	CONDITIONS	NOTES	MIN	MAX	UNIT	SUB GROUPS
V_{OL}	Logical "0" Output Voltage	$V_{CC}^+ = 30V, V_{CC}^- = Gnd,$ $R_L = 10K\Omega$			35	mV	4, 5, 6
		$V_{CC}^+ = 30V, V_{CC}^- = Gnd,$ $I_{OL} = 5mA$			1.5	V	4, 5, 6
		$V_{CC}^+ = 4.5V, V_{CC}^- = Gnd,$ $I_{OL} = 2\mu A$			0.4	V	4, 5, 6
V_{OH}	Logical "1" Output Voltage	$V_{CC}^+ = 30V, V_{CC}^- = Gnd,$ $I_{OH} = -10mA$		27		V	4, 5, 6
		$V_{CC}^+ = 4.5V, V_{CC}^- = Gnd,$ $I_{OH} = -10mA$		2.4		V	4, 5
				2.3		V	6
A_{VS}^+	Voltage Gain	$V_{CC}^+ = 30V, V_{CC}^- = Gnd,$ $1V \leq V_O \leq 26V,$ $R_L = 10K\Omega$		50		V/mV	4
				25		V/mV	5, 6
		$V_{CC}^+ = 30V, V_{CC}^- = Gnd,$ $5V \leq V_O \leq 20V,$ $R_L = 2K\Omega$		50		V/mV	4
				25		V/mV	5, 6
A_{VS}	Gain Voltage	$V_{CC}^+ = 5V, V_{CC}^- = Gnd,$ $1V \leq V_O \leq 2.5V,$ $R_L = 10K\Omega$		10		V/mV	4, 5, 6
		$V_{CC}^+ = 5V, V_{CC}^- = Gnd,$ $1V \leq V_O \leq 2.5V,$ $R_L = 2K\Omega$		10		V/mV	4, 5, 6
$+V_{OP}$	Maximum Output Voltage Swing	$V_{CC}^+ = 30V, V_{CC}^- = Gnd,$ $V_O = +30V, R_L = 10K\Omega$		27		V	4, 5, 6
		$V_{CC}^+ = 30V, V_{CC}^- = Gnd,$ $V_O = +30V, R_L = 2K\Omega$		26		V	4, 5, 6

LM124A JAN AC Electrical Characteristics

The following conditions apply to all the following parameters, unless otherwise specified. AC: $+V_{CC} = 30V$, $-V_{CC} = 0V$

SYMBOL	PARAMETER	CONDITIONS	NOTES	MIN	MAX	UNIT	SUB GROUPS
TR _{TR}	Transient Response: Rise Time	$V_{CC}^+ = 30V$, $V_{CC}^- = Gnd$			1.0	μS	7, 8A, 8B
TR _{OS}	Transient Response: Overshoot	$V_{CC}^+ = 30V$, $V_{CC}^- = Gnd$			50	%	7, 8A, 8B
$\pm S_R$	Slew Rate: Rise/Fall	$V_{CC}^+ = 30V$, $V_{CC}^- = Gnd$		0.1		$V/\mu S$	7, 8A, 8B
NI _{BB}	Noise Broadband	$V_{CC}^+ = 15V$, $V_{CC}^- = -15V$, BW = 10Hz to 5KHz			15	$\mu V/rms$	7
NI _{PC}	Noise Popcorn	$V_{CC}^+ = 15V$, $V_{CC}^- = -15V$, Rs = 20K Ω BW = 10Hz to 5KHz			50	$\mu V/pK$	7
C _S	Channel Separation	$V_{CC}^+ = 30V$, $V_{CC}^- = Gnd$ R _L = 2K Ω		80		dB	7
		$V_{CC}^+ = 30V$, $V_{CC}^- = Gnd$, V _{IN} = 1V and 16V, R _L = 2K Ω		80		dB	7

LM124A JAN DC — Drift Values

“Delta calculations performed on JAN S and QMLV devices at group B, subgroup 5 only”

Symbol	PARAMETER	CONDITIONS	NOTES	MIN	MAX	UNIT	SUB GROUPS
V_{io}	Input Offset Voltage	$V_{cc}^+ = 30V, V_{cc}^- = Gnd,$ $V_{cm} = -15V$		-0.5	0.5	mV	1
$\pm i_{ib}$	Input Bias Current	$V_{cc}^+ = 30V, V_{cc}^- = Gnd,$ $V_{cm} = -15V$		-10	10	nA	1

Note 1: Absolute Maximum Ratings indicate limits beyond which damage to the device may occur. Operating Ratings indicate conditions for which the device is functional, but do not guarantee specific performance limits. For guaranteed specifications and test conditions, see the Electrical Characteristics. The guaranteed specifications apply only for the test conditions listed. Some performance characteristics may degrade when the device is not operated under the listed test conditions.

Note 2: The maximum power dissipation must be derated at elevated temperatures and is dictated by T_{Jmax} (maximum junction temperature), θ_{JA} (package junction to ambient thermal resistance), and T_A (ambient temperature). The maximum allowable power dissipation at any temperature is $P_{Dmax} = (T_{Jmax} - T_A)/\theta_{JA}$ or the number given in the Absolute Maximum Ratings, whichever is lower.

Note 3: This input current will only exist when the voltage at any of the input leads is driven negative. It is due to the collector-base junction of the input PNP transistors becoming forward biased and thereby acting as input diode clamps. In addition to this diode action, there is also lateral NPN parasitic transistor action on the IC chip. This transistor action can cause the output voltages of the op amps to go to the V^+ voltage level (or to ground for a large overdrive) for the time duration that an input is driven negative. This is not destructive and normal output states will re-establish when the input voltage, which was negative, again returns to a value greater than $-0.3V_{DC}$ (at 25°C).

Note 4: Short circuits from the output to V^+ can cause excessive heating and eventual destruction. When considering short circuits to ground, the maximum output current is approximately 40mA independent of the magnitude of V^+ . At values of supply voltage in excess of $+15V_{DC}$, continuous short-circuits can exceed the power dissipation ratings and cause eventual destruction. Destructive dissipation can result from simultaneous shorts on all amplifiers.

Note 5: Human body model, 1.5 k Ω in series with 100 pF.

Note 6: The input common-mode voltage of either input signal voltage should not be allowed to go negative by more than 0.3V (at 25°C). The upper end of the common-mode voltage range is $V^+ - 1.5V$ (at 25°C), but either or both inputs can go to +32V without damage independent of the magnitude of V^+ .

Typical Performance Characteristics

Input Voltage Range

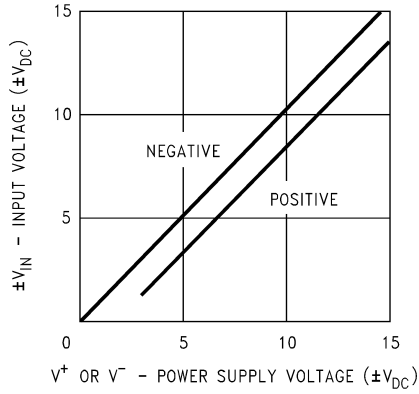

20100734

Input Current

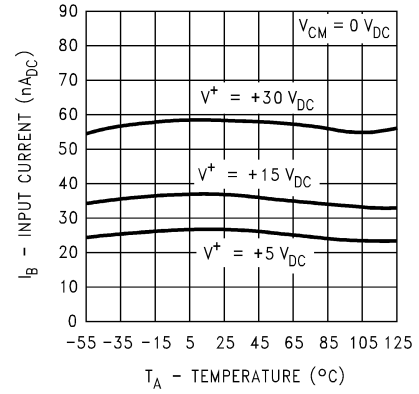

20100735

Supply Current

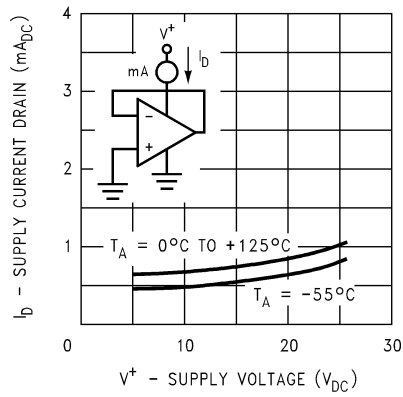

20100736

Voltage Gain

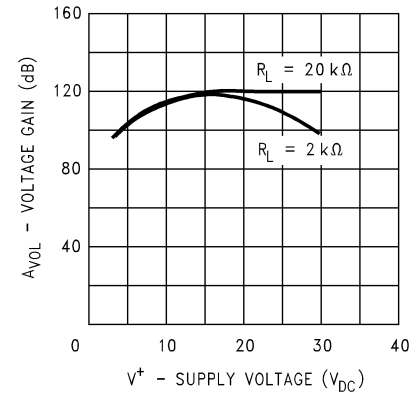

20100737

Open Loop Frequency Response

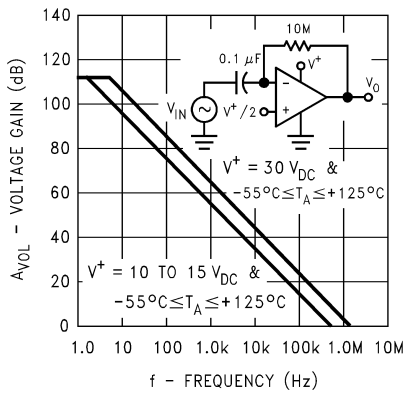

20100738

Common Mode Rejection Ratio

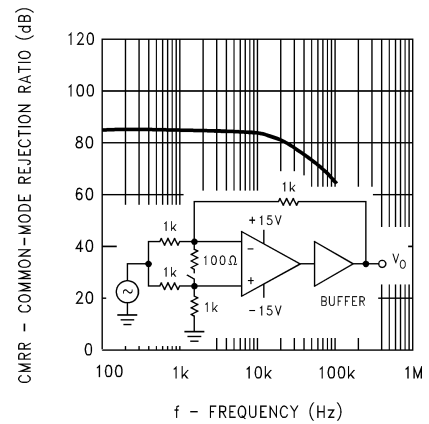

20100739

Typical Performance Characteristics (Continued)

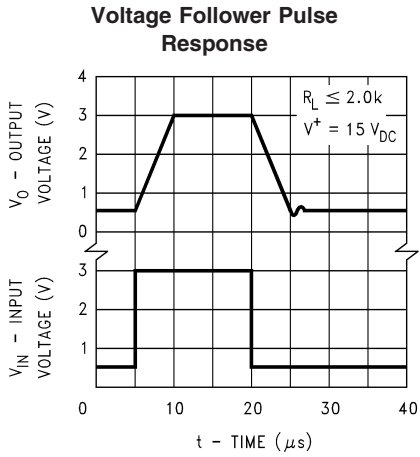

20100740

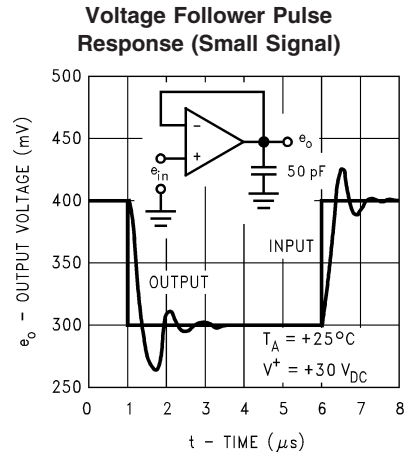

20100741

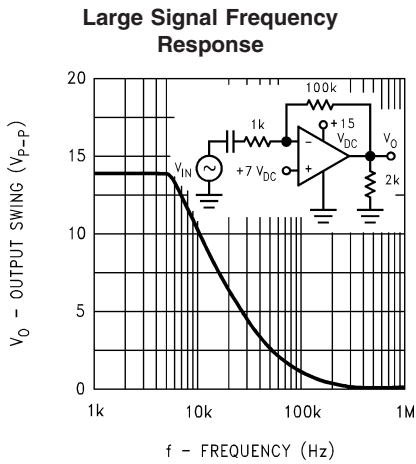

20100742

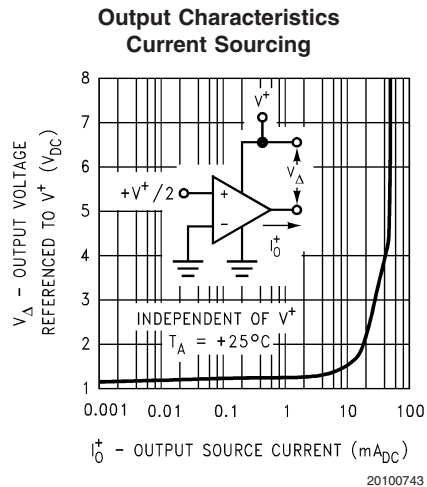

20100743

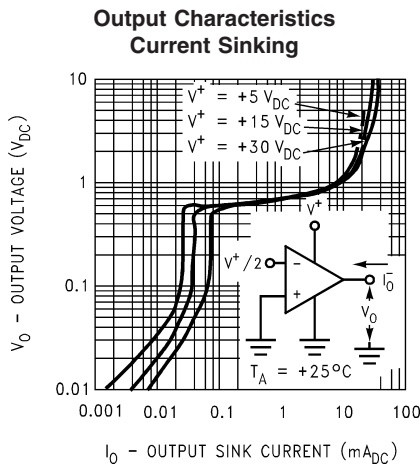

20100744

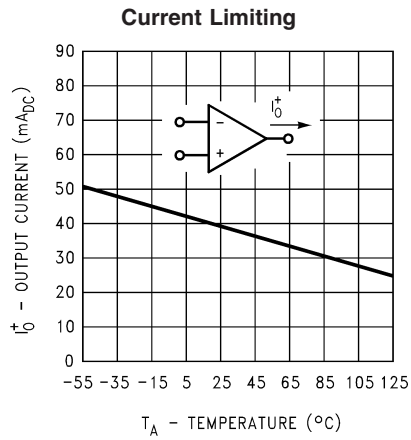

20100745

Typical Performance Characteristics (Continued)

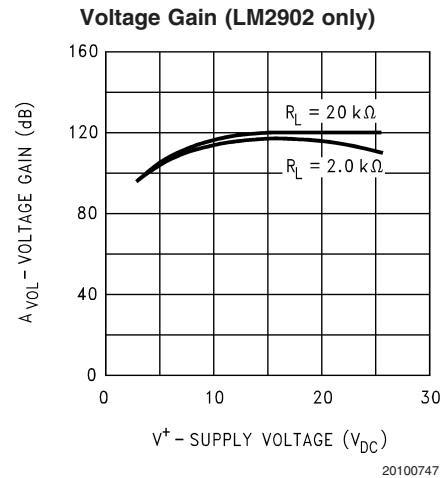
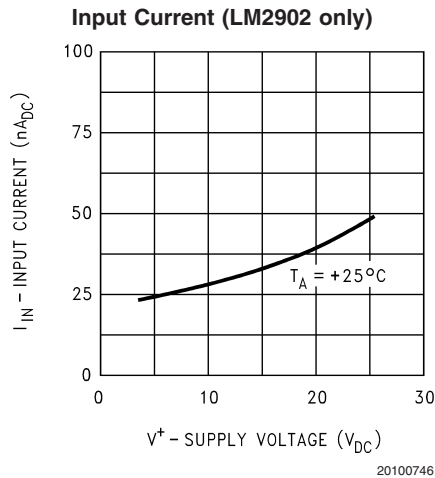

Application Hints

The LM124MIL series are op amps which operate with only a single power supply voltage, have true-differential inputs, and remain in the linear mode with an input common-mode voltage of 0 V_{DC}. These amplifiers operate over a wide range of power supply voltage with little change in performance characteristics. At 25°C amplifier operation is possible down to a minimum supply voltage of 2.3 V_{DC}.

The pinouts of the package have been designed to simplify PC board layouts. Inverting inputs are adjacent to outputs for all of the amplifiers and the outputs have also been placed at the corners of the package (pins 1, 7, 8, and 14).

Precautions should be taken to insure that the power supply for the integrated circuit never becomes reversed in polarity or that the unit is not inadvertently installed backwards in a test socket as an unlimited current surge through the resulting forward diode within the IC could cause fusing of the internal conductors and result in a destroyed unit.

Large differential input voltages can be easily accommodated and, as input differential voltage protection diodes are not needed, no large input currents result from large differential input voltages. The differential input voltage may be larger than V⁺ without damaging the device. Protection should be provided to prevent the input voltages from going negative more than -0.3 V_{DC} (at 25°C). An input clamp diode with a resistor to the IC input terminal can be used.

To reduce the power supply drain, the amplifiers have a class A output stage for small signal levels which converts to class B in a large signal mode. This allows the amplifiers to both source and sink large output currents. Therefore both NPN and PNP external current boost transistors can be used to extend the power capability of the basic amplifiers. The output voltage needs to raise approximately 1 diode drop above ground to bias the on-chip vertical PNP transistor for output current sinking applications.

For ac applications, where the load is capacitively coupled to the output of the amplifier, a resistor should be used, from the output of the amplifier to ground to increase the class A bias current and prevent crossover distortion.

Where the load is directly coupled, as in dc applications, there is no crossover distortion.

Capacitive loads which are applied directly to the output of the amplifier reduce the loop stability margin. Values of 50 pF can be accommodated using the worst-case non-inverting unity gain connection. Large closed loop gains or resistive isolation should be used if larger load capacitance must be driven by the amplifier.

The bias network of the LM124MIL establishes a drain current which is independent of the magnitude of the power supply voltage over the range of from 3 V_{DC} to 30 V_{DC}.

Output short circuits either to ground or to the positive power supply should be of short time duration. Units can be destroyed, not as a result of the short circuit current causing metal fusing, but rather due to the large increase in IC chip dissipation which will cause eventual failure due to excessive junction temperatures. Putting direct short-circuits on more than one amplifier at a time will increase the total IC power dissipation to destructive levels, if not properly protected with external dissipation limiting resistors in series with the output leads of the amplifiers. The larger value of output source current which is available at 25°C provides a larger output current capability at elevated temperatures (see typical performance characteristics) than a standard IC op amp.

The circuits presented in the section on typical applications emphasize operation on only a single power supply voltage. If complementary power supplies are available, all of the standard op amp circuits can be used. In general, introducing a pseudo-ground (a bias voltage reference of V⁺/2) will allow operation above and below this value in single power supply systems. Many application circuits are shown which take advantage of the wide input common-mode voltage range which includes ground. In most cases, input biasing is not required and input voltages which range to ground can easily be accommodated.

Typical Single-Supply Applications

($V^+ = 5.0 V_{DC}$)

Non-Inverting DC Gain (0V Input = 0V Output)

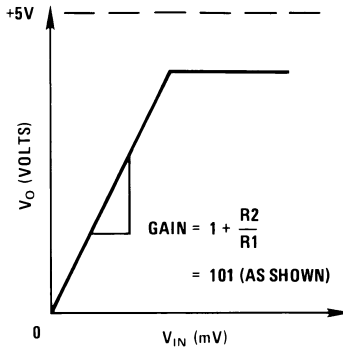
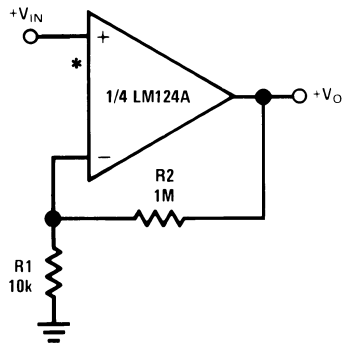

20100705

*R not needed due to temperature independent I_{IN}

DC Summing Amplifier
($V_{IN'S} \geq 0 V_{DC}$ and $V_O \geq V_{DC}$)

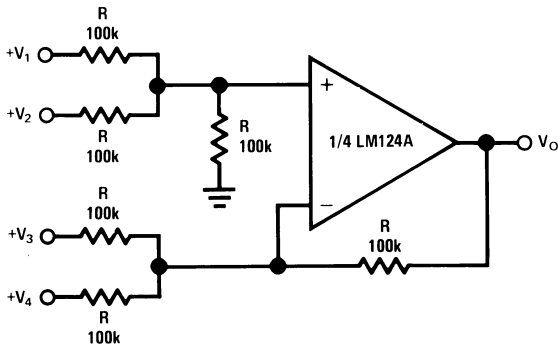

20100706

Where: $V_O = V_1 + V_2 - V_3 - V_4$
($V_1 + V_2$) \geq ($V_3 + V_4$) to keep $V_O > 0 V_{DC}$

Power Amplifier

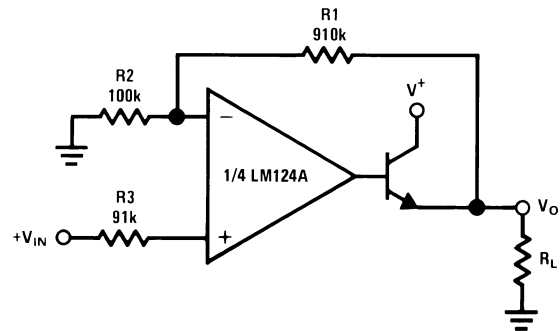

20100707

$V_O = 0 V_{DC}$ for $V_{IN} = 0 V_{DC}$
 $A_V = 10$

Typical Single-Supply Applications ($V^+ = 5.0 V_{DC}$) (Continued)

LED Driver

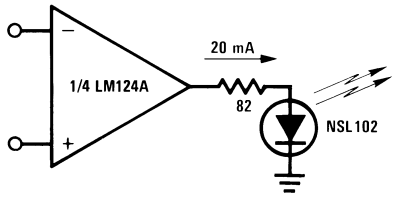

20100708

“BI-QUAD” RC Active Bandpass Filter

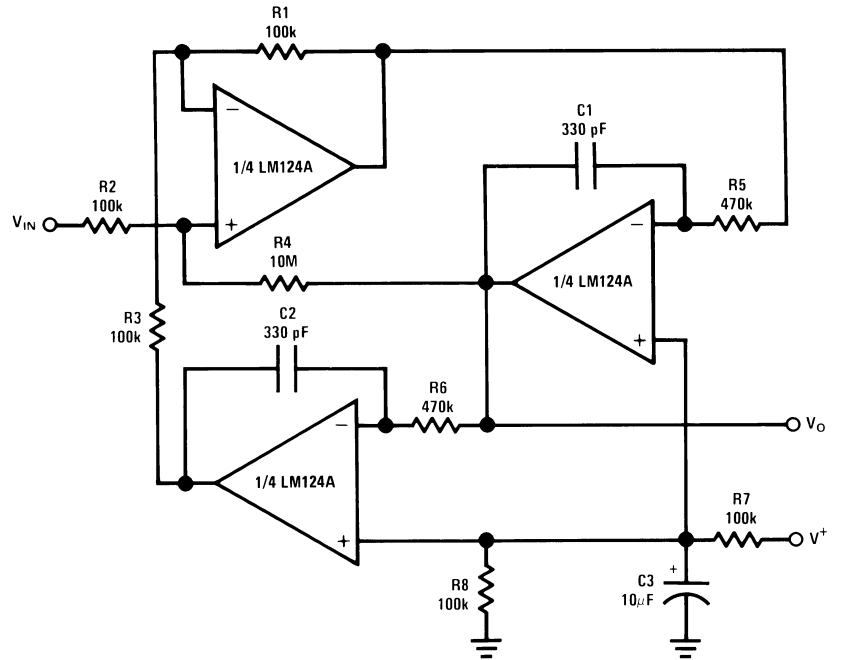

20100709

$f_o = 1 \text{ kHz}$
 $Q = 50$
 $A_V = 100 \text{ (40 dB)}$

Fixed Current Sources

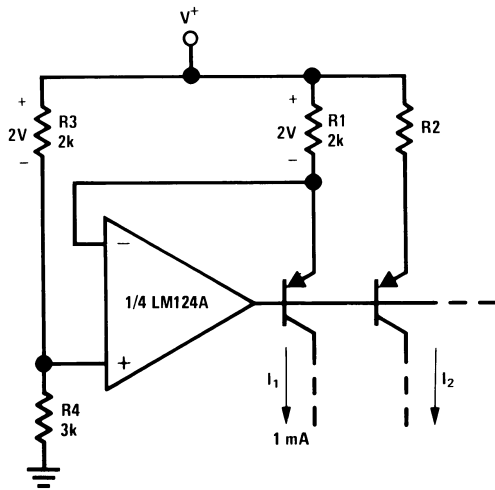

20100710

$$I_2 = \left(\frac{R_1}{R_2}\right) I_1$$

Lamp Driver

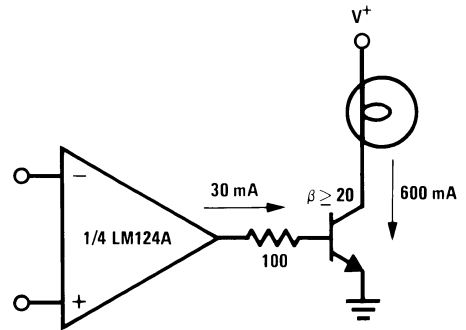

20100711

Typical Single-Supply Applications

($V^+ = 5.0 V_{DC}$) (Continued)

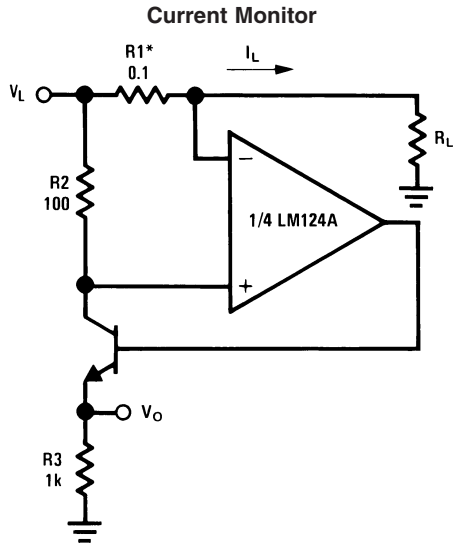

20100712

$$V_O = \frac{1V(I_L)}{1A}$$

$$V_L \leq V^+ - 2V$$

*(Increase R1 for I_L small)

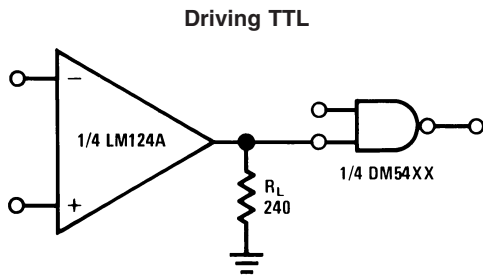

20100713

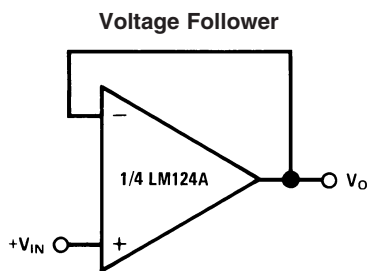

20100714

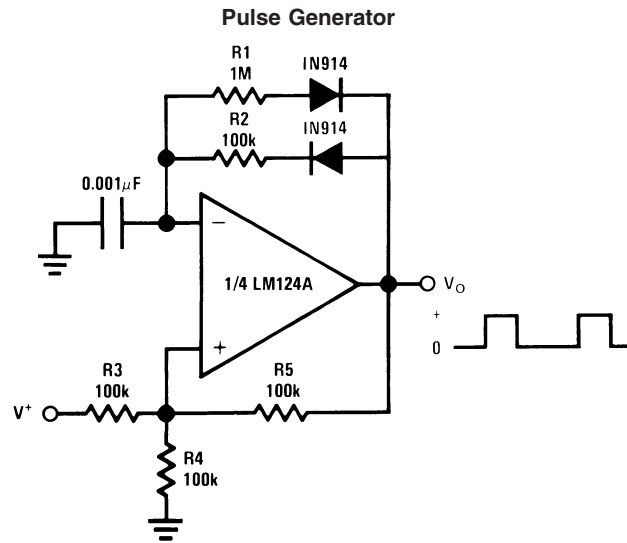

20100715

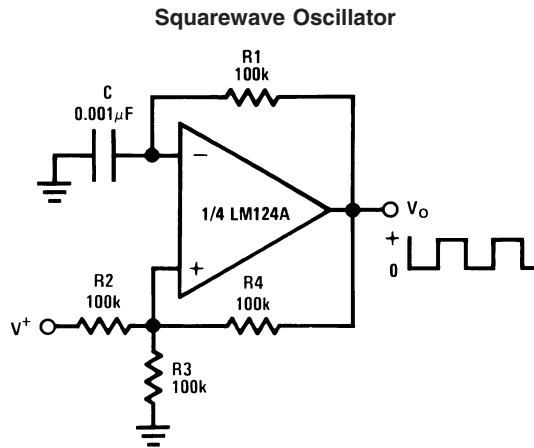

20100716

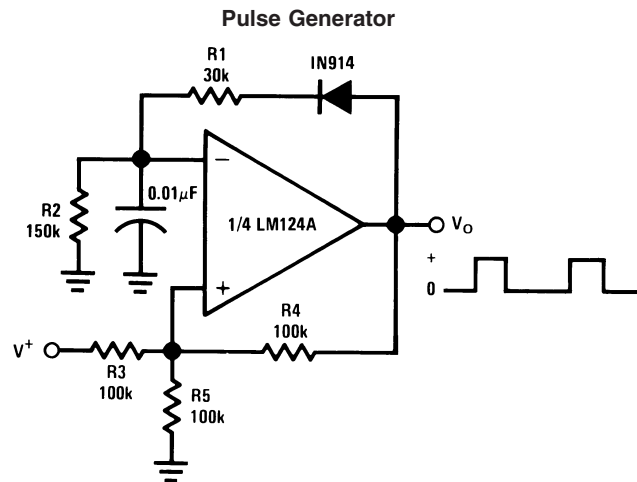

20100717

Typical Single-Supply Applications ($V^+ = 5.0 V_{DC}$) (Continued)

High Compliance Current Sink

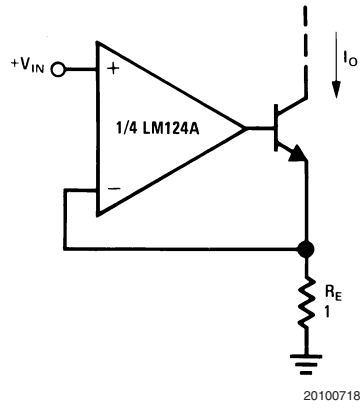

20100718

$I_o = 1 \text{ amp/volt } V_{IN}$
 (Increase R_E for I_o small)

Low Drift Peak Detector

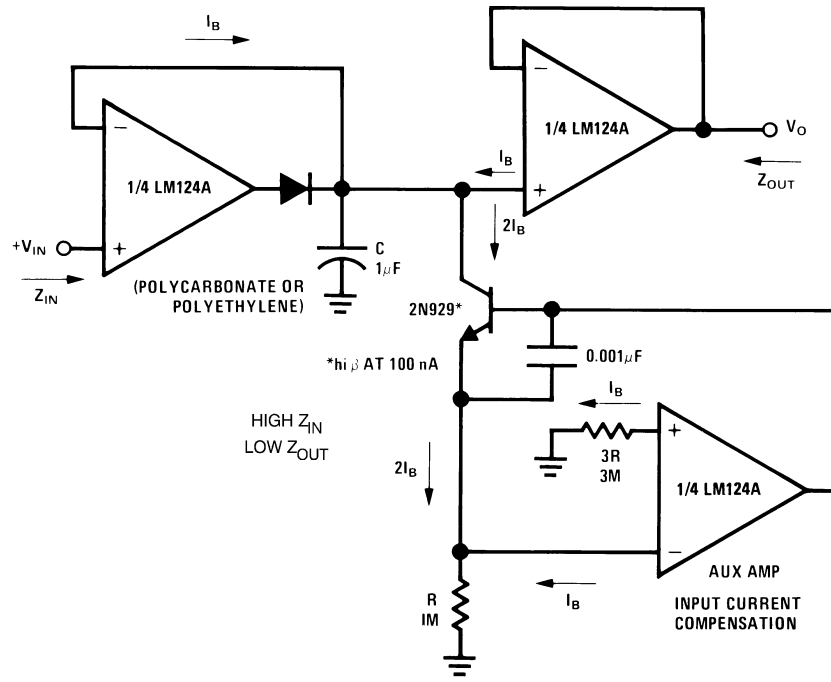

20100719

Typical Single-Supply Applications ($V^+ = 5.0 V_{DC}$) (Continued)

Comparator with Hysteresis

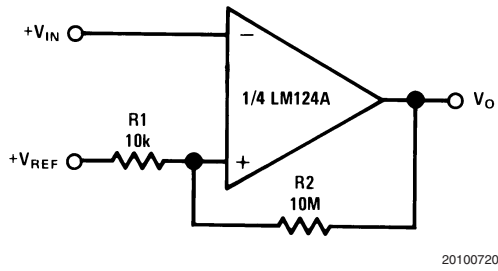

Ground Referencing a Differential Input Signal

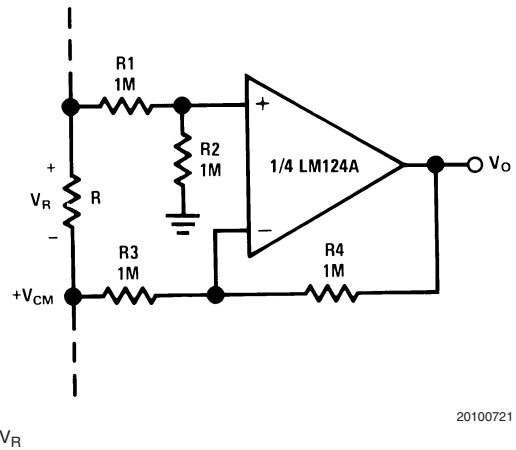

Voltage Controlled Oscillator Circuit

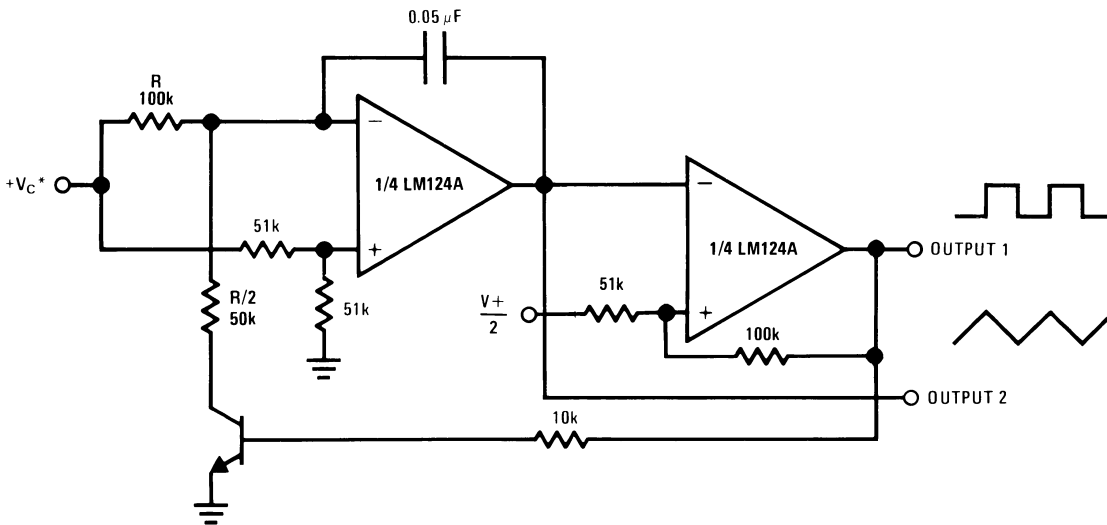

*Wide control voltage range: $0 V_{DC} \leq V_C \leq 2 (V^+ - 1.5 V_{DC})$

Photo Voltaic-Cell Amplifier

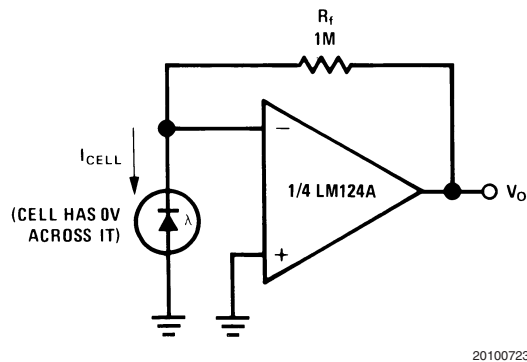

Typical Single-Supply Applications ($V^+ = 5.0 V_{DC}$) (Continued)

AC Coupled Inverting Amplifier

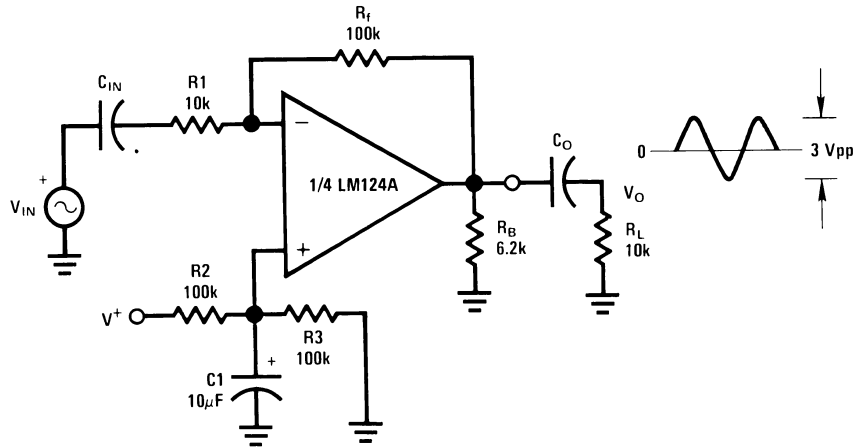

20100724

$$A_V = \frac{R_f}{R_1} \text{ (As shown, } A_V = 10 \text{)}$$

AC Coupled Non-Inverting Amplifier

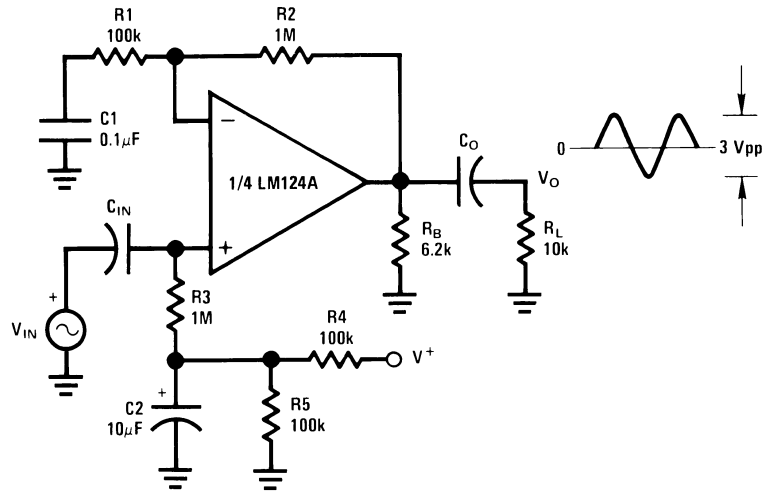

20100725

$$A_V = 1 + \frac{R_2}{R_1}$$

$$A_V = 11 \text{ (As shown)}$$

Typical Single-Supply Applications ($V^+ = 5.0 V_{DC}$) (Continued)

DC Coupled Low-Pass RC Active Filter

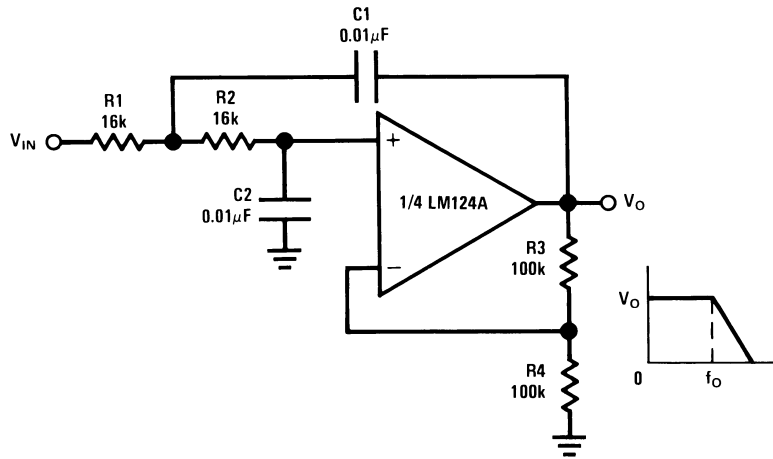

20100726

$f_0 = 1 \text{ kHz}$
 $Q = 1$
 $A_V = 2$

High Input Z, DC Differential Amplifier

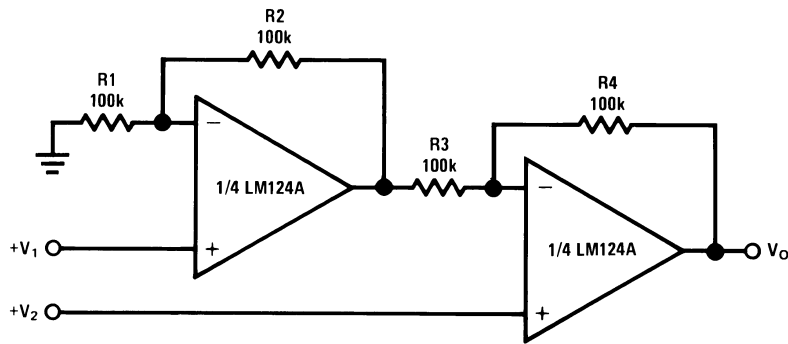

20100727

For $\frac{R1}{R2} = \frac{R4}{R3}$ (CMRR depends on this resistor ratio match)

$V_O = 1 + \frac{R4}{R3} (V_2 - V_1)$

As shown: $V_O = 2(V_2 - V_1)$

Typical Single-Supply Applications ($V^+ = 5.0 V_{DC}$) (Continued)

High Input Z Adjustable-Gain DC Instrumentation Amplifier

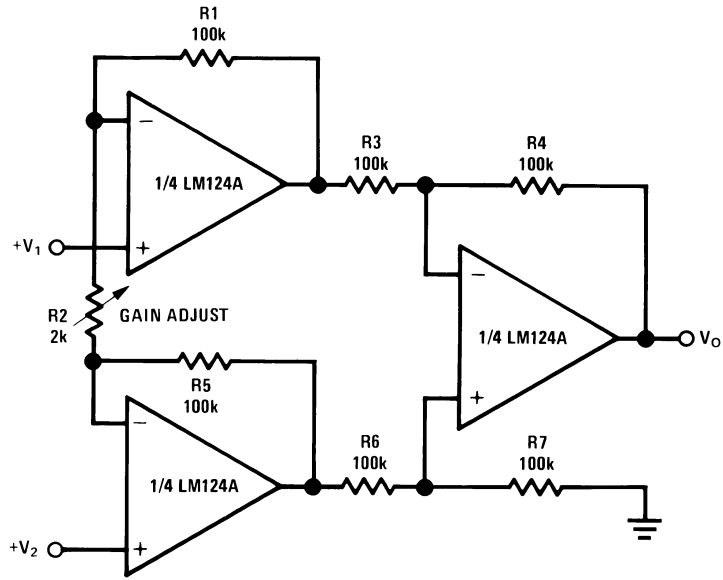

20100728

If $R1 = R5$ & $R3 = R4 = R6 = R7$ (CMRR depends on match)

$$V_O = 1 + \frac{2R1}{R2} (V_2 - V_1)$$

As shown $V_O = 101 (V_2 - V_1)$

Using Symmetrical Amplifiers to Reduce Input Current (General Concept)

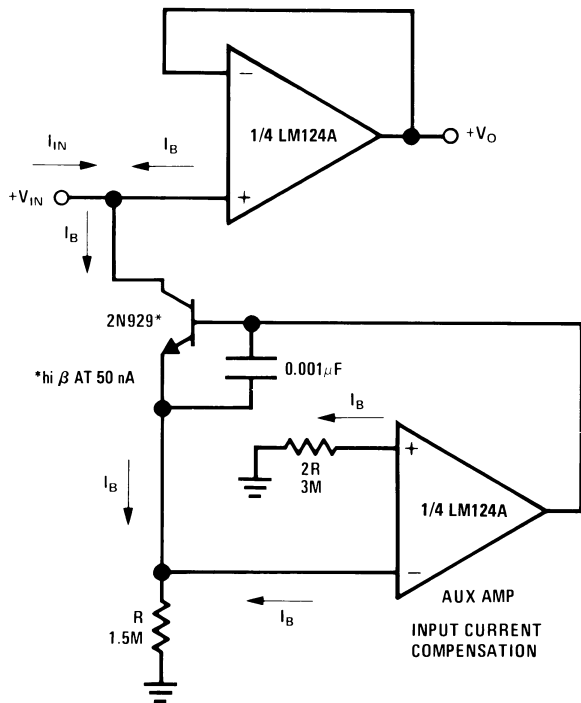

20100729

Bridge Current Amplifier

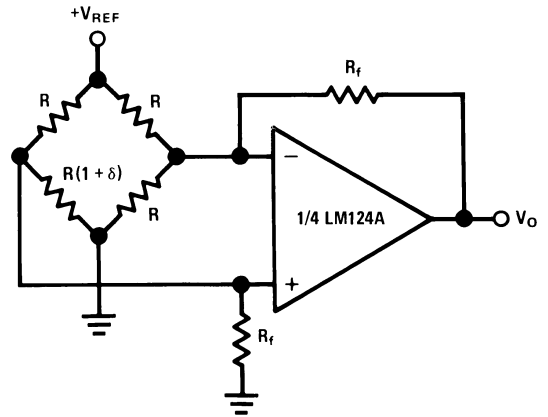

20100730

For $\delta \ll 1$ and $R_f \gg R$

$$V_O \approx V_{REF} \left(\frac{\delta}{2} \right) \frac{R_f}{R}$$

Typical Single-Supply Applications ($V^+ = 5.0 V_{DC}$) (Continued)

Bandpass Active Filter

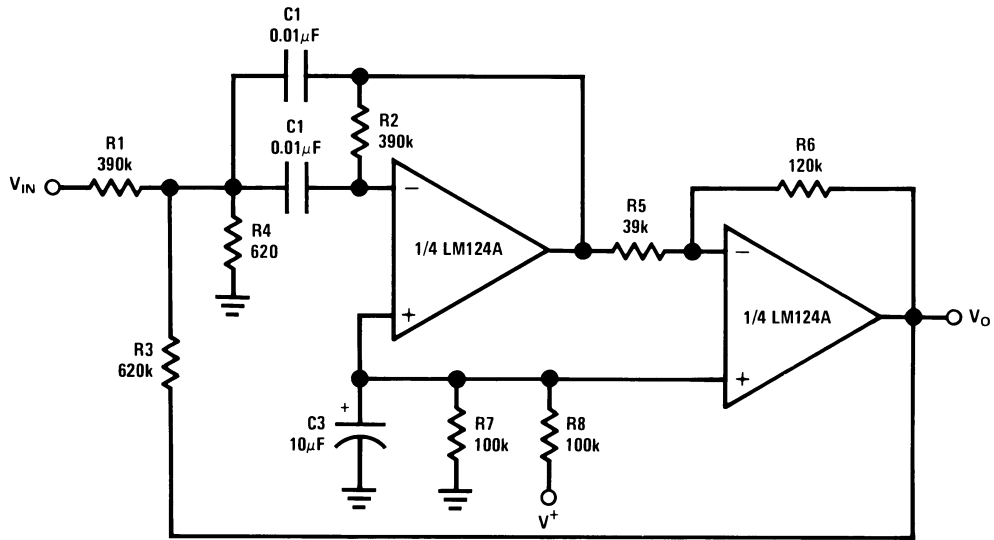

20100731

$f_0 = 1 \text{ kHz}$
 $Q = 25$

Revision History Section

Date Released	Revision	Section	Originator	Changes
01/27/05	A	New Released, Corporate format	R. Malone	2 MDS data sheets converted into one Corp. data sheet format. MJLM124-X, Rev. 1B1 and MJLM124A-X, Rev. 2A1. MDS data sheets will be archived.

Physical Dimensions inches (millimeters) unless otherwise noted (Continued)

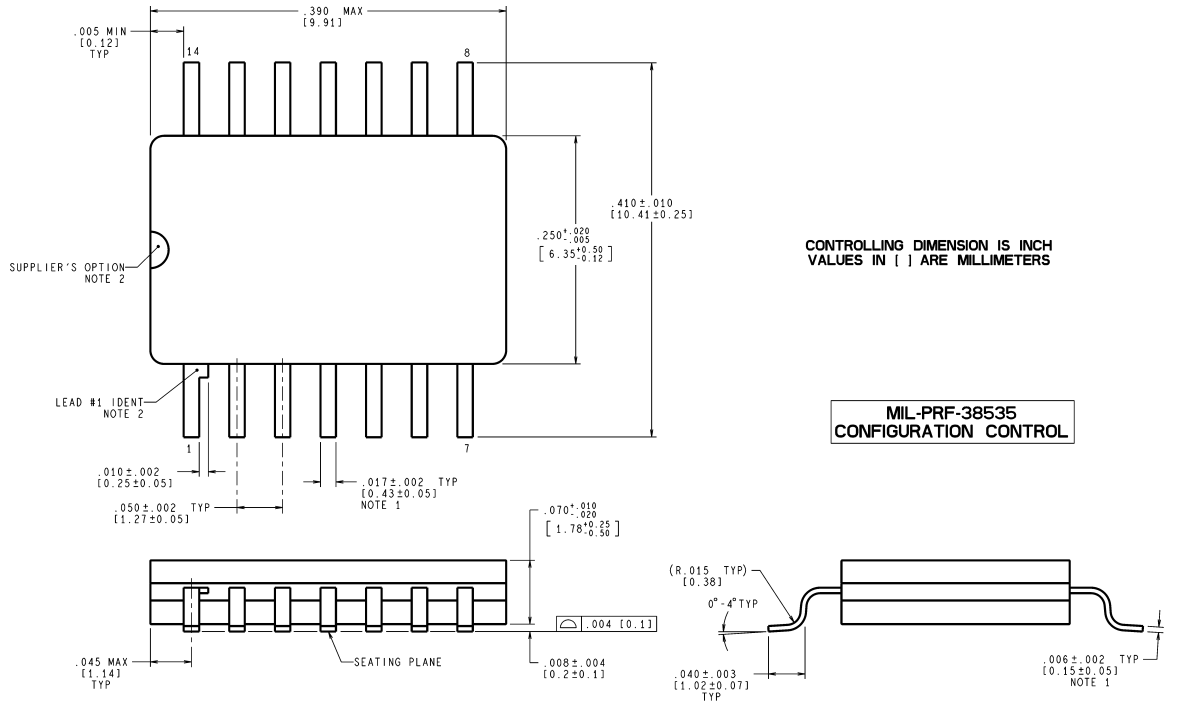

**14-Pin Ceramic Package (WG)
NS Package Number WG14A**

WG14A (Rev C)

National does not assume any responsibility for use of any circuitry described, no circuit patent licenses are implied and National reserves the right at any time without notice to change said circuitry and specifications.

For the most current product information visit us at www.national.com.

LIFE SUPPORT POLICY

NATIONAL'S PRODUCTS ARE NOT AUTHORIZED FOR USE AS CRITICAL COMPONENTS IN LIFE SUPPORT DEVICES OR SYSTEMS WITHOUT THE EXPRESS WRITTEN APPROVAL OF THE PRESIDENT AND GENERAL COUNSEL OF NATIONAL SEMICONDUCTOR CORPORATION. As used herein:

1. Life support devices or systems are devices or systems which, (a) are intended for surgical implant into the body, or (b) support or sustain life, and whose failure to perform when properly used in accordance with instructions for use provided in the labeling, can be reasonably expected to result in a significant injury to the user.
2. A critical component is any component of a life support device or system whose failure to perform can be reasonably expected to cause the failure of the life support device or system, or to affect its safety or effectiveness.

BANNED SUBSTANCE COMPLIANCE

National Semiconductor certifies that the products and packing materials meet the provisions of the Customer Products Stewardship Specification (CSP-9-111C2) and the Banned Substances and Materials of Interest Specification (CSP-9-111S2) and contain no "Banned Substances" as defined in CSP-9-111S2.

 **National Semiconductor**
Americas Customer
Support Center
Email: new.feedback@nsc.com
Tel: 1-800-272-9959

National Semiconductor
Europe Customer Support Center
Fax: +49 (0) 180-530 85 86
Email: europe.support@nsc.com
Deutsch Tel: +49 (0) 69 9508 6208
English Tel: +44 (0) 870 24 0 2171
Français Tel: +33 (0) 1 41 91 8790

National Semiconductor
Asia Pacific Customer
Support Center
Email: ap.support@nsc.com

National Semiconductor
Japan Customer Support Center
Fax: 81-3-5639-7507
Email: jpn.feedback@nsc.com
Tel: 81-3-5639-7560