

74LCX16373 Low-Voltage 16-Bit Transparent Latch with 5V Tolerant Inputs and Outputs

General Description

The LCX16373 contains sixteen non-inverting latches with TRI-STATE® outputs and is intended for bus oriented applications. The device is byte controlled. The flip-flops appear transparent to the data when the Latch Enable (LE) is HIGH. When LE is low, the data that meets the setup time is latched. Data appears on the bus when the Output Enable (OE) is LOW. When OE is HIGH, the outputs are in high Z state.

The LCX16373 is designed for low voltage (3.3V) V_{CC} applications with capability of interfacing to a 5V signal environment.

The LCX16373 is fabricated with an advanced CMOS technology to achieve high speed operation while maintaining CMOS low power dissipation.

Features

- 5.4 ns t_{PD} max, 20 μA I_{CCQ} max
- 5V tolerant inputs and outputs
- Power down high impedance inputs and outputs
- Supports live insertion/withdrawal
- 2.0V–3.6V V_{CC} supply operation
- ± 24 mA output drive
- Implements patented Quiet Series™ noise/EMI reduction circuitry
- Functionally compatible with the 74 series 16373
- Latch-up performance exceeds 500 mA
- ESD performance:
 - Human body model > 2000V
 - Machine model > 200V

Logic Symbol

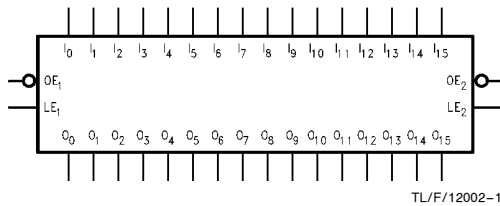

Pin Names	Description
\overline{OE}_n	Output Enable Input (Active Low)
LE_n	Latch Enable Input
I_0-I_{15}	Inputs
O_0-O_{15}	Outputs

	SSOP	TSSOP
Order Number	74LCX16373MEA 74LCX16373MEAX	74LCX16373MTD 74LCX16373MTDX
See NS Package Number	MS48A	MTD48

Connection Diagram

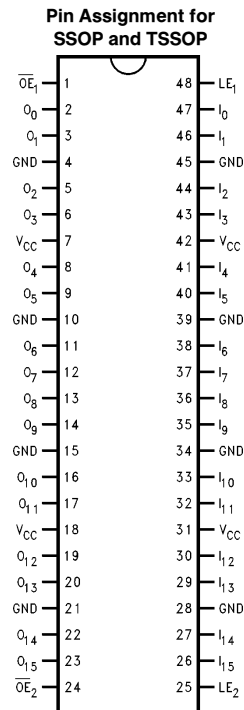

TRI-STATE® is a registered trademark of National Semiconductor Corporation.
Quiet Series™ is a trademark of National Semiconductor Corporation.

Functional Description

The LCX16373 contains sixteen D-type latches with TRI-STATE standard outputs. The device is byte controlled with each byte functioning identically, but independent of the other. Control pins can be shorted together to obtain full 16-bit operation. The following description applies to each byte. When the Latch Enable (LE_n) input is HIGH, data on the D_n enters the latches. In this condition the latches are transparent, i.e. a latch output will change states each time its D input changes. When LE_n is LOW, the latches store information that was present on the D inputs a setup time preceding the HIGH-to-LOW transition of LE_n . The TRI-STATE standard outputs are controlled by the Output Enable (\overline{OE}_n) input. When \overline{OE}_n is LOW, the standard outputs are in the 2-state mode. When \overline{OE}_n is HIGH, the standard outputs are in the high impedance mode but this does not interfere with entering new data into the latches.

Truth Tables

Inputs			Outputs
LE_1	\overline{OE}_1	I_0-I_7	O_0-O_7
X	H	X	Z
H	L	L	L
H	L	H	H
L	L	X	O_0

Inputs			Outputs
LE_2	\overline{OE}_2	I_8-I_{15}	O_8-O_{15}
X	H	X	Z
H	L	L	L
H	L	H	H
L	L	X	O_0

H = High Voltage Level
 L = Low Voltage Level
 X = Immaterial
 Z = High Impedance
 O_0 = Previous O_0 before HIGH to LOW transition of Latch Enable

Logic Diagrams

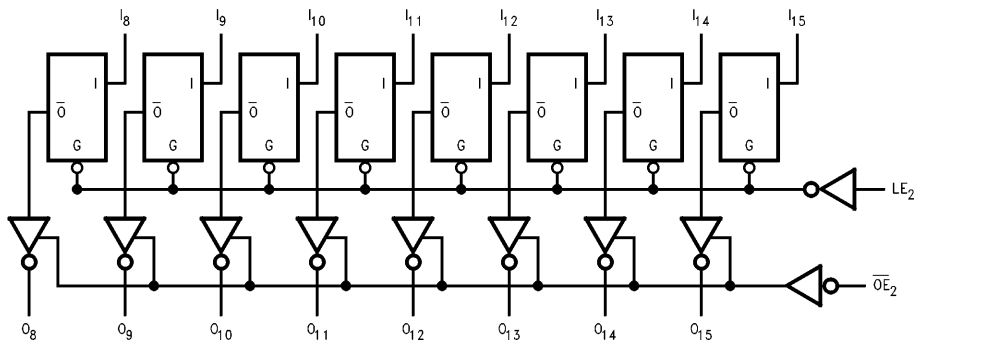
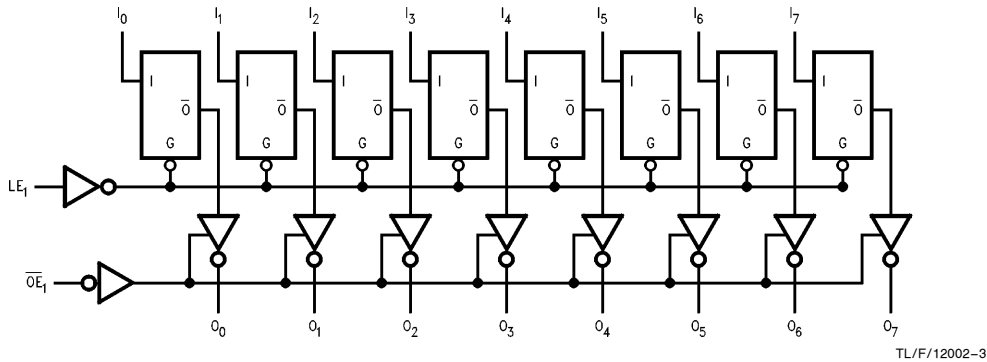

Please note that this diagram is provided only for the understanding of logic operations and should not be used to estimate propagation delays.

Absolute Maximum Ratings (Note 1)

If Military/Aerospace specified devices are required, please contact the National Semiconductor Sales Office/Distributors for availability and specifications.

Symbol	Parameter	Value	Conditions	Units
V _{CC}	Supply Voltage	-0.5 to +7.0		V
V _I	DC Input Voltage	-0.5 to +7.0		V
V _O	DC Output Voltage	-0.5 to +7.0	Output in TRI-STATE	V
		-0.5 to V _{CC} + 0.5	Output in High or Low State (Note 2)	V
I _{IK}	DC Input Diode Current	-50	V _I < GND	mA
I _{OK}	DC Output Diode Current	-50	V _O < GND	mA
		+50	V _O > V _{CC}	
I _O	DC Output Source/Sink Current	±50		mA
I _{CC}	DC Supply Current per Supply Pin	±100		mA
I _{GND}	DC Ground Current per Ground Pin	±100		mA
T _{STG}	Storage Temperature	-65 to +150		°C

Note 1: The Absolute Maximum Ratings are those values beyond which the safety of the device cannot be guaranteed. The device should not be operated at these limits. The parametric values defined in the "Electrical Characteristics" table are not guaranteed at the Absolute Maximum Ratings. The "Recommended Operating Conditions" table will define the conditions for actual device operation.

Note 2: I_O Absolute Maximum Rating must be observed.

Recommended Operating Conditions

Symbol	Parameter	Min	Max	Units	
V _{CC}	Supply Voltage	Operating	2.0	3.6	V
		Data Retention	1.5	3.6	
V _I	Input Voltage	0	5.5	V	
V _O	Output Voltage	HIGH or LOW State	0	V _{CC}	V
		TRI-STATE	0	5.5	
I _{OH} /I _{OL}	Output Current			±24 ±12	mA
T _A	Free-Air Operating Temperature	-40	85	°C	
Δt/ΔV	Input Edge Rate, V _{IN} = 0.8V-2.0V, V _{CC} = 3.0V	0	10	ns/V	

DC Electrical Characteristics

Symbol	Parameter	Conditions	V _{CC} (V)	T _A = -40°C to +85°C		Units
				Min	Max	
V _{IH}	HIGH Level Input Voltage		2.7-3.6	2.0		V
V _{IL}	LOW Level Input Voltage		2.7-3.6		0.8	V
V _{OH}	HIGH Level Output Voltage	I _{OH} = -100 μA	2.7-3.6	V _{CC} - 0.2		V
		I _{OH} = -12 mA	2.7	2.2		V
		I _{OH} = -18 mA	3.0	2.4		V
		I _{OH} = -24 mA	3.0	2.2		V
V _{OL}	LOW Level Output Voltage	I _{OL} = 100 μA	2.7-3.6		0.2	V
		I _{OL} = 12 mA	2.7		0.4	V
		I _{OL} = 16 mA	3.0		0.4	V
		I _{OL} = 24 mA	3.0		0.55	V
I _I	Input Leakage Current	0 ≤ V _I ≤ 5.5V	2.7-3.6		±5.0	μA
I _{OZ}	TRI-STATE Output Leakage	0 ≤ V _O ≤ 5.5V V _I = V _{IH} or V _{IL}	2.7-3.6		±5.0	μA
I _{OFF}	Power-Off Leakage Current	V _I or V _O = 5.5V	0		10	μA
I _{CC}	Quiescent Supply Current	V _I = V _{CC} or GND	2.7-3.6		20	μA
		3.6V ≤ V _I , V _O ≤ 5.5V	2.7-3.6		±20	μA
ΔI _{CC}	Increase in I _{CC} per Input	V _{IH} = V _{CC} - 0.6V	2.7-3.6		500	μA

AC Electrical Characteristics

Symbol	Parameter	$T_A = -40^{\circ}\text{C to } +85^{\circ}\text{C}$				Units
		$V_{CC} = 3.3V \pm 0.3V$		$V_{CC} = 2.7V$		
		Min	Max	Min	Max	
t_{PHL} t_{PLH}	Propagation Delay D_n to O_n	1.5 1.5	5.4 5.4	1.5 1.5	5.9 5.9	ns
t_{PHL} t_{PLH}	Propagation Delay LE to O_n	1.5 1.5	5.5 5.5	1.5 1.5	6.4 6.4	ns
t_{PZL} t_{PZH}	Output Enable Time	1.5 1.5	6.1 6.1	1.5 1.5	6.5 6.5	ns
t_{PLZ} t_{PHZ}	Output Disable Time	1.5 1.5	6.0 6.0	1.5 1.5	6.3 6.3	ns
t_S	Setup Time, D_n to LE	2.5		2.5		ns
t_H	Hold Time, D_n to LE	1.5		1.5		ns
t_W	LE Pulse Width	3.0		3.0		ns
t_{OSHL} t_{OSLH}	Output to Output Skew (Note 1)		1.0 1.0			ns

Note 1: Skew is defined as the absolute value of the difference between the actual propagation delay for any two separate outputs of the same device. The specification applies to any outputs switching in the same direction, either HIGH to LOW (t_{OSHL}) or LOW to HIGH (t_{OSLH}). Parameter guaranteed by design.

Dynamic Switching Characteristics

Symbol	Parameter	Conditions	V_{CC} (V)	$T_A = 25^{\circ}\text{C}$	Units
				Typical	
V_{OLP}	Quiet Output Dynamic Peak V_{OL}	$C_L = 50 \text{ pF}$, $V_{IH} = 3.3V$, $V_{IL} = 0V$	3.3	0.8	V
V_{OLV}	Quiet Output Dynamic Valley V_{OL}	$C_L = 50 \text{ pF}$, $V_{IH} = 3.3V$, $V_{IL} = 0V$	3.3	-0.8	V

Capacitance

Symbol	Parameter	Conditions	Typical	Units
C_{IN}	Input Capacitance	$V_{CC} = \text{Open}$, $V_I = 0V$ or V_{CC}	7	pF
C_{OUT}	Output Capacitance	$V_{CC} = 3.3V$, $V_I = 0V$ or V_{CC}	8	pF
C_{PD}	Power Dissipation Capacitance	$V_{CC} = 3.3V$, $V_I = 0V$ or V_{CC} , $F = 10 \text{ MHz}$	20	pF

74LCX16373 Ordering Information

The device number is used to form part of a simplified purchasing code where the package type and temperature range are defined as follows:

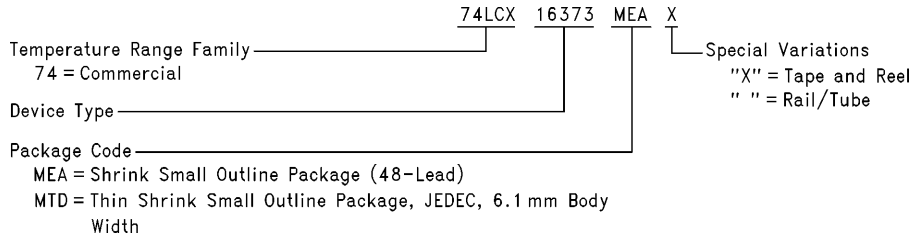

TL/F/12002-5

Physical Dimensions All dimensions are in inches (millimeters)

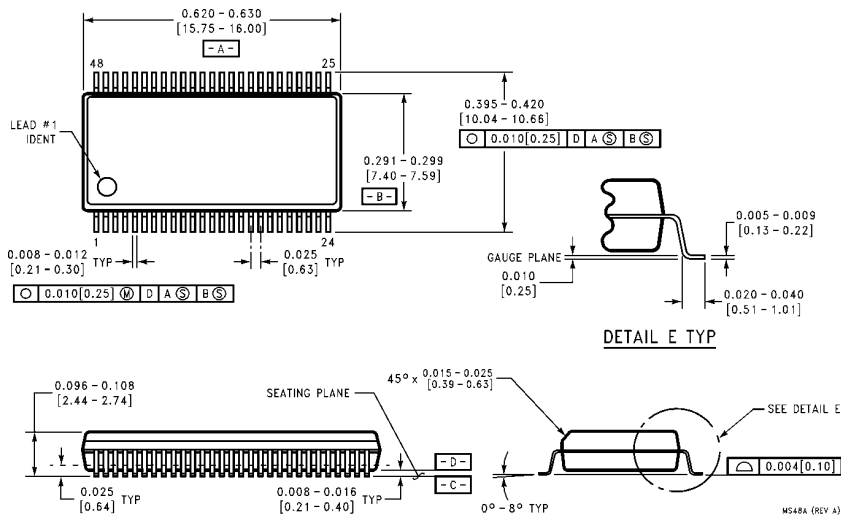

48-Lead (0.300" Wide) Shrink Small Outline Package
Order Number 74LCX16373MEA or 74LCX16373MEAX
NS Package Number MS48A

Physical Dimensions All dimensions are in millimeters (Continued)

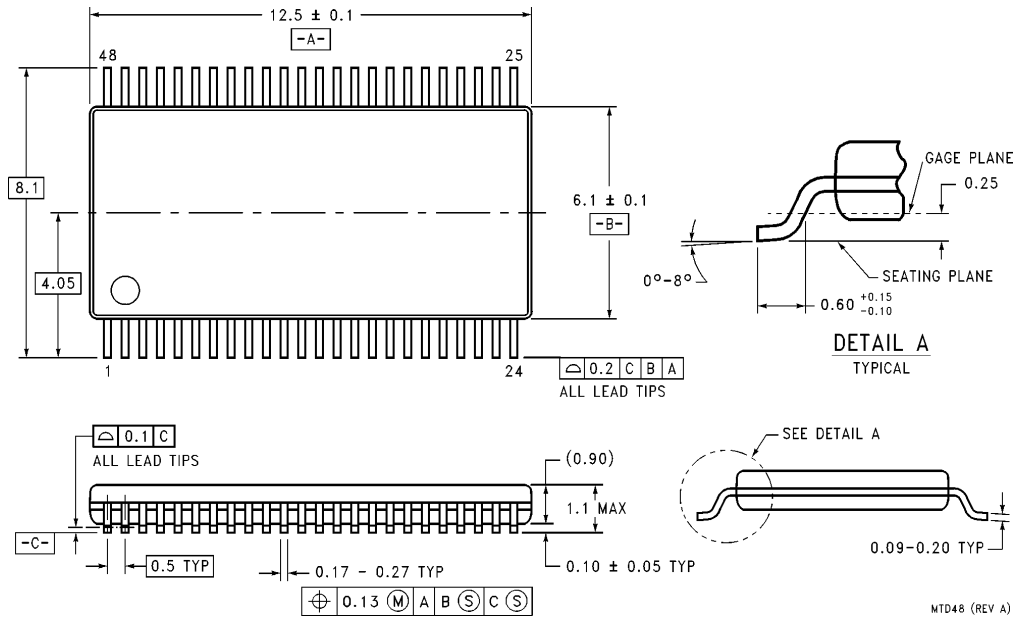

48-Lead Thin Shrink Small Outline Package, JEDEC, 6.1 mm Body Width
Order Number 74LCX16373MTD or 74LCX16373MTDX
NS Package Number MTD48

LIFE SUPPORT POLICY

NATIONAL'S PRODUCTS ARE NOT AUTHORIZED FOR USE AS CRITICAL COMPONENTS IN LIFE SUPPORT DEVICES OR SYSTEMS WITHOUT THE EXPRESS WRITTEN APPROVAL OF THE PRESIDENT OF NATIONAL SEMICONDUCTOR CORPORATION. As used herein:

1. Life support devices or systems are devices or systems which, (a) are intended for surgical implant into the body, or (b) support or sustain life, and whose failure to perform, when properly used in accordance with instructions for use provided in the labeling, can be reasonably expected to result in a significant injury to the user.
2. A critical component is any component of a life support device or system whose failure to perform can be reasonably expected to cause the failure of the life support device or system, or to affect its safety or effectiveness.

	<p>National Semiconductor Corporation Americas Tel: 1(800) 272-9959 Fax: 1(800) 737-7018 Email: support@nsc.com</p>	<p>National Semiconductor Europe Fax: +49 (0) 180-530 85 86 Email: europe.support@nsc.com Deutsch Tel: +49 (0) 180-530 85 85 English Tel: +49 (0) 180-532 78 32 Français Tel: +49 (0) 180-532 93 58 Italiano Tel: +49 (0) 180-534 16 80</p>	<p>National Semiconductor Southeast Asia Fax: (852) 2376 3901 Email: sea.support@nsc.com</p>	<p>National Semiconductor Japan Ltd. Tel: 81-3-5620-7561 Fax: 81-3-5620-6179</p>
	<p>http://www.national.com</p>			
	<p>National does not assume any responsibility for use of any circuitry described, no circuit patent licenses are implied and National reserves the right at any time without notice to change said circuitry and specifications.</p>			
	<p>MTD48 (REV A)</p>			
	<p>NS Package Number MTD48</p>			