

74LVT162244

3.3V ABT 16-Bit Buffer/Line Driver with TRI-STATE® Outputs

General Description

The LVT162244 contains sixteen non-inverting buffers with TRI-STATE outputs designed to be employed as a memory and address driver, clock driver, or bus oriented transmitter/receiver. The device is nibble controlled. Individual TRI-STATE control inputs can be shorted together for 8-bit or 16-bit operation.

The LVT 162244 is designed with equivalent 25Ω series resistance in both the High and Low states of the output. This design reduces line noise in applications such as memory address drivers, clock drivers, and bus transceivers/transmitters.

These bus buffers and line drivers are designed for low-voltage (3.3V) V_{CC} applications, but with the capability to provide a TTL interface to a 5V environment. The LVT162244 is fabricated with an advanced BiCMOS technology to achieve high speed operation similar to 5V ABT while maintaining a low power dissipation.

Features

- Input and output interface capability to systems at 5V V_{CC}
- Bus-Hold data inputs eliminate the need for external pull-up resistors to hold unused inputs
- Live insertion/extraction permitted
- Power Up/Down high impedance provides glitch-free bus loading
- Outputs include equivalent series resistance of 25Ω to make external termination resistors unnecessary and reduce overshoot and undershoot
- Available in SSOP and TSSOP
- Functionally compatible with the 74 series 162244
- Latch-up performance exceeds 500 mA

Logic Symbol

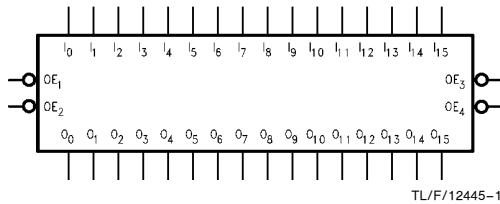

Pin Names	Description
\overline{OE}_n	Output Enable Inputs (Active Low)
I_0-I_{15}	Inputs
O_0-O_{15}	Outputs

	SSOP	TSSOP
Order Number	74LVT162244MEA 74LVT162244MEAX	74LVT162244MTD 74LVT162244MTDX
See NS Package Number	MS48A	MTD48

Connection Diagram

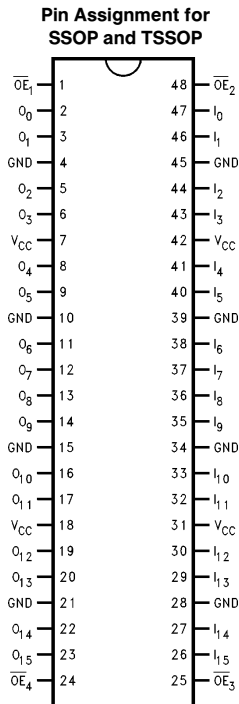

TRI-STATE® is a registered trademark of National Semiconductor Corporation.

Functional Description

The LVT162244 contains sixteen non-inverting buffers with TRI-STATE outputs. The device is nibble (4 bits) controlled with each nibble functioning identically, but independent of the other. The control pins can be shorted together to obtain full 16-bit operation.

Truth Tables

Inputs		Outputs
\overline{OE}_1	I_0-I_3	O_0-O_3
L	L	L
L	H	H
H	X	Z

Inputs		Outputs
\overline{OE}_2	I_4-I_7	O_4-O_7
L	L	L
L	H	H
H	X	Z

Inputs		Outputs
\overline{OE}_3	I_8-I_{11}	O_8-O_{11}
L	L	L
L	H	H
H	X	Z

Inputs		Outputs
\overline{OE}_4	$I_{12}-I_{15}$	$O_{12}-O_{15}$
L	L	L
L	H	H
H	X	Z

H = High Voltage Level

L = Low Voltage Level

X = Immaterial

Z = High Impedance

Logic Diagram

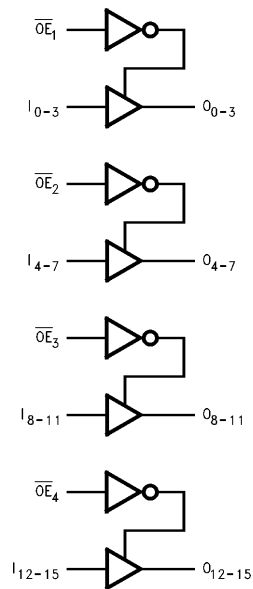

TL/F/12445-3

Absolute Maximum Ratings (Note 1)

Symbol	Parameter	Value	Conditions	Units
V _{CC}	Supply Voltage	-0.5 to +7.0		V
V _I	DC Input Voltage	-0.5 to +7.0		V
V _O	Output Voltage	-0.5 to +7.0	Output in TRI-STATE	V
		-0.5 to +7.0	Output in High or Low State (Note 2)	V
I _{IK}	DC Input Diode Current	-50	V _I < GND	mA
I _{OK}	DC Output Diode Current	-50	V _O < GND	mA
I _O	DC Output Current	64	V _O > V _{CC} Output at HIGH State	mA
		128	V _O > V _{CC} Output at LOW State	
I _{CC}	DC Supply Current per Supply Pin	±64		mA
I _{GND}	DC Ground Current per Ground Pin	±128		mA
T _{STG}	Storage Temperature	-65 to +150		°C

Note 1: The "Absolute Maximum Ratings" are those values beyond which the safety of the device cannot be guaranteed. The device should not be operated at these limits. The parametric values defined in the "Electrical Characteristics" table are not guaranteed at the Absolute Maximum Ratings. The "Recommended Operating Conditions" table will define the conditions for actual device operation.

Note 2: I_O Absolute Maximum Rating must be observed.

Recommended Operating Conditions

Symbol	Symbol	Min	Max	Units	
V _{CC}	Supply Voltage	Operating	2.7	3.6	V
		Data Retention	1.5	3.6	
V _I	Input Voltage	0	5.5	V	
V _O	Output Voltage	HIGH or LOW State	0	V _{CC}	V
		TRI-STATE	0	5.5	
I _{OH}	High-Level Output Current		-12	mA	
I _{OL}	Low-Level Output Current		12	mA	
T _A	Free Air Operating Temperature	-40	+85	°C	
Δt/ΔV	Input Edge Rate, V _{IN} = 0.8V-2.0V, V _{CC} = 3.0V	0	10	ns/V	

DC Electrical Characteristics

Symbol	Parameter	V _{CC} (V)	T _A = -40°C to +85°C			Units	Conditions	
			Min	Typ (Note 3)	Max			
V _{IK}	Input Clamp Diode Voltage	2.7			-1.2	V	I _I = -18 mA	
V _{IH}	Input HIGH Voltage	2.7-3.6	2.0			V	V _O ≤ 0.1V or V _O ≥ V _{CC} - 0.1V	
V _{IL}	Input LOW Voltage	2.7-3.6			0.8			
V _{OH}	Output HIGH Voltage	2.7-3.6	V _{CC} - 0.2			V	I _{OH} = -100 μA	
		3.0	2.0			V	I _{OH} = -12 mA	
V _{OL}	Output LOW Voltage	2.7			0.2	V	I _{OL} = 100 μA	
		3.0			0.8	V	I _{OL} = 12 mA	
I _{I(HOLD)}	Bus-Hold Input Minimum Drive	3.0	75			μA	V _I = 0.8V	
			-75				μA	V _I = 2.0V
I _{I(OD)}	Bus-Hold Input Over-Drive Current to Change State	3.0	500			μA	(Note 4)	
			-500				μA	(Note 5)
I _I	Input Current	3.6			10	μA	V _I = 5.5V	
		Control Pins	3.6			±1	μA	V _I = 0V or V _{CC}
		Data Pins	3.6			-5	μA	V _I = 0V
							1	μA
I _{OFF}	Power Off Leakage Current	0			±100	μA	0V ≤ V _I or V _O ≤ 5.5V	
I _{PU/PD} (Note 6)	Power Up/Down TRI-STATE Current	0-1.2V			±100	μA	V _O = 0.5V to V _{CC} V _I = GND or V _{CC}	
I _{OZL}	TRI-STATE Output Leakage Current	3.6			-5	μA	V _O = 0.5V	
I _{OZH}	TRI-STATE Output Leakage Current	3.6			5	μA	V _O = 3.0V	
I _{OZH} ⁺	TRI-STATE Output Leakage Current	3.6			10	μA	V _{CC} < V _O ≤ 5.5V	
I _{CCH}	Power Supply Current	3.6			0.09	mA	Outputs High	
I _{CCL}	Power Supply Current	3.6			5	mA	Outputs Low	
I _{CCZ}	Power Supply Current	3.6			0.09	mA	Outputs Disabled	
I _{CCZ} ⁺	Power Supply Current	3.6			0.09	mA	V _{CC} ≤ V _O ≤ 5.5V, Outputs Disabled	
ΔI _{CC}	Increase in Power Supply Current (Note 7)	3.6			0.2	mA	One Input at V _{CC} - 0.6V Other Inputs at V _{CC} or GND	

Note 3: All typical values are at V_{CC} = 3.3V, T_A = 25°C.

Note 4: An external driver must source at least the specified current to switch from LOW to HIGH.

Note 5: An external driver must sink at least the specified current to switch from HIGH to LOW.

Note 6: This parameter is valid for any V_{CC} between 0V and 1.2V at 25°C only.

Note 7: This is the increase in supply current for each input that is at the specified voltage level rather than V_{CC} or GND.

Dynamic Switching Characteristics (Note 8)

Symbol	Parameter	V _{CC} (V)	T _A = 25°C			Units	Conditions C _L = 50 pF, R _L = 500Ω
			Min	Typ	Max		
V _{OLP}	Quiet Output Maximum Dynamic V _{OL}	3.3	0.8			V	(Note 9)
V _{OLV}	Quiet Output Minimum Dynamic V _{OL}	3.3	-0.8			V	(Note 9)

Note 8: Characterized in SOIC package. Guaranteed parameter, but not tested.

Note 9: Max number of outputs defined as (n). n - 1 data inputs are driven 0V to 3V. Output under test held LOW.

AC Electrical Characteristics

Symbol	Parameter	T _A = -40°C to +85°C C _L = 50 pF, R _L = 500Ω					Units
		V _{CC} = 3.3V ± 0.3V			V _{CC} = 2.7V		
		Min	Typ (Note 3)	Max	Min	Max	
t _{PLH} t _{PHL}	Propagation Delay Data to Output	1.0 1.0		4.9 5.0	1.0 1.0	5.8 6.1	ns
t _{PZH} t _{PZL}	Output Enable Time	1.0 1.0		6.4 5.6	1.0 1.0	7.1 7.3	ns
t _{PHZ} t _{PLZ}	Output Disable Time	1.8 1.8		6.6 5.8	1.8 1.8	7.3 6.5	ns
t _{OSSL} t _{OSLH}	Output to Output Skew (Note 10)			1.0			ns

Note 3: All typical values are at V_{CC} = 3.3V, T_A = 25°C.

Note 10: Skew is defined as the absolute value of the difference between the actual propagation delay for any two separate outputs of the same device. The specification applies to any outputs switching in the same direction, either HIGH to LOW (t_{OSSL}) or LOW to HIGH (t_{OSLH}). Parameter guaranteed by design.

Capacitance (Note 11)

Symbol	Parameter	Min	Typ	Max	Units	Conditions
C _{IN}	Input Capacitance		4		pF	V _{CC} = 0V, V _I = 0V or V _{CC}
C _{OUT}	Output Capacitance		10		pF	V _{CC} = 3.0V, V _O = 0V or V _{CC}

Note 11: Capacitance is measured at frequency f = 1 MHz, per MIL-STD-883B, Method 3012.

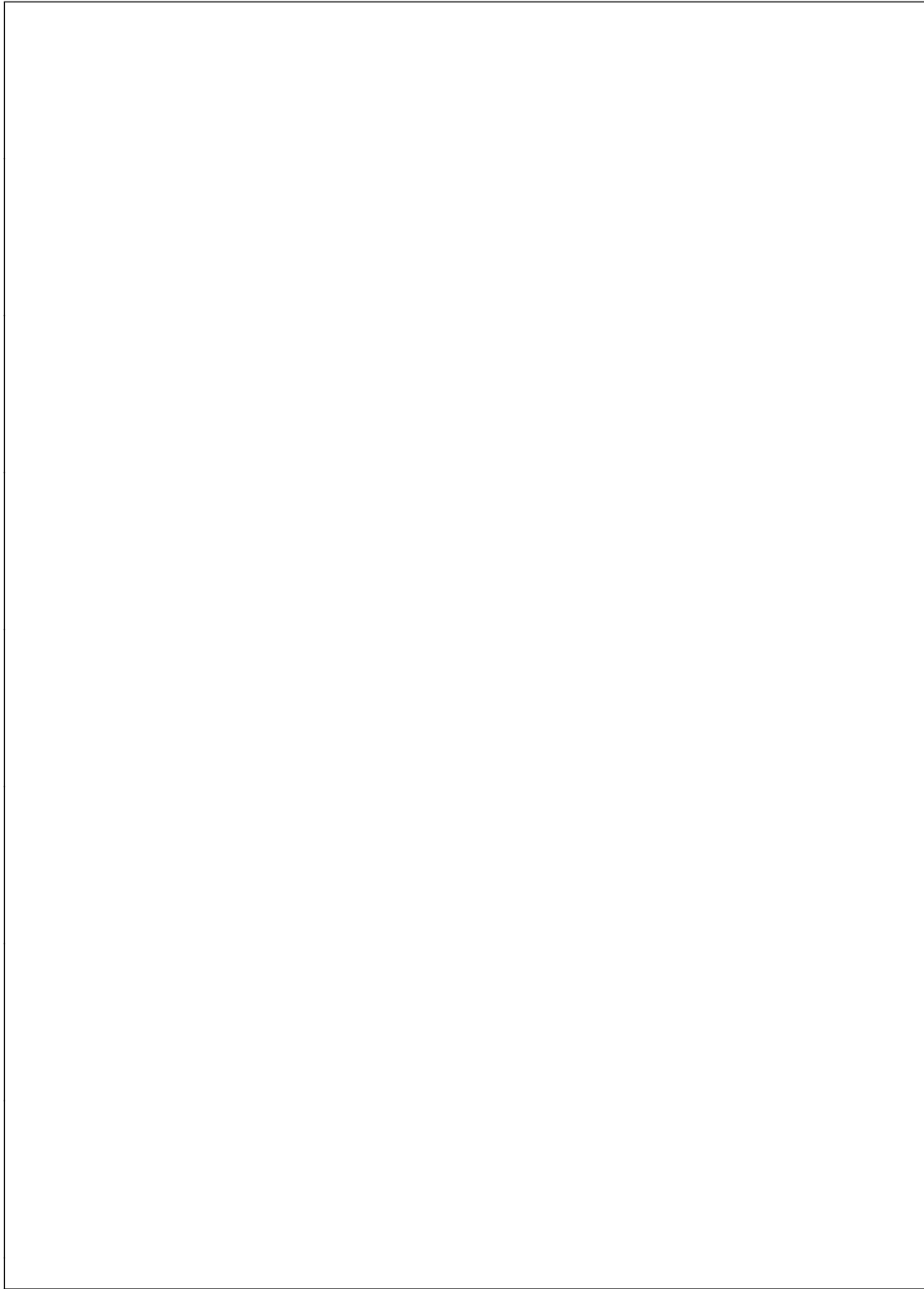

74LVT162244 Ordering Information

The device number is used to form part of a simplified purchasing code where the package type and temperature range are defined as follows:

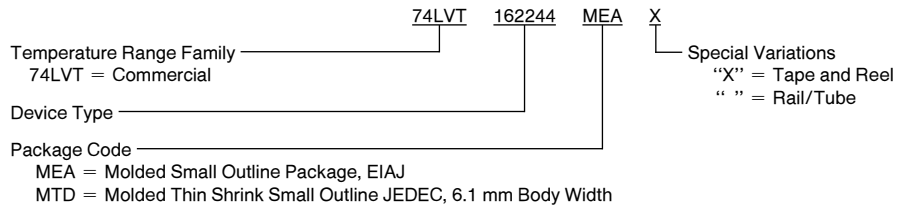

Physical Dimensions inches (millimeters) unless otherwise noted

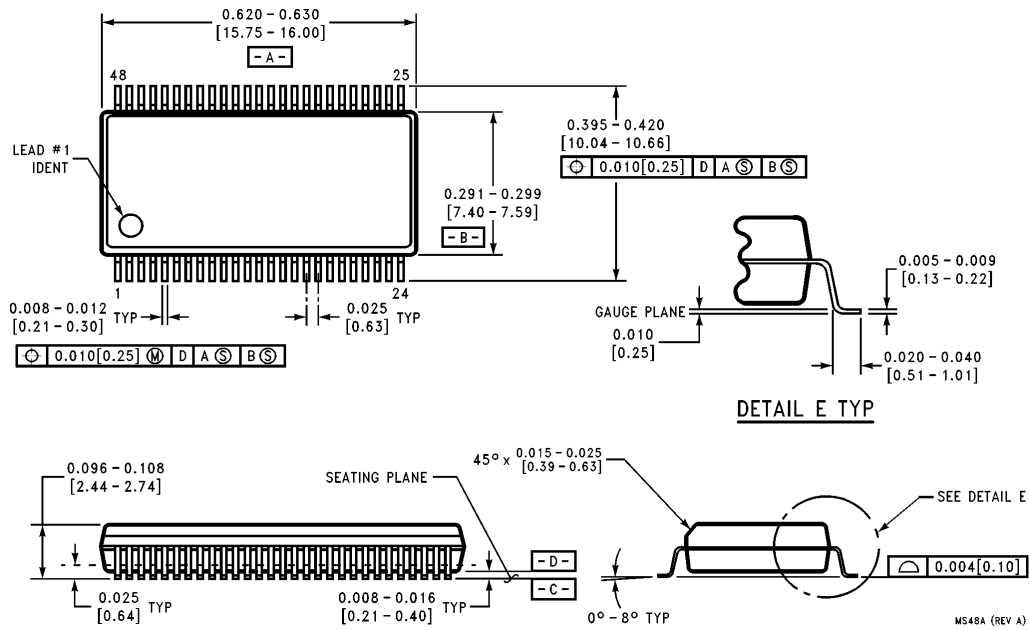

48-Lead Molded Shrink Small Outline Package, EIAJ
Order Number 74LVT162244MEA or 74LVT162244MEAX
NS Package Number MS48A

Physical Dimensions millimeters (Continued)

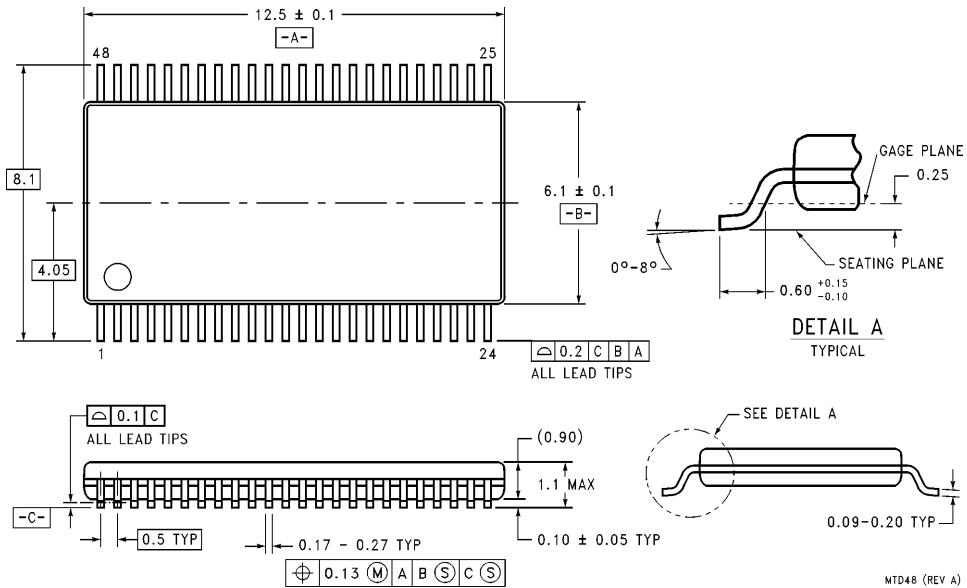

48-Lead Molded Thin Shrink Small Outline Package, JEDEC, 6.1 mm Body Width
Order Number 74LVT162244MTD or 74LVT162244MTDX
NS Package Number MTD48

LIFE SUPPORT POLICY

NATIONAL'S PRODUCTS ARE NOT AUTHORIZED FOR USE AS CRITICAL COMPONENTS IN LIFE SUPPORT DEVICES OR SYSTEMS WITHOUT THE EXPRESS WRITTEN APPROVAL OF THE PRESIDENT OF NATIONAL SEMICONDUCTOR CORPORATION. As used herein:

1. Life support devices or systems are devices or systems which, (a) are intended for surgical implant into the body, or (b) support or sustain life, and whose failure to perform, when properly used in accordance with instructions for use provided in the labeling, can be reasonably expected to result in a significant injury to the user.
2. A critical component is any component of a life support device or system whose failure to perform can be reasonably expected to cause the failure of the life support device or system, or to affect its safety or effectiveness.

	National Semiconductor Corporation	National Semiconductor Europe	National Semiconductor Southeast Asia	National Semiconductor Japan Ltd.
	Americas			
	Tel: 1(800) 272-9959	Fax: +49 (0) 180-530 85 86	Fax: (852) 2376 3901	Tel: 81-3-5620-7561
	Fax: 1(800) 737-7018	Email: europe.support@nsc.com	Email: sea.support@nsc.com	Fax: 81-3-5620-6179
	Email: support@nsc.com	Deutsch Tel: +49 (0) 180-530 85 85		
	English Tel: +49 (0) 180-532 78 32			
	Français Tel: +49 (0) 180-532 93 58			
	Italiano Tel: +49 (0) 180-534 16 80			
http://www.national.com				

National does not assume any responsibility for use of any circuitry described, no circuit patent licenses are implied and National reserves the right at any time without notice to change said circuitry and specifications.