

CD4019BM/CD4019BC Quad AND-OR Select Gate

General Description

The CD4019BM/CD4019BC is a complementary MOS quad AND-OR select gate. Low power and high noise margin over a wide voltage range is possible through implementation of N- and P-channel enhancement mode transistors. These complementary MOS (CMOS) transistors provide the building blocks for the 4 "AND-OR select" gate configurations, each consisting of two 2-input AND gates driving a single 2-input OR gate. Selection is accomplished by control bits K_A and K_B . All inputs are protected against static discharge damage.

Features

- Wide supply voltage range 3.0V to 15V
- High noise immunity 0.45 V_{DD} (typ.)
- Low power TTL compatibility Fan out of 2 driving 74L or 1 driving 74LS

Applications

- AND-OR select gating
- Shift-right/shift-left registers
- True/complement selection
- AND/OR/EXCLUSIVE-OR selection

Connection and Schematic Diagrams

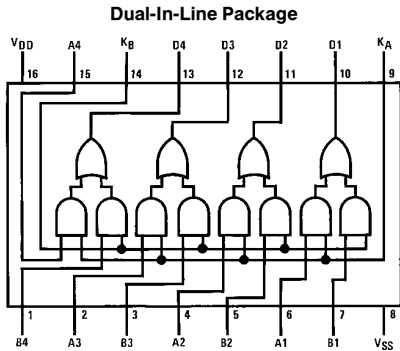

Order Number CD4019B

Top View

TL/F/5952-1

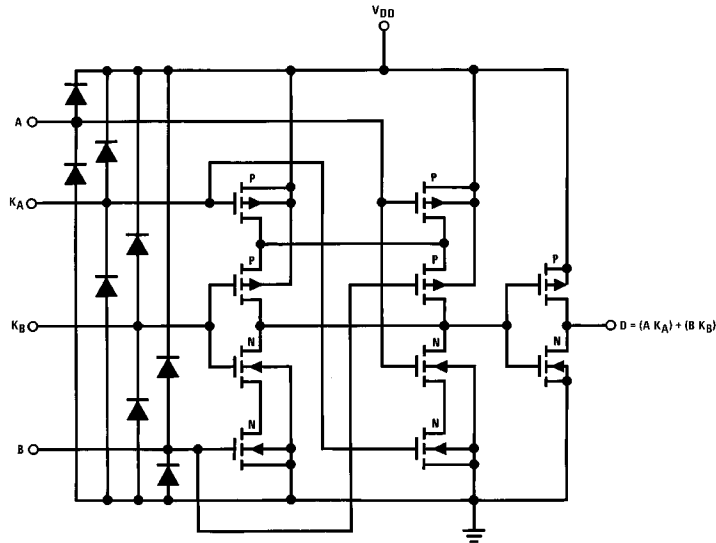

Schematic diagram for 1 of 4 identical stages

TL/F/5952-2

Absolute Maximum Ratings (Notes 1 & 2)

If Military/Aerospace specified devices are required, please contact the National Semiconductor Sales Office/Distributors for availability and specifications.

Supply Voltage (V_{DD})	-0.5V to +18V
Input Voltage (V_{IN})	-0.5V to V_{DD} + 0.5V
Storage Temperature Range (T_S)	-65°C to +150°C
Power Dissipation (P_D)	
Dual-In-Line	700 mW
Small Outline	500 mW
Lead Temperature (T_L)	
(Soldering, 10 seconds)	260°C

Recommended Operation

Conditions (Note 2)

DC Supply Voltage (V_{DD})	+3V to +15V
Input Voltage (V_{IN})	0V to V_{DD} V
Operating Temperature Range (T_A)	
CD4019BM	-55°C to +125°C
CD4019BC	-40°C to +85°C

DC Electrical Characteristics CD4019BM (Note 2)

Symbol	Parameter	Conditions	-55°C		+25°C			+125°C		Units
			Min	Max	Min	Typ	Max	Min	Max	
I_{DD}	Quiescent Device Current	$V_{DD} = 5V$		0.25		0.03	0.25		7.5	μA
		$V_{DD} = 10V$		0.5		0.05	0.5		15	μA
		$V_{DD} = 15V$		1.0		0.07	1.0		30	μA
V_{OL}	Low Level Output Voltage	$ I_O < 1 \mu A$								
		$V_{DD} = 5V$		0.05		0	0.05		0.05	V
		$V_{DD} = 10V$		0.05		0	0.05		0.05	V
		$V_{DD} = 15V$		0.05		0	0.05		0.05	V
V_{OH}	High Level Output Voltage	$ I_O < 1 \mu A$								
		$V_{DD} = 5V$	4.95		4.95	5		4.95		V
		$V_{DD} = 10V$	9.95		9.95	10		9.95		V
		$V_{DD} = 15V$	14.95		14.95	15		14.95		V
V_{IL}	Low Level Input Voltage	$V_{DD} = 5V, V_O = 0.5V$ or 4.5V		1.5		2	1.5		1.5	V
		$V_{DD} = 10V, V_O = 1.0V$ or 9.0V		3.0		4	3.0		3.0	V
		$V_{DD} = 15V, V_O = 1.5V$ or 13.5V		4.0		6	4.0		4.0	V
V_{IH}	High Level Input Voltage	$V_{DD} = 5V, V_O = 0.5V$ or 4.5V	3.5		3.5	3		3.5		V
		$V_{DD} = 10V, V_O = 1.0V$ or 9.0V	7.0		7.0	6		7.0		V
		$V_{DD} = 15V, V_O = 1.5V$ or 13.5V	11.0		11.0	9		11.0		V
I_{OL}	Low Level Output Current (Note 3)	$V_{DD} = 5V, V_O = 0.4V$	0.64		0.51	1		0.36		mA
		$V_{DD} = 10V, V_O = 0.5V$	1.6		1.3	2.5		0.9		mA
		$V_{DD} = 15V, V_O = 1.5V$	4.2		3.4	10		2.4		mA
I_{OH}	High Level Output Current (Note 3)	$V_{DD} = 5V, V_O = 4.6V$	-0.25		-0.2	-0.4		-0.14		mA
		$V_{DD} = 10V, V_O = 9.5V$	-0.62		-0.5	-1.0		-0.35		mA
		$V_{DD} = 15V, V_O = 13.5V$	-1.8		-1.5	-3.0		-1.1		mA
I_{IN}	Input Current	$V_{DD} = 15V, V_{IN} = 0V$		-0.10		-10^{-5}	-0.10		-1.0	μA
		$V_{DD} = 15V, V_{IN} = 15V$		0.10		10^{-5}	0.10		1.0	μA

Note 1: "Absolute Maximum Ratings" are those values beyond which the safety of the device cannot be guaranteed; they are not meant to imply that the devices should be operated at these limits. The tables of "Recommended Operating Conditions" and "Electrical Characteristics" provide conditions for actual device operation.

Note 2: $V_{SS} = 0V$ unless otherwise specified.

Note 3: I_{OH} and I_{OL} are tested one output at a time.

DC Electrical Characteristics CD4019BC (Note 2)

Symbol	Parameter	Conditions	-55°C		+25°C			+125°C		Units
			Min	Max	Min	Typ	Max	Min	Max	
I _{DD}	Quiescent Device Current	V _{DD} = 5V		1		0.03	1		7.5	μA
		V _{DD} = 10V		2		0.05	2		15	μA
		V _{DD} = 15V		4		0.07	4		30	μA
V _{OL}	Low Level Output Voltage	I _O < 1 μA								
		V _{DD} = 5V		0.05		0	0.05		0.05	V
		V _{DD} = 10V		0.05		0	0.05		0.05	V
		V _{DD} = 15V		0.05		0	0.05		0.05	V
V _{OH}	High Level Output Voltage	I _O < 1 μA								
		V _{DD} = 5V	4.95		4.95	5		4.95		V
		V _{DD} = 10V	9.95		9.95	10		9.95		V
		V _{DD} = 15V	14.95		14.95	15		14.95		V
V _{IL}	Low Level Input Voltage	V _{DD} = 5V, V _O = 0.5V or 4.5V		1.5		2	1.5		1.5	V
		V _{DD} = 10V, V _O = 1.0V or 9.0V		3.0		4	3.0		3.0	V
		V _{DD} = 15V, V _O = 1.5V or 13.5V		4.0		6	4.0		4.0	V
		V _{DD} = 5V, V _O = 0.5V or 4.5V	3.5		3.5	3		3.5		V
V _{IH}	High Level Input Voltage	V _{DD} = 10V, V _O = 1.0V or 9.0V	7.0		7.0	6		7.0		V
		V _{DD} = 15V, V _O = 1.5V or 13.5V	11.0		11.0	9		11.0		V
		V _{DD} = 5V, V _O = 0.4V	0.52		0.44	1		0.36		mA
		V _{DD} = 10V, V _O = 0.5V	1.3		1.1	2.5		0.9		mA
I _{OL}	Low Level Output Current (Note 3)	V _{DD} = 15V, V _O = 1.5V	3.6		3.0	10		2.4		mA
		V _{DD} = 5V, V _O = 4.6V	-0.2		-0.16	-0.4		-0.12		mA
		V _{DD} = 10V, V _O = 9.5V	-0.5		-0.4	-1.0		-0.3		mA
I _{OH}	High Level Output Current (Note 3)	V _{DD} = 15V, V _O = 13.5V	-1.4		-1.2	-3.0		-1.0		mA
		V _{DD} = 15V, V _{IN} = 0V		-0.30		-10 ⁻⁵	-0.30		-1.0	μA
		V _{DD} = 15V, V _{IN} = 15V		0.30		10 ⁻⁵	0.30		1.0	μA

Note 1: "Absolute Maximum Ratings" are those values beyond which the safety of the device cannot be guaranteed; they are not meant to imply that the devices should be operated at these limits. The tables of "Recommended Operating Conditions" and "Electrical Characteristics" provide conditions for actual device operation.

Note 2: V_{SS} = 0V unless otherwise specified.

Note 3: I_{OH} and I_{OL} are tested one output at a time.

AC Electrical Characteristics* T_A = 25°C, C_L = 50 pF, R_L = 200k, unless otherwise specified

Symbol	Parameter	Conditions	Min	Typ	Max	Units
t _{PHL} , t _{PLH}	Propagation Delay, Input to Output	V _{DD} = 5V		100	300	ns
		V _{DD} = 10V		50	120	ns
		V _{DD} = 15V		45	100	ns
t _{THL}	High-to-Low Level Transition Time	V _{DD} = 5V		100	200	ns
		V _{DD} = 10V		50	100	ns
		V _{DD} = 15V		40	80	ns
t _{TLH}	Low-to-High Level Transition Time	V _{DD} = 5V		150	300	ns
		V _{DD} = 10V		70	140	ns
		V _{DD} = 15V		50	100	ns
C _{IN}	Input Capacitance	All A and B Inputs		5	7.5	pF
		K _A and K _B Inputs		10	15	pF

*AC Parameters are guaranteed by DC correlated testing.

Physical Dimensions inches (millimeters) (Continued)

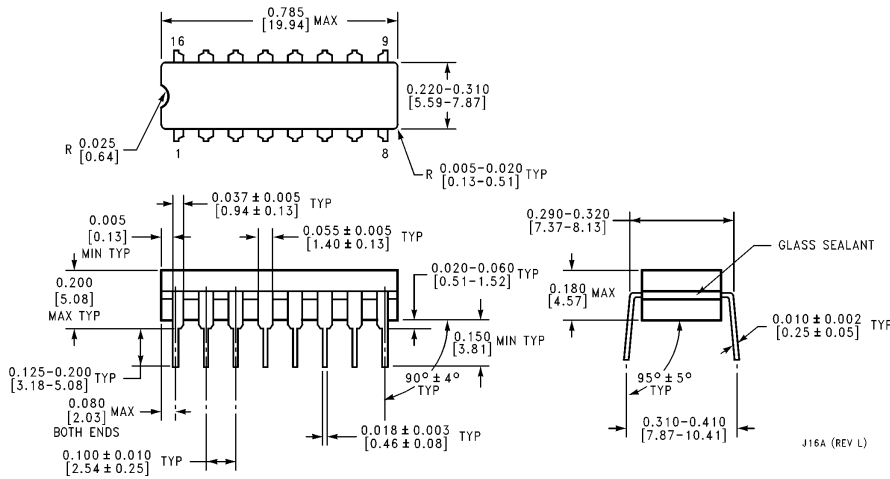

Ceramic Dual-In-Line Package (J)
Order Number CD4019BMJ or CD4019BCJ
NS Package Number J16A

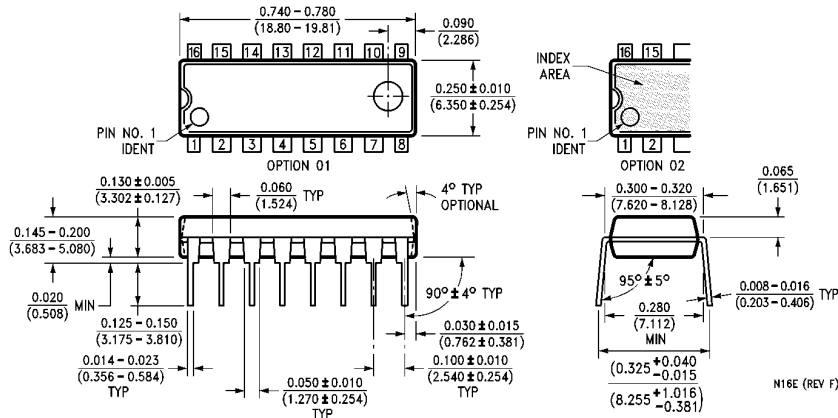

Molded Dual-In-Line Package (N)
Order Number CD4019BMN or CD4019BCN
NS Package Number N16E

LIFE SUPPORT POLICY

NATIONAL'S PRODUCTS ARE NOT AUTHORIZED FOR USE AS CRITICAL COMPONENTS IN LIFE SUPPORT DEVICES OR SYSTEMS WITHOUT THE EXPRESS WRITTEN APPROVAL OF THE PRESIDENT OF NATIONAL SEMICONDUCTOR CORPORATION. As used herein:

1. Life support devices or systems are devices or systems which, (a) are intended for surgical implant into the body, or (b) support or sustain life, and whose failure to perform, when properly used in accordance with instructions for use provided in the labeling, can be reasonably expected to result in a significant injury to the user.
2. A critical component is any component of a life support device or system whose failure to perform can be reasonably expected to cause the failure of the life support device or system, or to affect its safety or effectiveness.



National Semiconductor Corporation
 1111 West Bardin Road
 Arlington, TX 76017
 Tel: (800) 272-9959
 Fax: (800) 737-7018

National Semiconductor Europe
 Fax: (+49) 0-180-530 85 86
 Email: cnjwge@tevm2.nsc.com
 Deutsch Tel: (+49) 0-180-530 85 85
 English Tel: (+49) 0-180-532 78 32
 Français Tel: (+49) 0-180-532 93 58
 Italiano Tel: (+49) 0-180-534 16 80

National Semiconductor Hong Kong Ltd.
 19th Floor, Straight Block,
 Ocean Centre, 5 Canton Rd.
 Tsimshatsui, Kowloon
 Hong Kong
 Tel: (852) 2737-1600
 Fax: (852) 2736-9960

National Semiconductor Japan Ltd.
 Tel: 81-043-299-2309
 Fax: 81-043-299-2408

National does not assume any responsibility for use of any circuitry described, no circuit patent licenses are implied and National reserves the right at any time without notice to change said circuitry and specifications.