

Comlinear CLC411 High-Speed Video Op Amp with Disable

General Description

The Comlinear CLC411 combines a state-of-the-art complementary bipolar process with Comlinear's patented current-feedback architecture to provide a very high-speed op amp operating from $\pm 15V$ supplies. Drawing only 11mA quiescent current, the CLC411 provides a 200MHz small signal bandwidth and a 2300V/ μs slew rate while delivering a continuous 70mA current output with $\pm 4.5V$ output swing. The CLC411's high-speed performance includes a 15ns settling time to 0.1% (2V step) and a 2.3ns rise and fall time (6V step).

The CLC411 is designed to meet the requirements of professional broadcast video systems including composite video and high definition television. The CLC411 exceeds the HDTV standard for gain flatness to 30MHz with its $\pm 0.05dB$ flat frequency response and exceeds composite video standards with its very low differential gain and phase errors of 0.02%, 0.03°. The CLC411 is the op amp of choice for all video systems requiring upward compatibility from NTSC and PAL to HDTV.

The CLC411 features a very fast disable/enable (10ns/55ns) allowing the multiplexing of high-speed signals onto an analog bus through the common output connections of multiple CLC411's. Using the same signal source to drive disable/enable pins is easy since "break-before-make" is guaranteed.

The CLC411 is available in several versions:

| | | |
|-----------|-----------------|---------------------------------------|
| CLC411AJP | -40°C to +85°C | 8-pin plastic DIP |
| CLC411AJE | -40°C to +85°C | 8-pin plastic SOIC |
| CLC411A8B | -55°C to +125°C | 8-pin hermetic Cerdip, MIL-STD-883 |
| CLC411ALC | -40°C to +85°C | dice |
| CLC411AMC | -55°C to +125°C | dice, MIL-STD-883, Level B |

DESC SMD number: 5962-94566

Features

- 200MHz small signal bandwidth ($1V_{pp}$)
- $\pm 0.05dB$ gain flatness to 30MHz
- 0.02%, 0.03° differential gain, phase
- 2300V/ μs slew rate
- 10ns disable to high-impedance output
- 70mA continuous output current
- $\pm 4.5V$ output swing into 100 Ω load
- $\pm 4.0V$ input voltage range

Applications

- HDTV amplifier
- Video line driver
- High-speed analog bus driver
- Video signal multiplexer
- DAC output buffer

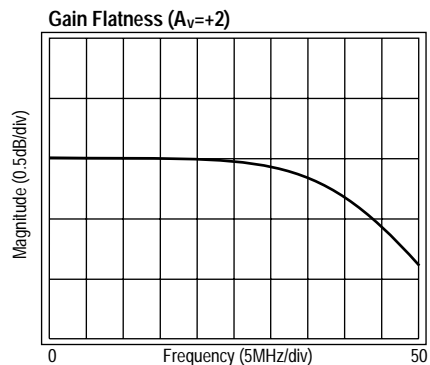

Recommended Inverting Gain Configuration

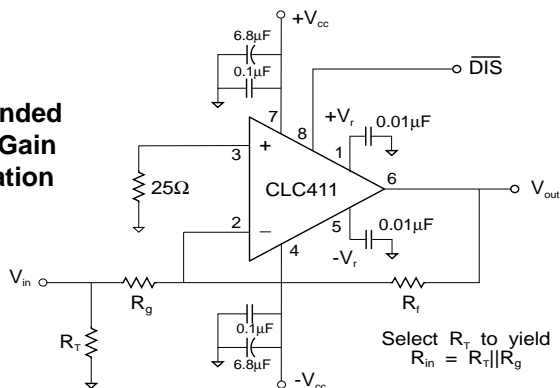

Pinout DIP & SOIC

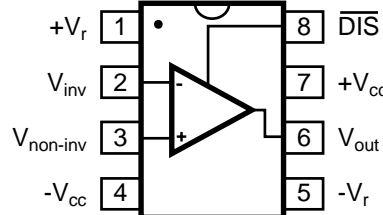

CLC411 Electrical Characteristics ($A_V = +2$; $V_{CC} = \pm 15V$; $R_L = 100\Omega$; $R_i = 301\Omega$, unless noted)

| PARAMETERS | CONDITIONS | TYP | MIN/MAX RATINGS | | | UNITS | SYMBOL |
|---|-----------------------------|-----------|-----------------|-----------|-----------|-----------------------|--------|
| | | | -40°C | +25°C | +85°C | | |
| Ambient Temperature | CLC411 AJ/AI | +25°C | -40°C | +25°C | +85°C | | |
| Ambient Temperature | CLC411 A8/AM/AL | +25°C | -55°C | +25°C | +125°C | | |
| FREQUENCY DOMAIN RESPONSE | | | | | | | |
| +3dB bandwidth | $V_{out} < 1V_{pp}$ | 200 | 150 | 150 | 110 | MHz | SSBW |
| | $V_{out} < 6V_{pp}$ | 75 | 50 | 50 | 40 | MHz | LSBW |
| gain flatness | $V_{out} < 1V_{pp}$ | | | | | | |
| $t_{peaking}$ | DC to 30MHz | 0.05 | 0.2 | 0.2 | 0.3 | dB | GFPL |
| $t_{rolloff}$ | DC to 30MHz | 0.05 | 0.2 | 0.2 | 0.4 | dB | GFRL |
| $t_{peaking}$ | DC to 200MHz | 0.1 | 0.6 | 0.5 | 0.6 | dB | GFPH |
| $t_{rolloff}$ | DC to 60MHz | 0.2 | 0.7 | 0.4 | 0.7 | dB | GFRH |
| linear phase deviation | DC to 60MHz | 0.3 | 1.0 | 1.0 | 1.0 | ° | LPD |
| differential gain | 4.43MHz, $R_L = 150\Omega$ | 0.02 | | | | % | DG |
| differential phase | 4.43MHz, $R_L = 150\Omega$ | 0.03 | | | | ° | DP |
| TIME DOMAIN RESPONSE | | | | | | | |
| rise and fall time | 6V step | 2.3 | | | | ns | TR |
| settling time to 0.1% | 2V step | 15 | 23 | 18 | 23 | ns | TS |
| overshoot | 2V step | 5 | 15 | 10 | 15 | % | OS |
| slew rate | 6V step | 2300 | | | | V/ μ s | SR |
| DISTORTION AND NOISE RESPONSE (note 1) | | | | | | | |
| $t_{2^{ND}}$ harmonic distortion | $2V_{pp}$, 20MHz | -48 | -35 | -35 | -35 | dBc | HD2 |
| $t_{3^{RD}}$ harmonic distortion | $2V_{pp}$, 20MHz | -52 | -42 | -42 | -35 | dBc | HD3 |
| equivalent noise input voltage | >1MHz | 2.5 | | | | nV/ \sqrt{Hz} | VN |
| inverting current | >1MHz | 12.9 | | | | pA/ \sqrt{Hz} | ICI |
| non-inverting current | >1MHz | 6.3 | | | | pA/ \sqrt{Hz} | ICN |
| noise floor | >1MHz | -157 | | | | dBm _{1Hz} | SNF |
| integrated noise | 1MHz to 200MHz | 45 | | | | μ V | INV |
| STATIC DC PERFORMANCE | | | | | | | |
| *input offset voltage | | ± 2 | ± 13 | ± 9.0 | ± 14 | mV | VIO |
| average temperature coefficient | | +30 | ± 50 | — | ± 50 | μ V/ $^{\circ}$ C | DVIO |
| *input bias current | non-inverting | 12 | 65 | 30 | ± 20 | μ A | IBN |
| average temperature coefficient | | ± 200 | ± 400 | — | ± 250 | nA/ $^{\circ}$ C | DIBN |
| *input bias current | inverting | ± 12 | ± 40 | ± 30 | ± 30 | μ A | IBI |
| average temperature coefficient | | ± 50 | ± 200 | — | ± 150 | nA/ $^{\circ}$ C | DIBI |
| t_{power} supply rejection ratio | | 56 | 48 | 50 | 48 | dB | PSRR |
| common mode rejection ratio | | 52 | 44 | 46 | 44 | dB | CMRR |
| *supply current | no load | 11 | 14 | 12 | 12 | mA | ICC |
| supply current | disabled | 2.5 | 4.5 | 3.5 | 4.5 | mA | ICCD |
| DISABLE/ENABLE PERFORMANCE (note 2) | | | | | | | |
| disable time | to >50dB attenuation @10MHz | 10 | 30 | 30 | 60 | ns | TOFF |
| enable time | | 55 | | | | ns | TON |
| DIS voltage | pin 8 | | | | | | |
| to disable | | 4.5 | <3.0 | <3.0 | <3.0 | V | VDIS |
| to enable | | 5.5 | >7.0 | >6.5 | >6.5 | V | VEN |
| off isolation | at 10MHz | 59 | 55 | 55 | 55 | dB | OSD |
| MISCELLANEOUS PERFORMANCE | | | | | | | |
| non-inverting input resistance | | 1000 | 250 | 750 | 1000 | k Ω | RIN |
| non-inverting input capacitance | | 2.0 | 3.0 | 3.0 | 3.0 | pF | CIN |
| output voltage range | no load | ± 6.0 | | ± 4.5 | | V | VO |
| output voltage range | $R_L = 100\Omega$ | ± 4.5 | | ± 4.0 | | V | VOL |
| common mode input range | | ± 4.0 | | ± 3.5 | | V | CMIR |
| output current | | 70 | 30 | 50 | 40 | mA | IO |

Min/max ratings are based on product characterization and simulation. Individual parameters are tested as noted. Outgoing quality levels are determined from tested parameters.

Absolute Maximum Ratings

| | |
|-------------------------------------|-----------------|
| V_{CC} | $\pm 18V$ |
| I_{out} | 125mA |
| common-mode input voltage | $\pm V_{CC}$ |
| differential input voltage | $\pm 15V$ |
| maximum junction temperature | +175°C |
| operating temperature range | |
| AJ/AI | -40°C to +85°C |
| A8/AM/AL: | -55°C to +125°C |
| storage temperature range | -65°C to +150°C |
| lead temperature (soldering 10 sec) | +300°C |

Miscellaneous Ratings

Recommended gain range ± 1 to $\pm 10V/V$

Notes:

- * AJ, AI : 100% tested at +25°C, sample at +85°C.
- † AJ : Sample tested at +25°C.
- † AI : 100% tested at +25°C.
- * A8 : 100% tested at +25°C, -55°C, +125°C.
- † A8 : 100% tested at +25°C, sample at -55°C, +125°C
- * AL, AM : 100% wafer probed +25°C to +25°C min/max specs.

note 1 : Specifications guaranteed using 0.01 μ F bypass capacitors on pins 1 & 5.

note 2 : Break before make is guaranteed.

CLC411 Typical Performance ($T_A=+25^\circ\text{C}$, $A_V=+2$, $V_{CC}=\pm 15\text{V}$, $R_L=100\Omega$, $R_I=301\Omega$, unless noted)

Non-Inverting Frequency Response

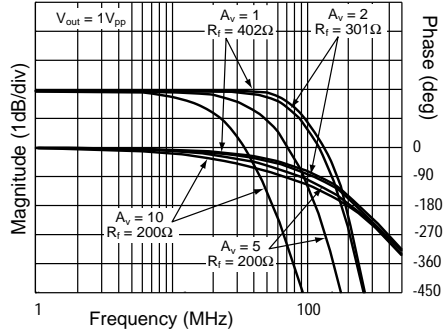

Inverting Frequency Response

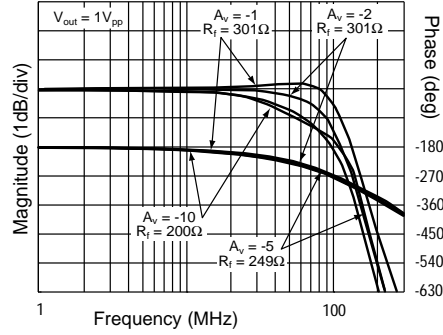

Non-Inverting Frequency Response vs. Load

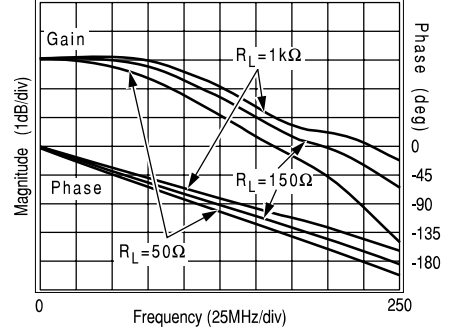

Pulse Response

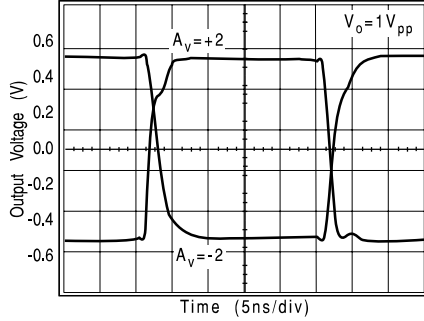

PSRR, CMRR, and Closed Loop R_o

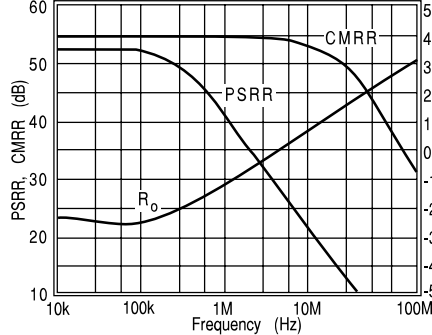

2-Tone, 3rd Order Intermodulation Intercept

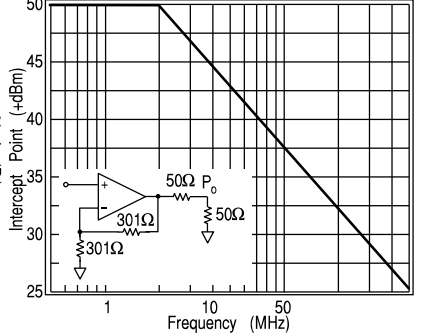

Equivalent Input Noise

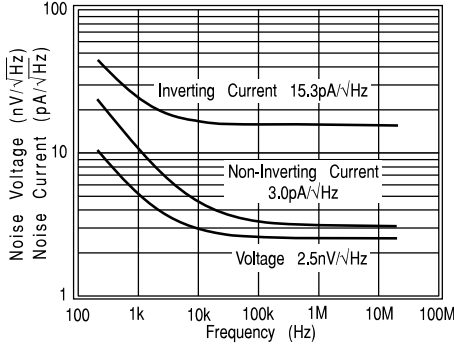

2nd and 3rd Harmonic Distortion

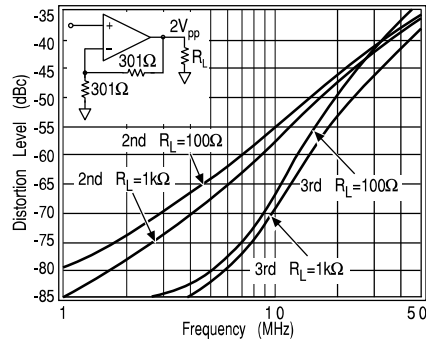

I_{BI} , I_{BN} , V_{OS} vs. Temperature

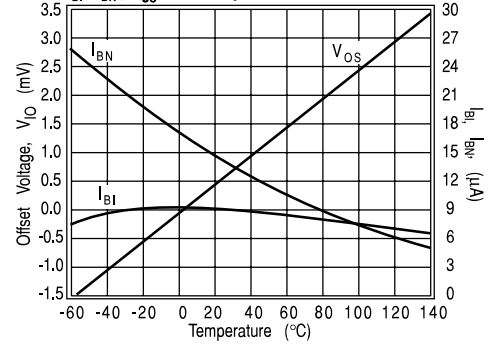

Short Term Settling Time

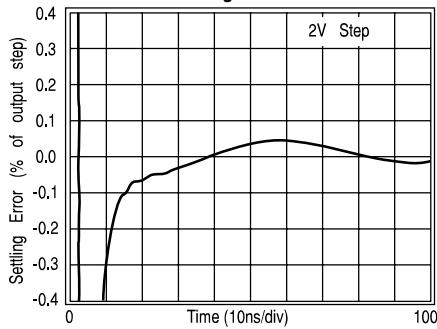

Differential Gain and Phase (4.43 MHz)

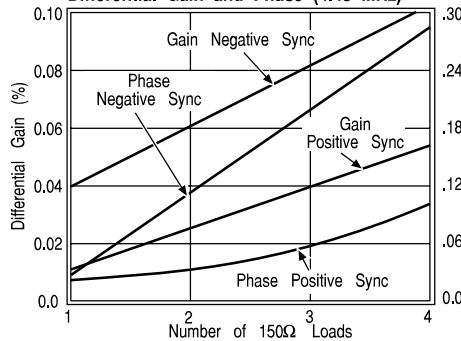

Gain Flatness and Linear Phase Deviation

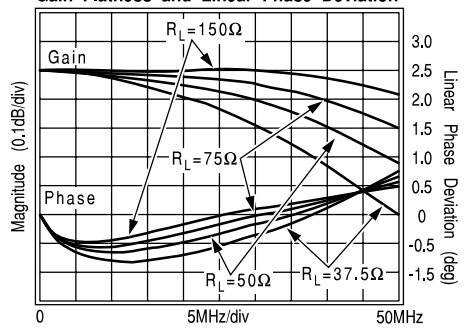

Enable/Disable Response

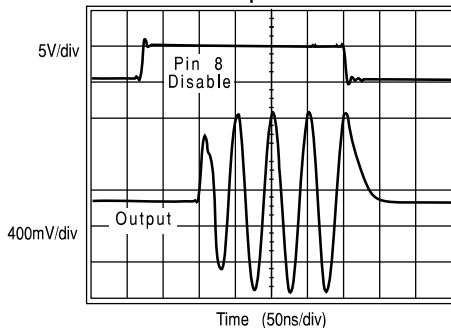

Recommended R_s vs. Capacitive Loads

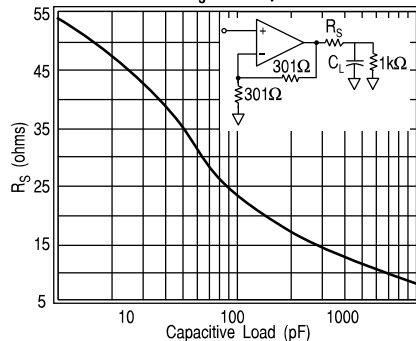

Open-Loop Transimpedance Gain, $Z(s)$

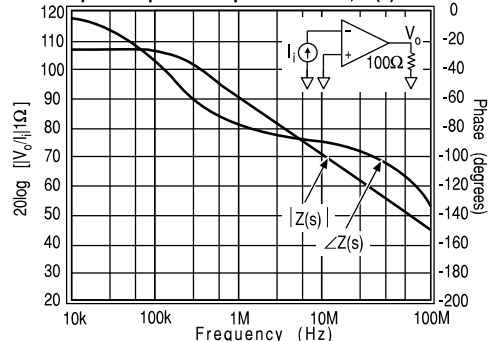

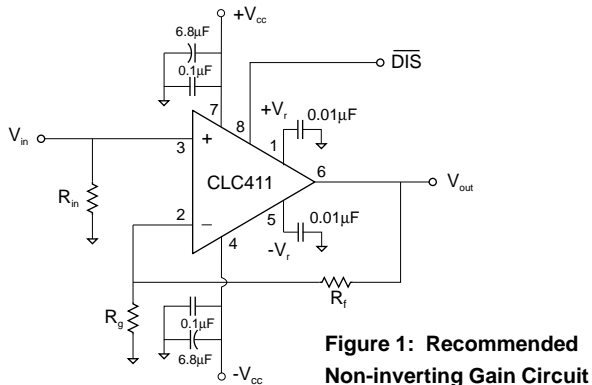

Figure 1: Recommended Non-inverting Gain Circuit

Description

The CLC411 is a high-speed current-feedback operational amplifier which operates from $\pm 15V$ power supplies. The external supplies ($\pm V_{CC}$) are regulated to lower voltages internally. The amplifier itself sees approximately $\pm 6.5V$ rails. Thus the device yields performance comparable to Comlinear’s $\pm 5V$ devices, but with higher supply voltages. There is no degradation in rated specifications when the CLC411 is operated from $\pm 12V$. A slight reduction in bandwidth will be observed with $\pm 10V$ supplies. Operation at less than $\pm 10V$ is not recommended.

A block diagram of the amplifier and regulator topology is shown in Figure 2, “CLC411 Equivalent Circuit.” The regulators derive their reference voltage from an internal floating zener voltage source. External control of the zener reference pins can be used to level-shift amplifier operation which is discussed in detail in the section entitled “Extending Input/Output Range with V_r .”

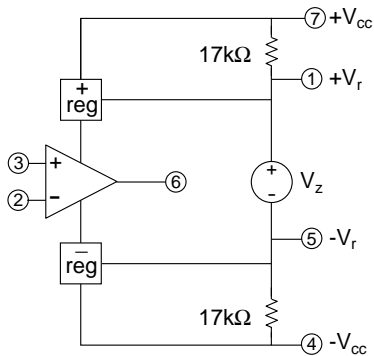
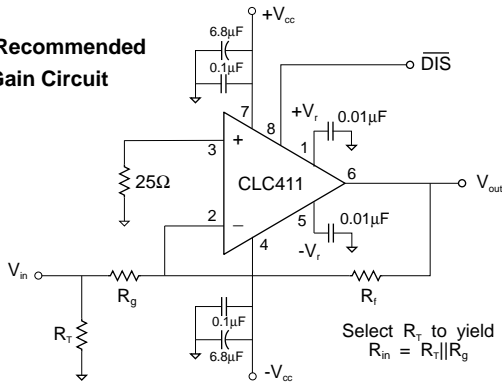

Figure 2: CLC411 Equivalent Circuit

Power Supply Decoupling

There are four pins associated with the power supplies. The V_{CC} pins (4,7) are the external supply voltages. The V_r pins (5,1) are connected to internal reference nodes. Figures 1 and 3, “Recommended Non-inverting Gain Circuit” and “Recommended Inverting Gain Circuit” show the recommended supply decoupling scheme with four ceramic and two electrolytic capacitors. The ceramic capacitors must be placed

Figure 3: Recommended Inverting Gain Circuit



immediately adjacent to the device pins and connected directly to a good low-inductance ground plane. Bypassing the V_r pins will reduce high frequency noise ($>10MHz$) in the amplifier. If this noise is not a concern these capacitors may be eliminated.

Differential Gain and Phase

The differential gain and phase errors of the CLC411 driving one doubly-terminated video load ($R_L=150\Omega$) are specified and guaranteed in the “Electrical Characteristics” table. The “Typical Performance” plot, “Differential Gain and Phase (4.43MHz)” shows the differential gain and phase performance of the CLC411 when driving from one to four video loads. Application note OA-08, “Differential Gain and Phase for Composite Video Systems,” describes in detail the techniques used to measure differential gain and phase.

Feedback Resistor

The loop gain and frequency response for a current-feedback operational amplifier is determined largely by the feedback resistor, R_f . The electrical characteristics and typical performance plots contained within the datasheet, unless otherwise stated, specify an R_f of 301Ω , a gain of $+2V/V$ and operation with $\pm 15V$ power supplies. The frequency response at different gain settings and supply voltages can be optimized by selecting a different value of R_f . Generally, lowering R_f will peak the frequency response and extend the bandwidth while increasing its value will

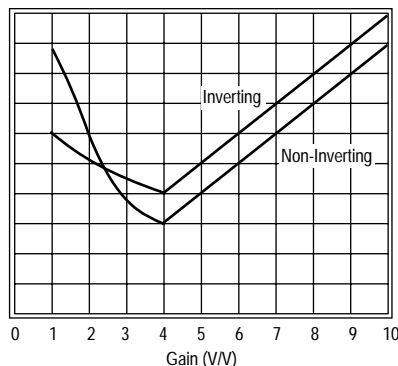

Figure 4: Recommended R_f vs. Gain

roll off the response. For unity-gain voltage follower circuits, a non-zero R_f must be used with current-feedback operational amplifiers such as the CLC411. Application note OA-13, "Current-Feedback Loop-Gain Analysis and Performance Enhancements," explains the ramifications of R_f and how to use it to tailor the desired frequency response with respect to gain. The equations found in the application note should be considered as a starting point for the selection of R_f . The equations do not factor in the effects of parasitic capacitance found on the inverting input, the output nor across the feedback resistor. Equations in OA-13 require values for R_f (301 Ω), A_v (+2) and R_i (inverting input resistance, 50 Ω). Combining these values yields a Z_i^* (optimum feedback transimpedance) of 400 Ω . Figure 4 entitled "Recommended R_f vs. Gain" will enable the selection of the feedback resistor that provides a maximally flat

frequency response for the CLC411 over its gain range. The linear portion of the two curves (i.e. $A_v > 4$) results from the limitation on R_g (i.e. $R_g \geq 50\Omega$).

Enable/Disable Operation

The disable feature allows the outputs of several CLC411 devices to be connected onto a common analog bus forming a high-speed analog multiplexer. When disabled, the output and inverting inputs of the CLC411 become high impedances. The disable pin has an internal pull-up resistor which is pulled-up to an internal voltage, not to the external supply. The CLC411 is enabled when pin 8 is left open or pulled-up to $\geq +7V$ and disabled when grounded or pulled below +3V. CMOS logic devices are necessary to drive the disable pin. For example, CMOS logic with $V_{DD} \geq +7V$ will guarantee proper operation over temperature. TTL voltage levels are inadequate for controlling the disable feature.

For faster enable/disable operation than 15V CMOS logic devices will allow, the circuit of Figure 5 is recommended. A fast four-transistor comparator, Figure 5A, interfaces between the CLC411 DISABLE pin and several standard logic families. This circuit has a differential input between the bases of Q1 and Q2. As such it may be driven directly from differential

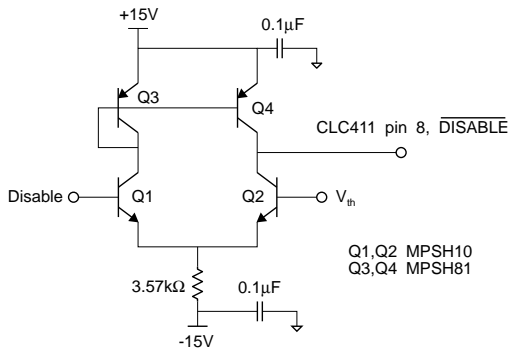

Figure 5A: Disable Interface

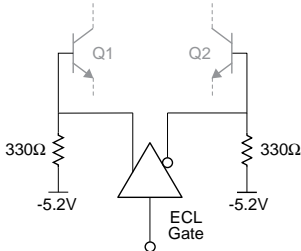

Figure 5B: Differential ECL Interface

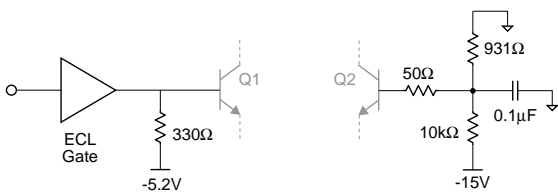

Figure 5C: ECL Interface

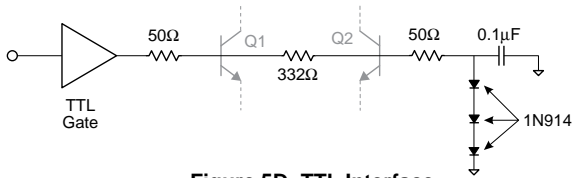

Figure 5D: TTL Interface

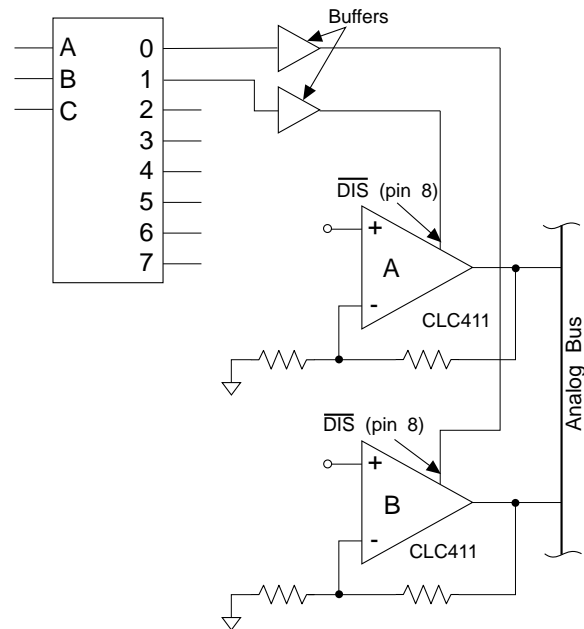

Figure 6: General Multiplexing Circuit

ECL logic, as in shown in Figure 5B. Single-ended logic families may also be used by establishing an appropriate threshold voltage on the V_{th} input, the base of Q2. Figures 5C and 5D illustrate a single-ended ECL and TTL interface respectively. The Disable input, the base of Q1, is driven above and below the threshold, V_{th} .

Fastest switching speeds result when the differential voltage between the bases of Q1 and Q2 is kept to less than one volt. Single-ended ECL, Figure 5C, maintains this desired maximum differential input voltage. TTL and CMOS have higher V_{high} to V_{low} excursions. The circuit of figure 5D will ensure the voltage applied between the bases of Q1 and Q2 does not cause excessive switching delays in the CLC411. Under the above proscribed four-transistor interface, all variations were evaluated with approximately 1ns rise and fall times which produced switching speeds equivalent to the rated disable/enable switching times found in the "CLC411 Electrical Characteristics" table.

A general multiplexer configuration using several CLC411s is illustrated in figure 6, where a typical 8-to-1 digital mux is used to control the switching operation of the paralleled CLC411s. Since "break-before-make" is a guaranteed specification of the CLC411 this configuration works nicely. Notice the buffers used in driving the disable pins of the CLC411s. These buffers may be 15V CMOS logic devices mentioned previously or any variation of the four-transistor comparator illustrated above.

Extending Input/Output Range with V_r

As can be seen in Figure 3, the magnitude of the internal regulated supply voltages is fixed by V_z . In normal operation, with $\pm 15V$ external supplies, $+V_r$ is nominally +9V when left floating. CMIR (common

mode input range) and VO (output voltage range, no load) are specified under these conditions. These parameters implicitly have 0V as their midpoint, i.e. the VO range is $\pm 6V$, centered at 0V.

An external voltage source can be applied to $+V_r$ to shift the range of the input/output voltages. For example, if it were desired to move the positive VO range from +6V to a +9V maximum in unipolar operation, Figure 7, "DC Parameters as a Function of $+V_r$ ", is used to determine the required supply and $+V_r$ voltages. Referring to Figure 7, locate the point on the $+VO_{max}$ line where the ordinate is +9V. Draw a vertical line from this point intersecting the other lines in the graph. The circuit voltages are the ordinates of these intersections. For this example these points are shown in the graph as solid dots. The required voltage sources are $+V_r = +12V$, $+V_{CC} = +12V$, $-V_{CC} = -12V$. When these supply and reference voltages are applied, the range for VO is -3V to +9V, and CMIR ranges from -1V to +7V. The difference between the minimum and maximum voltages is constant, i.e. 12V for VO, only the midpoint has been shifted, i.e. from 0V to +3V for VO.

Note that in this example the $-V_r$ pin has been left open (or bypassed to reduce high-frequency noise). The difference between $+V_r$ and $-V_r$ is fixed by V_z . A level-shifting voltage can be applied to only one of the reference pins, not both. If extended operation were needed in the negative direction, Figure 4 may be used by changing the signs, and applying the resultant negative voltage to the $-V_r$ pin. It is recommended that $+V_r$ be used for positive shifts, and $-V_r$ for negative shifts of input/output voltage range.

Printed Circuit Layout & Evaluation Board

Refer to application note OA-15, "Frequent Faux Pas in Applying Wideband Current Feedback Amplifiers," for board layout guidelines and construction techniques. Two very important points to consider before creating a layout which are found in the above application note are worth reiteration. First the input and output pins are sensitive to parasitic capacitances. These parasitic capacitances can cause frequency-response peaking or sustained oscillation. To minimize the adverse effect of parasitic capacitances, the ground plane should be removed from those pins to a distance of at least 0.25" Second, leads should be kept as short as possible in the finished layout. In particular, the feedback resistor should have its shortest lead on the inverting input side of the CLC411. The output is less sensitive to parasitic capacitance and therefore can drive the longer of the two feedback resistor connections. The evaluation board available for the CLC411 (part #730013 for through-hole packages, 730027 for SO-8) may be used as a reference for proper board layout. Application schematics for this evaluation board are in the product accessories section of the Comlinear databook.

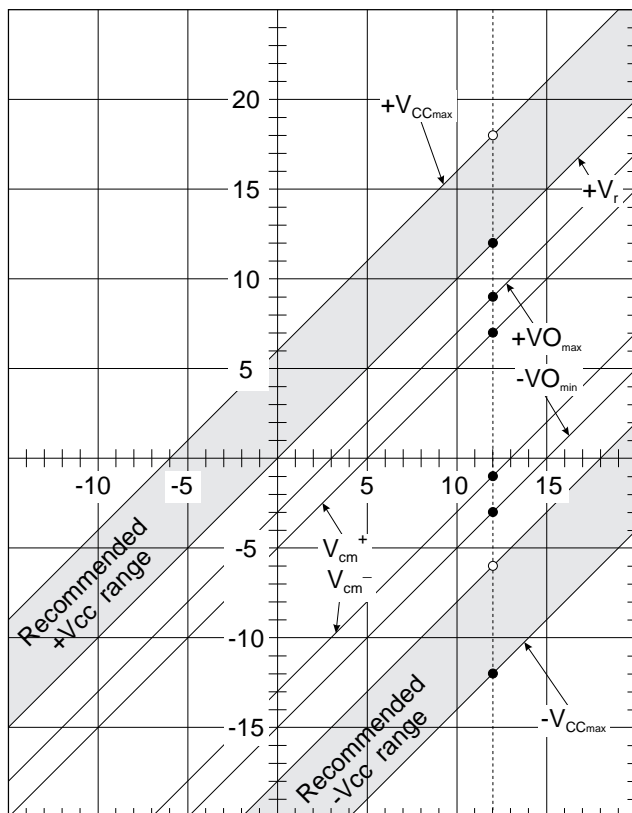

Figure 7: DC Parameters as a Function of $+V_r$

This page intentionally left blank.

Customer Design Applications Support

National Semiconductor is committed to design excellence. For sales, literature and technical support, call the National Semiconductor Customer Response Group at **1-800-272-9959** or fax **1-800-737-7018**.

Life Support Policy

National's products are not authorized for use as critical components in life support devices or systems without the express written approval of the president of National Semiconductor Corporation. As used herein:

1. Life support devices or systems are devices or systems which, a) are intended for surgical implant into the body, or b) support or sustain life, and whose failure to perform, when properly used in accordance with instructions for use provided in the labeling, can be reasonably expected to result in a significant injury to the user.
2. A critical component is any component of a life support device or system whose failure to perform can be reasonably expected to cause the failure of the life support device or system, or to affect its safety or effectiveness.



National Semiconductor Corporation

1111 West Bardin Road
Arlington, TX 76017
Tel: 1(800) 272-9959
Fax: 1(800) 737-7018

National Semiconductor Europe

Fax: (+49) 0-180-530 85 86
E-mail: europe.support.nsc.com
Deutsch Tel: (+49) 0-180-530 85 85
English Tel: (+49) 0-180-532 78 32
Francais Tel: (+49) 0-180-532 93 58
Italiano Tel: (+49) 0-180-534 16 80

National Semiconductor Hong Kong Ltd.

13th Floor, Straight Block
Ocean Centre, 5 Canton Road
Tsimshatsui, Kowloon
Hong Kong
Tel: (852) 2737-1600
Fax: (852) 2736-9960

National Semiconductor Japan Ltd.

Tel: 81-043-299-2309
Fax: 81-043-299-2408

National does not assume any responsibility for use of any circuitry described, no circuit patent licenses are implied and National reserves the right at any time without notice to change said circuitry and specifications.