

# Comlinear CLC414

## Quad, Low-Power Monolithic Op Amp

### General Description

The CLC414 is a low-power, quad, monolithic operational amplifier designed for intermediate-gain applications where power and cost per channel are of primary concern. Benefiting from Comlinear's current feedback architecture, the CLC414 offers a gain range of  $\pm 1$  to  $\pm 10$  while providing stable, oscillation-free operation without external compensation, even at unity gain.

Operating from  $\pm 5V$  supplies, the CLC414 consumes only 25mW of power per channel, yet maintains a 90MHz small-signal bandwidth and a 1000V/ $\mu s$  slew rate. The CLC414 also provides wide channel isolation with its 70dB crosstalk (input referred at 5MHz). Applications requiring a high-density solution to high-speed amplification such as active filters and instrumentation diff amps will benefit from the CLC414's four integrated, wideband op amps in one 14-pin package.

Commercial remote-sensing applications and battery-powered radio transceivers requiring high-performance, low-power amplifiers will find the CLC414 to be an attractive, cost-effective solution. In composite video switching and distribution applications, the CLC414 offers differential gain and phase performance of 0.1%, 0.12° at 3.58MHz.

The lower power CLC414 and the wideband CLC415 are quad versions of the CLC406. Both of these quads afford the designer lower power consumption and lower cost per channel with the additional benefit of requiring less board space per amplifier.

Constructed using an advanced, complementary bipolar process and Comlinear's proven current feedback architectures, the CLC414 is available in several versions to meet a variety of requirements.

|           |                 |   |
|-----------|-----------------|---|
| CLC414AJP | -40°C to +85°C  | 14-pin plastic DIP                                  |
| CLC414AJE | -40°C to +85°C  | 14-pin plastic SOIC                                 |
| CLC414ALC | -40°C to +85°C  | dice  |
| CLC414AMC | -55°C to +125°C | dice qualified to Method 5008, MIL-STD-883, Level B |
| CLC414A8D | -55°C to +125°C | 14-pin side-brazed CERDIP, MIL-STD-883, Level B     |
| CLC414A8B | -55°C to +125°C | 14-pin hermetic CERDIP, MIL-STD-883, Level B        |

DESC SMD number: 5962-91693

### Features

- 90MHz small signal bandwidth
- 2mA quiescent current per amplifier
- 70dB channel isolation @ 5MHz
- 0.1%/0.12° differential gain/phase
- 16ns settling to 0.1%
- 100V/ $\mu s$  slew rate
- 3.3ns rise and fall time ( $2V_{pp}$ )
- 70mA output current

### Applications

- Composite video distribution amps
- HDTV amplifiers
- RGB-video amplifiers
- CCD signal processing
- Active filters
- Instrumentation diff. amps
- General purpose high density requirements

Small Signal Pulse Response

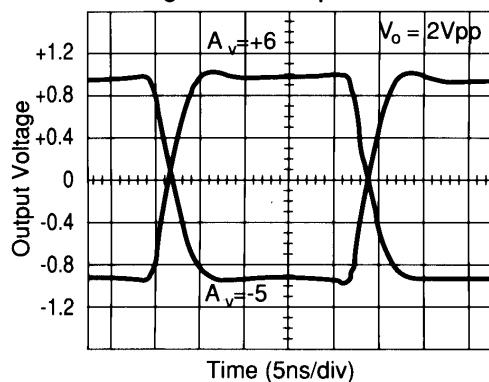

### Package Dimensions

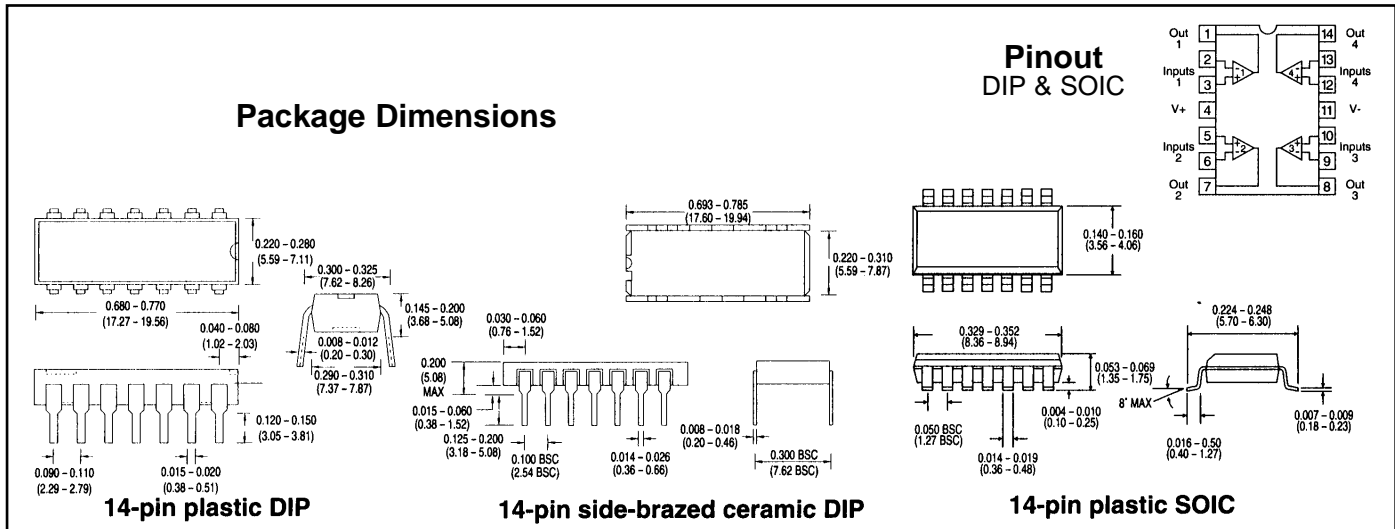

### Pinout DIP & SOIC

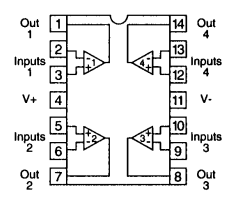

# CLC414 Electrical Characteristics ( $A_v = +6$ , $V_{cc} = \pm 5V$ , $R_L = 100\Omega$ , $R_f = 500\Omega$ ; unless specified)

| PARAMETERS                            | CONDITIONS            | TYP   | MAX & MIN RATINGS |       |        | UNITS              | SYMBOL |
|---------------------------------------|-----------------------|-------|-------------------|-------|--------|--------------------|--------|
|                                       |                       |       |                   |       |        |                    |        |
| Ambient Temperature                   | CLC414AJ/AI           | +25°C | -40°C             | +25°C | +85°C  |                    |        |
| Ambient Temperature                   | CLC414A8/AL/AM        | +25°C | -55°C             | +25°C | +125°C |                    |        |
| <b>FREQUENCY DOMAIN RESPONSE</b>      |                       |       |                   |       |        |                    |        |
| † -3dB bandwidth                      | $V_{out} < 2V_{pp}$   | 90    | >60               | >60   | >45    | MHz                | SSBW   |
|                                       | $V_{out} < 5V_{pp}$   | 55    | >35               | >40   | >35    | MHz                | LSBW   |
| gain flatness <sup>1</sup>            | $V_{out} < 2V_{pp}$   |       |                   |       |        |                    |        |
| † peaking                             | DC to 15MHz           | 0     | <0.15             | <0.15 | <0.15  | dB                 | GFPL   |
| † peaking                             | >15MHz                | 0     | <0.3              | <0.3  | <0.3   | dB                 | GFPH   |
| † rolloff                             | DC to 30MHz           | 0.3   | <1.0              | <1.0  | <1.5   | dB                 | GFR    |
| linear phase deviation                | DC to 30MHz           | 0.8   | <1.2              | <1.2  | <1.5   | °                  | LPD    |
| differential gain ( $A_v = +2$ )      | 150Ω load, 3.58MHz    | 0.10  | <0.15             | <0.20 | <0.25  | %                  | DG1    |
|                                       | 4.43MHz               | 0.12  | <0.20             | <0.25 | <0.30  | %                  | DG2    |
| differential phase ( $A_v = +2$ )     | 150Ω load, 3.58MHz    | 0.12  | <0.15             | <0.20 | <0.50  | °                  | DP1    |
|                                       | 4.43MHz               | 0.15  | <0.20             | <0.25 | <0.60  | °                  | DP2    |
| crosstalk input referred              | 5MHz (all hostile)    | 60    | <58               | <58   | <56    | dB                 | XT     |
| input referred                        | 5MHz (chan. to chan.) | 70    | <63               | <63   | <61    | dB                 | CXT    |
| <b>TIME DOMAIN RESPONSE</b>           |                       |       |                   |       |        |                    |        |
| rise and fall time                    | 2V step               | 3.3   | <5.0              | <5.0  | <6.5   | ns                 | TRS    |
|                                       | 5V step               | 4.0   | <7.0              | <6.0  | <7.0   | ns                 | TRL    |
| settling time to 0.1%                 | 2V step               | 16    | <24               | <24   | <30    | ns                 | TS1    |
| to 0.02%                              | 2V step               | 60    | <80               | <80   | <100   | ns                 | TS2    |
| overshoot                             | 2V step               | 5     | <10               | <10   | <10    | %                  | OS     |
| slew rate                             |                       | 1000  | >600              | >600  | >480   | V/μs               | SR     |
| <b>DISTORTION AND NOISE RESPONSE</b>  |                       |       |                   |       |        |                    |        |
| † 2nd harmonic distortion             | $2V_{pp}$ , 5MHz      | -47   | <-41              | <-41  | <-37   | dBc                | HD2    |
| † 3rd harmonic distortion             | $2V_{pp}$ , 5MHz      | -55   | <-47              | <-47  | <-45   | dBc                | HD3    |
| equivalent noise input                |                       |       |                   |       |        |                    |        |
| non-inverting voltage                 | >1MHz                 | 4.2   | <5.0              | <5.0  | <5.5   | nV/√Hz             | VN     |
| inverting current                     | >1MHz                 | 9.8   | <11.8             | <11.8 | <13.0  | pA/√Hz             | ICN    |
| non-inverting current                 | >1MHz                 | 1.3   | <1.6              | <1.6  | <1.8   | pA/√Hz             | NCN    |
| total noise floor                     | >1MHz                 | -154  | <-153             | <-153 | <-152  | dBm <sub>1Hz</sub> | SNF    |
| total integrated noise                | >1MHz to 75MHz        | 37    | <44               | <44   | <48    | μV                 | INV    |
| <b>STATIC, DC PERFORMANCE</b>         |                       |       |                   |       |        |                    |        |
| *input offset voltage                 |                       | 2     | <10.5             | <6    | <14    | mV                 | VIO    |
| average temperature coefficient       |                       | 30    | <80               | —     | <80    | μV/°C              | DVIO   |
| *input bias current non-inverting     |                       | 1     | <10               | <5    | <5     | μA                 | IBN    |
| average temperature coefficient       |                       | 20    | <75               | —     | <30    | nA/°C              | DIBN   |
| *input bias current inverting         |                       | 2     | <20               | <6    | <10    | μA                 | IBI    |
| average temperature coefficient       |                       | 20    | <140              | —     | <75    | nA/°C              | DIBI   |
| †power supply rejection ratio         |                       | 50    | >46               | >46   | >44    | dB                 | PSRR   |
| common mode rejection ratio           |                       | 50    | >45               | >45   | >43    | dB                 | CMRR   |
| *supply current, all channels no load |                       | 10    | <11.5             | <11.5 | <11.5  | mA                 | ICC    |
| <b>MISCELLANEOUS PERFORMANCE</b>      |                       |       |                   |       |        |                    |        |
| non-inverting input resistance        |                       | 2000  | >500              | >1000 | >1000  | kΩ                 | RIN    |
| non-inverting input capacitance       |                       | 1.0   | <2.0              | <2.0  | <2.0   | pF                 | CIN    |
| output impedance                      | DC                    | 0.2   | <0.6              | <0.3  | <0.2   | Ω                  | RO     |
| output voltage range                  | $R_L = 100\Omega$     | ±2.8  | ±2.5              | ±2.6  | ±2.7   | V                  | VO     |
| common mode input range               |                       | ±2.2  | ±1.4              | ±2.0  | ±2.0   | V                  | CMIR   |
| output current                        |                       | 70    | 30                | 50    | 50     | mA                 | IO     |

Min/max ratings are based on product characterization and simulation. Individual parameters are tested as noted. Outgoing quality levels are determined from tested parameters.

## Absolute Maximum Ratings

|                                     |  |
|-------------------------------------|--|
| $V_{cc}$                            | ±7V  |
| $I_{out}$                           | output is short circuit protected to ground, however, maximum reliability is obtained if $I_{out}$ does not exceed... 70mA |
| common mode input voltage           | ± $V_{cc}$   |
| differential input voltage          | ±10V   |
| maximum junction temperature        | +175°C   |
| operating temperature range         |  |
| AI/AJ:                              | -40°C to +85°C   |
| A8/AL/AM:                           | -55°C to +125°C  |
| storage temperature range           | -65°C to +150°C  |
| lead temperature (soldering 10 sec) | +300°C   |

## Miscellaneous Ratings

|                         |   |
|-------------------------|---|
| recommended gain range: | ±1 to ±10   |
| <b>Notes:</b>           |   |
| * AI, AJ                | 100% tested at +25°C, sample at +85°C.                      |
| † AJ                    | Sample tested at +25°C.                                     |
| † AI                    | 100% tested at +25°C.                                       |
| * A8                    | 100% tested +25°C, -55°C, +125°C.                           |
| † A8                    | 100% tested +25°C, sample at -55°C, +125°C.                 |
| * AL, AM                | 100% wafer probed at +25°C to +25°C min/max specifications. |
| note 1:                 | Gain flatness tests performed from 0.1MHz                   |

# CLC414 Typical Performance Characteristics ( $T_A = 25^\circ$ , $A_V = +6$ , $V_{CC} = \pm 5V$ , $R_L = 100\Omega$ , $R_f = 500\Omega$ )

**Non-Inverting Frequency Response**

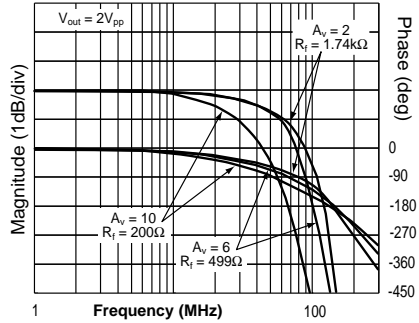

**Inverting Frequency Response**

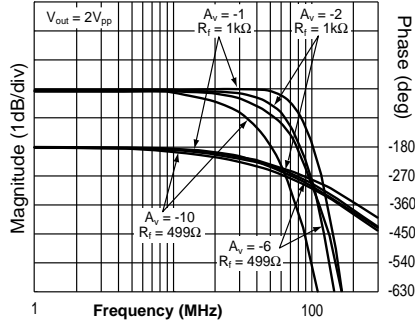

**Frequency Response for Various  $R_L$ s**

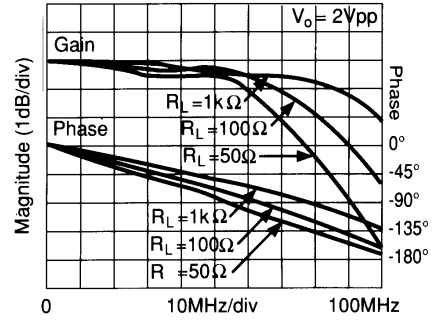

**Small Signal Pulse Response**

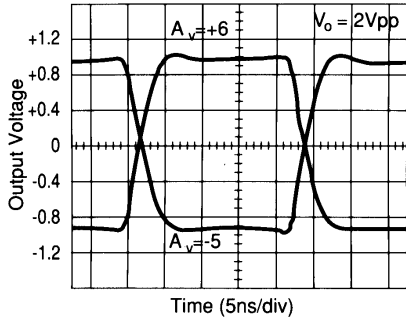

**Short-Term Settling Time**

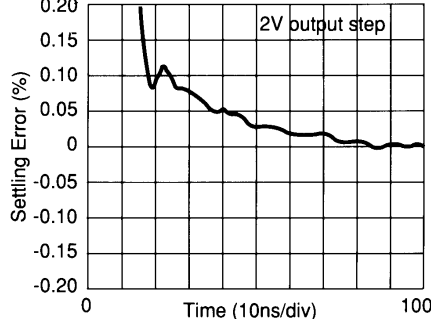

**Long-Term Settling Time**

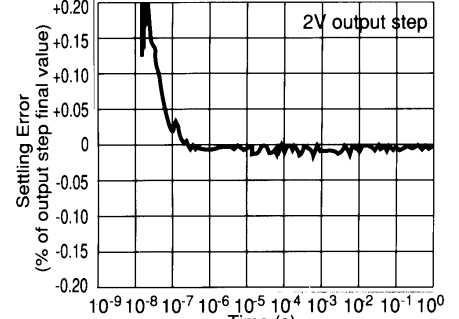

**2nd and 3rd Harmonic Distortion**

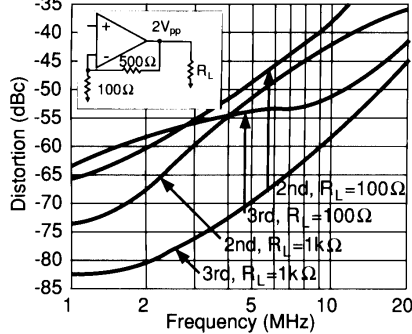

**2-Tone, 3rd Order Spurious Levels**

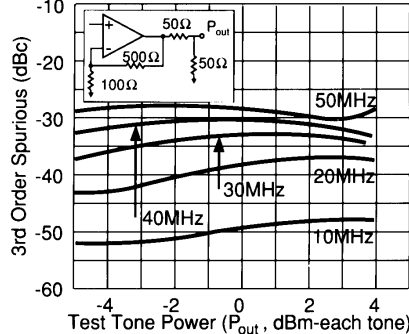

**Settling Time vs. Capacitive Load**

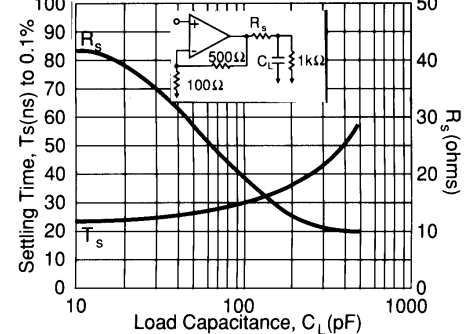

**All-Hostile Crosstalk Isolation**

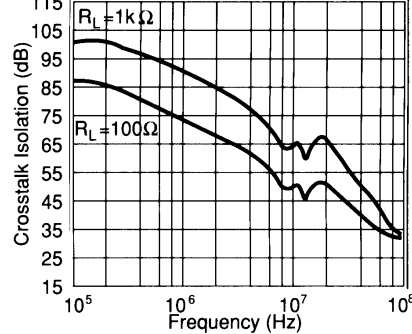

**Most Susceptible Channel-Channel Pulse Coupling**

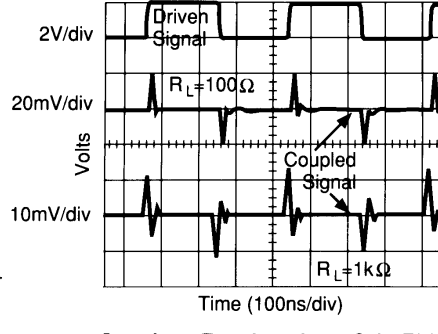

**Differential Gain and Phase (4.43 MHz,  $A_V = +2$ )**

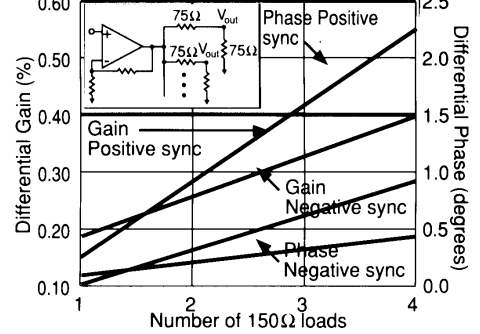

**Equivalent Input Noise**

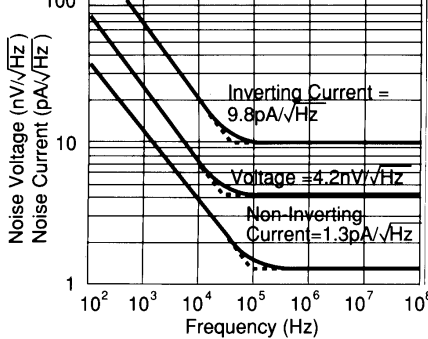

**Open-Loop Transimpedance Gain, Z(s)**

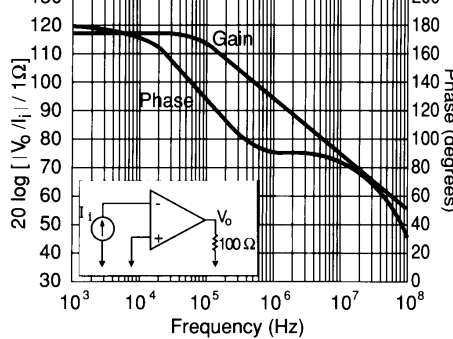

**PSRR, CMRR, and Closed Loop  $R_o$**

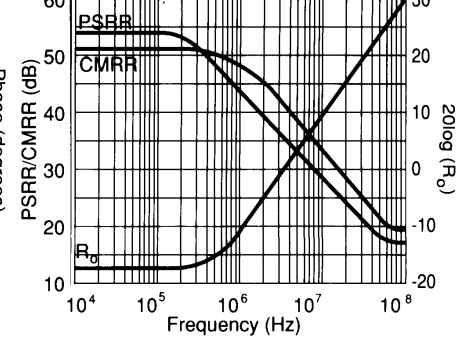

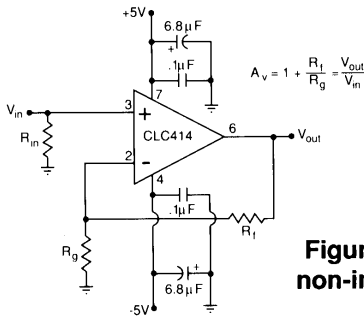

**Figure 1: recommended non-inverting gain circuit**

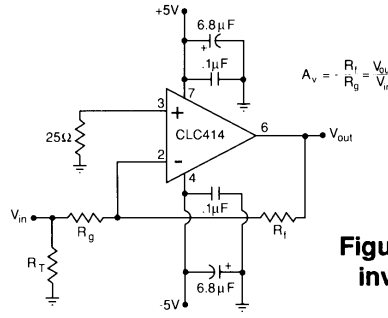

**Figure 2: recommended inverting gain circuit**

### Feedback Resistor

The CLC414 achieves its exceptional AC performance while requiring very low quiescent power by using the current feedback topology and an internal slew rate enhancement circuit. The loop gain and frequency response for a current feedback op amp is predominantly set by the feedback resistor value. The CLC414 is optimized for a gain of +6 to use a 500Ω feedback resistor (use a 1kΩ  $R_f$  for maximally flat response at a gain of +2). Using lower values can lead to excessive ringing in the pulse response while a higher value will limit the bandwidth. Application Note OA-13 provides a more detailed discussion of choosing a feedback resistor. The equations found in this application note are to be considered a starting point for the determination of  $R_f$  at any gain. The value of input impedance for the CLC414 is approximately 250Ω. These equations do not account for parasitic capacitance at the inverting input nor across  $R_f$ . The plot found below entitled “Recommended  $R_f$  vs. Gain” offers values of  $R_f$  which will optimize the frequency response of the CLC414 over its  $\pm 1$  to  $\pm 10$  gain range. Unlike voltage feedback, current feedback op amps require a non-zero  $R_f$  for unity gain followers.

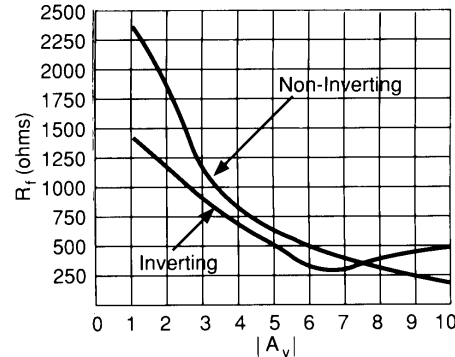

**Figure 3: recommended  $R_f$  vs. gain**

### Unused Amplifiers

It is recommended that any unused amplifiers in the quad package be connected as unity gain followers ( $R_f = 500\Omega$ ) with the non-inverting input tied to ground through a 50Ω resistor.

### Slew Rate and Harmonic Distortion

Please see the application information for the CLC406.

### Differential Gain and Phase

Differential gain and phase performance specifications are common to composite video distribution applications. These specifications refer to the change in small signal gain and phase of the color subcarrier frequency (4.43MHz for PAL composite video) as the amplifier output is swept over a range of DC voltages. Application Note OA-08 provides an additional discussion of differential gain and phase measurements.

### Non-inverting Source Impedance

For best operation, the DC source impedance looking out of the non-inverting input should be less than 3kΩ but greater than 20Ω. Parasitic self oscillations may occur in

the input transistors if the DC source impedance is out of this range. This impedance also acts as the gain for the non-inverting input bias and noise currents and therefore can become troublesome for high values of DC source impedance. The inverting configuration of Figure 2 shows a 25Ω resistor to ground on the non-inverting input which insures stability but does not provide bias current cancellation. The input bias currents are unrelated for a current feedback amplifier which eliminates the need for source impedance matching to achieve bias current cancellation.

### DC Accuracy and Noise Calculation

Please refer to the application information for the CLC406.

### Crosstalk

In any multi-channel integrated circuit there is an undesirable tendency for the signal in one channel to couple with and reproduce itself in the output of another channel. This effect is referred to as crosstalk. Crosstalk is expressed as channel separation or channel isolation which indicates the magnitude of this undesirable effect. This effect is measured by driving one or more channels and observing the output of the other undriven channel(s). The CLC414 plot page offers two different graphs detailing the effect of crosstalk over frequency. One plot entitled “All-Hostile Crosstalk Isolation” graphs all-hostile input-referred crosstalk. All-hostile crosstalk refers to the condition where three channels are driven simultaneously while observing the output of the undriven fourth channel. Input-referred implies that crosstalk is directly affected by gain and therefore a higher gain increases the crosstalk effect by a factor equal to that gain setting. The plot entitled “Most Susceptible Channel-to-Channel Pulse Coupling” describes the effect of crosstalk when one channel is driven with a 2V<sub>pp</sub> pulse while the output of the most effected channel is observed.

### Printed Circuit Layout

As with any high speed component, a careful attention to the board layout is necessary for optimum performance. Of particular importance is the careful control of parasitic capacitances on the output pin. As the output impedance plot shows, the closed loop output for the CLC414 eventually becomes inductive as the loop gain rolls off with increasing frequency. Direct capacitive loading on the output pin can quickly lead to peaking in the frequency response, overshoot in the pulse response, ringing or even sustained oscillations. The “Settling Time vs. Capacitive Load” plot should be used as a starting point for the selection of a series output resistor when a capacitive load must be driven. A quad amplifier will require careful attention to signal routing in order to minimize the effects of crosstalk. Signal coupling through the power supplies can be reduced with bypass capacitors placed close to the device supply pins.

### Evaluation Board

Evaluation PC boards (part number 730024 for through-hole and 730031 for SOIC) for the CLC414 are available.

**This page intentionally left blank.**

---

### Customer Design Applications Support

National Semiconductor is committed to design excellence. For sales, literature and technical support, call the National Semiconductor Customer Response Group at **1-800-272-9959** or fax **1-800-737-7018**.

### Life Support Policy

National's products are not authorized for use as critical components in life support devices or systems without the express written approval of the president of National Semiconductor Corporation. As used herein:

1. Life support devices or systems are devices or systems which, a) are intended for surgical implant into the body, or b) support or sustain life, and whose failure to perform, when properly used in accordance with instructions for use provided in the labeling, can be reasonably expected to result in a significant injury to the user.
2. A critical component is any component of a life support device or system whose failure to perform can be reasonably expected to cause the failure of the life support device or system, or to affect its safety or effectiveness.



#### National Semiconductor Corporation

1111 West Bardin Road  
Arlington, TX 76017  
Tel: 1(800) 272-9959  
Fax: 1(800) 737-7018

#### National Semiconductor Europe

Fax: (+49) 0-180-530 85 86  
E-mail: europe.support.nsc.com  
Deutsch Tel: (+49) 0-180-530 85 85  
English Tel: (+49) 0-180-532 78 32  
Francais Tel: (+49) 0-180-532 93 58  
Italiano Tel: (+49) 0-180-534 16 80

#### National Semiconductor Hong Kong Ltd.

13th Floor, Straight Block  
Ocean Centre, 5 Canton Road  
Tsimshatsui, Kowloon  
Hong Kong  
Tel: (852) 2737-1600  
Fax: (852) 2736-9960

#### National Semiconductor Japan Ltd.

Tel: 81-043-299-2309  
Fax: 81-043-299-2408

---

National does not assume any responsibility for use of any circuitry described, no circuit patent licenses are implied and National reserves the right at any time without notice to change said circuitry and specifications.