

# CLC414

## Quad, Low Power Monolithic Op Amp

### General Description

The CLC414 is a low power, quad, monolithic operational amplifier designed for intermediate gain applications where power and cost per channel are of primary concern. Benefiting from National's current feedback architecture, the CLC414 offers a gain range of  $\pm 1$  to  $\pm 10$  while providing stable, oscillation free operation without external compensation, even at unity gain.

Operating from  $\pm 5V$  supplies, the CLC414 consumes only 25mW of power per channel, yet maintains a 90MHz small signal bandwidth and a 1000V/ $\mu$ s slew rate. The CLC414 also provides wide channel isolation with its 70dB crosstalk (input referred at 5MHz). Applications requiring a high density solution to high speed amplification such as active filters and instrumentation diff amps will benefit from the CLC414's four integrated, wideband op amps in one 14-pin package.

Commercial remote sensing applications and battery powered radio transceivers requiring high performance, low power will find the CLC414 to be an attractive, cost effective solution. In composite video switching and distribution applications, the CLC414 offers differential gain and phase performance of 0.1%, 0.12° at 3.58MHz.

The lower power CLC414 and the wideband CLC415 are quad versions of the CLC406. Both of these quads afford the designer lower power consumption and lower cost per channel with the additional benefit of requiring less board space per amplifier.

Construction using an advanced, complementary bipolar process and National's proven current feedback architecture, the CLC414 is available in several versions to meet a variety of requirements.

### Enhanced Solutions (Military/Aerospace)

SMD Number: 5962-91693

Space level versions also available.

For more information, visit <http://www.national.com/mil>

### Features

- 90MHz small signal bandwidth
- 2mA quiescent current per amplifier
- 70dB channel isolation @ 5MHz
- 0.1%/0.12° differential gain/phase
- 16ns settling to 0.1%
- 100V/ $\mu$ s slew rate
- 3.3ns rise and fall time (2V<sub>PP</sub>)
- 70mA output current

### Applications

- Composite video distribution amps
- HDTV amplifiers
- RGB video amplifiers
- CCD signal processing
- Active filters
- Instrumentation diff. amps
- General purpose high density requirements

#### Small Signal Pulse Response

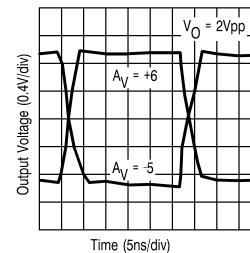

01275016

#### All-Hostile Crosstalk Isolation

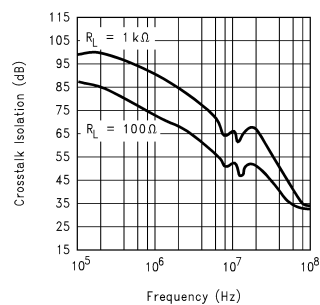

01275007

#### Connection Diagram

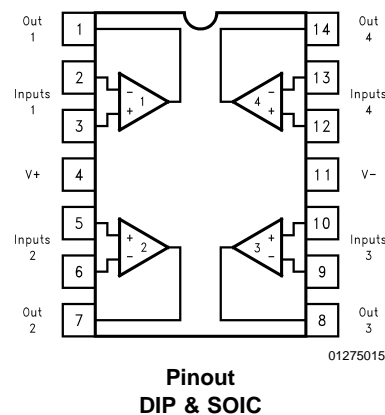

01275015

**Absolute Maximum Ratings** (Note 1)

If Military/Aerospace specified devices are required, please contact the National Semiconductor Sales Office/Distributors for availability and specifications.

Supply Voltage ( $V_{CC}$ )	$\pm 7V$
$I_{OUT}$	
Output is Short Circuit protected to ground, but maximum reliability will be maintained if $I_{OUT}$ does not exceed...	70mA
Common Mode Input Voltage	$\pm V_{CC}$
Differential Input Voltage	$\pm 10V$
Junction Temperature	+150°C

Operating Temperature Range	-40°C to +85°C
Storage Temperature Range	-65°C to +150°C
Lead Temperature Range (Soldering 10 sec)	+300°C
ESD Rating (Human Body Model)	<1000V

**Operating Ratings**

Thermal Resistance			
Package	( $\theta_{JC}$ )	( $\theta_{JA}$ )	
MDIP	60°C/W	110°C/W	
SOIC	45°C/W	115°C/W	

**Electrical Characteristics**

( $A_V = +6$ ,  $V_{CC} = \pm 5V$ ,  $R_L = 100\Omega$ ,  $R_f = 500\Omega$ ; Unless Specified)

Symbol	Parameter	Conditions	Typ	Max/Min (Note 2)			Units
Ambient Temperature		CLC414AJ	+25°C	-40°C	+25°C	+85°C	
<b>Frequency Domain Response</b>							
SSBW	-3dB Bandwidth	$V_{OUT} < 2V_{PP}$	90	>60	>60	>45	MHz
LSBW		$V_{OUT} < 5V_{PP}$	55	>35	>40	>35	MHz
	Gain Flatness	$V_{OUT} < 2V_{PP}$					
GFPL	Peaking	DC to 15MHz	0	<0.15	<0.15	<0.15	dB
GFPH	Peaking	>15MHz	0	<0.3	<0.3	<0.3	dB
GFR	Rolloff	DC to 30MHz	0.3	<1.0	<1.0	<1.5	dB
LPD	Linear Phase Deviation	DC to 30MHz	0.8	<1.2	<1.2	<1.5	deg
DG1	Differential Gain, $A_V = +2$	$R_L = 150\Omega$ , 3.58MHz	0.10	<0.15	<0.20	<0.25	%
DG2		$R_L = 150\Omega$ , 4.43MHz	0.12	<0.20	<0.25	<0.30	%
DP1	Differential Phase, $A_V = +2$	$R_L = 150\Omega$ , 3.58MHz	0.12	<0.15	<0.20	<0.50	deg
DP2		$R_L = 150\Omega$ , 4.43MHz	0.15	<0.20	<0.25	<0.60	deg
XT	Crosstalk Input Referred	5MHz (All Hostile)	60	<58	<58	<56	dB
CXT		5MHz (Chan. to Chan.)	70	<63	<63	<61	dB
<b>Time Domain Response</b>							
TRS	Rise and Fall Time	2V Step	3.3	<5.0	<5.0	<6.5	ns
TRL		5V Step	4.0	<7.0	<6.0	<7.0	ns
TS1	Settling Time	to $\pm 0.1\%$	16	<24	<24	<30	ns
TS2		to 0.02%	60	<80	<80	<100	ns
OS	Overshoot	2V Step	5	<10	<10	<10	%
SR	Slew Rate		1000	>600	>600	>480	V/ $\mu$ s
<b>Distortion And Noise Response</b>							
HD2	2nd Harmonic Distortion	$2V_{PP}$ , 5MHz	-47	<-41	<-41	<-37	dBc
HD3	3rd Harmonic Distortion	$2V_{PP}$ , 5MHz	-55	<-47	<-47	<-45	dBc
Equivalent Noise Input							
VN	Non-Inverting Voltage	>1MHz	4.2	<5.0	<5.0	<5.5	nV/ $\sqrt{Hz}$
ICN	Inverting Current	>1MHz	9.8	<11.8	<11.8	<13.0	pA/ $\sqrt{Hz}$
NCN	Non-Inverting Current	>1MHz	1.3	<1.6	<1.6	<1.8	pA/ $\sqrt{Hz}$
SNF	Total Noise Floor	>1MHz	-154	<-153	<-153	<-152	dBm <sub>1Hz</sub>
INV	Total Integrated Noise	>1MHz to 75MHz	37	<44	<44	<48	$\mu$ V

**Electrical Characteristics** (Continued) $(A_V = +6, V_{CC} = \pm 5V, R_L = 100\Omega, R_f = 500\Omega; \text{ Unless Specified})$ 

Symbol	Parameter	Conditions	Typ	Max/Min (Note 2)			Units
<b>Static, DC Performance</b>							
VIO	Input Offset Voltage (Note 3)		2	<10.5	<6	<14	mV
DVIO	Average Temperature Coefficient		30	<80	-	<80	$\mu\text{V}/\text{C}^\circ$
IBN	Input Bias Current (Note 3)	Non-Inverting	1	<10	<5	<5	$\mu\text{A}$
DIBN	Average Temperature Coefficient		20	<75	-	<30	$\text{nA}/\text{C}^\circ$
IBI	Input Bias Current (Note 3)	Inverting	2	<20	<6	<10	$\mu\text{A}$
DIBI	Average Temperature Coefficient		20	<140	-	<75	$\text{nA}/\text{C}^\circ$
PSRR	Power Supply Rejection Ratio		50	>46	>46	>44	dB
CMRR	Common Mode Rejection Ratio		50	>45	>45	>43	dB
ICC	Supply Current (Note 3)	No Load	10	<11.5	<11.5	<11.5	mA
<b>Miscellaneous Performance</b>							
RIN	Non Inverting Input Resistance		2000	>500	>1000	>1000	k $\Omega$
CIN	Non-Inverting Input Capacitance		1.0	<2.0	<2.0	<2.0	pF
RO	Output Impedance	DC	0.2	<0.6	<0.3	<0.2	$\Omega$
VO	Output Voltage Range	$R_L = 100\Omega$	$\pm 2.8$	$\pm 2.5$	$\pm 2.6$	$\pm 2.7$	V
CMIR	Common Mode Input Range		$\pm 2.2$	$\pm 1.4$	$\pm 2.0$	$\pm 2.0$	V
IO	Output Current		70	30	50	50	mA

**Note 1:** "Absolute Maximum Ratings" are those values beyond which the safety of the device cannot be guaranteed. They are not meant to imply that the devices should be operated at these limits. The table of "Electrical Characteristics" specifies conditions of device operation.

**Note 2:** Max/min ratings are based on product characterization and simulation. Individual parameters are tested as noted. Outgoing quality levels are determined from tested parameters.

**Note 3:** AJ-level: spec. is 100% tested at +25°C.

**Ordering Information**

Package	Temperature Range Industrial	Part Number	Package Marking	NSC Drawing
14-pin plastic DIP	-40°C to +85°C	CLC414AJP	CLC414AJP	N14A
14-pin plastic SOIC	-40°C to +85°C	CLC414AJE	CLC414AJE	M14A

**Typical Performance Characteristics** ( $T_A = 25^\circ$ ,  $A_V = +6$ ,  $V_{CC} = \pm 5V$ ,  $R_L = 100\Omega$ ,  $R_f = 500\Omega$ ; Unless Specified).

**Non-Inverting Frequency Response**

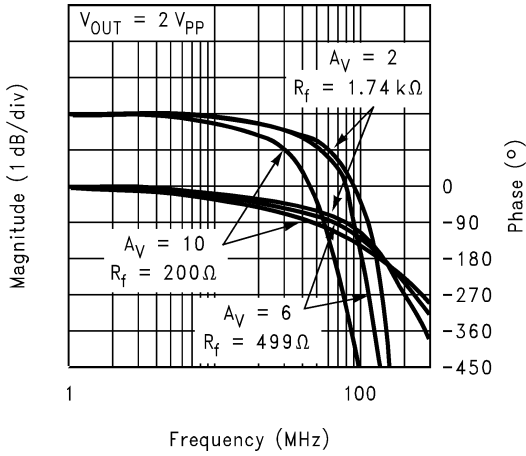

01275001

**Inverting Frequency Response**

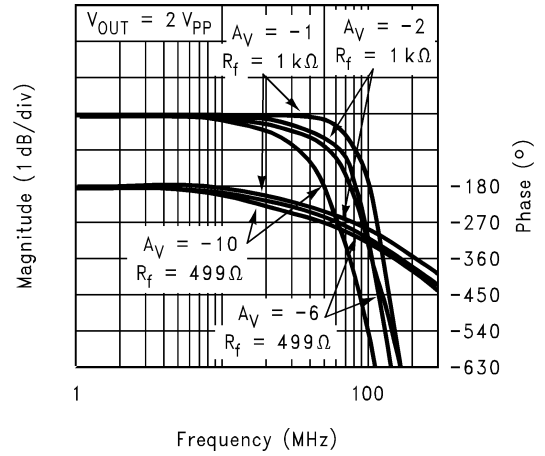

01275002

**Frequency Response for Various  $R_L$ S**

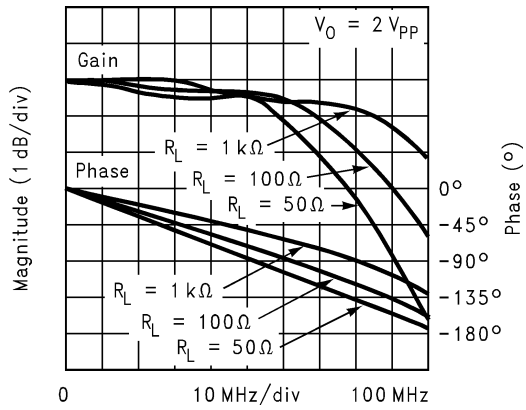

01275003

**Small Signal Pulse Response**

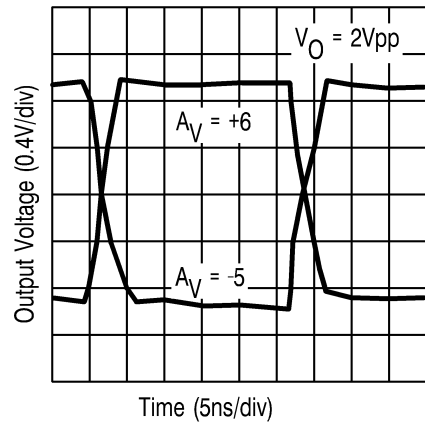

01275016

**Short-Term Settling Time**

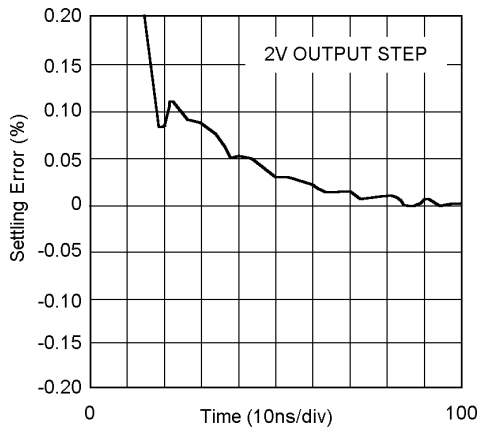

01275017

**Long-Term Settling Time**

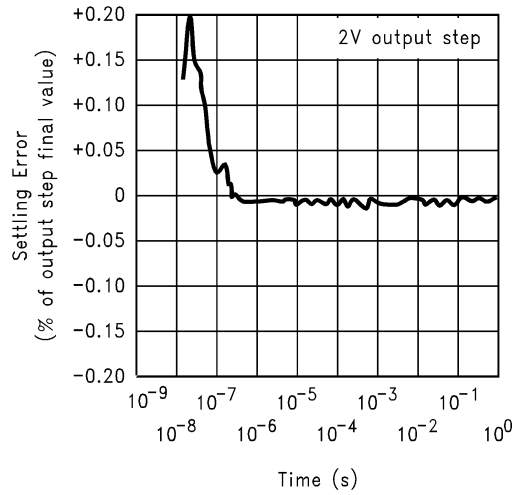

01275018

**Typical Performance Characteristics** ( $T_A = 25^\circ$ ,  $A_V = +6$ ,  $V_{CC} = \pm 5V$ ,  $R_L = 100\Omega$ ,  $R_f = 500\Omega$ ; Unless Specified). (Continued)

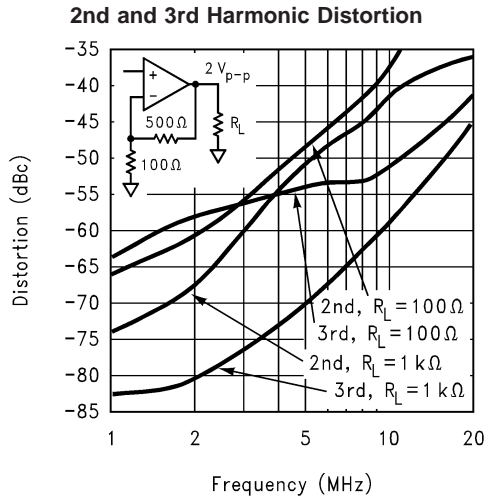

01275004

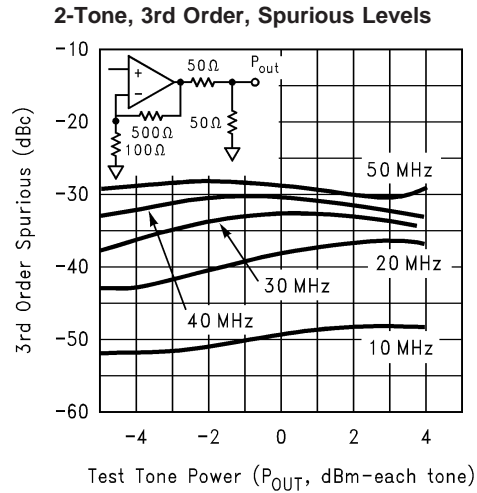

01275005

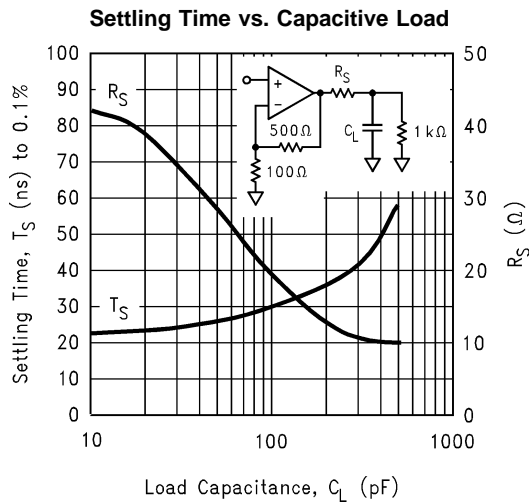

01275006

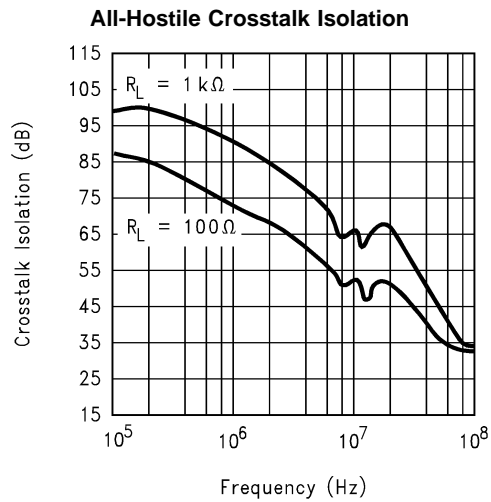

01275007

**Most Susceptible Channel-Channel Pulse Coupling**

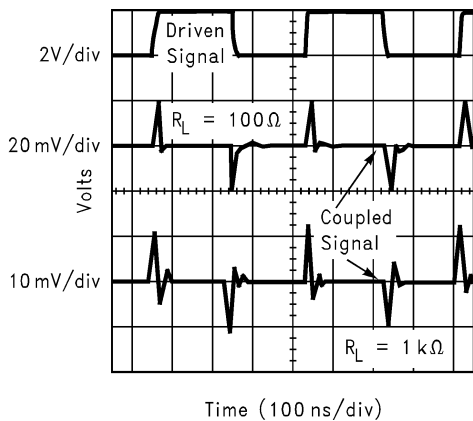

01275008

**Differential Gain and Phase (4.43 MHz,  $A_V = +2$ )**

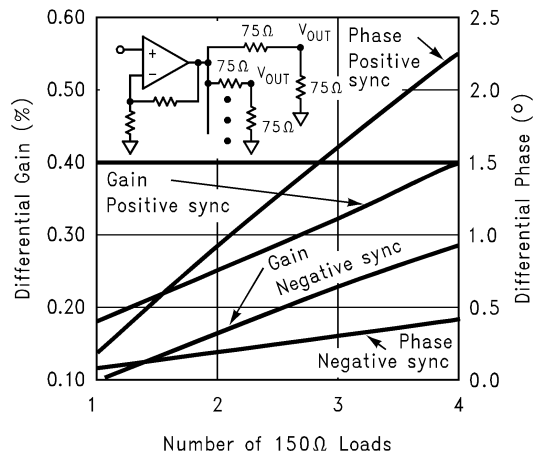

01275009

**Typical Performance Characteristics** ( $T_A = 25^\circ$ ,  $A_V = +6$ ,  $V_{CC} = \pm 5V$ ,  $R_L = 100\Omega$ ,  $R_f = 500\Omega$ ; Unless Specified). (Continued)

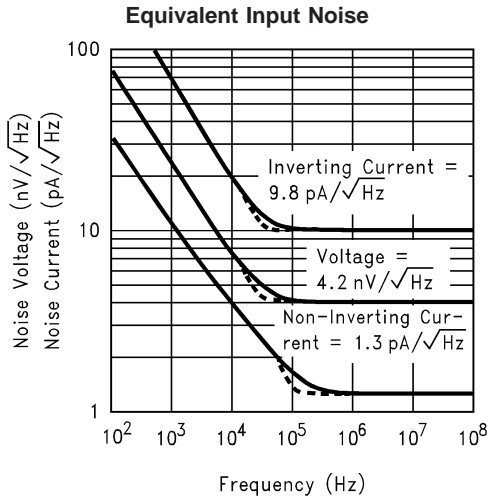

01275010

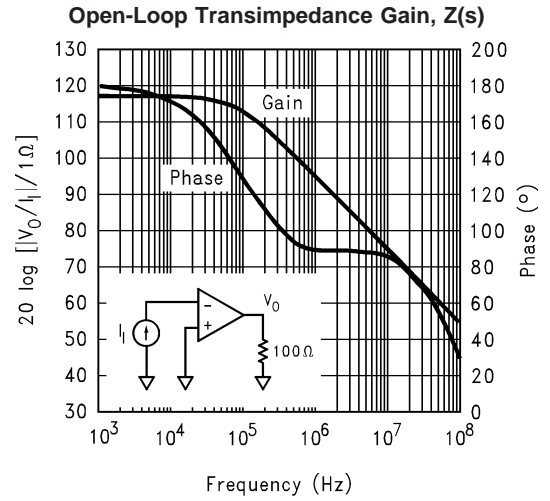

01275011

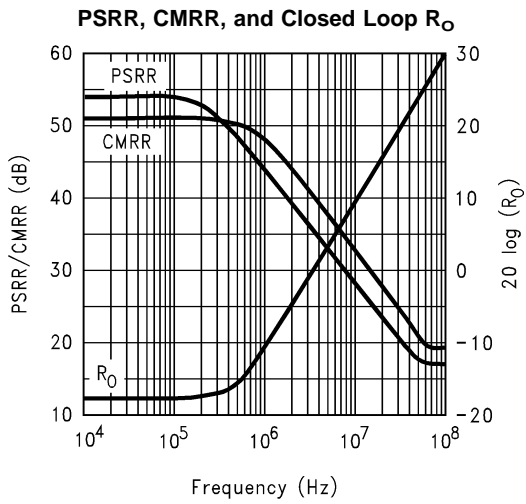

01275012

## Application Division

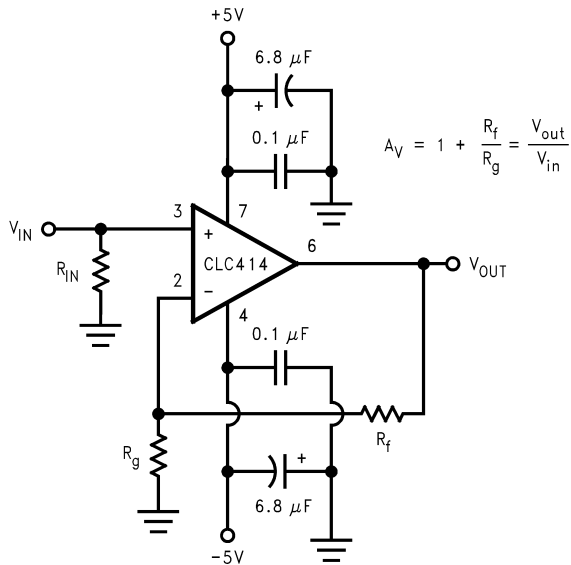

01275013

FIGURE 1. Recommended Non-Inverting Gain Circuit

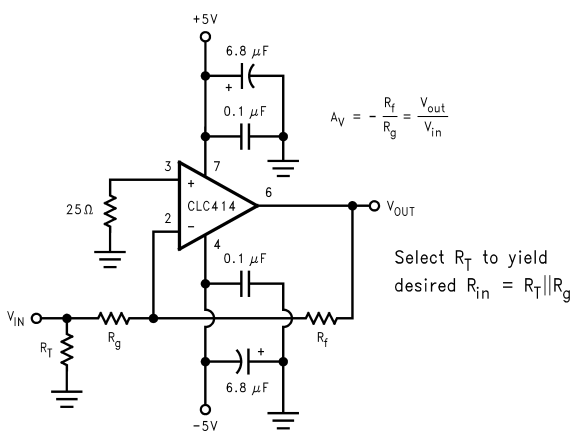

01275014

FIGURE 2. Recommended Inverting Gain Circuit

### Feedback Resistor

The CLC414 achieves its exceptional AC performance while requiring very low quiescent power by using the current feedback topology and an internal slew rate enhancement circuit. The loop gain and frequency response for a current feedback op amp is predominantly set by the feedback resistor value. The CLC414 is optimized for a gain of +6 to use a 500Ω feedback resistor (**use a 1kΩ R<sub>f</sub> for maximally flat response at a gain of +2**). Using lower values can lead to excessive ringing in the pulse response while a higher value will limit the bandwidth. Application Note OA-13 provides a more detailed discussion of choosing a feedback resistor. The equations found in this application note are to be considered a starting point for the determination of R<sub>f</sub> at any gain. The value of input impedance of the CLC414 is approximately 250Ω. These equations do not account for parasitic capacitance at the inverting input nor across R<sub>f</sub>. The plot found below entitled "Recommended R<sub>f</sub> vs. Gain" offers values of R<sub>f</sub> which will optimize the frequency re-

sponse of the CLC414 over its ±1 to ±10 gain range. Unlike voltage feedback, current feedback op amps require a non-zero R<sub>f</sub> for unity gain followers.

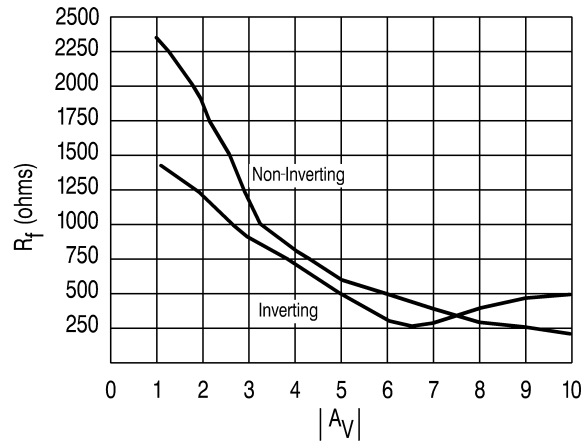

01275019

FIGURE 3. Recommended R<sub>f</sub> vs. Gain

### Unused Amplifiers

It is recommended that any unused amplifiers in the quad package be connected as unity gain followers (R<sub>f</sub> = 500Ω) with the non-inverting input tied to ground through a 50Ω resistor.

### Slew Rate and Harmonic Distortion

Please see the application information for the CLC406.

### Differential Gain and Phase

Differential gain and phase performance specifications are common to composite video distribution applications. These specifications refer to the change in small signal gain and phase of the color subcarrier frequency (4.43MHz for PAL composite video) as the amplifier output is swept over a range of DC voltages. Application Note OA-08 provides an additional discussion of differential gain and phase measurements.

### Non-inverting Source Impedance

For best operation, the DC source impedance looking out of the non-inverting input should be less than 3kΩ but greater than 20Ω. Parasitic self oscillations may occur in the input transistors if the DC source impedance is out of this range. This impedance also acts as the gain for the non-inverting input bias and noise currents and therefore can become troublesome for high values of DC source impedance. The inverting configuration of Figure 2 shows a 25Ω resistor to ground on the non-inverting input which insures stability but does not provide bias current cancellation. The input bias currents are unrelated for a current feedback amplifier which eliminates the need for source impedance matching to achieve bias current cancellation.

### DC Accuracy and Noise Calculation

Please refer to the application information for the CLC406.

### Crosstalk

In any multi-channel integrated circuit there is an undesirable tendency for the signal in one channel to couple with and reproduce itself in the output of another channel. This effect is referred to as crosstalk. Crosstalk is expressed as channel separation or channel isolation which indicates the

## Application Division (Continued)

magnitude of this undesirable effect. This effect is measured by driving one or more channels and observing the output of the other undriven channel(s). The CLC414 plot page offers two different graphs detailing the effect of crosstalk over frequency. One plot entitled "All-Hostile Crosstalk Isolation" graphs all-hostile input-referred crosstalk. All-hostile crosstalk refers to the condition where three channels are driven simultaneously while observing the output of the undriven fourth channel. Input-referred implies that crosstalk is directly affected by gain and therefore a higher gain increases the crosstalk effect by a factor equal to that gain setting. The plot entitled "Most Susceptible Channel-to-Channel Pulse Coupling" describes the effect of crosstalk when one channel is driven with a  $2V_{PP}$  pulse while the output of the most effected channel is observed.

### Printed Circuit Layout

As with any high speed component, a careful attention to the board layout is necessary for optimum performance. Of par-

ticular importance is the careful control of parasitic capacitances on the output pin. As the output impedance plot shows, the closed loop output for the CLC414 eventually becomes inductive as the loop gain rolls off with increasing frequency. Direct capacitive loading on the output pin can quickly lead to peaking in the frequency response, overshoot in the pulse response, ringing or even sustained oscillations. The "Settling Time vs. Capacitive Load" plot should be used as a starting point for the selection of a series output resistor when a capacitive load must be driven. A quad amplifier will require careful attention to signal routing in order to minimize the effects of crosstalk. Signal coupling through the power supplies can be reduced with bypass capacitors placed close to the device supply pins.

### Evaluation Board

Evaluation PC boards (part number 730024 for through-hole and 730031 for SOIC) for the CLC414 are available.

**Physical Dimensions** inches (millimeters)

unless otherwise noted

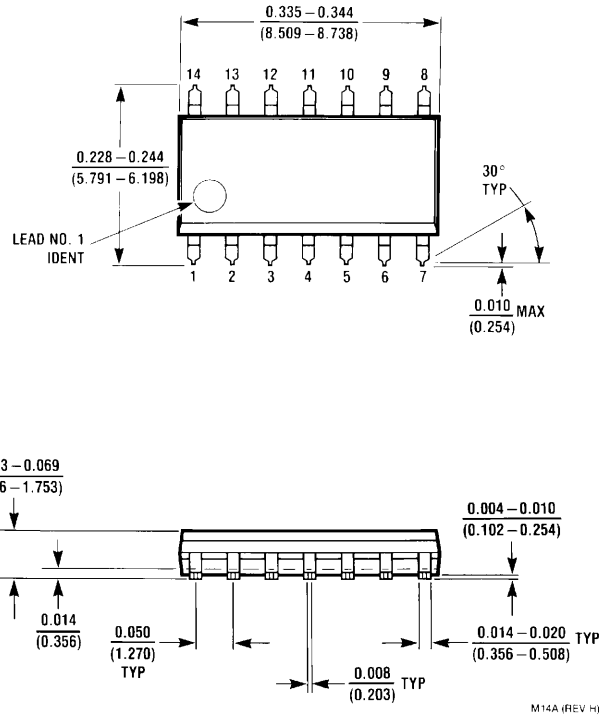

M14A (REV H)

**14-Pin SOIC  
NS Package Number M14A**

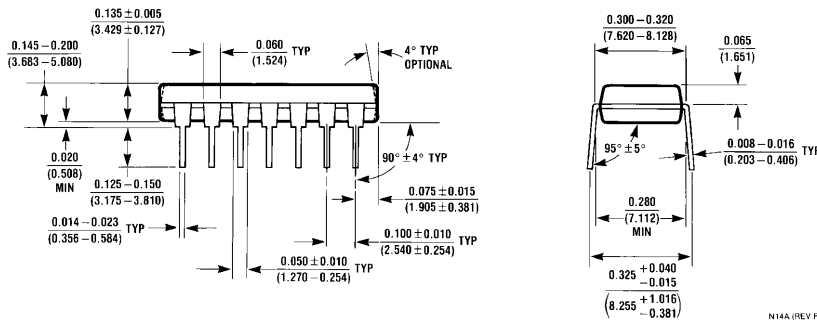
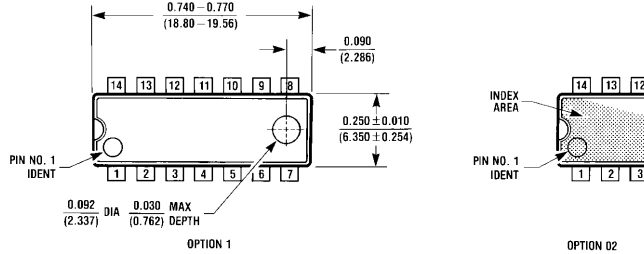

N14A (REV F)

**14-Pin MDIP  
NS Product Number N14A**

## Notes

**LIFE SUPPORT POLICY**

NATIONAL'S PRODUCTS ARE NOT AUTHORIZED FOR USE AS CRITICAL COMPONENTS IN LIFE SUPPORT DEVICES OR SYSTEMS WITHOUT THE EXPRESS WRITTEN APPROVAL OF THE PRESIDENT AND GENERAL COUNSEL OF NATIONAL SEMICONDUCTOR CORPORATION. As used herein:

1. Life support devices or systems are devices or systems which, (a) are intended for surgical implant into the body, or (b) support or sustain life, and whose failure to perform when properly used in accordance with instructions for use provided in the labeling, can be reasonably expected to result in a significant injury to the user.
2. A critical component is any component of a life support device or system whose failure to perform can be reasonably expected to cause the failure of the life support device or system, or to affect its safety or effectiveness.



**National Semiconductor Corporation**  
Americas  
Email: support@nsc.com

www.national.com

**National Semiconductor Europe**

Fax: +49 (0) 180-530 85 86  
Email: europe.support@nsc.com  
Deutsch Tel: +49 (0) 69 9508 6208  
English Tel: +44 (0) 870 24 0 2171  
Français Tel: +33 (0) 1 41 91 8790

**National Semiconductor Asia Pacific Customer Response Group**

Tel: 65-2544466  
Fax: 65-2504466  
Email: ap.support@nsc.com

**National Semiconductor Japan Ltd.**

Tel: 81-3-5639-7560  
Fax: 81-3-5639-7507