

# Comlinear CLC420 High-Speed, Voltage Feedback Op Amp

## General Description

The CLC420 is an operational amplifier designed for applications requiring matched inputs, integration or transimpedance amplification. Utilizing voltage feedback architecture, the CLC420 offers a 300MHz bandwidth, a 1100V/ $\mu$ s slew rate and a 4mA supply current (power consumption of 40mW,  $\pm$ 5V supplies). Additional benefits of the CLC420B are a 0.5mV input offset voltage and a 4 $\mu$ V/ $^{\circ}$ C temperature coefficient.

Applications such as differential amplifiers will benefit from 70dB common mode rejection ratio and an input offset current of 0.2 $\mu$ A. With its unity-gain stability, 2pA/ $\sqrt$ Hz current noise and 3 $\mu$ A of input bias current, the CLC420 is designed to meet the needs of filter applications and log amplifiers. The low input offset current and current noise, combined with a settling time of 18ns to 0.01% make the CLC420 ideal for D/A converters, pin diode receivers and photo multipliers amplifiers. All applications will find 70dB power supply rejection ratio attractive.

The CLC420 is available in several versions to meet a variety of requirements:

CLC420AJP/BJP	-40 $^{\circ}$ C to +85 $^{\circ}$ C	8-pin plastic DIP
CLC420AJE/BJE	-40 $^{\circ}$ C to +85 $^{\circ}$ C	8-pin plastic SOIC
CLC420ALC	-40 $^{\circ}$ C to +85 $^{\circ}$ C	dice
CLC420AMC	-55 $^{\circ}$ C to +125 $^{\circ}$ C	dice qualified to Method 5008, MIL-STD-883, Level B
CLC420AIB/BIB	-40 $^{\circ}$ C to +85 $^{\circ}$ C	8-pin CERDIP
CLC420A8D/B8D	-55 $^{\circ}$ C to +125 $^{\circ}$ C	8-pin sidebrazed CERDIP, MIL-STD-883, Level B
CLC420A8B/B8B	-55 $^{\circ}$ C to +125 $^{\circ}$ C	8-pin CERDIP, MIL-STD-883

DESC SMD number: 5962-90994

## Features

- 300MHz small signal bandwidth
- 1100V/ $\mu$ s slew rate
- Unity-gain stability
- Low distortion, -60dBc at 20MHz
- 0.01% settling in 18ns
- CLC420B: 0.5mV input offset voltage, 4 $\mu$ V/ $^{\circ}$ C
- 0.2 $\mu$ A input offset current
- 2pA/ $\sqrt$ Hz current noise

## Applications

- Active filters/integrators
- Differential amplifiers
- Pin diode receivers
- Log amplifiers
- D/A converters
- Photo multiplier amplifiers

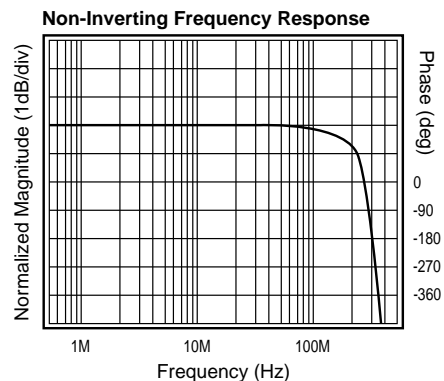

## Package Dimensions

### Pinout DIP & SOIC

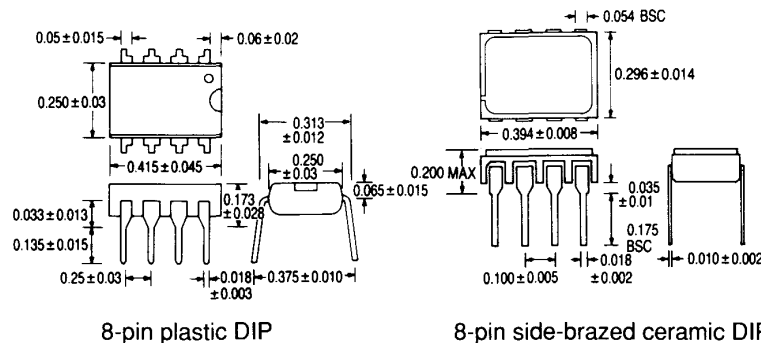
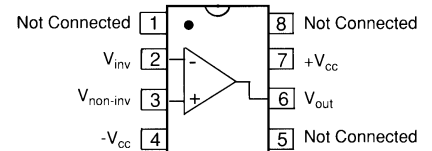

# CLC420 Electrical Characteristics ( $A_v = +1$ , $V_{cc} = \pm 5V$ , $R_L = 100\Omega$ , $R_f = 0\Omega$ ; unless specified)

PARAMETER	CONDITIONS	TYP	MAX & MIN RATINGS			UNITS	SYMBOL
Ambient Temperature	CLC420A8/B8/AL/AM	+25°C	-55°C	+25°C	+125°C		
Ambient Temperature	CLC420AJ/BJ/BI	+25°C	-40°C	+25°C	+85°C		
<b>FREQUENCY DOMAIN RESPONSE</b>							
-3dB bandwidth	$V_{OUT} < 0.4V_{pp}$	300	>200	>200	>130	MHz	SSBW
	$V_{OUT} < 5V_{pp}$	40	>20	>25	>20	MHz	LSBW
† $A_v = -1$ , $R_f = 500\Omega$	$V_{OUT} < 0.4V_{pp}$	100	>65	>65	>45	MHz	SSBWI
$A_v = -1$ , $R_f = 500\Omega$	$V_{OUT} < 5V_{pp}$	60	>30	>35	>30	MHz	LSBWI
gain flatness	$V_{OUT} < 0.4V_{pp}$						
peaking	0.1MHz to 100MHz	0	<1	<0.6	<0.6	dB	GFPL
peaking	>100MHz	0	<5	<3	<3	dB	GFPH
rolloff	0.1MHz to 100MHz	0.2	<1	<1	<2	dB	GFR
†rolloff, $A_v = -1$ , $R_f = 500\Omega$	0.1MHz to 30MHz	0.2	<1.4	<1.4	<1.6	dB	GFR1
linear phase deviation	0.1MHz to 100MHz	0.9	<1.8	<1.8	<2.5	°	LPD
<b>TIME DOMAIN RESPONSE</b>							
rise and fall time	0.4V step	1.2	<2	<2	<3	ns	TRS
	5V step	14	<25	<20	<20	ns	TRL
rise and fall time, $A_v = -1$ , $R_f = 500\Omega$	0.4V step	3.5	<5.5	<5.5	<7.8	ns	TRSI
	5V step	6	<10	<9.5	<10	ns	TRLI
settling time to $\pm 0.1\%$	2V step	12	<18	<18	<18	ns	TSS
$\pm 0.01\%$	2V step	18	<25	<25	<25	ns	TSP
overshoot	0.4V step	8	<35	<25	<25	%	OS
slew rate	5V step	1100	>600	>750	>600	V/ $\mu$ s	SR
slew rate, $A_v = -1$ , $R_f = 500\Omega$	5V step	750	>430	>500	>430	V/ $\mu$ s	SRI
<b>DISTORTION AND NOISE RESPONSE</b>							
2 <sup>ND</sup> harmonic distortion	2V <sub>pp</sub> , 20MHz	-50	<-40	<-40	<-40	dBc	HD2
3 <sup>RD</sup> harmonic distortion	2V <sub>pp</sub> , 20MHz	-53	<-45	<-45	<-40	dBc	HD3
†2 <sup>ND</sup> harmonic distortion, $A_v = -1$ , 2V <sub>pp</sub> , 20MHz, $R_f = 500\Omega$		-51	<-40	<-40	<-40	dBc	HD2
†3 <sup>RD</sup> harmonic distortion, $A_v = -1$ , 2V <sub>pp</sub> , 20MHz, $R_f = 500\Omega$		-51	<-40	<-40	<-35	dBc	HD3
input referred noise							
voltage	1MHz to 200MHz	4.2	<5.3	<5.3	<6	nV/ $\sqrt{Hz}$	VN
current	1MHz to 200MHz	2	<2.9	<2.6	<2.3	pA/ $\sqrt{Hz}$	ICN
<b>STATIC DC PERFORMANCE</b>							
*input offset voltage (A version)		1	<3.2	<2	<3.5	mV	VIO
average temperature coefficient		8	<15	—	<15	$\mu$ V/°C	DVIO
*input offset voltage (B version)		0.5	<1.6	<0.8	<1.8	mV	VIOB
average temperature coefficient		4	<10	—	<10	$\mu$ V/°C	DVIOB
*input bias current		3	<20	<10	<10	$\mu$ A	IB
average temperature coefficient		45	<120	—	<60	nA/°C	DIB
*input offset current		0.2	<2.6	<1	<2	$\mu$ A	IIO
average temperature coefficient		2	<20	—	<10	nA/°C	DIIO
*open loop gain		65	>52	>56	>56	dB	AOL
†power supply rejection ratio		70	>55	>60	>60	dB	PSRR
common mode rejection ratio		80	>60	>65	>65	dB	CMRR
*supply current	no load, quiescent	4	<5	<5	<5	mA	ICC
<b>MISCELLANEOUS PERFORMANCE</b>							
differential mode input	resistance	2	>0.5	>1	>1	M $\Omega$	RIND
	capacitance	1	<2	<2	<2	pF	CIND
common mode input	resistance	1	>0.25	>0.5	>0.5	M $\Omega$	RINC
	capacitance	1	<2	<2	<2	pF	CINC
output impedance	at DC	0.02	<0.3	<0.2	<0.2	$\Omega$	RO
output voltage range	no load	$\pm 3.6$	$\pm 2.8$	$\pm 3$	$\pm 3$	V	VO
*output voltage range	$R_L = 100\Omega$	$\pm 2.9$	$\pm 2.5$	$\pm 2.5$	$\pm 2.5$	V	VOL
common mode input range		$\pm 3.2$	$\pm 2.5$	$\pm 2.8$	$\pm 2.8$	V	CMIR
output current	(AJ/BJ/BI/BI/AL/AM)	$\pm 70$	$\pm 30$	$\pm 50$	$\pm 50$	mA	IO
output current	(A8/B8)	$\pm 70$	$\pm 30$	$\pm 35$	$\pm 35$	mA	IO

Min/max ratings are based on product characterization and simulation. Individual parameters are tested as noted. Outgoing quality levels are determined from tested parameters.

## Absolute Maximum Ratings

## Miscellaneous Ratings

$V_{cc}$	$\pm 7V$
$I_{out}$	
(is short circuit protected to ground, maximum reliability maintained if $I_{out}$ does not exceed 70mA, except A8D, B8D which should not exceed 35mA over the military temperature range)	
common mode input voltage	$\pm V_{cc}$
differential input voltage	10V
junction temperature	+175°
operating temperature range	
AI/AJ/BI/BJ:	-40°C to +85°C
A8/B8/AL/AM:	-55°C to +125°C
storage temperature range	-65°C to +150°C
lead solder duration (+300°C)	10 sec

recommended gain range:  $\pm 1$  to  $\pm 10$

### Notes:

- \* AI, AJ, BI, BJ 100% tested at +25°C, sample at +85°C.
- † AJ, BJ Sample tested at +25°C.
- ‡ AI, BI 100% tested at +25°C.
- \* A8, B8 100% tested at +25°C, -55°C, +125°C.
- † A8, B8 100% tested at +25°C, sample at -55°C, +125°C.
- \* AL, AM 100% wafer probed at +25°C to +25°C min/max specifications.

# CLC420 Typical Performance Characteristics ( $A_v = +1$ , $V_{CC} = \pm 5V$ , $R_L = 100\Omega$ , $R_f = 0\Omega$ ; unless specified)

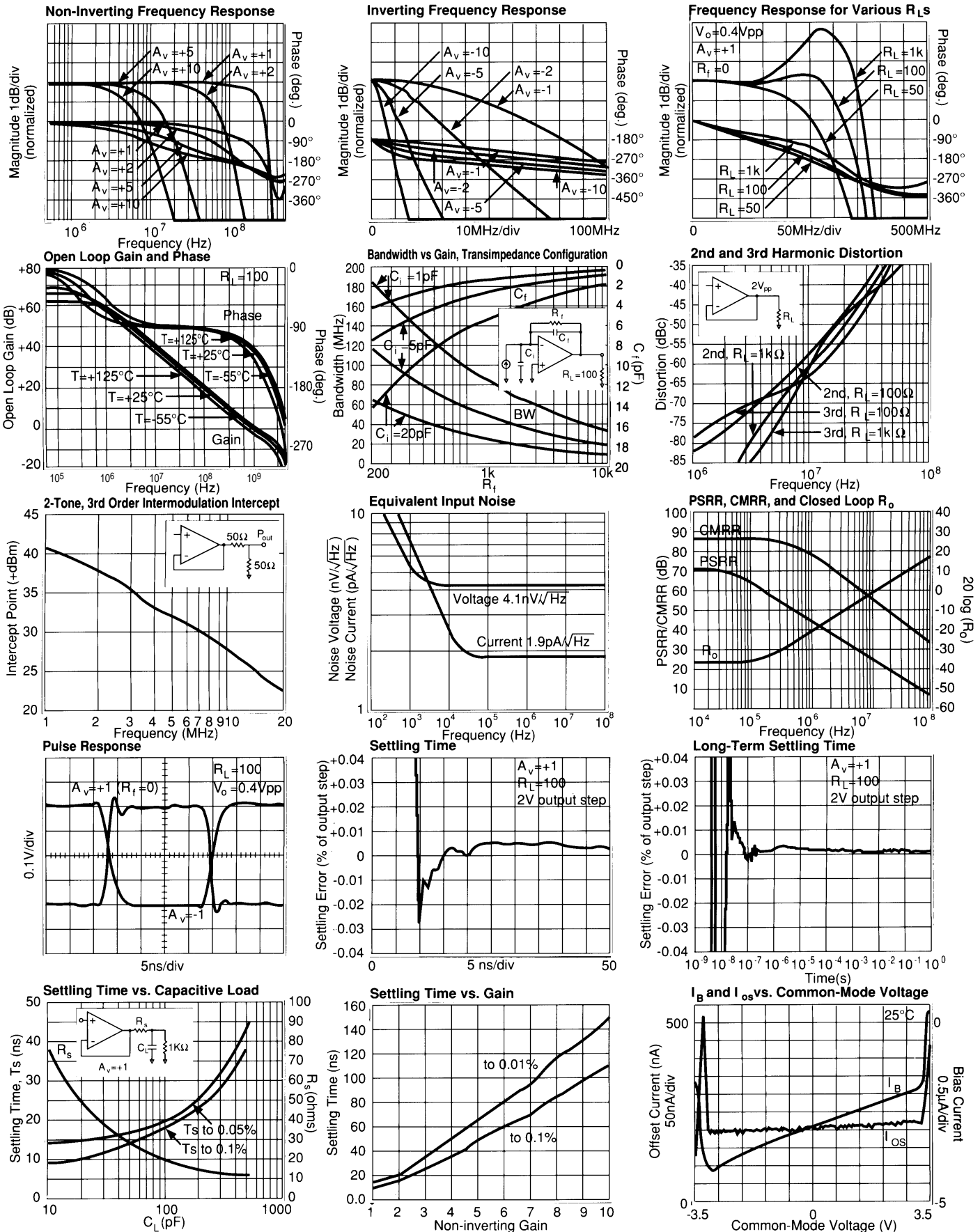

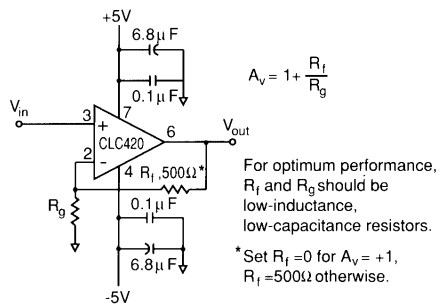

**Figure 1: recommended non-inverting gain circuit**

**Description**

The CLC420 is a high-speed, slew-booster, voltage-feedback amplifier with unity-gain stability. These features along with matched inputs, low input bias and noise currents, and excellent CMRR render the CLC420 very attractive for active filters, differential amplifiers, log amplifiers, and transimpedance amplifiers.

**DC accuracy**

Unlike current-feedback amplifiers, voltage-feedback amplifiers have matched inputs. This means that the non-inverting and inverting input bias currents are well matched and track over temperature, etc. As a result, by matching the resistance looking out of the two inputs, these errors can be reduced to a small offset current term.

**Gain bandwidth product**

Since the CLC420 is a voltage-feedback op-amp, closed-loop bandwidth is approximately equal to the gain-bandwidth product (typically 100MHz) divided by the noise gain of the circuit (for noise gains greater than 5). At lower noise gains, higher-order amplifier poles contribute to higher closed-loop bandwidth. At low gains use the frequency response performance plots given in the data sheet.

Another point to remember is that the closed-loop bandwidth is determined by the noise gain, not the signal gain of the circuit. Noise gain is the reciprocal of the attenuation in the feedback network enclosing the op amp. For example, a CLC420 setup as a non-inverting amplifier with a closed-loop gain of +1 (a noise gain of 1) has a 300MHz bandwidth. When used as an inverting amplifier with a gain of -1 (a noise gain of 2), the bandwidth is less, typically only 100MHz.

**Full-power bandwidth, and slew-rate**

The CLC420 combines exceptional full-power bandwidths (40MHz,  $V_{O} = 5V_{pp}$ ,  $A_V = +1$ ) and slew rates (1100V/ $\mu s$ ,  $A_V = +1$ ) with low (40mW) power consumption. These attractive results are achieved by using slew-boosting circuitry to keep the slew rates high while consuming very little power.

In non-slew boosted amplifiers, full-power bandwidth can be easily determined from slew-rate measurements, but in slew-boosted amplifiers, such as the CLC420, you can't. For this reason we provide data for both.

Slew rate is also different for inverting and non-inverting configurations. This occurs because common-mode signal voltages are present in non-inverting circuits but absent in inverting circuits. Once again data is provided for both.

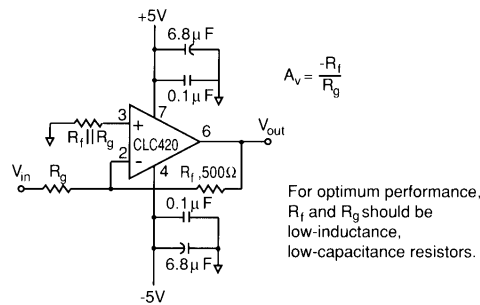

**Figure 2: recommended inverting gain circuit**

**Transimpedance amplifier circuits**

Low inverting, input current noise (2pA/ $\sqrt{Hz}$ ) makes the CLC420 ideal for high-sensitivity transimpedance amplifier circuits for applications such as pin-diode optical receivers, and detectors in receiver IFs. However, feedback resistors 4k $\Omega$  or greater are required if feedback resistor noise current is going to be less than the input current noise contribution of the op-amp.

With feedback resistors this large, shunt capacitance on the inverting input of the op-amp (from the pin-diode, etc.) will unacceptably degrade phase margin causing frequency response peaking or oscillations. A small-valued capacitor shunting the feedback resistor solves this problem (Note: This approach does not work for a current-feedback op-amp configured for transimpedance applications). To determine the value of this capacitor, refer to the "Transimpedance BW vs.  $R_f$  and  $C_i$ " plot.

For example, let's assume an optical transimpedance receiver is being developed. Total capacitance from the inverting input to ground, including the photodiode and strays is 5pF. A 5k $\Omega$  feedback resistor value has been determined to provide best dynamic range based on the responsivity of the photodiode and the range of incident optical powers, etc. From the "Transimpedance BW vs.  $R_f$  and  $C_i$ " plot, using  $C_i = 5pF$  it is determined from the two curves labeled  $C_i = 5pF$ , that  $C_f = 1.5pF$  provides optimal compensation (no more than 0.5dB frequency response peaking) and a -3dB bandwidth of approximately 27MHz.

**Printed circuit layout**

As with any high frequency device, a good PCB layout will enhance performance. Ground plane construction and good power supply bypassing close to the package are critical to achieving full performance. The amplifier is sensitive to stray capacitance to ground at the output and inverting input: Node connections should be small with minimal coupling to the ground plane.

Parasitic or load capacitance directly on the output (pin 6) will introduce additional phase shift in the loop degrading the loop phase margin and leading to frequency response peaking. A small series resistor before this capacitance, if present, effectively decouples this effect. The graphs on the preceding page, "Settling Time vs.  $C_L$ ", illustrate the required resistor value and resulting performance vs. capacitance.

Evaluation PC boards (part number 730013 for through-hole and 730027 for SOIC) for the CLC420 are available.

**This page intentionally left blank.**

---

### Customer Design Applications Support

National Semiconductor is committed to design excellence. For sales, literature and technical support, call the National Semiconductor Customer Response Group at **1-800-272-9959** or fax **1-800-737-7018**.

### Life Support Policy

National's products are not authorized for use as critical components in life support devices or systems without the express written approval of the president of National Semiconductor Corporation. As used herein:

1. Life support devices or systems are devices or systems which, a) are intended for surgical implant into the body, or b) support or sustain life, and whose failure to perform, when properly used in accordance with instructions for use provided in the labeling, can be reasonably expected to result in a significant injury to the user.
2. A critical component is any component of a life support device or system whose failure to perform can be reasonably expected to cause the failure of the life support device or system, or to affect its safety or effectiveness.



#### National Semiconductor Corporation

1111 West Bardin Road  
Arlington, TX 76017  
Tel: 1(800) 272-9959  
Fax: 1(800) 737-7018

#### National Semiconductor Europe

Fax: (+49) 0-180-530 85 86  
E-mail: europe.support.nsc.com  
Deutsch Tel: (+49) 0-180-530 85 85  
English Tel: (+49) 0-180-532 78 32  
Francais Tel: (+49) 0-180-532 93 58  
Italiano Tel: (+49) 0-180-534 16 80

#### National Semiconductor Hong Kong Ltd.

13th Floor, Straight Block  
Ocean Centre, 5 Canton Road  
Tsimshatsui, Kowloon  
Hong Kong  
Tel: (852) 2737-1600  
Fax: (852) 2736-9960

#### National Semiconductor Japan Ltd.

Tel: 81-043-299-2309  
Fax: 81-043-299-2408

---

National does not assume any responsibility for use of any circuitry described, no circuit patent licenses are implied and National reserves the right at any time without notice to change said circuitry and specifications.