

Comlinear CLC427 Dual Voltage Feedback Amplifier for Single Supply Operation

General Description

The Comlinear CLC427 is a dual wideband voltage-feedback operational amplifier that is uniquely designed to provide high performance from a single power supply. This CLC427 provides near rail-to-rail operation and the common-mode input range includes the negative rail. Each of the CLC427's amplifiers offers plenty of headroom for single-supply applications as evidenced by its 4.3V_{pp} output voltage from a single 5V supply.

Fabricated with a high-speed complementary bipolar process, the CLC427 delivers a wide 94MHz unity-gain bandwidth, 7.5ns rise/fall time and 150V/μs slew rate. For single supply applications such as video distribution or desktop multimedia, the CLC427 offers low 0.35%, 0.55° differential gain and phase errors.

Each of the CLC427's amplifiers provides high signal fidelity with -74/-94dBc 2nd/3rd harmonics (1V_{pp}, 1MHz, R_L=150Ω). Combining this high fidelity performance with CLC427's quick 46ns settling time to 0.1% makes it an excellent choice for ADC buffering.

With its traditional voltage-feedback architecture and high-speed performance, the CLC427 is the perfect choice for composite signal conditioning circuit functions such as active filters, integrators, differentiators, simple gain blocks and buffering.

Features

- Single +5V supply
- Input includes V_{EE}
- 94MHz unity-gain bandwidth
- -74/-94dBc HD2/HD3
- 60mA output current
- 7.5ns rise/fall time (1V_{pp})
- 46ns settling time to 0.1%

Applications

- Video ADC driver
- Desktop multimedia
- Single supply cable driver
- Instrumentation
- Video cards
- Wireless IF amplifiers
- Telecommunications

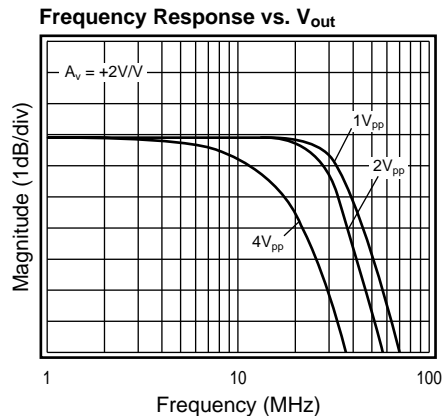

Typical Application Single +5V Supply operation

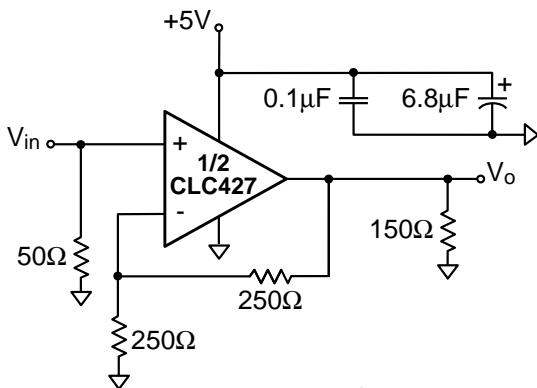

NOTE: V_{in} = 0.15V to 2.3V

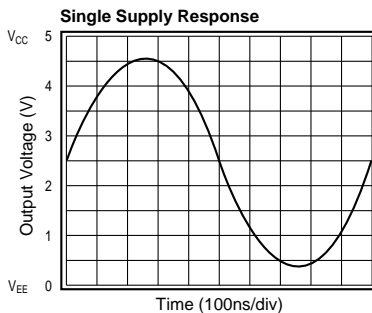

Pinout DIP & SOIC

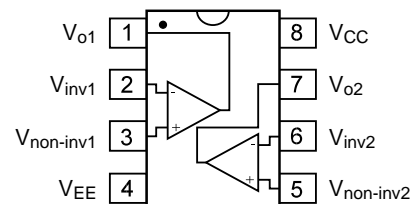

Electrical Characteristics ($V_s = +5V^1$, $V_{cm} = +2.5V$, $A_v = +2$, $R_f = 250\Omega$, $R_L = 150\Omega$ to GND; unless specified)

PARAMETERS	CONDITIONS	TYP	MIN/MAX RATINGS			UNITS	NOTES
			25°	0° to +70°	-40° to +85°		
	CLC427AJ	25°	25°	0° to +70°	-40° to +85°		
FREQUENCY DOMAIN RESPONSE							
-3dB bandwidth	$V_o < 1.0V_{pp}$	48	32	28	27	MHz	B
-3dB bandwidth	$V_o < 3.0V_{pp}$	26	16	14	11	MHz	
-3dB bandwidth $A_v = +1V/V$	$V_o < 1.0V_{pp}$	94				MHz	
rolloff	<10MHz	0.1	0.5	0.7	0.8	dB	B
peaking	DC to 200MHz	0	0.5	0.7	0.8	dB	B
linear phase deviation	<15MHz	0.3	0.6	0.8	0.9	deg	
differential gain	NTSC, $R_L=150\Omega$	0.35	0.7	-	-	%	2
differential phase	NTSC, $R_L=150\Omega$	0.55	2	-	-	deg	2
TIME DOMAIN RESPONSE							
rise and fall time	1V step	7.5	13	14	16	ns	
settling time to 0.1%	1V step	46	70	-	-	ns	
overshoot	1V step	5	13	-	-	%	
slew rate $A_v = +2$	2V step	150	90	83	65	V/ μ s	
DISTORTION AND NOISE RESPONSE							
2 nd harmonic distortion	$1V_{pp}$, 1MHz	74	-	-	-	-dBc	
	$1V_{pp}$, 5MHz	62	55	52	52	-dBc	B
3 rd harmonic distortion	$1V_{pp}$, 1MHz	94	-	-	-	-dBc	
	$1V_{pp}$, 5MHz	75	65	63	62	-dBc	B
equivalent input noise							
voltage	>1MHz	10	12.5	13.6	14	nV/ $\sqrt{\text{Hz}}$	
current	>1MHz	4	5	5.5	5.7	pA/ $\sqrt{\text{Hz}}$	
crosstalk, input referred	10MHz	65	59	59	59	-dB	
STATIC DC PERFORMANCE							
input offset voltage		2	7	8	10	mV	A
average drift		4	-	22	35	μ V/ $^{\circ}$ C	
input bias current		17	30	36	45	μ A	A
average drift		80	-	145	175	nA/ $^{\circ}$ C	
input offset current		0.2	5	6	7.5	μ A	
average drift		10	-	22	27	nA/ $^{\circ}$ C	
power supply rejection ratio	DC	82	65	64	60	dB	B
common-mode rejection ratio	DC	82	55	53	50	dB	
supply current (per amplifier)	no load	7	8.5	8.5	8.5	mA	A
MISCELLANEOUS PERFORMANCE							
input capacitance		1	2	2	2	pF	
input resistance		700	500	450	360	k Ω	
output impedance	@DC	0.07	0.15	0.24	0.7	Ω	
input voltage range, high		3.7	3.45	3.25	3.15	V	
input voltage range, low		0	0	0	0	V	
output voltage range, high	$R_L = 150\Omega$	4.5	4.35	4.3	4.2	V	
output voltage range, low	$R_L = 150\Omega$	0.35	0.5	0.5	0.55	V	
output voltage range, high	no load	4.8	4.6	4.55	4.45	V	
output voltage range, low	no load	0.45	0.65	0.7	0.75	V	
output current	source	60	50	40	34	mA	
output current	sink	36	20	16	10	mA	
supply voltage, maximum			7	7	7	V	1
supply voltage, minimum			4	4	4	V	1

transistor count = 124

Min/max ratings are based on product characterization and simulation. Individual parameters are tested as noted. Outgoing quality levels are determined from tested parameters.

Absolute Maximum Ratings

supply voltage (V_s)	+7V
I_{out} is short circuit protected to ground	
common-mode input voltage	V_{EE} to V_{CC}
maximum junction temperature	+175 $^{\circ}$ C
storage temperature range	-65 $^{\circ}$ C to +150 $^{\circ}$ C
lead temperature (soldering 10 sec)	+260 $^{\circ}$ C
differential input voltage	\pm 2V
ESD tolerance (Note 3)	2000V

Notes

- A) J-level: spec is 100% tested at 25 $^{\circ}$ C, sample tested at 85 $^{\circ}$ C.
- B) J-level: spec is sample tested at 25 $^{\circ}$ C.
- 1) $V_s = V_{CC} - V_{EE}$.
- 2) Tested with R_L tied to +2.5V.
- 3) Human body model, 1.5k Ω in series with 100pF.

Typical Performance Characteristics ($V_S = +5V^1$, $V_{CM} = +2.5V$, $A_V = +2$, $R_T = 250\Omega$, $R_L = 150\Omega$ to GND; unless specified)

Non-Inverting Frequency Response

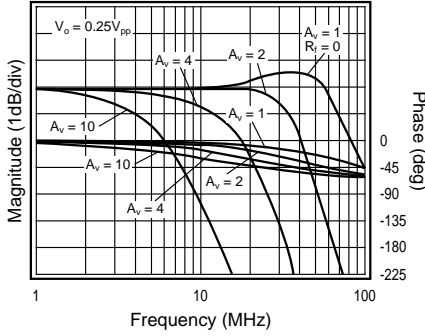

Inverting Frequency Response

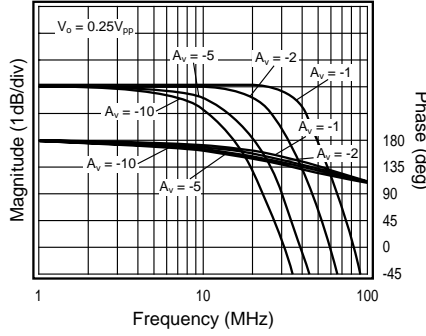

Frequency Response vs. R_L

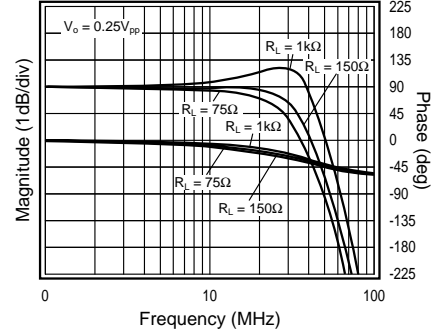

Frequency Response vs. V_{out}

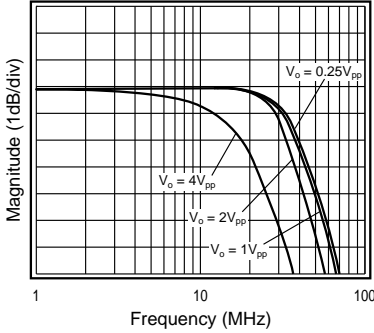

Frequency Response vs. C_L

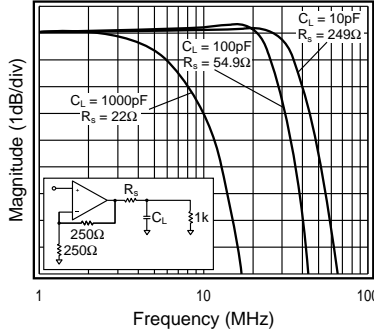

Open Loop Gain & Phase

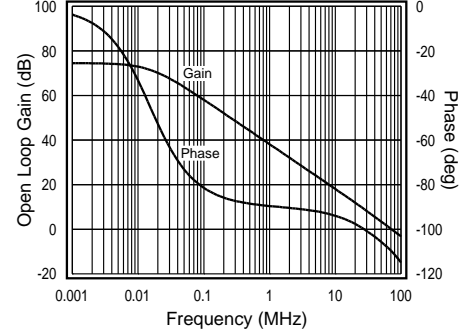

Harmonic Distortion vs. Frequency

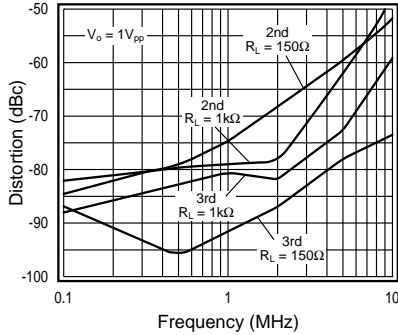

2nd Harmonic Distortion vs. V_{out}

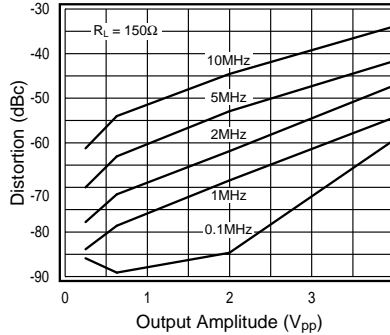

3rd Harmonic Distortion vs. V_{out}

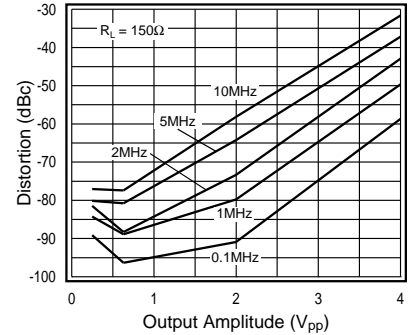

Small Signal Pulse Response

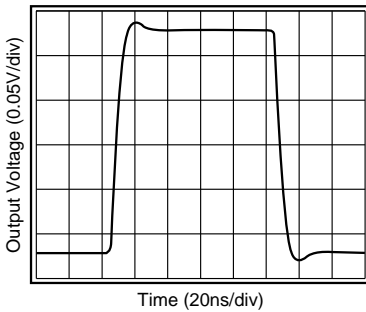

Large Signal Pulse Response

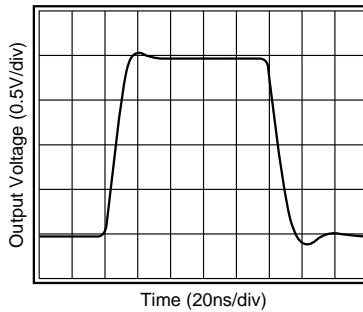

Equivalent Input Noise

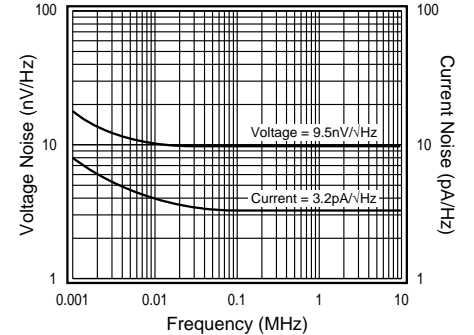

I_B, V_{IO} , vs. Temperature

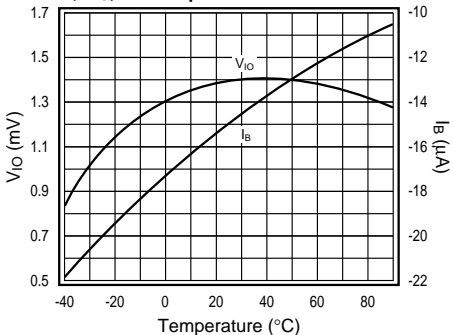

Differential Gain and Phase (3.58MHz)

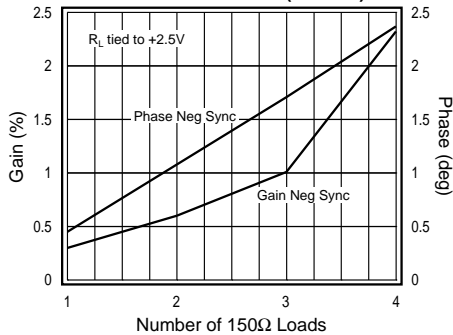

PSRR, CMRR & Linear R_{out} vs. Frequency

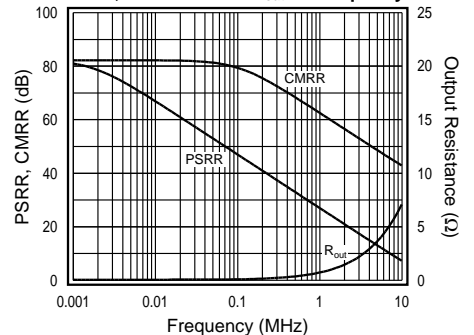

CLC427 OPERATIONS

Description

The CLC427 contains two single supply voltage-feedback amplifiers. The CLC427 is a dual version of the CLC423 with the following features:

- Operates from a single +5V supply
- Maintains near rail-to-rail performance
- Includes the negative rail (0V) in the Common Mode Input Range (CMIR)
- Offers low -74/-94dBc 2nd and 3rd harmonic distortion
- Provides BW > 20MHz and 1MHz distortion < -50dBc at $V_o = 4V_{pp}$

Single Supply Operation ($V_{CC} = +5V, V_{EE} = GND$)

The CLC427 is designed to operate from 0 and 5V supplies. The specifications given in the **Electrical Characteristics** table are measured with a common mode voltage (V_{cm}) of 2.5V. V_{cm} is the voltage around which the inputs are applied and the output voltages are specified.

Operating from a single +5V supply, the CMIR of the CLC427 is typically 0V to +3.7V. The typical output range with $R_L = 150\Omega$ is +0.35V to +4.5V.

For simple single supply operation, it is recommended that input signal levels remain above ground. For input signals that drop below ground, AC coupling and level shifting the signal are possible remedies. For input signals that remain above ground, no adjustments need to be made. The non-inverting and inverting configurations for both input conditions are illustrated in the following 2 sections.

Standard Single Supply Operation

Figures 1 and 2 show the recommended non-inverting and inverting configurations for purely positive input signals.

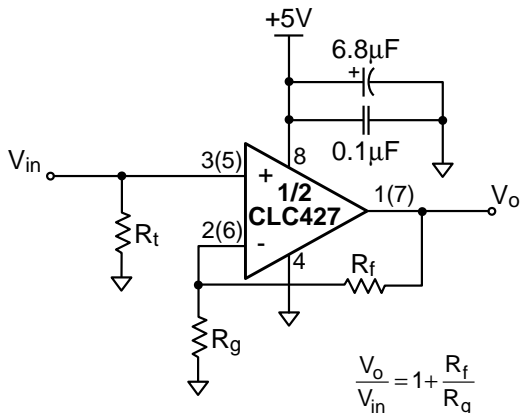

Figure 1: Non-inverting Configuration

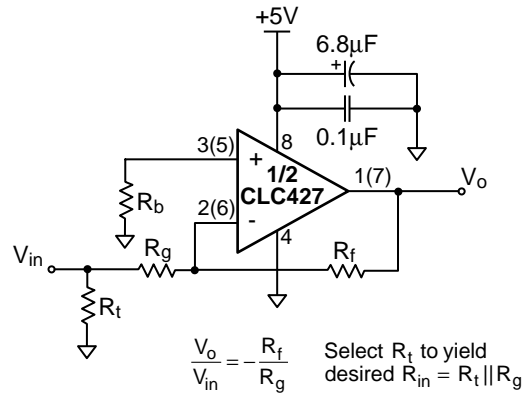

Figure 2: Inverting Configuration

Single Supply Operation for Inputs that go below 0V

Figures 3 and 4 show possible non-inverting and inverting configurations for input signals that go below ground. The input is AC coupled to prevent the need for level shifting the input signal at the source. The resistive voltage divider biases the non-inverting input to $V_{CC} \div 2 = 2.5V$.

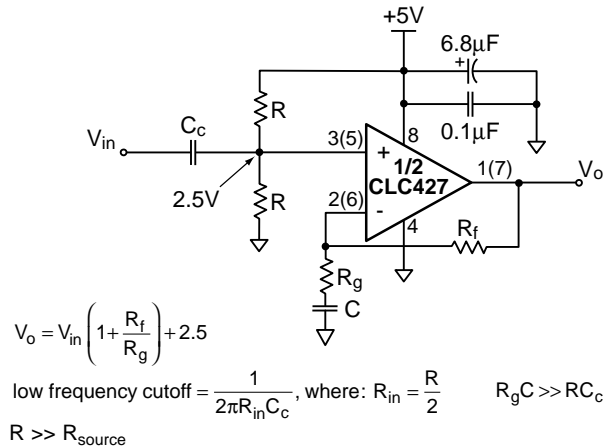

Figure 3: AC Coupled Non-inverting Configuration

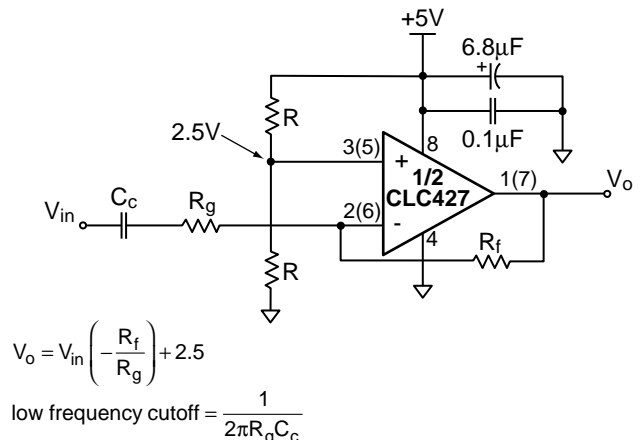

Figure 4: AC Coupled Inverting Configuration

Load Termination

Since the CLC427 design has been optimized for Single Supply Operation, it is more capable of sourcing rather than sinking current. For optimum performance, the load should be tied to V_{EE} . When the load is tied to V_{EE} , the output always sources current.

Output Overdrive Recovery

When the output range of an amplifier is exceeded, time is required for the amplifier to recover from this overdriven condition. Figure 5 illustrates the overload recovery of the CLC427 when the output is overdriven. An input was applied in an attempt to drive the output to twice the supply rails, $V_{CC} - V_{EE} = 10V$, but the output limits. An inverting gain topology was used, see Figure 2. As indicated, the CLC427 recovers within 25ns on the rising edge and within 10ns on the falling edge.

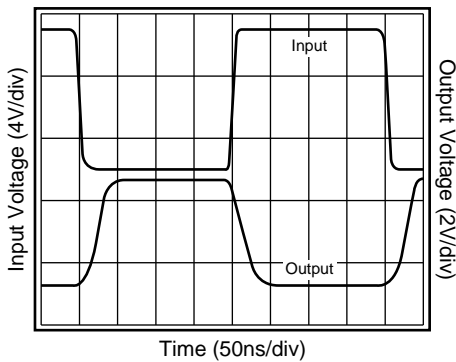

Figure 5: Overdrive Recovery

Channel Matching

Channel matching and crosstalk rejection are largely dependent on board layout. The layout of Comlinear's dual amplifier evaluation boards are designed to produce optimum channel matching and isolation. Channel matching for the CLC427 is shown in Figure 6.

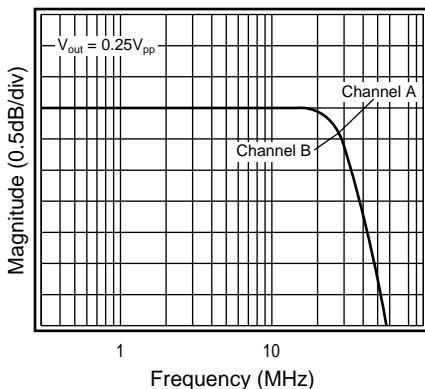

Figure 6: Channel Matching

The CLC427's channel-to-channel isolation is better than -70dB for video frequencies of 4MHz. Input referred crosstalk vs frequency is illustrated in Figure 7. Pulsed crosstalk is shown in Figure 8.

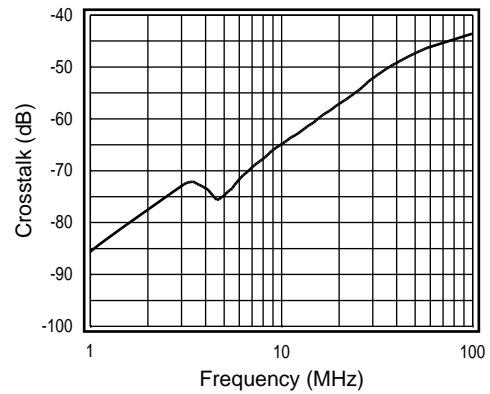

Figure 7: Input Referred Crosstalk vs. Frequency

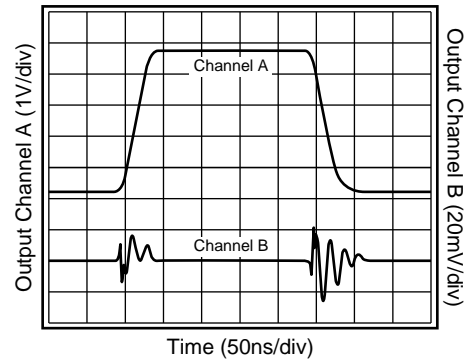

Figure 8: Pulsed crosstalk

Driving Cables and Capacitive Loads

When driving cables, double termination is used to prevent reflections. For capacitive load applications, a small series resistor at the output of the CLC427 will improve stability. The **Frequency Response vs. Capacitive Load** plot, in the typical performance section, gives the recommended series resistance value for optimum flatness at various capacitive loads.

Power Dissipation

The power dissipation of an amplifier can be described in two conditions:

- Quiescent Power Dissipation - P_Q (No Load Condition)
- Total Power Dissipation - P_T (with Load Condition)

The following steps can be taken to determine the power consumption for each CLC427 amplifier:

1. Determine the quiescent power
 $P_Q = I_{CC} (V_{CC} - V_{EE})$
2. Determine the RMS power at the output stage
 $P_O = (V_{CC} - V_{load}) (I_{load})$
3. Determine the total RMS power
 $P_T = P_Q + P_O$

Add the total RMS powers for both channels to determine the power dissipated by the dual.

The maximum power that the package can dissipate at a given temperature is illustrated in the **Power Derating** curves in the **Typical Performance** section. The power derating curve for any package can be derived by utilizing the following equation:

$$\frac{(175^\circ - T_{amb})}{\theta_{JA}}$$

where: T_{amb} = Ambient temperature (°C)
 θ_{JA} = Thermal resistance, from junction to ambient, for a given package (°C/W)

Layout Considerations

A proper printed circuit layout is essential for achieving high frequency performance. Comlinear provides evaluation boards for the CLC427 (730038 - DIP, 730036-SOIC) and suggests their use as a guide for high frequency layout and as an aid for device testing and characterization.

General layout and supply bypassing play major roles in high frequency performance. Follow the steps below as a basis for high frequency layout:

1. Include 6.8µF tantalum and 0.1µF ceramic capacitors on both supplies.
2. Place the 6.8µF capacitors within 0.75 inches of the power pins.
3. Place the 0.1µF capacitors within 0.1 inches of the power pins.
4. Remove the ground plane under and around the part, especially near the input and output pins to reduce parasitic capacitance.
5. Minimize all trace lengths to reduce series inductances.

Additional information is included in the evaluation board literature.

Applications Circuits

Typical Application Circuit

The typical application shown on the front page illustrates the near rail-to-rail performance of the CLC427.

Multiple Feedback Bandpass Filter

Figure 9 illustrates a bandpass filter and design equations. The circuit operates from a single supply of +5V. The voltage divider biases the non-inverting input to 2.5V. The input is AC coupled to prevent the need for level shifting the input signal at the source. Use the design equations to determine R_1 and R_2 based on the desired Q and center frequency.

This example illustrates a bandpass filter with $Q = 4$ and center frequency $f_c = 1\text{MHz}$. Figure 10 indicates the filter response.

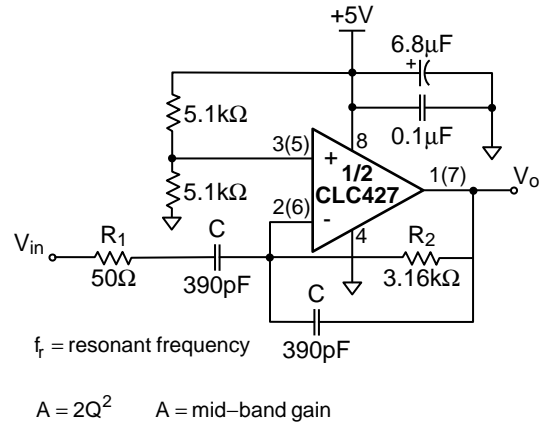

Figure 9: Bandpass Filter Topology

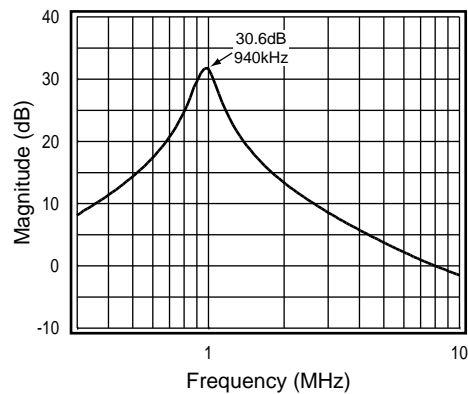

Figure 10: Bandpass Response

Distribution Amplifier

Figure 11 illustrates a distribution amplifier. The topology utilizes the dual amplifier package. The input is AC coupled and the non-inverting terminals of both amplifiers are biased at 2.5V.

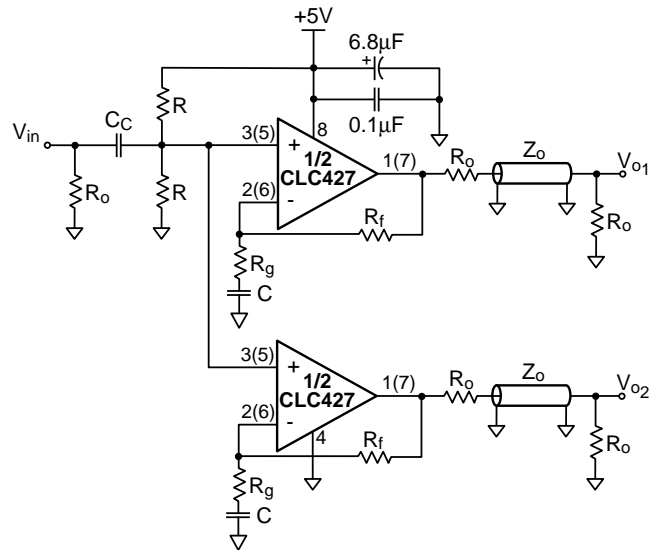

Figure 11: Distribution Amplifier

DC Coupled Single-to-Differential Converter

A DC coupled single-to-differential converter is illustrated in Figure 12.

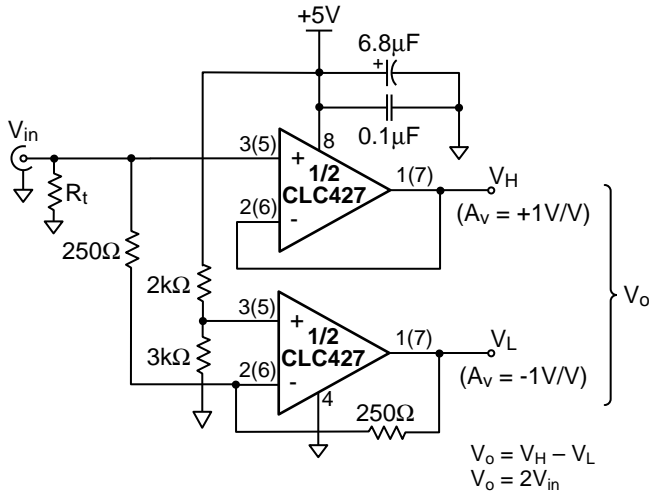

Figure 12: Single-to-Differential Converter

Ordering Information

Model	Temperature Range	Description
CLC427AJP	-40°C to +85°C	8-pin PDIP
CLC427AJE	-40°C to +85°C	8-pin SOIC

Package Thermal Resistance

Package	θ_{JC}	θ_{JA}
Plastic (AJP)	75°/W	90°/W
Surface Mount (AJE)	90°/W	115°/W

Customer Design Applications Support

National Semiconductor is committed to design excellence. For sales, literature and technical support, call the National Semiconductor Customer Response Group at **1-800-272-9959** or fax **1-800-737-7018**.

Life Support Policy

National's products are not authorized for use as critical components in life support devices or systems without the express written approval of the president of National Semiconductor Corporation. As used herein:

1. Life support devices or systems are devices or systems which, a) are intended for surgical implant into the body, or b) support or sustain life, and whose failure to perform, when properly used in accordance with instructions for use provided in the labeling, can be reasonably expected to result in a significant injury to the user.
2. A critical component is any component of a life support device or system whose failure to perform can be reasonably expected to cause the failure of the life support device or system, or to affect its safety or effectiveness.



National Semiconductor Corporation

1111 West Bardin Road
Arlington, TX 76017
Tel: 1(800) 272-9959
Fax: 1(800) 737-7018

National Semiconductor Europe

Fax: (+49) 0-180-530 85 86
E-mail: europe.support.nsc.com
Deutsch Tel: (+49) 0-180-530 85 85
English Tel: (+49) 0-180-532 78 32
Francais Tel: (+49) 0-180-532 93 58
Italiano Tel: (+49) 0-180-534 16 80

National Semiconductor Hong Kong Ltd.

13th Floor, Straight Block
Ocean Centre, 5 Canton Road
Tsimshatsui, Kowloon
Hong Kong
Tel: (852) 2737-1600
Fax: (852) 2736-9960

National Semiconductor Japan Ltd.

Tel: 81-043-299-2309
Fax: 81-043-299-2408

National does not assume any responsibility for use of any circuitry described, no circuit patent licenses are implied and National reserves the right at any time without notice to change said circuitry and specifications.