

DS14C238 Single Supply TIA/EIA-232 4 x 4 Driver/Receiver

General Description

The DS14C238 is a four driver, four receiver device which conforms to the TIA/EIA-232-E standard and CCITT V.28 recommendations. This device eliminates $\pm 12V$ supplies by employing an internal DC-DC converter to generate the necessary output levels from a single +5V supply. Driver slew rate control and receiver noise filtering have also been internalized to eliminate the need for external slew rate control and noise filtering capacitors.

The combination of its extended operating temperature range and low power requirement makes this device an ideal choice for a wide variety of commercial, industrial, and battery powered applications.

Features

- Conforms to TIA/EIA-232-E and CCITT V.28
- Internal DC-DC converter
- Operates with single +5V supply
- Low power requirement— I_{CC} 10 mA max
- Internal driver slew rate control
- Receiver noise filtering
- Operates above 120 kbits/sec
- Direct replacement for MAX238
- Industrial temperature range option—DS14C238T ($-40^{\circ}C$ to $+85^{\circ}C$)

Connection Diagram

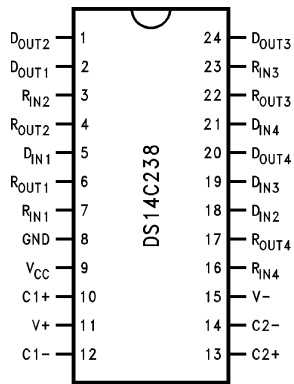

TL/F/11282-1

Order Number DS14C238N, DS14C238WM,
DS14C238TN or DS14C238TWM
See NS Package Numbers M24B or NA24G

Functional Diagram

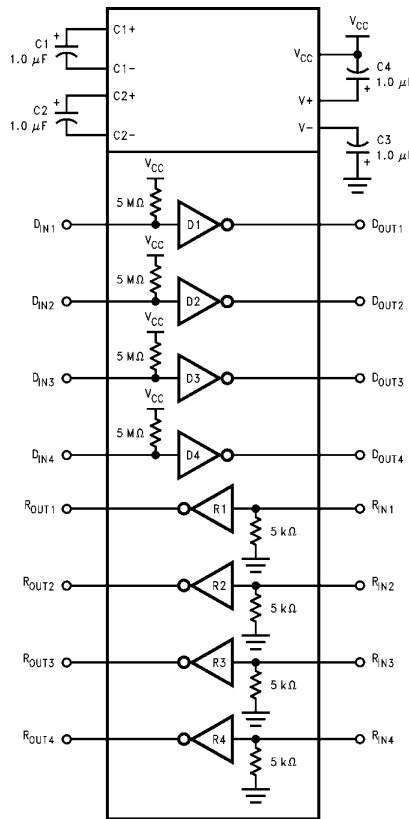

TL/F/11282-2

DS14C238 Single Supply TIA/EIA-232 4 x 4 Driver/Receiver

Absolute Maximum Ratings

If Military/Aerospace specified devices are required, please contact the National Semiconductor Sales Office/Distributors for availability and specifications.

Supply Voltage (V_{CC})	-0.3V to +6V
V+ Pin	($V_{CC} - 0.3V$) to +15V
V- Pin	+0.3V to -15V
Driver Input Voltage	-0.3V to ($V_{CC} + 0.3V$)
Driver Output Voltage	(V+ +0.3V) to (V- -0.3V)
Receiver Input Voltage	±30V
Receiver Output Voltage	-0.3V to ($V_{CC} + 0.3V$)
Junction Temperature	+150°C
Maximum Package Power Dissipation @ +25°C (Note 6)	
N Package	2400 mW
WM Package	1400 mW

Storage Temp. Range	-65°C to +150°C
Lead Temp. (Soldering, 4 Seconds)	+260°C
Short Circuit Duration (D_{OUT})	Continuous
ESD Rating (HBM, 1.5 kΩ, 100 pF)	≥ 2.0 kV

Recommended Operating Conditions

	Min	Max	Units
Supply Voltage, V_{CC}	4.5	5.5	V
Operating Free Air Temp. (T_A)			
DS14C238	0	+70	°C
DS14C238T	-40	+85	°C

Electrical Characteristics

Over recommended operating conditions, unless otherwise specified. (Note 2)

Symbol	Parameter	Conditions	Min	Typ	Max	Units
DEVICE CHARACTERISTICS						
V+	Positive Power Supply	$R_L = 3\text{ k}\Omega$, $C_1 - C_4 = 1.0\text{ }\mu\text{F}$, $D_{IN} = 0.8V$		9.0		V
V-	Negative Power Supply	$R_L = 3\text{ k}\Omega$, $C_1 - C_4 = 1.0\text{ }\mu\text{F}$, $D_{IN} = 2.0V$		-8.0		V
I_{CC}	Supply Current (V_{CC})	No Load		7.0	10	mA
DRIVER CHARACTERISTICS						
V_{IH}	High Level Input Voltage		2.0		V_{CC}	V
V_{IL}	Low Level Input Voltage		GND		0.8	V
I_{IH}	High Level Input Current	$V_{IN} \geq 2.0V$	-10		+10	μA
I_{IL}	Low Level Input Current	$V_{IN} \leq 0.8V$	-10		+10	μA
V_{OH}	High Level Output Voltage	$R_L = 3\text{ k}\Omega$	5.0	7.4		V
V_{OL}	Low Level Output Voltage			-6.3	-5.0	V
I_{OS+}	Output High Short Circuit Current	$V_O = 0V$, $V_{IN} = 0.8V$	-30	-15	-5.0	mA
I_{OS-}	Output Low Short Circuit Current	$V_O = 0V$, $V_{IN} = 2.0V$				
R_O	Output Resistance	$-2V \leq V_O \leq +2V$, $V_{CC} = \text{GND} = 0V$	300			Ω

Electrical Characteristics (Continued)

Over recommended operating conditions, unless otherwise specified. (Note 2)

Symbol	Parameter	Conditions	Min	Typ	Max	Units
RECEIVER CHARACTERISTICS						
V _{TH}	Input High Threshold Voltage			1.9	2.4	V
V _{TL}	Input Low Threshold Voltage		0.8	1.5		V
V _{HY}	Hysteresis		0.2	0.4	1.0	V
R _{IN}	Input Resistance		3.0	4.5	7.0	kΩ
I _{IN}	Input Current	V _{IN} = +15V	2.14	3.8	5.0	mA
		V _{IN} = +3V	0.43	0.6	+1.0	mA
		V _{IN} = -3V	-1.0	-0.6	-0.43	mA
		V _{IN} = -15V	-5.0	-3.8	-2.14	mA
V _{OH}	High Level Output Voltage	V _{IN} = -3V, I _O = -3.2 mA	3.5	4.5		V
		V _{IN} = -3V, I _O = -20 μA	4.0	4.9		V
V _{OL}	Low Level Output Voltage	V _{IN} = +3V, I _O = +3.2 mA		0.25	0.4	V

Switching Characteristics

Over recommended operating conditions, unless otherwise specified. (Note 4)

Symbol	Parameter	Conditions	Min	Typ	Max	Units
DRIVER CHARACTERISTICS						
t _{PLH}	Propagation Delay LOW to HIGH	R _L = 3 kΩ C _L = 50 pF (Figures 1 and 2)		0.7	4.0	μs
t _{PHL}	Propagation Delay HIGH to LOW			0.6	4.0	μs
t _{sk}	Skew t _{PLH} - t _{PHL}				0.1	1.0
SR1	Output Slew Rate	R _L = 3kΩ to 7 kΩ, C _L = 50 pF	4.0	15	30	V/μs
SR2	Output Slew Rate	R _L = 3 kΩ, C _L = 2500 pF	3.0	5.0		V/μs
RECEIVER CHARACTERISTICS						
t _{PLH}	Propagation Delay LOW to HIGH	Input Pulse Width > 10 μs C _L = 50 pF		2.0	6.5	μs
t _{PHL}	Propagation Delay HIGH to LOW			2.8	6.5	μs
t _{SK}	Skew t _{PLH} - t _{PHL}	(Figures 3 and 4)		0.8	2.0	μs
t _{NW}	Noise Pulse Width Rejected	(Figures 3 and 4)		2.5	1.0	μs

Note 1: "Absolute Maximum Ratings" are those values beyond which the safety of the device cannot be guaranteed. They are not meant to imply that the devices should be operated at these limits. The tables of "Electrical Characteristics" specify conditions for device operation.

Note 2: Current into device pins is defined as positive. Current out of device pins is defined as negative. All voltages are referenced to ground unless otherwise specified.

Note 3: I_{OS+} and I_{OS-} values are for one output at a time. If more than one output is shorted simultaneously, the device power dissipation may be exceeded.

Note 4: Receiver AC input waveform for test purposes: t_r = t_f = 200 ns, V_{IH} = 3V, V_{IL} = -3V, f = 64 kHz (128 kbits/sec). Driver AC input waveform for test purposes: t_r = t_f ≤ 10 ns, V_{IH} = 3V, V_{IL} = 0V, f = 64 kHz (128 kbits/sec).

Note 5: All typicals are given for V_{CC} = 5.0V and T_A = +25°C.

Note 6: Ratings apply to ambient temperature at +25°C. Above this temperature derate: N package 20 mW/°C and WM package 13.5 mW/°C.

Parameter Measurement Information

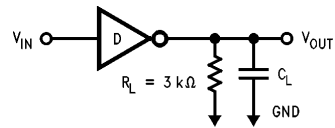

TL/F/11282-4

FIGURE 1. Driver Load Circuit

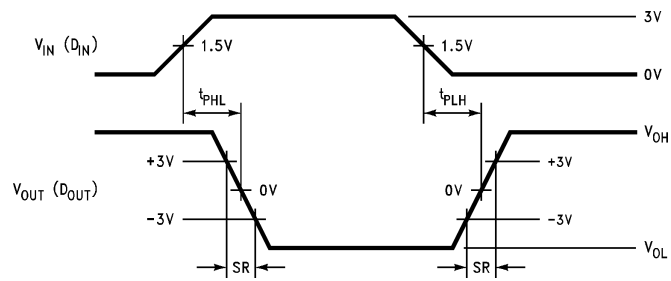

TL/F/11282-5

FIGURE 2. Driver Switching Waveform

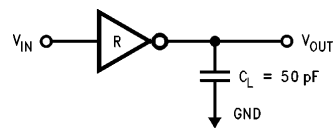

TL/F/11282-6

FIGURE 3. Receiver Load Circuit

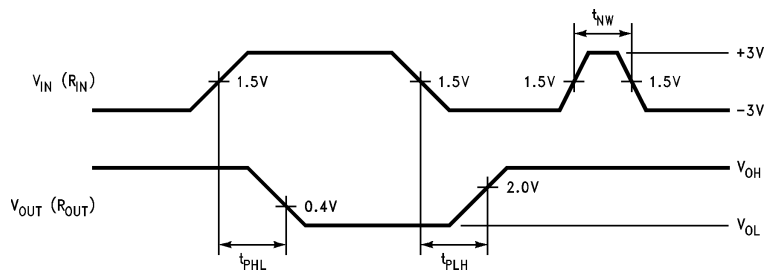

TL/F/11282-7

FIGURE 4. Receiver Propagation Delays and Noise Rejection

Pin Descriptions

V_{CC} (pin 9)—Power supply pin for the device, +5V ($\pm 10\%$).

V₊ (pin 11)—Positive supply for TIA/EIA-232-E drivers. Recommended external capacitor: C4 = 1.0 μ F (6.3V). This supply is not intended to be loaded externally.

V₋ (pin 15)—Negative supply for TIA/EIA-232-E drivers. Recommended external capacitor: C3 = 1.0 μ F (16V). This supply is not intended to be loaded externally.

C1₊, C1₋ (pins 10 and 12)—External capacitor connection pins. Recommended capacitor – 1.0 μ F (6.3V).

C2₊, C2₋ (pins 13 and 14)—External Capacitor connection pins. Recommended capacitor – 1.0 μ F (16V).

D_{IN} 1–5 (pins 7, 6, 8, 18, 19, and 21)—Driver input pins are TTL/CMOS compatible. Inputs of unused drivers may be

left open, an internal pull-up resistor (500 k Ω minimum, typically 5 M Ω) pulls input to V_{CC}. Output will be LOW for open inputs.

D_{OUT} 1–5 (pins 2, 3, 1, 24, and 20)—Driver output pins conform to TIA/EIA-232-E levels.

R_{IN} 1–3 (pins 4, 23, and 16)—Receiver input pins accept TIA/EIA-232-E input voltages (± 15 V). Receivers feature a noise filter and guaranteed hysteresis of 200 mV. Unused receiver input pins may be left open. Internal input resistor (5 k Ω) pulls input LOW, providing a failsafe HIGH output.

R_{OUT} 1–3 (pins 5, 22, and 17)—Receiver output pins are TTL/CMOS compatible. Receiver output HIGH voltage is specified for both CMOS and TTL load conditions.

GND (pin 8)—Ground Pin.

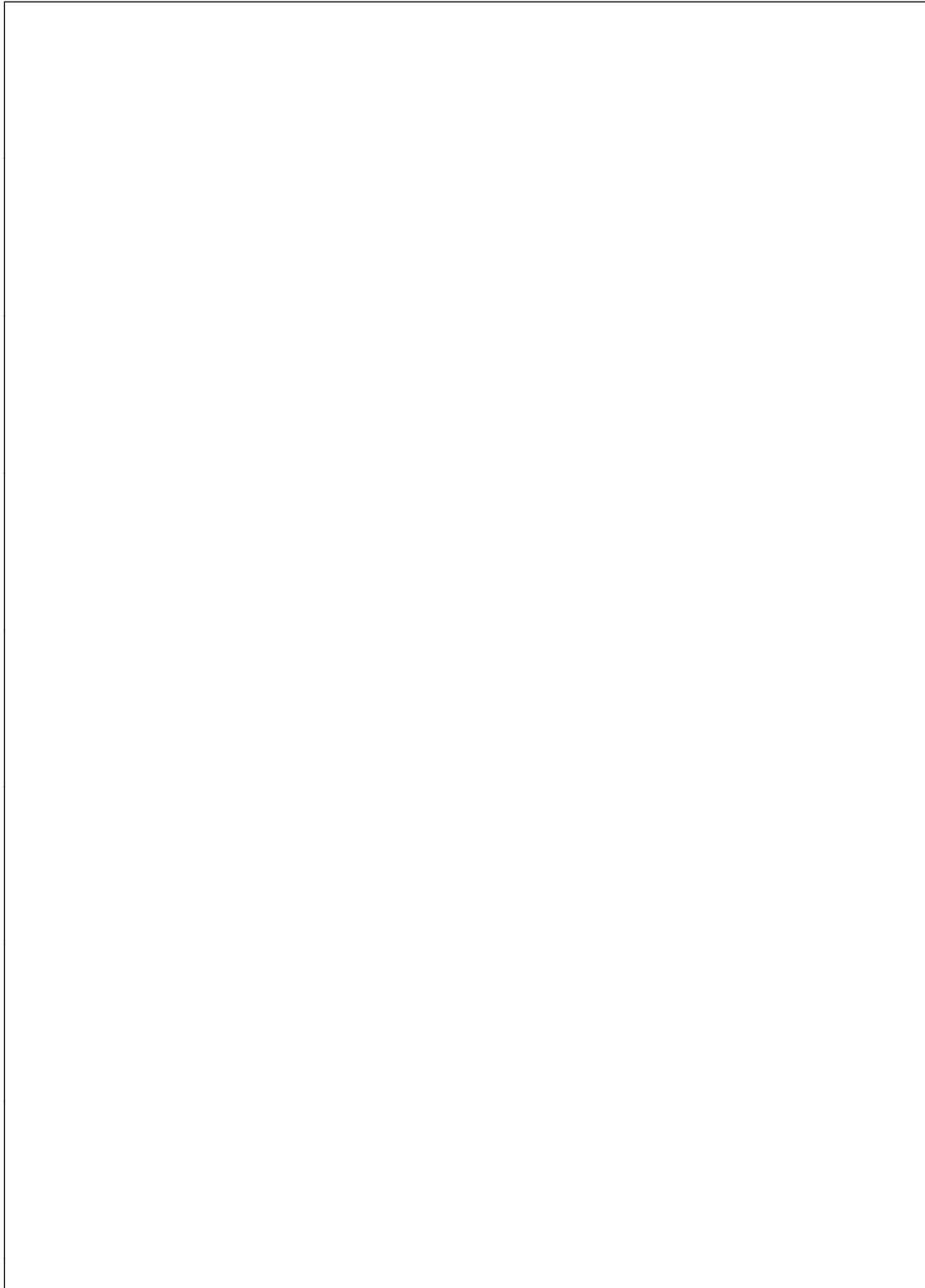

Physical Dimensions inches (millimeters) (Continued)

Lit. # 103299

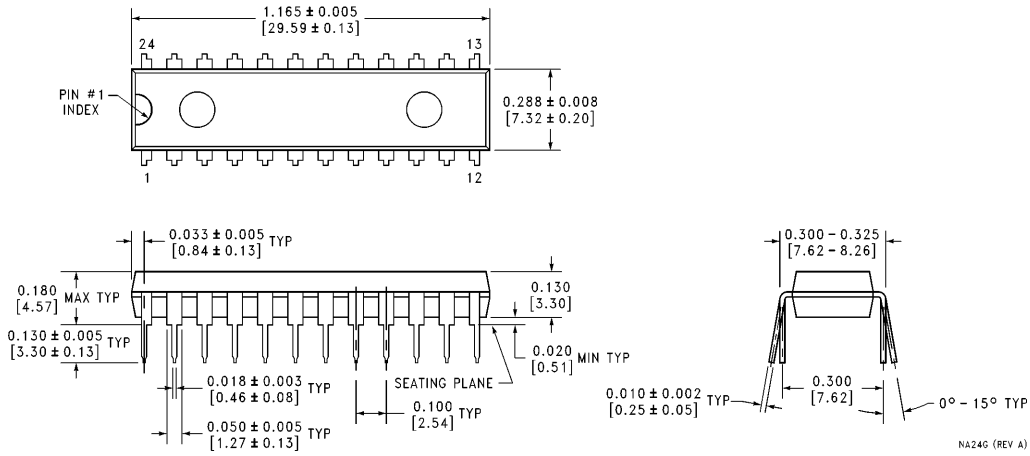

Order Number DS14C238N or DS14C238TN
NS Package Number NA24G

LIFE SUPPORT POLICY

NATIONAL'S PRODUCTS ARE NOT AUTHORIZED FOR USE AS CRITICAL COMPONENTS IN LIFE SUPPORT DEVICES OR SYSTEMS WITHOUT THE EXPRESS WRITTEN APPROVAL OF THE PRESIDENT OF NATIONAL SEMICONDUCTOR CORPORATION. As used herein:

1. Life support devices or systems are devices or systems which, (a) are intended for surgical implant into the body, or (b) support or sustain life, and whose failure to perform, when properly used in accordance with instructions for use provided in the labeling, can be reasonably expected to result in a significant injury to the user.
2. A critical component is any component of a life support device or system whose failure to perform can be reasonably expected to cause the failure of the life support device or system, or to affect its safety or effectiveness.



National Semiconductor Corporation
1111 West Bardin Road
Arlington, TX 76017
Tel: 1(800) 272-9959
Fax: 1(800) 737-7018

<http://www.national.com>

National Semiconductor Europe

Fax: +49 (0) 180-530 85 86
Email: europe.support@nsc.com
Deutsch Tel: +49 (0) 180-530 85 85
English Tel: +49 (0) 180-532 78 32
Français Tel: +49 (0) 180-532 93 58
Italiano Tel: +49 (0) 180-534 16 80

National Semiconductor Hong Kong Ltd.

19th Floor, Straight Block,
Ocean Centre, 5 Canton Rd.
Tsimshatsui, Kowloon
Hong Kong
Tel: (852) 2737-1600
Fax: (852) 2736-9960

National Semiconductor Japan Ltd.

Tel: 81-043-299-2308
Fax: 81-043-299-2408