

DS14C335 + 3.3V Supply TIA/EIA-232 3 x 5 Driver/Receiver

General Description

The DS14C335 is three driver, five receiver device which conforms to TIA/EIA-232-E and CCITT V.28 standard specifications. This device employs an internal DC-DC converter to generate the necessary output levels from a +3.3V power supply. A SHUTDOWN (SD) mode reduces the supply current to 10 μ A maximum. In the SD mode, one receiver is active, allowing ring indicator (RI) to be monitored. PC Board space consumption is minimized by the availability of Shrink Small Outline Packaging (SSOP).

This device's low power requirement and small footprint makes it an ideal choice for Laptop and Notebook applications.

Features

- Conforms to TIA/EIA-232-E and CCITT V.28 specifications
- Operates with single +3.3V power supply
- Low power requirement— I_{CC} 20 mA maximum
- SHUTDOWN mode— I_{CX} 10 μ A maximum
- One Receiver (R5) active during SHUTDOWN
- Operates up to 128 kbps—Lap-Link® Compatible
- Flow through pinout
- 4V/ μ s minimum Slew Rate guaranteed
- Inter-operates with +5V UARTs
- Available in 28-lead SSOP EIAJ Type II package

Connection Diagram

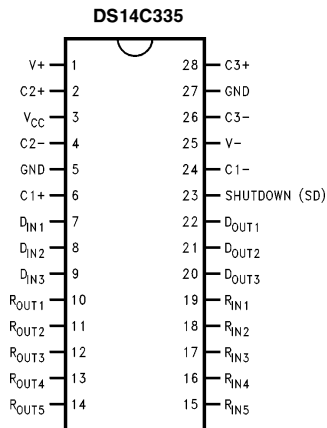

TL/F/11734-1

Order Number **DS14C335MSA** or
DS14C335TMSA
See NS Package Number **MSA28**

Functional Diagram

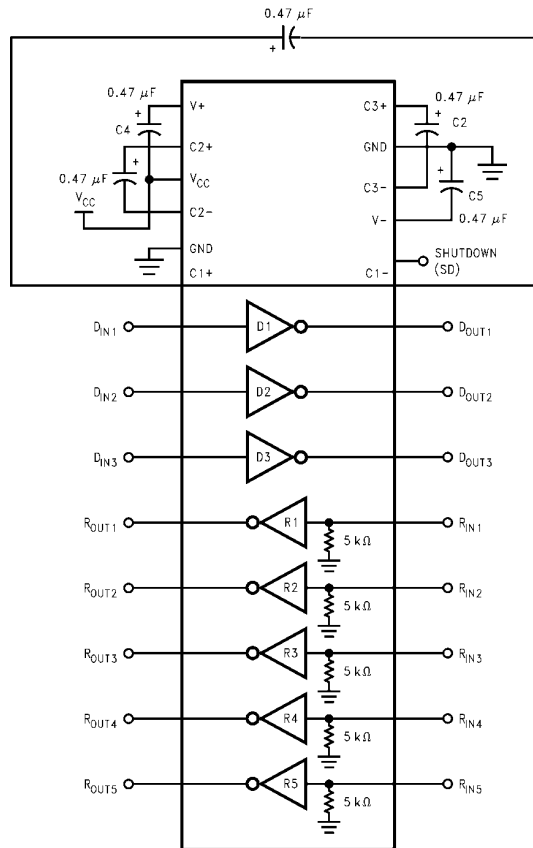

TL/F/11734-2

Lap-Link® is a registered trademark of Traveling Software.

Absolute Maximum Ratings (Note 1)

If Military/Aerospace specified devices are required, please contact the National Semiconductor Sales Office/Distributors for availability and specifications.

Supply Voltage (V_{CC})	-0.3V to +6V
V^+ Pin	($V_{CC} - 0.3V$) to +14V
V^- Pin	+0.3V to -14V
Input Voltage (DIN, SD)	-0.3V to +5.5V
Driver Output Voltage	($V^+ + 0.3V$) to ($V^- - 0.3V$)
Receiver Input Voltage	$\pm 25V$
Receiver Output Voltage	-0.3V to ($V_{CC} + 0.3V$)
Junction Temperature	+150°C
Storage Temperature Range	-65°C to +150°C
Lead Temperature (Soldering 4 sec.)	+260°C
Short Circuit Duration (D_{OUT})	continuous
Maximum Package Power Dissipation @ +25°C	
SSOP MSA Package	1286 mW
Derate MSA Package	10.3 mW/°C above +25°C
ESD Rating (HBM, 1.5 k Ω , 100 pF)	≥ 2.0 kV

Recommended Operating Conditions

	Min	Max	Units
Supply Voltage (V_{CC})	3.0	3.6	V
DC-DC Converter Capacitors (C1-C5)	0.47		μF
Operating Free Air Temperature (T_A)			
DS14C335	0	+70	°C
DS14C335T	-40	+85	°C

Electrical Characteristics

Over recommended operating conditions, SD = 0.8V, unless otherwise specified. (Notes 2, 3)

Symbol	Parameter	Conditions	Min	Typ	Max	Units	
DEVICE CHARACTERISTICS							
V^+	Positive Power Supply	No Load		+9.3		V	
V^-	Negative Power Supply	C1-C5 = 0.47 μF	$D_{IN} = 0.8V$				
			$D_{IN} = 2.0V$				
I_{CC}	Supply Current	No Load		11.5	20	mA	
I_{CX}	SHUTDOWN Supply Current	$R_L = 3$ k Ω , SD = V_{CC} , 5.5V		1.0	10	μA	
V_{IH}	High Level Enable Voltage		SD	2.0		V	
V_{IL}	Low Level Enable Voltage			GND	0.8	V	
I_{IH}	High Level Enable Current	$2.0V \leq V_{IN} \leq 5.5V$			+2.0	μA	
					+4.0	μA	
I_{IL}	Low Level Enable Current	$GND \leq V_{IN} \leq 0.8V$		-2.0		μA	
DRIVER CHARACTERISTICS							
V_{IH}	High Level Input Voltage		D_{IN}	2.0		V	
V_{IL}	Low Level Input Voltage			GND	0.8	V	
I_{IH}	High Level Input Current	$2.0V \leq V_{IN} \leq 5.5V$			+1.0	μA	
I_{IL}	Low Level Input Current	$GND \leq V_{IN} \leq 0.8V$		-1.0		μA	
V_{OH}	High Level Output Voltage	$R_L = 3$ k Ω		+5.0	+7.1	V	
V_{OL}	Low Level Output Voltage				-6.3	-5.0	
						V	
I_{OS+}	Output High Short Circuit Current	$V_O = 0V$, $V_{IN} = 0.8V$ (Note 7)		-40	-16.5	-8	mA
I_{OS-}	Output Low Short Circuit Current	$V_O = 0V$, $V_{IN} = 2.0V$ (Note 7)		6	12.3	40	mA
R_O	Output Resistance	$-2V \leq V_O \leq +2V$, $V_{CC} = GND = 0V$		300		Ω	

Electrical Characteristics (Continued)

Over recommended operating conditions, SD = 0.8V, unless otherwise specified. (Notes 2, 3)

Symbol	Parameter	Conditions	Min	Typ	Max	Units
RECEIVER CHARACTERISTICS (Note 4)						
V _{TH}	Input High Threshold Voltage	R1–R5, SD = 0.8V		1.4	2.4	V
		R5, 2.0V ≤ SD ≤ 5.5V		2.0	2.8	V
V _{TL}	Input Low Threshold Voltage	R1–R5, SD = 0.8V	0.4	1.1		V
		R5, 2.0V ≤ SD ≤ 5.5V	0.1	0.5		V
V _{HY}	Hysteresis		50	300		mV
R _{IN}	Input Resistance	V _{IN} = ±3V to ±15V	3.0	3.8	7.0	kΩ
I _{IN}	Input Current	V _{IN} = +15V	2.14		5.0	mA
		V _{IN} = +3V	0.43		1.0	mA
		V _{IN} = –3V	–1.0		–0.43	mA
		V _{IN} = –15V	–5.0		–2.14	mA
V _{OH}	High Level Output Voltage	V _{IN} = –3V, I _{OH} = –1 mA	2.4	3.1		V
		V _{IN} = –3V, I _{OH} = –100 μA	2.8	3.28		V
V _{OL}	Low Level Output Voltage	V _{IN} = +3V, I _{OL} = +2 mA		0.23	0.4	V

Switching Characteristics

Over recommended operating conditions, SD = 0.8V, unless otherwise specified. (Note 2)

Symbol	Parameter	Conditions	Min	Typ	Max	Units
DRIVER CHARACTERISTICS						
t _{PLH}	Propagation Delay LOW to HIGH	R _L = 3 kΩ C _L = 50 pF (Figures 1 and 2)	0.1	0.6	1.0	μs
t _{PHL}	Propagation Delay HIGH to LOW		0.1	0.6	1.0	μs
t _{SK}	Skew t _{PLH} - t _{PHL}			0	0.2	μs
SR1	Output Slew Rate	R _L = 3 kΩ to 7 kΩ, C _L = 50 pF (Figure 2)	4	13	30	V/μs
SR2	Output Slew Rate	R _L = 3 kΩ, C _L = 2500 pF (Figure 2)	4	10	30	V/μs
t _{PLS}	Propagation Delay LOW to SD	(Figures 5 and 6) R _L = 3 kΩ C _L = 50 pF		0.48		ms
t _{PSL}	Propagation Delay SD to LOW			1.88		ms
t _{PHS}	Propagation Delay HIGH to SD			0.62		ms
t _{PSH}	Propagation Delay SD to HIGH			1.03		ms
RECEIVER CHARACTERISTICS						
t _{PLH}	Propagation Delay LOW to HIGH	C _L = 50 pF (Figures 3 and 4)	0.1	0.4	1.0	μs
t _{PHL}	Propagation Delay HIGH to LOW		0.1	0.6	1.0	μs
t _{SK}	Skew t _{PLH} - t _{PHL}			0.2	0.8	μs
t _{PLS}	Propagation Delay LOW to SD	(Figures 7 and 8) R _L = 1 kΩ C _L = 50 pF R1 - R4 Only		0.13		μs
t _{PSL}	Propagation Delay SD to LOW			1.0		μs
t _{PHS}	Propagation Delay HIGH to SD			0.19		μs
t _{PSH}	Propagation Delay SD to HIGH			0.58		μs

Note 1: "Absolute Maximum Ratings" are those values beyond which the safety of the device cannot be guaranteed. They are not meant to imply that the devices should be operated at these limits. The tables of "Electrical Characteristics" specify conditions for device operation.

Note 2: Typical values are given for V_{CC} = 3.3V and T_A = +25°C.

Note 3: Current into device pins is defined as positive. Current out of device pins is defined as negative. All voltages are referenced to ground unless otherwise specified.

Note 4: Receiver characteristics are guaranteed for SD = 0.8V. When SD = 2.0V, receiver five (R5) is active and meets receiver parameters in SHUTDOWN (SD) mode, unless otherwise specified.

Note 5: Generator characteristics for driver input: f = 64 kHz (128 kbits/sec), t_r = t_f < 10 ns, V_{IH} = 3V, V_{IL} = 0V, duty cycle = 50%.

Note 6: Generator characteristics for receiver input: f = 64 kHz (128 kbits/sec), t_r = t_f = 200 ns, V_{IH} = 3V, V_{IL} = -3V, duty cycle = 50%.

Note 7: Only one driver output shorted at a time.

Parameter Measurement Information

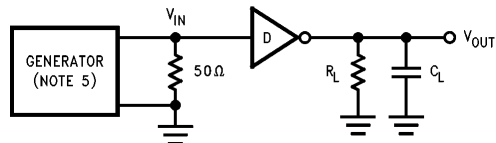

TL/F/11734-3

FIGURE 1. Driver Propagation Delay and Slew Rate Test Circuit

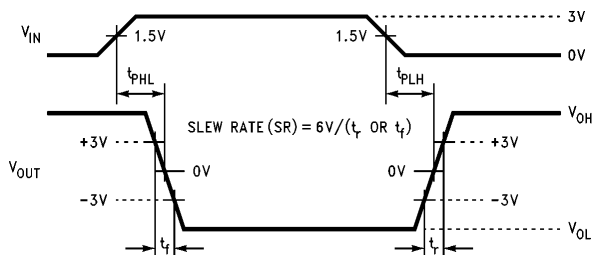

TL/F/11734-4

FIGURE 2. Driver Propagation Delay and Slew Rate Timing

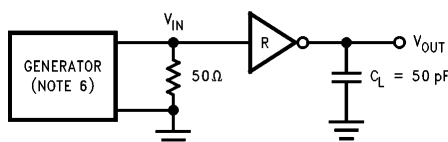

TL/F/11734-5

FIGURE 3. Receiver Propagation Delay Test Circuit

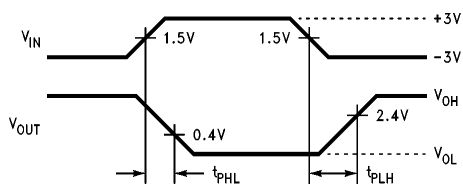

TL/F/11734-6

FIGURE 4. Receiver Propagation Delay Timing

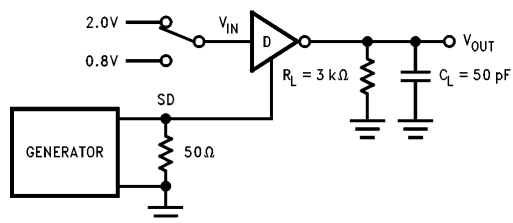

TL/F/11734-7

FIGURE 5. Driver SHUTDOWN (SD) Delay Test Circuit

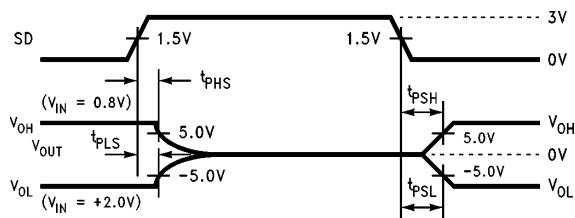

TL/F/11734-8

FIGURE 6. Driver SHUTDOWN (SD) Delay Timing

Parameter Measurement Information (Continued)

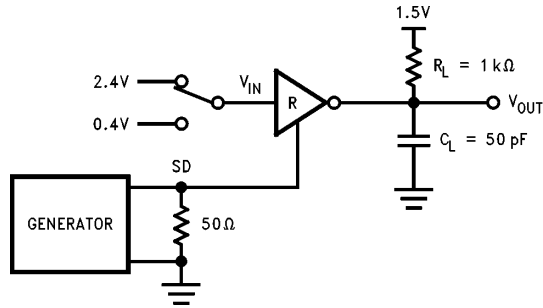

FIGURE 7. Receiver SHUTDOWN (SD) Delay Test Circuit

TL/F/11734-9

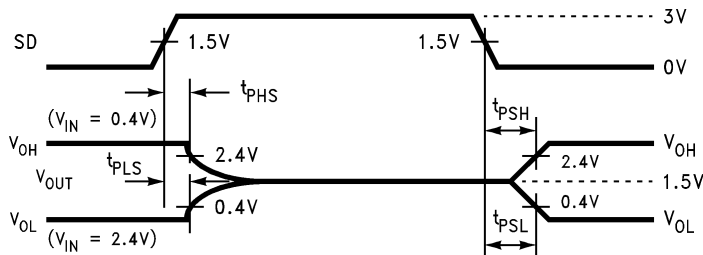

FIGURE 8. Receiver SHUTDOWN (SD) Delay Timing

TL/F/11734-10

Pin Descriptions

V_{CC} (Pin 3). Power supply pin for the device, +3.3V ($\pm 0.3V$).

V⁺ (Pin 1). Positive supply for TIA/EIA-232-E drivers. Recommended external capacitor—0.47 μF (16V). This supply is not intended to be loaded externally.

V⁻ (Pin 25). Negative supply for TIA/EIA-232-E drivers. Recommended external capacitor—0.47 μF (16V). This supply is not intended to be loaded externally.

C1+, C1- (Pins 6, 24). External capacitor connection pins. Recommended capacitor—0.47 μF (6.3V).

C2+, C2- (Pins 2, 4). External capacitor connection pins. Recommended capacitor—0.47 μF (16V).

C3+, C3- (Pins 28, 26). External capacitor connection pins. Recommended capacitor—0.47 μF (6.3V).

SHUTDOWN (SD) (Pin 23). A High on the SHUTDOWN pin will lower the total I_{CC} current to less than 10 μA , providing a low power state. In this mode receiver R5 remains active. The SD pin should be driven or tied low (GND) to disable the shutdown mode.

D_{IN} 1-3 (Pins 7, 8, 9). Driver input pins are JEDEC 3.3V standard compatible.

D_{OUT} 1-3 (Pins 22, 21, 20). Driver output pins conform to TIA/EIA-232 -E levels.

R_{IN} 1-5 (Pins 19, 18, 17, 16, 15). Receiver input pins accept TIA/EIA-232-E input voltages ($\pm 25V$). Receivers guarantees hysteresis of TBD mV. Unused receiver input pins may be left open. Internal input resistor (5 k Ω) pulls input LOW, providing a failsafe HIGH output.

R_{OUT} 1-5 (Pins 10, 11, 12, 13, 14). Receiver output pins are JEDEC 3.3V standard compatible.

GND (Pin 27). Ground Pin.

Application Information

9-Pin SERIAL PORT APPLICATION

In a typical Data Terminal Equipment (DTE) to Data Circuit-Terminating Equipment (DCE) 9-pin de-facto interface implementation, 2 data lines and 6 control lines are required. The data lines are TXD and RXD and the control lines are RTS, DTR, DSR, DCD, CTS and RI. The DS14C335 is a 3 x 5 Driver/Receiver and offers a single chip solution for the DTE interface as shown in *Figure 9*.

Ring Indicator (RI) is used to inform the DTE that an incoming call is coming from a remote DCE. When the DS14C335 is in SHUTDOWN (SD) mode, receiver five (R5) remains active and monitors RI circuit. This active receiver (R5) alerts the DTE to switch the DS14C335 from SHUTDOWN to active mode.

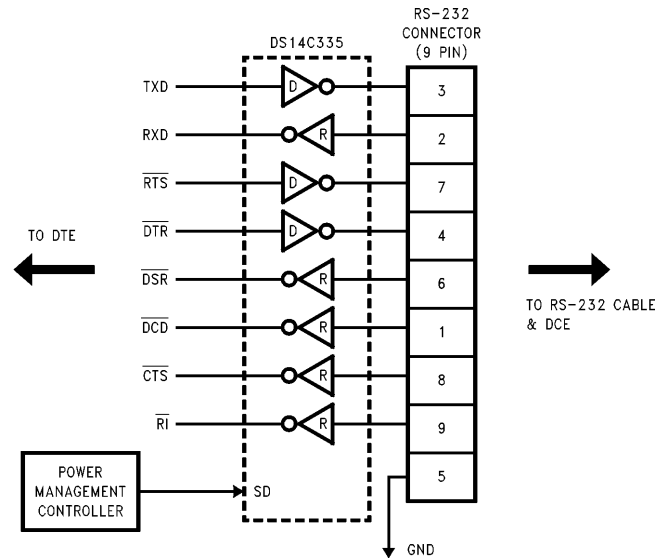

FIGURE 9. Typical DTE Application

TL/F/11734-11

Application Information (Continued)

MOUSE DRIVING

The DS14C335 was tested for drive current under the following mouse driving conditions:

- Two driver outputs set at V_{OH} and their outputs were tied together (paralleled), sourcing current to supply the $V+$ terminal of the mouse electronics
- One driver output set at V_{OL} to sink the current from the $V-$ terminal of the mouse electronics
- One receiver was used to accept data from the mouse
- Power Supply Voltage (V_{CC}): 3.0V to 3.6V

Completion of the testing (performed by National's Data Transmission Applications Group and a major PC manufacturer) concluded that the DS14C335 and its DC-DC Converter supplied adequate drive capability to power a typical PC mouse. The mouse tested was specified with the following conditions:

- 10 mA at +6V
- 5.0 mA at -6V

Since driver current is limited, it is recommended that newer lower power mice be specified for battery powered applications. Using older high power mice is wasteful of precious battery charge.

EXTERNAL DC-DC CONVERTOR COMPONENTS

The DS14C335 with its unique DC-DC Converter triples the power supply voltage (3.0V) to +9.3V and then inverts it to a -9V potential. This unique converter **ONLY** requires 5 external surface mount 0.47 μ F capacitors. The five identical components were chosen to simplify PCB layout and the procurement of components. The DS14C335's DC-DC Converter also provides a larger signal swing (higher at RS-232 standard data rates) which translates to more noise margin for the rejection of ground potential differences, induced

noise, and crosstalk compared to other DC-DC converter schemes which only provide limited signal swing and limited noise margin.

DC-DC CONVERTOR CAPACITORS

The use of polarized capacitors is not required. However, if they are used, the polarity indicated in the DS14C335 Functional Diagram must be honored for proper operation. Surface mount capacitors or ceramic capacitors may be used, however, for optimal efficiency, capacitors with a low effective series resistance (ESR) should be used. Values in the low Ohms(Ω) is normally acceptable.

INTEROPERATION WITH +5V UARTS

The DS14C335 provides full RS-232 driver output levels and a single chip solution for the popular 9-pin defacto serial port. This device may be used in either pure +3V applications or mixed power supplied +3V/ +5V applications. The Driver Input (DIN) and ShutDown (SD) input pins can directly accept full +5V levels without the need for any external components. The Receiver Output (ROUT) is specified at 2.4V minimum while sourcing 1 mA. This level is compatible with standard TTL thresholds. For a complete discussion on "Interoperation of the DS14C335 with +5V UARTs" please see National Application Note AN-876.

POWER DISSIPATION IN REAL RS-232 APPLICATIONS

The DS14C335 DC-DC Converter uses special circuitry that helps limit the increase in power supply current as frequency increases. A complete description of power dissipation and calculations for RS-232 applications can be found in National Application Note AN-914 titled "Understanding Power Requirements in RS-232 Applications". Typical performance curves are also located in this datasheet for quick reference.

Typical Performance Characteristics

Supply Current vs Frequency vs Driver Loads

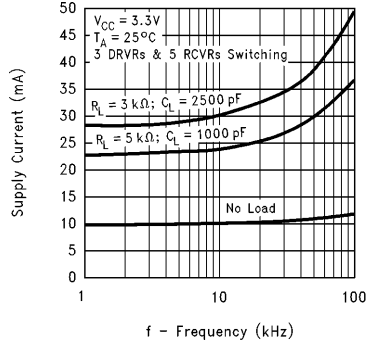

TL/F/11734-12

Supply Current vs Frequency vs Driver Loads

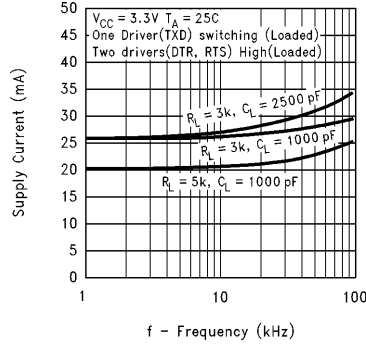

TL/F/11734-13

Supply Power vs Data Rate

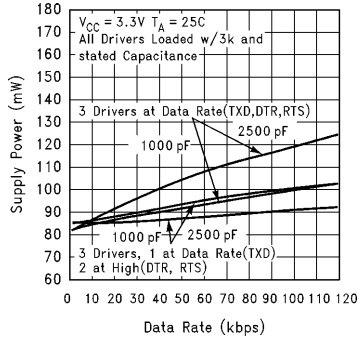

TL/F/11734-14

Supply Current vs Frequency (Receiver)

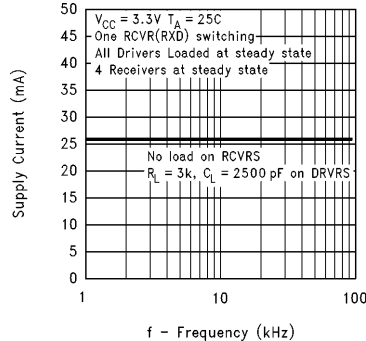

TL/F/11734-15

Driver Output vs Data Rate

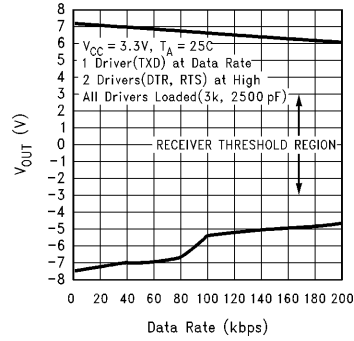

TL/F/11734-16

Physical Dimensions inches (millimeters)

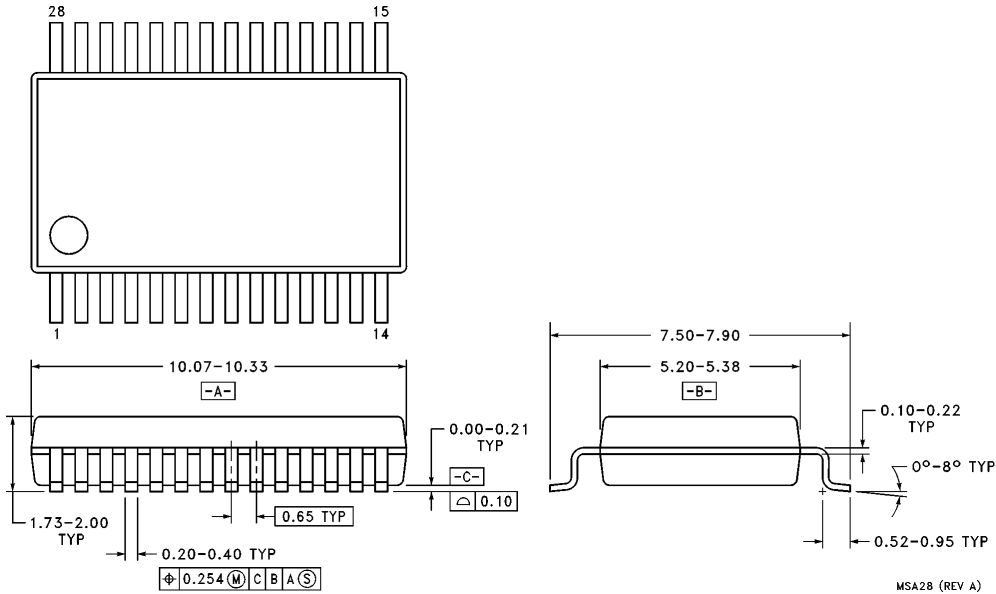

MSA28 (REV A)

**Order Number DS14C335MSA or DS14C335TMSA
NS Package Number MSA28**

LIFE SUPPORT POLICY

NATIONAL'S PRODUCTS ARE NOT AUTHORIZED FOR USE AS CRITICAL COMPONENTS IN LIFE SUPPORT DEVICES OR SYSTEMS WITHOUT THE EXPRESS WRITTEN APPROVAL OF THE PRESIDENT OF NATIONAL SEMICONDUCTOR CORPORATION. As used herein:

1. Life support devices or systems are devices or systems which, (a) are intended for surgical implant into the body, or (b) support or sustain life, and whose failure to perform, when properly used in accordance with instructions for use provided in the labeling, can be reasonably expected to result in a significant injury to the user.
2. A critical component is any component of a life support device or system whose failure to perform can be reasonably expected to cause the failure of the life support device or system, or to affect its safety or effectiveness.



National Semiconductor Corporation
1111 West Bardin Road
Arlington, TX 76017
Tel: 1(800) 272-9959
Fax: 1(800) 737-7018

<http://www.national.com>

National Semiconductor Europe

Fax: +49 (0) 180-530 85 86
Email: europe.support@nsc.com
Deutsch Tel: +49 (0) 180-530 85 85
English Tel: +49 (0) 180-532 78 32
Français Tel: +49 (0) 180-532 93 58
Italiano Tel: +49 (0) 180-534 16 80

National Semiconductor Hong Kong Ltd.

19th Floor, Straight Block,
Ocean Centre, 5 Canton Rd.
Tsimshatsui, Kowloon
Hong Kong
Tel: (852) 2737-1600
Fax: (852) 2736-9960

National Semiconductor Japan Ltd.

Tel: 81-043-299-2308
Fax: 81-043-299-2408