

## DS34F86/DS35F86 RS-422/RS-423 Quad Line Receiver with TRI-STATE® Outputs

### General Description

The DS34F86/DS35F86 RS-422/3 Quad Receiver features four independent receivers, which comply with EIA Standards for the electrical characteristics of balanced/unbalanced voltage digital interface circuits. Receiver outputs are 74LS compatible TRI-STATE structures which are forced to a high impedance state when the appropriate output control lead reaches a logic zero condition. A PNP device buffers each output control lead to assure minimum loading for either logic one or logic zero inputs. In addition each receiver has internal hysteresis circuitry to improve noise margin and discourage output instability for slowly changing input waveforms.

The DS34F86/DS35F86 offers improved performance due to the use of state-of-the-art L-FAST bipolar technology. The L-FAST technology allows for higher speeds and lower currents by utilizing extremely short gate delay times. Thus, the DS34F86/DS35F86 features lower power, extended temperature range, and improved specifications.

The DS34F86/DS35F86 offers optimum performance when used with the DS34F87/DS35F87 Quad Line Driver.

### Features

- Military temperature range
- TRI-STATE outputs
- Fast propagation times (15 ns typical)
- TTL compatible
- 5.0V supply
- Lead compatible and interchangeable with MC3486 and DS3486

### Connection Diagram

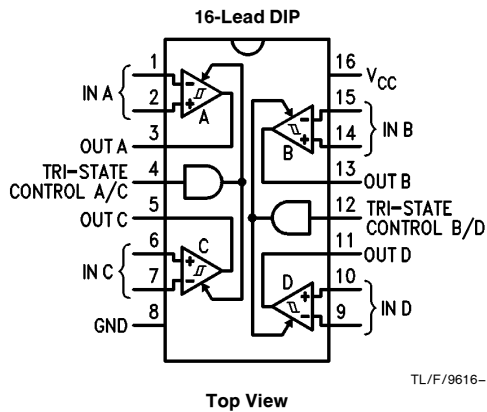

Order Number DS34F86J or DS35F86J  
See NS Package Number J16A

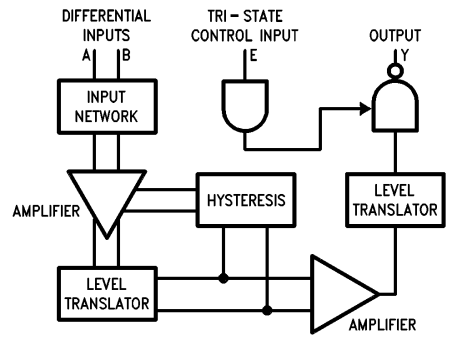

FIGURE 1. Block Diagram

### Function Table (Each Receiver)

Differential Inputs $V_{ID} = (V_{IN+}) - (V_{IN-})$	Enable E	Output OUT
$V_{ID} \geq 0.2V$	H	H
$V_{ID} \leq -0.2V$	H	L
X	L	Z

H = High Level  
L = Low Level  
Z = High Impedance (off)

TRI-STATE® is a registered trademark of National Semiconductor Corporation.

## Absolute Maximum Ratings (Note 1)

If Military/Aerospace specified devices are required, please contact the National Semiconductor Sales Office/Distributors for availability and specifications.

Storage Temperature Range		
Ceramic DIP	–65°C to +175°C	
Operating Temperature Range		
DS35F86	–55°C to +125°C	
DS34F86	0°C to +70°C	
Lead Temperature		
Ceramic DIP (soldering, 60 seconds)	300°C	
Maximum Power Dissipation* at 25°C		
Cavity Package	1500 mW	
Supply Voltage	8.0V	
Input Voltage	8.0V	

Input Common Mode Voltage	±15V
Input Differential Voltage	±25V

\*Derate cavity package 10 mW/°C above 25°C.

## Operating Conditions

DS34F86		
Temperature	0°C to +70°C	
Supply Voltage	4.75V to 5.25V	
DS35F86		
Temperature	–55°C to +125°C	
Supply Voltage	4.5V to 5.5V	
Input Common Mode Voltage Range	–7.0V to +7.0V	
Input Differential Voltage Range	6V	

## Electrical Characteristics over operating range, unless otherwise specified (Notes 2 & 3)

Symbol	Parameter	Conditions	Min	Typ	Max	Units
V <sub>IH</sub>	Input Voltage HIGH		2			V
V <sub>IL</sub>	Input Voltage LOW				0.8	V
V <sub>TH(D)</sub>	Differential Input Threshold Voltage (Note 6)	–7V ≤ V <sub>CM</sub> ≤ 7V, V <sub>IH</sub> = 2V			0.2	V
		V <sub>O</sub> = V <sub>OH</sub> V <sub>O</sub> = V <sub>OL</sub>	–0.2			
I <sub>IB</sub>	Input Bias Current	V <sub>CC</sub> = 0V or 5.25V, Other inputs at 0V			–3.25	mA
					–1.50	
					+1.50	
					+3.25	
V <sub>OH</sub>	Output Voltage HIGH (Note 5)	–7V ≤ V <sub>CM</sub> ≤ 7V V <sub>IH</sub> = 2V, I <sub>O</sub> = –0.4 mA, V <sub>ID</sub> = 0.4V				V
		0°C to +70°C –55°C to +125°C	2.8 2.5			
V <sub>OL</sub>	Output Voltage LOW	–7V ≤ V <sub>CM</sub> ≤ 7V, V <sub>IH</sub> = 2V			0.5	V
I <sub>OZ</sub>	Off State (High Impedance) Output Current	V <sub>I(D)</sub> = +3V, V <sub>IL</sub> = 0.8V, V <sub>O</sub> = 0.5V			–10	μA
		V <sub>I(D)</sub> = –3V, V <sub>IL</sub> = 0.8V, V <sub>O</sub> = 2.7V			10	
I <sub>OS</sub>	Output Short Circuit Current (Note 4)	V <sub>I(D)</sub> = +3V, V <sub>IH</sub> = 2V, V <sub>O</sub> = 0V	–15		–100	mA
I <sub>IL</sub>	Input Current LOW (TRI-STATE Control)	V <sub>IL</sub> = 0.5V			–100	μA
I <sub>IH</sub>	Input Current HIGH (TRI-STATE Control)				20	μA
		V <sub>IH</sub> = 2.7V V <sub>IH</sub> = 5.25V			40	
V <sub>IC</sub>	Input Clamp Diode Voltage (TRI-STATE Control)	I <sub>IC</sub> = –10 mA			–1.5	V
I <sub>CC</sub>	Supply Current	V <sub>IL</sub> = 0V			50	mA

**Note 1:** "Absolute Maximum Ratings" are those values beyond which the safety of the device cannot be guaranteed. They are not meant to imply that the devices should be operated at these limits. The tables of "Electrical Characteristics" provide conditions for actual device operation.

**Note 2:** Unless otherwise specified min/max limits apply across the  $-55^{\circ}\text{C}$  to  $+125^{\circ}\text{C}$  temperature range for the DS35F86 and across the  $0^{\circ}\text{C}$  to  $+70^{\circ}\text{C}$  range for the DS34F86. All typicals are given for  $V_{CC} = 5\text{V}$  and  $T_A = 25^{\circ}\text{C}$ .

**Note 3:** All currents into the device pins are positive; all currents out of the device pins are negative. All voltages are reference to ground unless otherwise specified.

**Note 4:** Only one output at a time should be shorted.

**Note 5:** Refer to EIA RS-422/3 for exact conditions. Input balance and  $V_{OH}/V_{OL}$  levels are tested simultaneously for worst case.

**Note 6:** Differential input threshold voltage and guaranteed output levels are tested simultaneously for worst case.

### Switching Characteristics $V_{CC} = 5\text{V}$ , $T_A = 25^{\circ}\text{C}$ (Figures 2 & 3)

Symbol	Parameter	Conditions	Min	Typ (Note 1)	Max	Units
$t_{PHL(D)}$	Propagation Delay Time Differential Inputs to Outputs	Figure 2		15	22	ns
$t_{PLH(D)}$				15	22	ns
$t_{LZ}$	Propagation Delay Time Controls to Outputs	$C_L = 5\text{ pF}$ Figure 3		14	18	ns
$t_{HZ}$				15	20	ns
$t_{ZH}$		Figure 3		12	16	ns
$t_{ZL}$				13	18	ns

### Parameter Measurement Information

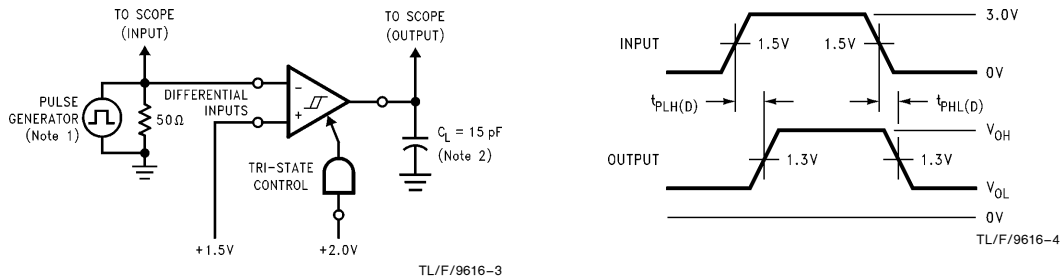

**FIGURE 2. Propagation Delay Differential Input to Output**

## Parameter Measurement Information (Continued)

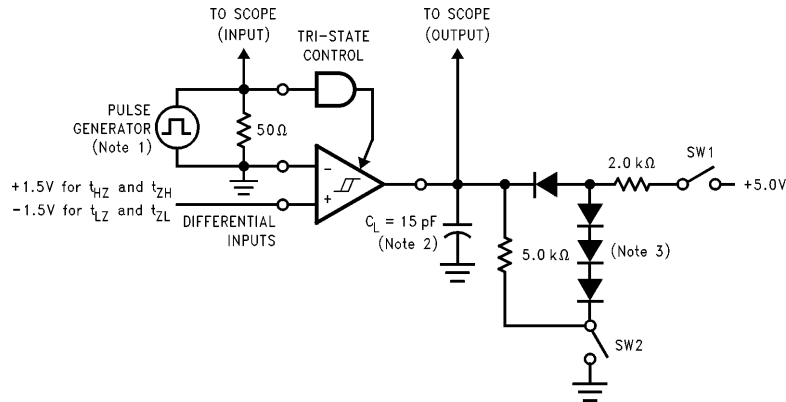

TL/F/9616-5

FIGURE 3. Propagation Delay TRI-STATE Control Input to Output

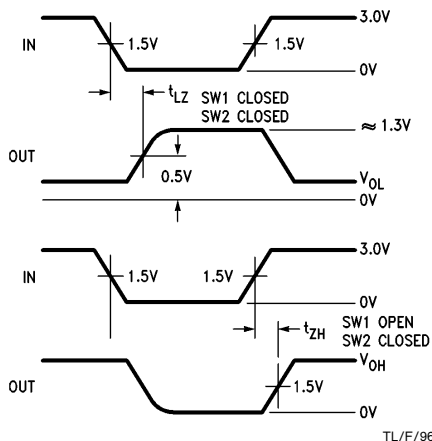

FIGURE 3a.  $t_{LZ}$ ,  $t_{ZH}$

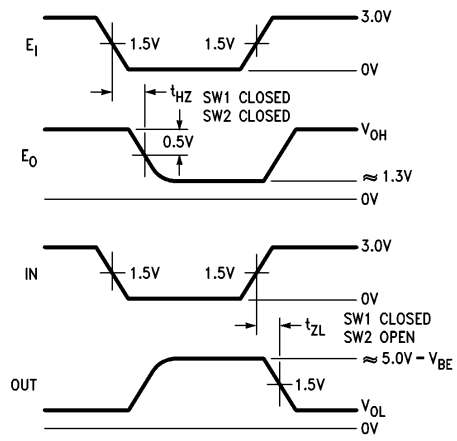
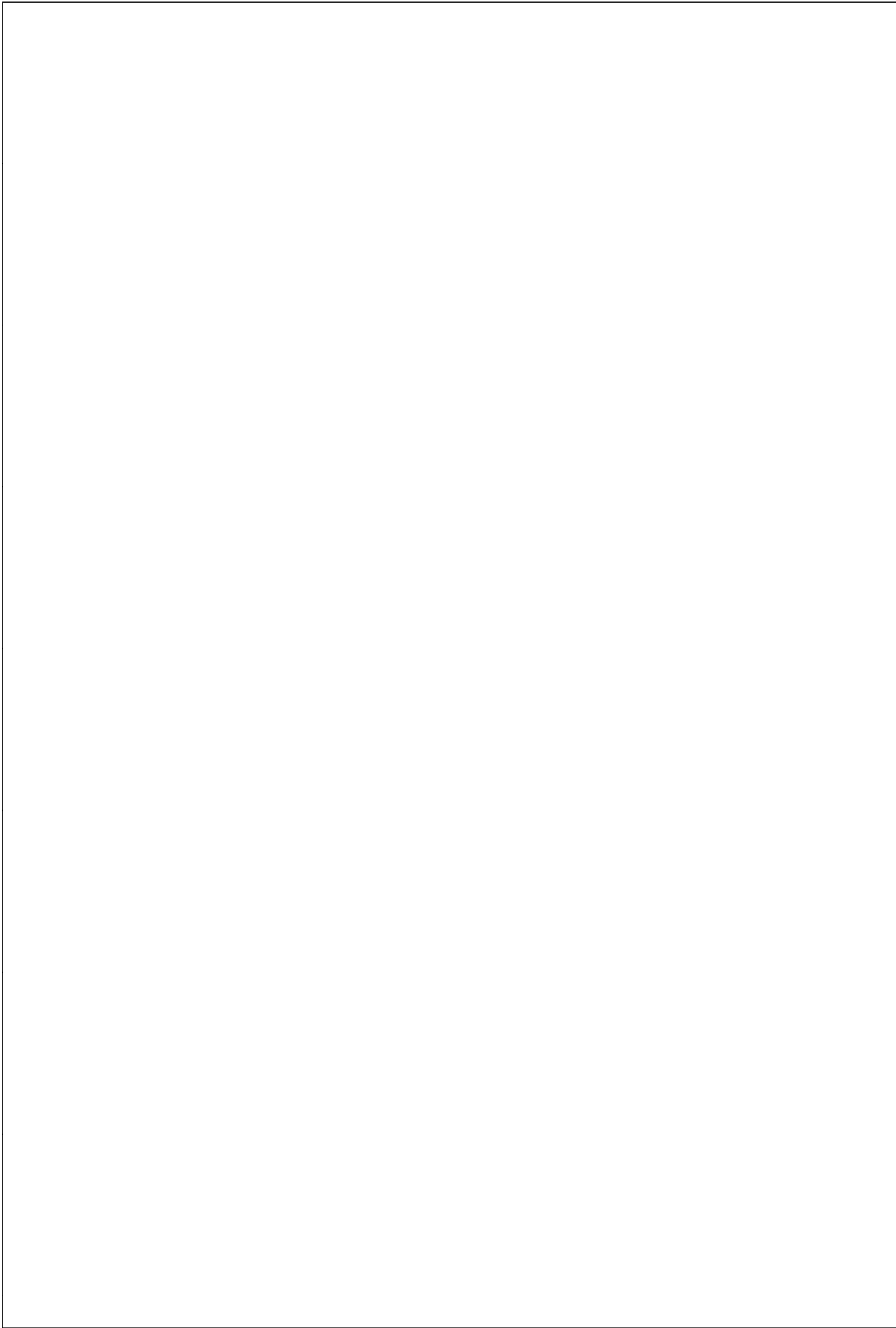

FIGURE 3b.  $t_{HZ}$ ,  $t_{ZL}$

**Note 1:** The input pulse is supplied by a generator having the following characteristics: PRR = 1.0 MHz, 50% duty cycle,  $t_{TLH} = t_{THL} = 6.0$  ns (10% to 90%),  $Z_O = 50\Omega$ .

**Note 2:**  $C_L$  includes probe and jig capacitance.

**Note 3:** All diodes are IN916 or equivalent.



**Physical Dimensions** inches (millimeters)

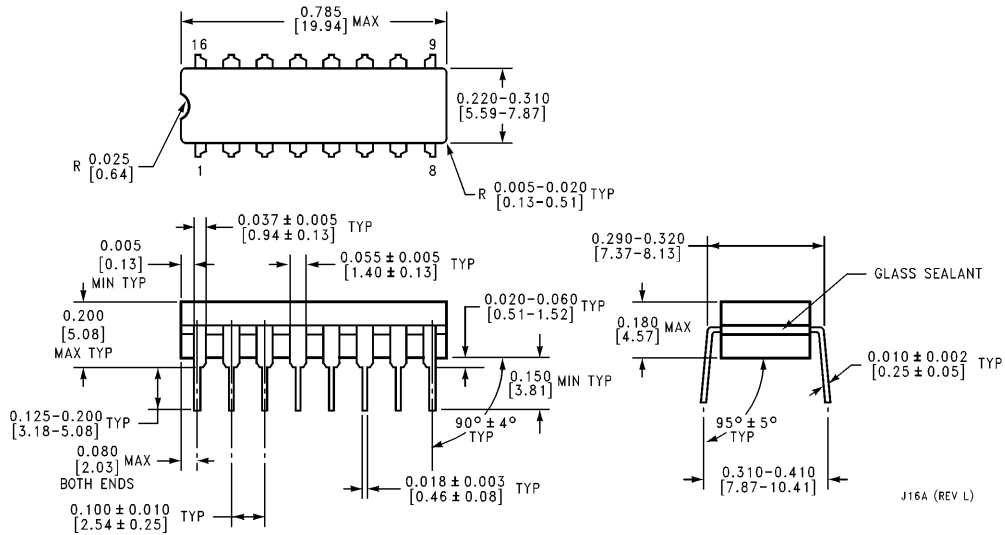

**Ceramic Dual-In-Line Package (J)**  
**Order Number DS34F86J or DS35F86J**  
**NS Package Number J16A**

**LIFE SUPPORT POLICY**

NATIONAL'S PRODUCTS ARE NOT AUTHORIZED FOR USE AS CRITICAL COMPONENTS IN LIFE SUPPORT DEVICES OR SYSTEMS WITHOUT THE EXPRESS WRITTEN APPROVAL OF THE PRESIDENT OF NATIONAL SEMICONDUCTOR CORPORATION. As used herein:

1. Life support devices or systems are devices or systems which, (a) are intended for surgical implant into the body, or (b) support or sustain life, and whose failure to perform, when properly used in accordance with instructions for use provided in the labeling, can be reasonably expected to result in a significant injury to the user.
2. A critical component is any component of a life support device or system whose failure to perform can be reasonably expected to cause the failure of the life support device or system, or to affect its safety or effectiveness.



**National Semiconductor Corporation**  
 1111 West Bardin Road  
 Arlington, TX 76017  
 Tel: (800) 272-9959  
 Fax: (800) 737-7018

<http://www.national.com>

**National Semiconductor Europe**

Fax: +49 (0) 180-530 85 86  
 Email: [europe.support@nsc.com](mailto:europe.support@nsc.com)  
 Deutsch Tel: +49 (0) 180-530 85 85  
 English Tel: +49 (0) 180-532 78 32  
 Français Tel: +49 (0) 180-532 93 58  
 Italiano Tel: +49 (0) 180-534 16 80

**National Semiconductor Hong Kong Ltd.**

19th Floor, Straight Block,  
 Ocean Centre, 5 Canton Rd.  
 Tsimshatsui, Kowloon  
 Hong Kong  
 Tel: (852) 2737-1600  
 Fax: (852) 2736-9960

**National Semiconductor Japan Ltd.**

Tel: 81-043-299-2308  
 Fax: 81-043-299-2408

National does not assume any responsibility for use of any circuitry described, no circuit patent licenses are implied and National reserves the right at any time without notice to change said circuitry and specifications.