

DS36954 Quad Differential Bus Transceiver

General Description

The DS36954 is a low power, quad EIA-485 differential bus transceiver especially suited for high speed, parallel, multipoint, I/O bus applications. A compact 20-pin surface mount PLCC or SOIC package provides high transceiver integration and a very small PC board footprint.

Propagation delay skew between devices is specified to aid in parallel interface designs—limits on maximum and minimum delay times are guaranteed.

Five devices can implement a complete SCSI initiator or target interface. Three transceivers in a package are pinned out for data bus connections. The fourth transceiver, with the flexibility provided by its individual enables, can serve as a control bus transceiver.

Features

- Pinout for SCSI interface
- Compact 20-pin PLCC or SOIC package
- Meets EIA-485 standard for multipoint bus transmission
- Greater than 60 mA source/sink currents
- Thermal shutdown protection
- Glitch-free driver outputs on power up and down

Connection Diagrams

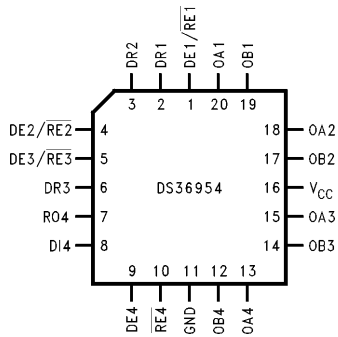

TL/F/11014-1

Order Number DS36954V
See NS Package Number V20A

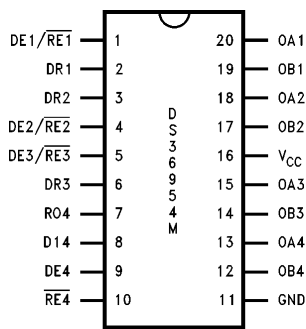

TL/F/11014-19

Order Number DS36954M
See NS Package Number M20B

Logic Diagrams

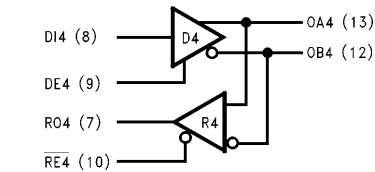
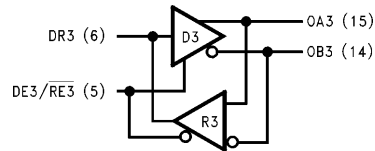
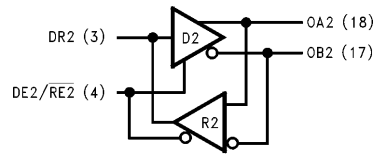
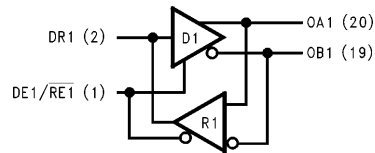

TL/F/11014-2

TRI-STATE® is a registered trademark of National Semiconductor Corporation.

Absolute Maximum Ratings (Note 1)

If Military/Aerospace specified devices are required, please contact the National Semiconductor Sales Office/Distributors for availability and specifications.

Supply Voltage	7V
Control Input Voltage	$V_{CC} + 0.5V$
Driver Input Voltage	$V_{CC} + 0.5V$
Driver Output Voltage/ Receiver Input Voltage	-10V to +15V
Receiver Output Voltage	5.5V
Continuous Power Dissipation @ +25°C	
V Package	1.73W
M Package	1.73W
Derate V Package	13.9 mW/°C above +25°C
Derate M Package	13.7 mW/°C above +25°C

Storage Temperature Range	-65°C to +150°C
Lead Temperature (Soldering 4 Sec.)	260°C

Recommended Operating Conditions

	Min	Max	Units
Supply Voltage, V_{CC}	4.75	5.25	V
Bus Voltage	-7	+12	V
Operating Free Air Temperature (T_A)	0	+70	°C

Electrical Characteristics

Over Supply Voltage and Operating Temperature ranges, unless otherwise specified (Note 2)

Symbol	Parameter	Conditions	Min	Typ	Max	Units
DRIVER CHARACTERISTICS						
V_{ODL}	Differential Driver Output Voltage (Full Load)	$I_L = 60\text{ mA}$ $V_{CM} = 0V$	1.5	1.9		V
V_{OD}	Differential Driver Output Voltage (Termination Load)	$R_L = 100\Omega$ (EIA-422)	2.0	2.25		V
		$R_L = 54\Omega$ (EIA-485)	1.5	2.0		V
ΔV_{ODI}	Change in Magnitude of Driver Differential Output Voltage for Complementary Output States	$R_L = 54$ or 100Ω (Note 4) (Figure 1) (EIA-422/485)			0.2	V
V_{OC}	Driver Common Mode Output Voltage (Note 5)	$R_L = 54\Omega$ (Figure 1) (EIA-485)			3.0	V
ΔV_{OCI}	Change in Magnitude of Common Mode Output Voltage	(Note 4) (Figure 1) (EIA-422/485)			0.2	V
V_{OH}	Output Voltage High	$I_{OH} = -55\text{ mA}$	2.7	3.2		V
V_{OL}	Output Voltage Low	$I_{OL} = 55\text{ mA}$		1.4	1.7	V
V_{IH}	Input Voltage High		2.0			V
V_{IL}	Input Voltage Low				0.8	V
V_{CL}	Input Clamp Voltage	$I_{CL} = -18\text{ mA}$			-1.5	V
I_{IH}	Input High Current	$V_{IN} = 2.4V$ (Note 3)			20	μA
I_{IL}	Input Low Current	$V_{IN} = 0.4V$ (Note 3)			-20	μA
I_{OSC}	Driver Short-Circuit Output Current (Note 9)	$V_O = -7V$ (EIA-485)		-130	-250	mA
		$V_O = 0V$ (EIA-422)		-90	-150	mA
		$V_O = +12V$ (EIA-485)		130	250	mA

Electrical Characteristics

Over Supply Voltage and Operating Temperature ranges, unless otherwise specified (Note 2) (Continued)

Symbol	Parameter	Conditions	Min	Typ	Max	Units
RECEIVER CHARACTERISTICS						
I_{OSR}	Short Circuit Output Current	$V_O = 0V$ (Note 9)	-15	-28	-75	mA
I_{OZ}	TRI-STATE® Output Current	$V_O = 0.4V$ to $2.4V$			20	μA
V_{OH}	Output Voltage High	$V_{ID} = 0.2V$, $I_{OH} = 0.4$ mA	2.4	3.0		V
V_{OL}	Output Voltage Low	$V_{ID} = -0.2V$, $I_{OL} = 4$ mA		0.35	0.5	V
V_{TH}	Differential Input High Threshold Voltage	$V_O = V_{OH}$, $I_O = -0.4$ mA (EIA-422/485)		0.03	0.2	V
V_{TL}	Differential Input Low Threshold Voltage (Note 6)	$V_O = V_{OL}$, $I_O = 4.0$ mA (EIA-422/485)	-0.20	-0.03		V
V_{HST}	Hysteresis (Note 7)	$V_{CM} = 0V$	35	60		mV
DRIVER AND RECEIVER CHARACTERISTICS						
V_{IH}	Enable Input Voltage High		2.0			V
V_{IL}	Enable Input Voltage Low				0.8	V
V_{CL}	Enable Input Clamp Voltage	$I_{CL} = -18$ mA			-1.5	V
I_{IN}	Line Input Current (Note 8)	Other Input = 0V $DE/\overline{RE} = 0.8V$ $DE4 = 0.8V$	$V_I = +12V$	0.5	1.0	mA
			$V_I = -7V$	-0.45	-0.8	mA
I_{ING}	Line Input Current (Note 8)	Other Input = 0V DE/\overline{RE} and $DE4 = 2V$ $V_{CC} = 3.0V$ $T_A = +25^\circ C$	$V_I = +12V$		1.0	mA
			$V_I = -7V$		-0.8	mA
I_{IH}	Enable Input Current High	$V_{IN} = 2.4V$ DE/\overline{RE}	$V_{CC} = 3.0V$	1	40	μA
			$V_{CC} = 4.75V$	1		μA
			$V_{CC} = 5.25V$	1	40	μA
		$V_{IN} = 2.4V$ $DE4$ or $\overline{RE4}$	$V_{CC} = 3.0V$	1	20	μA
$V_{CC} = 5.25V$	1		20	μA		
I_{IL}	Enable Input Current Low	$V_{IN} = 0.8V$ DE/\overline{RE}	$V_{CC} = 3.0V$	-6	-40	μA
			$V_{CC} = 4.75V$	-12		μA
			$V_{CC} = 5.25V$	-14	-40	μA
		$V_{IN} = 0.8V$ $DE4$ or $\overline{RE4}$	$V_{CC} = 3.0V$	-3	-20	μA
$V_{CC} = 5.25V$	-7		-20	μA		
I_{CCD}	Supply Current (Note 10)	No Load, DE/\overline{RE} and $DE4 = 2.0V$		75	90	mA
I_{CCR}	Supply Current (Note 10)	No Load, DE/\overline{RE} and $\overline{RE4} = 0.8V$		50	70	mA

Switching Characteristics

Over Supply Voltage and Operating Temperature ranges, unless otherwise specified.

Symbol	Parameter	Conditions	Min	Typ	Max	Units
DRIVER SINGLE-ENDED CHARACTERISTICS						
t _{PZH}	Output Enable Time to High Level	R _L = 110Ω	(Figure 5)	35	40	ns
t _{PZL}	Output Enable Time to Low Level		(Figure 6)	25	40	ns
t _{PHZ}	Output Disable Time to High Level		(Figure 5)	15	25	ns
t _{PLZ}	Output Disable Time to Low Level		(Figure 6)	35	40	ns
DRIVER DIFFERENTIAL CHARACTERISTICS						
t _r , t _f	Rise and Fall Time	R _L = 54Ω C _L = 50 pF C _D = 15 pF (Figures 3, 4, and 9)		13	16	ns
t _{PLHD}	Differential Propagation Delays (Note 15)		9	15	19	ns
t _{PHLD}			9	12	19	ns
t _{SKD}	t _{PLHD} - t _{PHLD} Diff. Skew			3	6	ns
RECEIVER CHARACTERISTICS						
t _{PLHD}	Differential Propagation Delays	C _L = 15 pF V _{CM} = 2.0V (Figure 7)	9	14	19	ns
t _{PHLD}			9	13	19	ns
t _{SKD}	t _{PLHD} - t _{PHLD} Diff. Receiver Skew			1	3	ns
t _{PZH}	Output Enable Time to High Level	C _L = 15 pF (Figure 8)		15	22	ns
t _{PZL}	Output Enable Time to Low Level			20	30	ns
t _{PHZ}	Output Disable Time from High Level			20	30	ns
t _{PLZ}	Output Disable Time from Low Level			17	25	ns

Note 1: "Absolute Maximum Ratings" are those values beyond which the safety of the device cannot be guaranteed. They are not meant to imply that the devices should be operated at these limits. The tables of "Electrical Characteristics" specify conditions for device operation.

Note 2: Current into device pins is defined as positive. Current out of device pins is defined as negative. All voltages are referenced to ground unless otherwise specified.

Note 3: I_{IH} and I_{IL} include driver input current and receiver TRI-STATE leakage current on DR(1-3).

Note 4: Δ IVODI and Δ IVOCI are changes in magnitude of V_{OD} and V_{OC}, respectively, that occur when the input changes state.

Note 5: In EIA Standards EIA-422 and EIA-485, V_{OC}, which is the average of the two output voltages with respect to ground, is called output offset voltage, V_{OS}.

Note 6: Threshold parameter limits specified as an algebraic value rather than by magnitude.

Note 7: Hysteresis defined as V_{HST} = V_{TH} - V_{TL}.

Note 8: I_{IN} includes the receiver input current and driver TRI-STATE leakage current.

Note 9: Short one output at a time.

Note 10: Total package supply current.

Note 11: All typicals are given for V_{CC} = 5.0V and T_A = +25°C.

Parameter Measurement Information

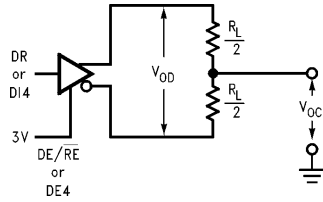

TL/F/11014-3

FIGURE 1. Driver V_{OD} and V_{OC} (Note 13)

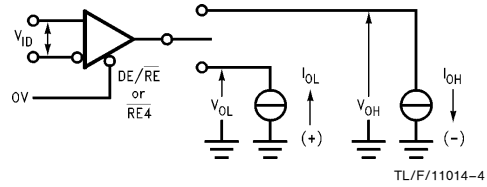

TL/F/11014-4

FIGURE 2. Receiver V_{OH} and V_{OL}

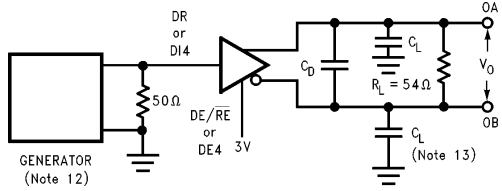

TL/F/11014-5

FIGURE 3. Driver Differential Propagation Delay Load Circuit

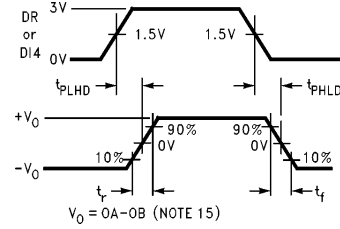

TL/F/11014-6

FIGURE 4. Driver Differential Propagation Delays and Transition Times

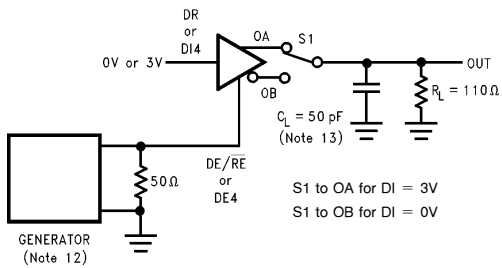

TL/F/11014-7

FIGURE 5. Driver Enable and Disable Timing (t_{pZH} , t_{pHZ})

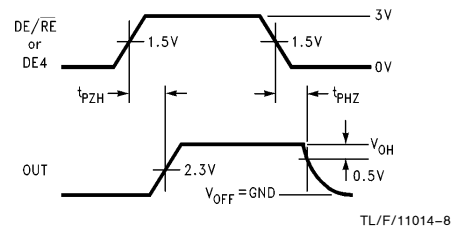

TL/F/11014-8

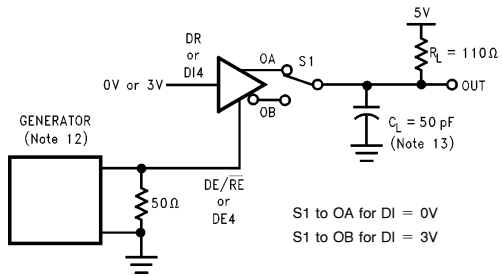

TL/F/11014-9

FIGURE 6. Driver Enable and Disable Timing (t_{pZL} , t_{pLZ})

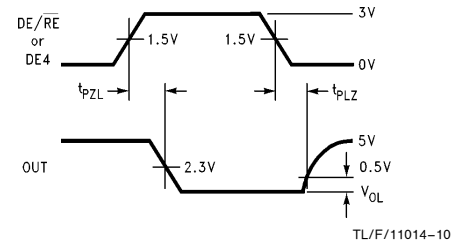

TL/F/11014-10

Parameter Measurement Information (Continued)

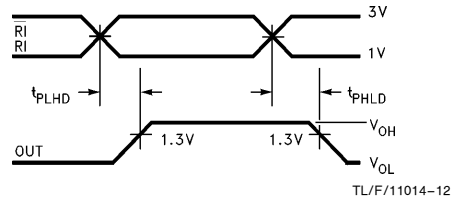
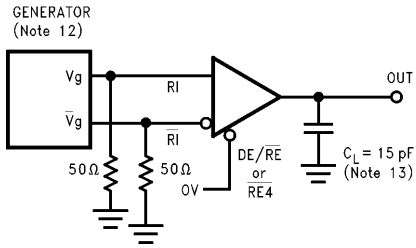

TL/F/11014-11

FIGURE 7. Receiver Differential Propagation Delay Timing

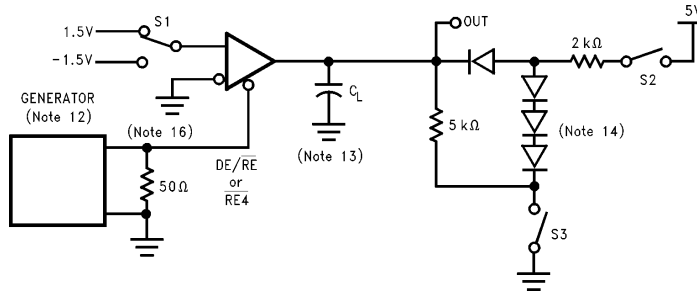

TL/F/11014-13

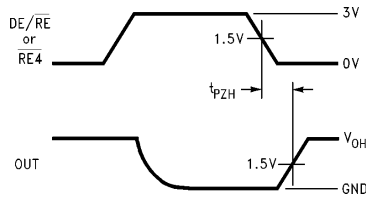

$S1\ 1.5V$
 $S2\ \text{Open}$
 $S3\ \text{Closed}$

TL/F/11014-14

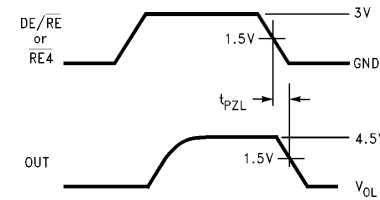

$S1\ -1.5V$
 $S2\ \text{Closed}$
 $C3\ \text{Open}$

TL/F/11014-15

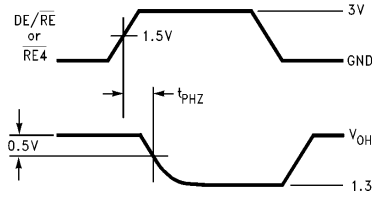

$S1\ 1.5V$
 $S2\ \text{Closed}$
 $C3\ \text{Closed}$

TL/F/11014-16

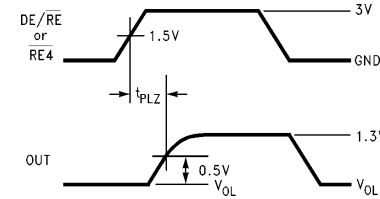

$S1\ -1.5V$
 $S2\ \text{Closed}$
 $C3\ \text{Closed}$

TL/F/11014-17

FIGURE 8. Receiver Enable and Disable Timing

Parameter Measurement Information (Continued)

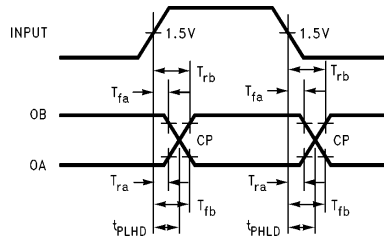

TL/F/11014-18

$$T_{CP} = \frac{(T_{fb} \times T_{rb}) - (T_{ra} \times T_{fa})}{T_{rb} - T_{ra} - T_{fa} + T_{fb}}$$

T_{ra} , T_{rb} , T_{fa} and T_{fb} are propagation delay measurements to the 20% and 80% levels.

T_{CP} = Crossing Point

FIGURE 9. Propagation Delay Timing for Calculations of Driver Differential Propagation Delays

Note 12: The input pulse is supplied by a generator having the following characteristics: $f = 1.0$ MHz, 50% duty cycle, t_r and $t_f < 6.0$ ns, $Z_O = 50\Omega$.

Note 13: C_L includes probe and stray capacitance.

Note 14: Diodes are 1N916 or equivalent.

Note 15: Differential propagation delays are calculated from single-ended propagation delays measured from driver input to the 20% and 80% levels on the driver outputs (Figure 9).

Note 16: On transceivers 1-3 the driver is loaded with receiver input conditions when DE/\overline{RE} is high. Do not exceed the package power dissipation limit when testing.

Physical Dimensions inches (millimeters)

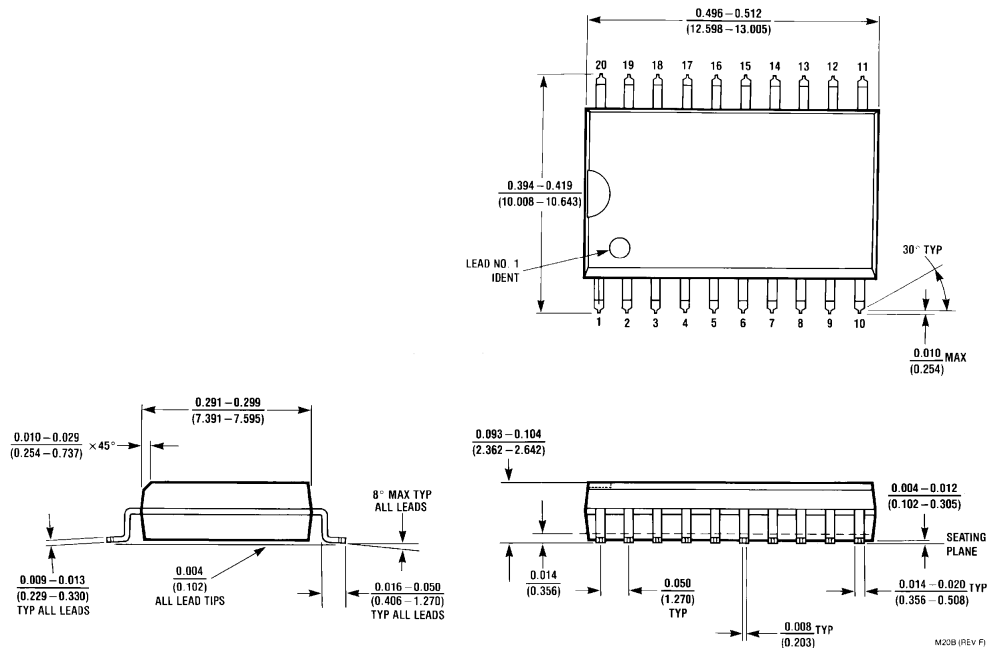

Order Number DS36954M
NS Package Number M20B

Physical Dimensions inches (millimeters) (Continued)

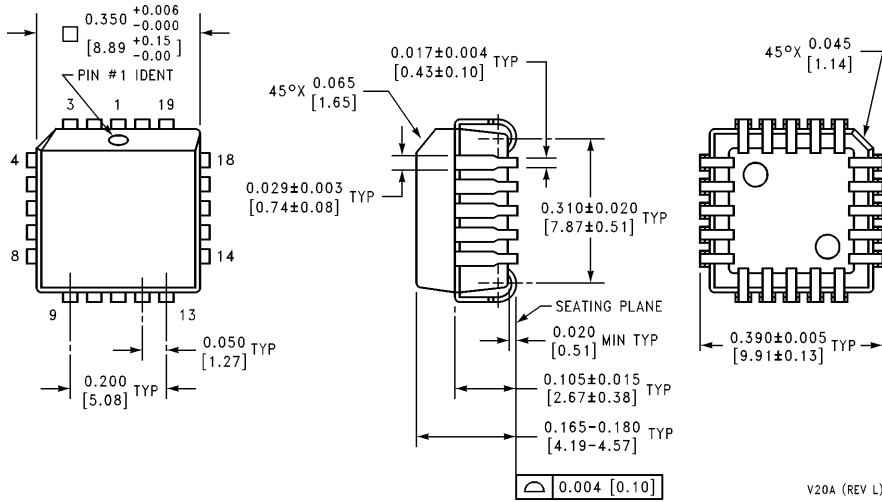

Order Number DS36954V
NS Package Number V20A

LIFE SUPPORT POLICY

NATIONAL'S PRODUCTS ARE NOT AUTHORIZED FOR USE AS CRITICAL COMPONENTS IN LIFE SUPPORT DEVICES OR SYSTEMS WITHOUT THE EXPRESS WRITTEN APPROVAL OF THE PRESIDENT OF NATIONAL SEMICONDUCTOR CORPORATION. As used herein:

1. Life support devices or systems are devices or systems which, (a) are intended for surgical implant into the body, or (b) support or sustain life, and whose failure to perform, when properly used in accordance with instructions for use provided in the labeling, can be reasonably expected to result in a significant injury to the user.
2. A critical component is any component of a life support device or system whose failure to perform can be reasonably expected to cause the failure of the life support device or system, or to affect its safety or effectiveness.



National Semiconductor Corporation
 1111 West Bardin Road
 Arlington, TX 76017
 Tel: 1(800) 272-9959
 Fax: 1(800) 737-7018

<http://www.national.com>

National Semiconductor Europe

Fax: +49 (0) 180-530 85 86
 Email: europe.support@nsc.com
 Deutsch Tel: +49 (0) 180-530 85 85
 English Tel: +49 (0) 180-532 78 32
 Français Tel: +49 (0) 180-532 93 58
 Italiano Tel: +49 (0) 180-534 16 80

National Semiconductor Hong Kong Ltd.

19th Floor, Straight Block,
 Ocean Centre, 5 Canton Rd.
 Tsimshatsui, Kowloon
 Hong Kong
 Tel: (852) 2737-1600
 Fax: (852) 2736-9960

National Semiconductor Japan Ltd.

Tel: 81-043-299-2308
 Fax: 81-043-299-2408