

## DS75123 Dual Line Driver

### General Description

The DS75123 is a monolithic dual line driver designed specifically to meet the I/O interface specifications for IBM System 360. It is compatible with standard TTL logic and supply voltage levels.

The low-impedance emitter-follower outputs of the DS75123 enable driving terminated low impedance lines. In addition the outputs are uncommitted allowing two or more drivers to drive the same line.

Output short-circuit protection is incorporated to turn off the output when the output voltage drops below approximately 1.5V.

### Features

- Meet IBM System 360 I/O interface specifications for digital data transmission over 50Ω to 500Ω coaxial cable, strip line, or terminated pair transmission lines
- TTL compatible with single 5.0V supply
- 3.11V output at  $I_{OH} = -59.3 \text{ mA}$
- Open emitter-follower output structure for party-line operation
- Short circuit protection
- AND-OR logic configuration
- Plug-in replacement for the SN75123 and the 8T23

### Connection Diagram

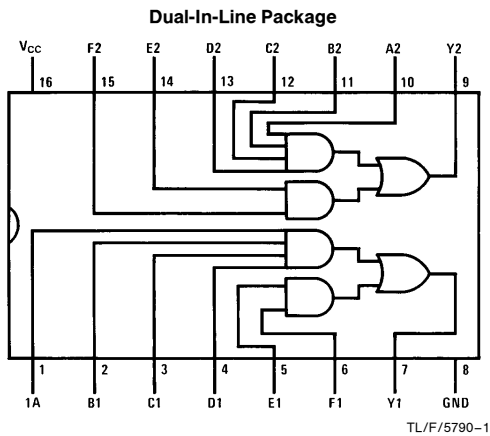

### Typical Performance Characteristics

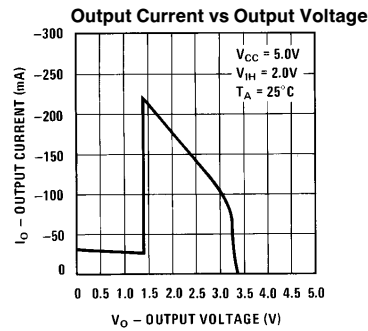

### Truth Table

INPUTS						OUTPUT
A	B	C	D	E	F	Y
H	H	H	H	X	X	H
X	X	X	X	H	H	H
All Other Input Combinations						L

H = High level, L = Low level, X = Irrelevant

### AC Test Circuit and Switching Time Waveforms

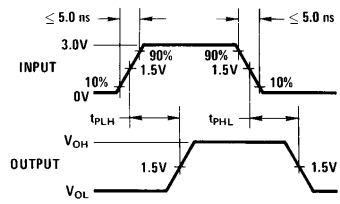
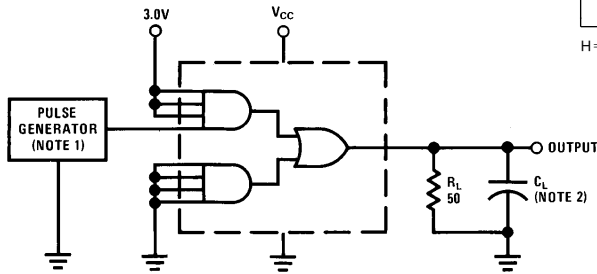

**Note 1:** The pulse generators have the following characteristics:  $Z_{OUT} \approx 50\Omega$ ,  $t_W = 200 \text{ ns}$ , duty cycle = 50%.

**Note 2:**  $C_L$  includes probe and jig capacitance.

## Absolute Maximum Ratings (Note 1)

If Military/Aerospace specified devices are required, please contact the National Semiconductor Sales Office/Distributors for availability and specifications.

Supply Voltage, $V_{CC}$	7.0V
Input Voltage	5.5V
Output Voltage	7.0V
Maximum Power Dissipation* at 25°C	
Molded Package	1280 mW
Operating Free-Air Temperature Range	0°C to +75°C
Storage Temperature Range	-65°C to +150°C
Lead Temperature (Soldering, 4 seconds)	260°C

\*Derate molded package 10.2 mW/°C above 25°C.

## Operating Conditions

	Min	Max	Units
Supply Voltage, $V_{CC}$	4.75	5.25	V
High Level Output Current, $I_{OH}$		-100	mA
Temperature, $T_A$	0	+75	°C

## Electrical Characteristics (Notes 2 and 3)

Symbol	Parameter	Conditions	Min	Typ	Max	Units
$V_{IH}$	High Level Input Voltage		2.0			V
$V_{IL}$	Low Level Input Voltage				0.8	V
$V_I$	Input Clamp Voltage	$V_{CC} = 5.0V, I_I = -12\text{ mA}$			-1.5	V
$I_I$	Input Current at Max Input Voltage	$V_{CC} = 5.25V, V_{IN} = 5.5V$			1	mA
$V_{OH}$	High Level Output Voltage	$V_{CC} = 5.0V, V_{IH} = 2.0V, I_{OH} = -59.3\text{ mA}, (\text{Note } 4)$	$T_A = 25^\circ\text{C}$	3.11		V
			$T_A = 0^\circ\text{C to } +75^\circ\text{C}$	2.9		V
$I_{OH}$	High Level Output Current	$V_{CC} = 5.0V, V_{IH} = 4.5V, T_A = 25^\circ\text{C}, V_{OH} = 2.0V, (\text{Note } 4)$	-100		-250	mA
$V_{OL}$	Low Level Output Voltage	$V_{IL} = 0.8V, I_{OL} = -240\ \mu\text{A}, (\text{Note } 4)$			0.15	V
$I_{O(OFF)}$	Off State Output Current	$V_{CC} = 0, V_O = 3.0V$			40	$\mu\text{A}$
$I_{IH}$	High Level Input Current	$V_I = 4.5V$			40	$\mu\text{A}$
$I_{IL}$	Low Level Input Current	$V_I = 0.4V$	-0.1		-1.6	mA
$I_{OS}$	Short Circuit Output Current	$V_{CC} = 5.0V, T_A = 25^\circ\text{C}$			-30	mA
$I_{CCH}$	Supply Current, Outputs High	$V_{CC} = 5.25V, \text{All Inputs at } 2.0V, \text{Outputs Open}$			28	mA
$I_{CCL}$	Supply Current, Outputs Low	$V_{CC} = 5.25V, \text{All Inputs at } 0.8V, \text{Outputs Open}$			60	mA

## Switching Characteristics $V_{CC} = 5.0V, T_A = 25^\circ\text{C}$

Symbol	Parameter	Conditions	Min	Typ	Max	Units	
$t_{PLH}$	Propagation Delay Time, Low-to-High Level Output	$R_L = 50\ \Omega, (\text{See AC Test Circuit and Switching Time Waveforms})$	$C_L = 15\ \text{pF}$		12	20	ns
			$C_L = 100\ \text{pF}$		20	35	ns
$t_{PHL}$	Propagation Delay Time, High-to-Low Level Output	$R_L = 50\ \Omega, (\text{See AC Test Circuit and Switching Time Waveforms})$	$C_L = 15\ \text{pF}$		12	20	ns
			$C_L = 100\ \text{pF}$		15	25	ns

**Note 1:** "Absolute Maximum Ratings" are those values beyond which the safety of the device cannot be guaranteed. Except for "Operating Temperature Range" they are not meant to imply that the devices should be operated at these limits. The table of "Electrical Characteristics" provides conditions for actual device operation.

**Note 2:** All currents into device pins are shown as positive, currents out of device pins shown as negative, all voltage values are referenced with respect to network ground terminal, unless otherwise noted. All values shown as max or min on absolute value basis.

**Note 3:** Min/max limits apply across the guaranteed operating temperature range of 0°C to +75°C for DS75123, unless otherwise specified. Typical values are for  $V_{CC} = 5.0V, T_A = 25^\circ\text{C}$ . Positive current is defined as current into the referenced pin.

**Note 4:** The output voltage and current limits are guaranteed for any appropriate combination of high and low inputs specified by the truth table for the desired output.



**Physical Dimensions** inches (millimeters)

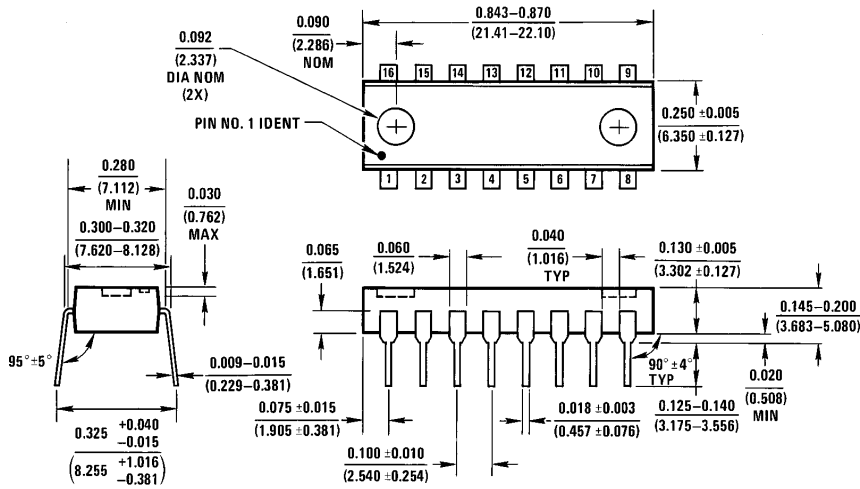

**Molded Dual-In-Line Package (N)**  
**Order Number DS75123N**  
**NS Package Number N16A**

N16A (REV E)

**LIFE SUPPORT POLICY**

NATIONAL'S PRODUCTS ARE NOT AUTHORIZED FOR USE AS CRITICAL COMPONENTS IN LIFE SUPPORT DEVICES OR SYSTEMS WITHOUT THE EXPRESS WRITTEN APPROVAL OF THE PRESIDENT OF NATIONAL SEMICONDUCTOR CORPORATION. As used herein:

1. Life support devices or systems are devices or systems which, (a) are intended for surgical implant into the body, or (b) support or sustain life, and whose failure to perform, when properly used in accordance with instructions for use provided in the labeling, can be reasonably expected to result in a significant injury to the user.
2. A critical component is any component of a life support device or system whose failure to perform can be reasonably expected to cause the failure of the life support device or system, or to affect its safety or effectiveness.



**National Semiconductor Corporation**  
 1111 West Bardin Road  
 Arlington, TX 76017  
 Tel: 1(800) 272-9959  
 Fax: 1(800) 737-7018

<http://www.national.com>

**National Semiconductor Europe**

Fax: +49 (0) 180-530 85 86  
 Email: [europe.support@nsc.com](mailto:europe.support@nsc.com)  
 Deutsch Tel: +49 (0) 180-530 85 85  
 English Tel: +49 (0) 180-532 78 32  
 Français Tel: +49 (0) 180-532 93 58  
 Italiano Tel: +49 (0) 180-534 16 80

**National Semiconductor Hong Kong Ltd.**

19th Floor, Straight Block,  
 Ocean Centre, 5 Canton Rd.  
 Tsimshatsui, Kowloon  
 Hong Kong  
 Tel: (852) 2737-1600  
 Fax: (852) 2736-9960

**National Semiconductor Japan Ltd.**

Tel: 81-043-299-2308  
 Fax: 81-043-299-2408