



F100163

Dual 8-Input Multiplexer

General Description

The F100163 is a dual 8-input multiplexer. The Data Select (S_n) inputs determine which bit (A_n and B_n) will be presented at the outputs (Z_a and Z_b respectively). The same bit (0-7) will be selected for both the Z_a and Z_b output. All inputs have 50 k Ω pulldown resistors.

Refer to the F100363 datasheet for:

- PCC packaging
- Lower power
- Military versions
- Extended voltage specs (-4.2V to -5.7V)

Ordering Code: See Section 8

Logic Symbol

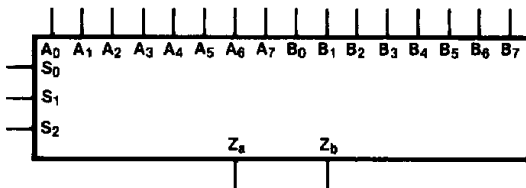

TL/F/9864-3

Pin Names	Description
S_0 - S_2	Data Select Inputs
A_0 - A_7	A Data Inputs
B_0 - B_7	B Data Inputs
Z_a , Z_b	Data Outputs

Connection Diagrams

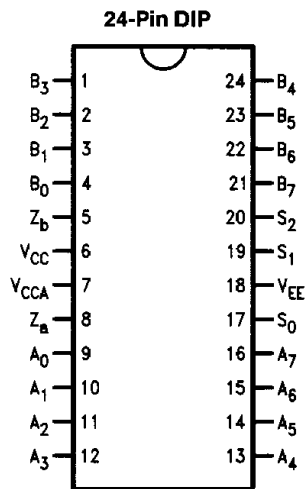

TL/F/9864-1

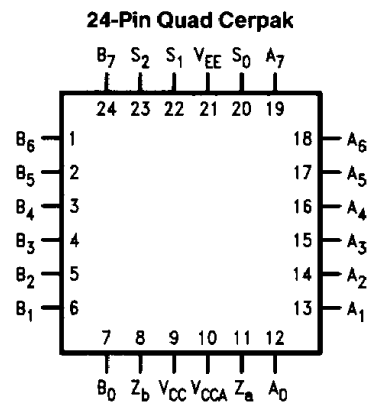

TL/F/9864-2

Logic Diagram

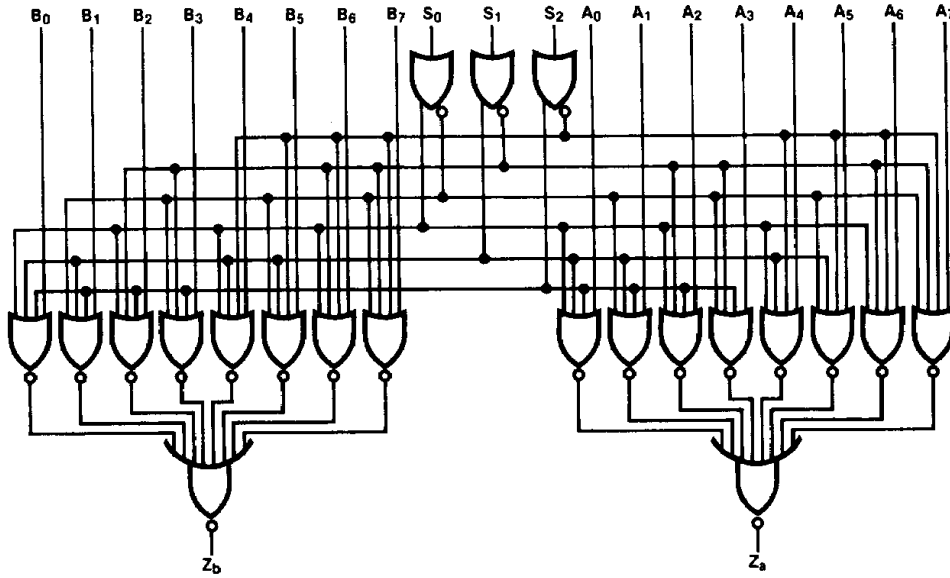

TL/F/9864-5

Truth Table

Inputs											Outputs
Select			Data								
S ₂	S ₁	S ₀	A ₇ B ₇	A ₆ B ₆	A ₅ B ₅	A ₄ B ₄	A ₃ B ₃	A ₂ B ₂	A ₁ B ₁	A ₀ B ₀	Z _a Z _b
L	L	L								L	L
L	L	L								H	H
L	L	H							L		L
L	L	H							H		H
L	H	L						L			L
L	H	L						H			H
L	H	H					L				L
L	H	H					H				H
H	L	L				L					L
H	L	L				H					H
H	L	H			L						L
H	L	H			H						H
H	H	L		L							L
H	H	L		H							H
H	H	H	L								L
H	H	H	H								H

H = HIGH Voltage Level
 L = LOW Voltage Level
 Blank = X = Don't Care

Absolute Maximum Ratings

Above which the useful life may be impaired. (Note 1)

If Military/Aerospace specified devices are required, please contact the National Semiconductor Sales Office/Distributors for availability and specifications.

Storage Temperature -65°C to $+150^{\circ}\text{C}$
 Maximum Junction Temperature (T_J) $+150^{\circ}\text{C}$

Case Temperature under Bias (T_C) 0°C to $+85^{\circ}\text{C}$
 V_{EE} Pin Potential to Ground Pin -7.0V to $+0.5\text{V}$
 Input Voltage (DC) V_{EE} to $+0.5\text{V}$
 Output Current (DC Output HIGH) -50 mA
 Operating Range (Note 2) -5.7V to -4.2V

DC Electrical Characteristics

$V_{EE} = -4.5\text{V}$, $V_{CC} = V_{CCA} = \text{GND}$, $T_C = 0^{\circ}\text{C}$ to $+85^{\circ}\text{C}$ (Note 3)

Symbol	Parameter	Min	Typ	Max	Units	Conditions (Note 4)	
V_{OH}	Output HIGH Voltage	-1025	-955	-880	mV	$V_{IN} = V_{IH}(\text{Max})$ or $V_{IL}(\text{Min})$	Loading with 50Ω to -2.0V
V_{OL}	Output LOW Voltage	-1810	-1705	-1620			
V_{OHC}	Output HIGH Voltage	-1035			mV	$V_{IN} = V_{IH}(\text{Min})$ or $V_{IL}(\text{Max})$	Loading with 50Ω to -2.0V
V_{OLC}	Output LOW Voltage			-1610			
V_{IH}	Input HIGH Voltage	-1165		-880	mV	Guaranteed HIGH Signal for All Inputs	
V_{IL}	Input LOW Voltage	-1810		-1475	mV	Guaranteed LOW Signal for All Inputs	
I_{IL}	Input LOW Current	0.50			μA	$V_{IN} = V_{IL}(\text{Min})$	

DC Electrical Characteristics

$V_{EE} = -4.2\text{V}$, $V_{CC} = V_{CCA} = \text{GND}$, $T_C = 0^{\circ}\text{C}$ to $+85^{\circ}\text{C}$ (Note 3)

Symbol	Parameter	Min	Typ	Max	Units	Conditions (Note 4)	
V_{OH}	Output HIGH Voltage	-1020		-870	mV	$V_{IN} = V_{IH}(\text{Max})$ or $V_{IL}(\text{Min})$	Loading with 50Ω to -2.0V
V_{OL}	Output LOW Voltage	-1810		-1605			
V_{OHC}	Output HIGH Voltage	-1030			mV	$V_{IN} = V_{IH}(\text{Min})$ or $V_{IL}(\text{Max})$	Loading with 50Ω to -2.0V
V_{OLC}	Output LOW Voltage			-1595			
V_{IH}	Input HIGH Voltage	-1150		-870	mV	Guaranteed HIGH Signal for All Inputs	
V_{IL}	Input LOW Voltage	-1810		-1475	mV	Guaranteed LOW Signal for All Inputs	
I_{IL}	Input LOW Current	0.50			μA	$V_{IN} = V_{IL}(\text{Min})$	

DC Electrical Characteristics

$V_{EE} = -4.8\text{V}$, $V_{CC} = V_{CCA} = \text{GND}$, $T_C = 0^{\circ}\text{C}$ to $+85^{\circ}\text{C}$ (Note 3)

Symbol	Parameter	Min	Typ	Max	Units	Conditions (Note 4)	
V_{OH}	Output HIGH Voltage	-1035		-880	mV	$V_{IN} = V_{IH}(\text{Max})$ or $V_{IL}(\text{Min})$	Loading with 50Ω to -2.0V
V_{OL}	Output LOW Voltage	-1830		-1620			
V_{OHC}	Output HIGH Voltage	-1045			mV	$V_{IN} = V_{IH}(\text{Min})$ or $V_{IL}(\text{Max})$	Loading with 50Ω to -2.0V
V_{OLC}	Output LOW Voltage			-1610			
V_{IH}	Input HIGH Voltage	-1165		-880	mV	Guaranteed HIGH Signal for All Inputs	
V_{IL}	Input LOW Voltage	-1830		-1490	mV	Guaranteed LOW Signal for All Inputs	
I_{IL}	Input LOW Current	0.50			μA	$V_{IN} = V_{IL}(\text{Min})$	

Note 1: Absolute maximum ratings are those values beyond which the device may be damaged or have its useful life impaired. Functional operation under these conditions is not implied.

Note 2: Parametric values specified at -4.2V to -4.8V .

Note 3: The specified limits represent the "worst case" value for the parameter. Since these "worst case" values normally occur at the temperature extremes, additional noise immunity and guard banding can be achieved by decreasing the allowable system operating ranges.

Note 4: Conditions for testing shown in the tables are chosen to guarantee operation under "worst case" conditions.

DC Electrical Characteristics
 $V_{EE} = -4.2V$ to $-4.8V$ unless otherwise specified, $V_{CC} = V_{CCA} = GND$, $T_C = 0^\circ C$ to $+85^\circ C$

Symbol	Parameter	Min	Typ	Max	Units	Conditions
I_{IH}	Input HIGH Current S_n A_n, B_n			265 340	μA	$V_{IN} = V_{IH} (Max)$
I_{EE}	Power Supply Current	-153	-110	-76	mA	Inputs Open

Ceramic Dual-In-Line Package AC Electrical Characteristics
 $V_{EE} = -4.2V$ to $-4.8V$, $V_{CC} = V_{CCA} = GND$

Symbol	Parameter	$T_C = 0^\circ C$		$T_C = +25^\circ C$		$T_C = +85^\circ C$		Units	Conditions
		Min	Max	Min	Max	Min	Max		
t_{PLH} t_{PHL}	Propagation Delay A_0-A_7, B_0-B_7 to Output	0.55	1.65	0.60	1.70	0.65	1.80	ns	<i>Figures 1 & 2</i>
t_{PLH} t_{PHL}	Propagation Delay S_0-S_2 to Output	1.10	2.80	1.10	2.80	1.20	3.10	ns	
t_{TLH} t_{THL}	Transition Time 20% to 80%, 80% to 20%	0.50	1.85	0.55	1.80	0.50	1.80	ns	

Cerpak AC Electrical Characteristics
 $V_{EE} = -4.2V$ to $-4.8V$, $V_{CC} = V_{CCA} = GND$

Symbol	Parameter	$T_C = 0^\circ C$		$T_C = +25^\circ C$		$T_C = +85^\circ C$		Units	Conditions
		Min	Max	Min	Max	Min	Max		
t_{PLH} t_{PHL}	Propagation Delay A_0-A_7, B_0-B_7 to Output	0.55	1.45	0.60	1.50	0.65	1.60	ns	<i>Figures 1 & 2</i>
t_{PLH} t_{PHL}	Propagation Delay S_0-S_2 to Output	1.10	2.60	1.10	2.60	1.20	2.90	ns	
t_{TLH} t_{THL}	Transition Time 20% to 80%, 80% to 20%	0.50	1.75	0.55	1.70	0.50	1.70	ns	

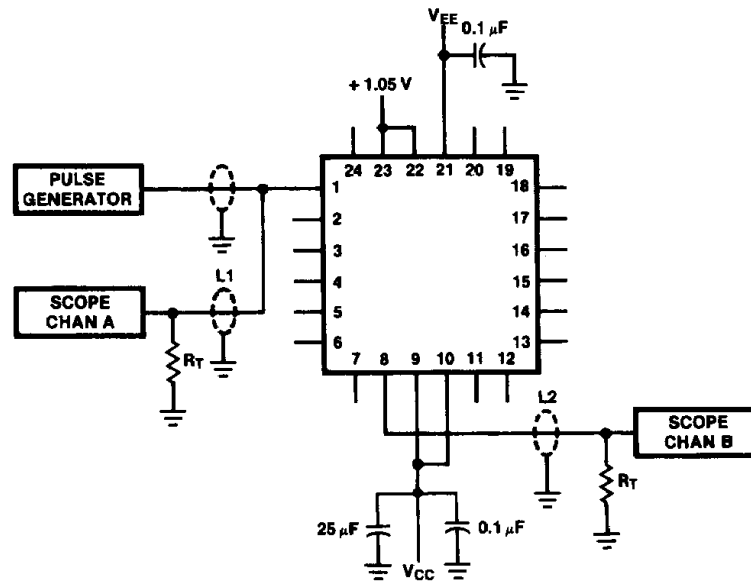

FIGURE 1. AC Test Circuit

TL/F/9864-6

Notes:

- V_{CC}, V_{CCA} = +2V, V_{EE} = -2.5V
- L1 and L2 = equal length 50Ω impedance lines
- R_T = 50Ω terminator internal to scope
- Decoupling 0.1 μF from GND to V_{CC} and V_{EE}
- All unused outputs are loaded with 50Ω to GND
- C_L = Fixture and stray capacitance ≤ 3 pF
- Pin numbers shown are for flatpak; for DIP see logic symbol

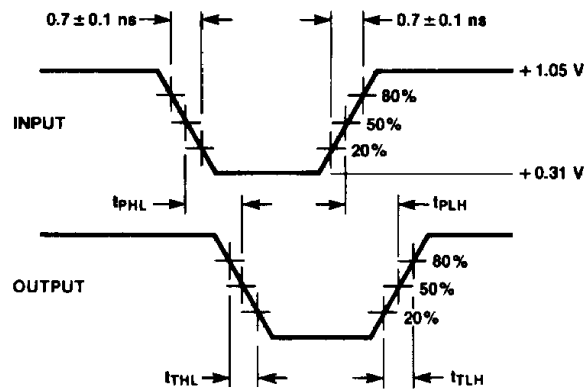

FIGURE 2. Propagation Delay and Transition Times

TL/F/9864-7