

F100170 Universal Demultiplexer/Decoder

General Description

The F100170 universal demultiplexer/decoder functions as either a dual 1-of-4 decoder or as a single 1-of-8 decoder, depending on the signal applied to the Mode Control (M) input. In the dual mode, each half has a pair of active-LOW Enable (\bar{E}) inputs. Pin assignments for the \bar{E} inputs are such that in the 1-of-8 mode they can easily be tied together in pairs to provide two active-LOW enables (\bar{E}_{1a} to \bar{E}_{1b} , \bar{E}_{2a} to \bar{E}_{2b}). Signals applied to auxiliary inputs H_a , H_b and H_c determine whether the outputs are active HIGH or active LOW. In the dual 1-of-4 mode the Address inputs are A_{0a} , A_{1a} and

A_{0b} , A_{1b} with A_{2a} unused (i.e., left open, tied to V_{EE} or with LOW signal applied). In the 1-of-8 mode, the Address inputs are A_{0a} , A_{1a} , A_{2a} with A_{0b} and A_{1b} LOW or open. All inputs have 50 k Ω pulldown resistors.

Refer to the F100370 datasheet for:

- PCC packaging
- Lower power
- Military versions
- Extended voltage specs (-4.2V to -5.7V)

Ordering Code: See Section 8

Logic Symbols

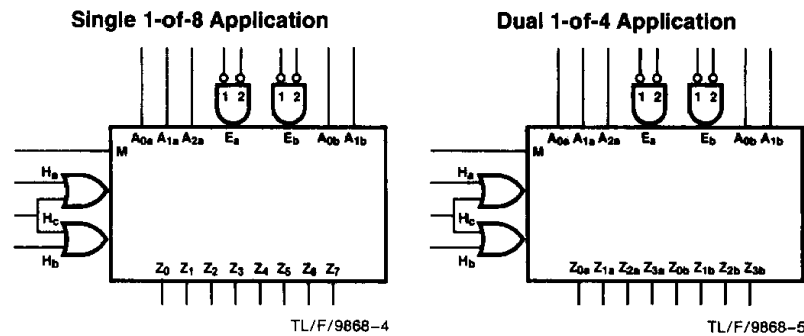

Pin Names	Description
A_{na} , A_{nb}	Address Inputs
\bar{E}_{na} , \bar{E}_{nb}	Enable Inputs
M	Mode Control Input
H_a	Z_0-Z_3 ($\bar{Z}_{0a}-\bar{Z}_{3a}$) Polarity Select Input
H_b	Z_4-Z_7 ($\bar{Z}_{0b}-\bar{Z}_{3b}$) Polarity Select Input
H_c	Common Polarity Select Input
Z_0-Z_7	Single 1-of-8 Data Outputs
Z_{na} , Z_{nb}	Dual 1-of-4 Data Outputs

Connection Diagrams

24-Pin DIP

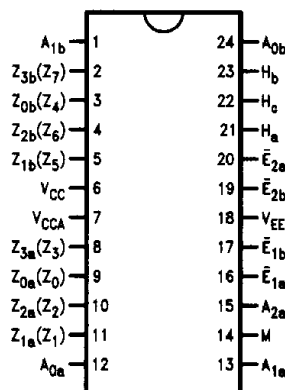

TL/F/9868-1

24-Pin Quad Cerpak

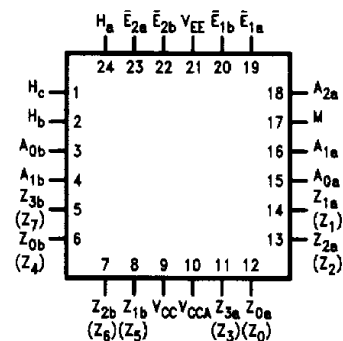

TL/F/9868-2

Logic Diagram

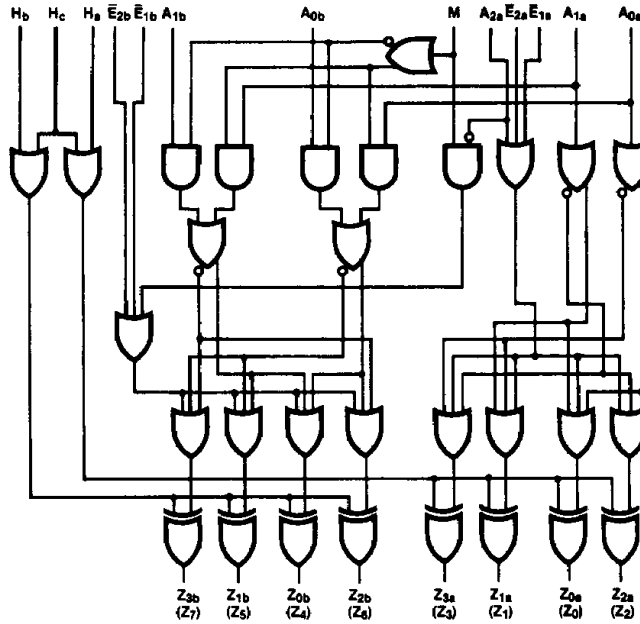

TL/F/9868-6

Note: (Z_n) for 1-of-4 applications.

Truth Tables

Dual 1-of-4 Mode (M = A_{2a} = H_c = LOW)

Inputs				Active HIGH Outputs (H _a and H _b Inputs HIGH)				Active LOW Outputs (H _a and H _b Inputs LOW)			
\bar{E}_{1a}	\bar{E}_{2a}	A _{1a}	A _{0a}	Z _{0a}	Z _{1a}	Z _{2a}	Z _{3a}	Z _{0a}	Z _{1a}	Z _{2a}	Z _{3a}
\bar{E}_{1b}	\bar{E}_{2b}	A _{1b}	A _{0b}	Z _{0b}	Z _{1b}	Z _{2b}	Z _{3b}	Z _{0b}	Z _{1b}	Z _{2b}	Z _{3b}
H	X	X	X	L	L	L	L	H	H	H	H
X	H	X	X	L	L	L	L	H	H	H	H
L	L	L	L	H	L	L	L	L	H	H	H
L	L	L	H	L	H	L	L	H	L	H	H
L	L	H	L	L	L	H	L	H	H	L	H
L	L	H	H	L	L	L	H	H	H	H	L

Single 1-of-8 Mode (M = HIGH; A_{0b} = A_{1b} = H_a = H_b = LOW)

Inputs					Active HIGH Outputs* (H _c Input HIGH)							
\bar{E}_1	\bar{E}_2	A _{2a}	A _{1a}	A _{0a}	Z ₀	Z ₁	Z ₂	Z ₃	Z ₄	Z ₅	Z ₆	Z ₇
H	X	X	X	X	L	L	L	L	L	L	L	L
X	H	X	X	X	L	L	L	L	L	L	L	L
L	L	L	L	L	H	L	L	L	L	L	L	L
L	L	L	L	H	L	H	L	L	L	L	L	L
L	L	L	H	L	L	L	H	L	L	L	L	L
L	L	L	H	H	L	L	L	H	L	L	L	L
L	L	H	L	L	L	L	L	L	H	L	L	L
L	L	H	L	H	L	L	L	L	L	H	L	L
L	L	H	H	L	L	L	L	L	L	L	H	L
L	L	H	H	H	L	L	L	L	L	L	L	H

H = HIGH Voltage Level
 L = LOW Voltage Level
 X = Don't Care
 *for H_c = LOW, output states are complemented
 $\bar{E}_1 = \bar{E}_{1a}$ and \bar{E}_{1b} wired; $\bar{E}_2 = \bar{E}_{2a}$ and \bar{E}_{2b} wired

Absolute Maximum Ratings

Above which the useful life may be impaired. (Note 1)

If Military/Aerospace specified devices are required, please contact the National Semiconductor Sales Office/Distributors for availability and specifications.

Storage Temperature -65°C to $+150^{\circ}\text{C}$
 Maximum Junction Temperature (T_J) $+150^{\circ}\text{C}$

Case Temperature under Bias (T_C) 0°C to $+85^{\circ}\text{C}$
 V_{EE} Pin Potential to Ground Pin -7.0V to $+0.5\text{V}$
 Input Voltage (DC) V_{EE} to $+0.5\text{V}$
 Output Current (DC Output HIGH) -50mA
 Operating Range (Note 2) -5.7V to -4.2V

DC Electrical Characteristics

$V_{EE} = -4.5\text{V}$, $V_{CC} = V_{CCA} = \text{GND}$, $T_C = 0^{\circ}\text{C}$ to $+85^{\circ}\text{C}$ (Note 3)

Symbol	Parameter	Min	Typ	Max	Units	Conditions (Note 4)	
V_{OH}	Output HIGH Voltage	-1025	-955	-880	mV	$V_{IN} = V_{IH}(\text{Max})$ or $V_{IL}(\text{Min})$	Loading with 50Ω to -2.0V
V_{OL}	Output LOW Voltage	-1810	-1705	-1620			
V_{OHC}	Output HIGH Voltage	-1035			mV	$V_{IN} = V_{IH}(\text{Min})$ or $V_{IL}(\text{Max})$	Loading with 50Ω to -2.0V
V_{OLC}	Output LOW Voltage			-1610			
V_{IH}	Input HIGH Voltage	-1165		-880	mV	Guaranteed HIGH Signal for All Inputs	
V_{IL}	Input LOW Voltage	-1810		-1475	mV	Guaranteed LOW Signal for All Inputs	
I_{IL}	Input LOW Current	0.50			μA	$V_{IN} = V_{IL}(\text{Min})$	

DC Electrical Characteristics

$V_{EE} = -4.2\text{V}$, $V_{CC} = V_{CCA} = \text{GND}$, $T_C = 0^{\circ}\text{C}$ to $+85^{\circ}\text{C}$ (Note 3)

Symbol	Parameter	Min	Typ	Max	Units	Conditions (Note 4)	
V_{OH}	Output HIGH Voltage	-1020		-870	mV	$V_{IN} = V_{IH}(\text{Max})$ or $V_{IL}(\text{Min})$	Loading with 50Ω to -2.0V
V_{OL}	Output LOW Voltage	-1810		-1605			
V_{OHC}	Output HIGH Voltage	-1030			mV	$V_{IN} = V_{IH}(\text{Min})$ or $V_{IL}(\text{Max})$	Loading with 50Ω to -2.0V
V_{OLC}	Output LOW Voltage			-1595			
V_{IH}	Input HIGH Voltage	-1150		-870	mV	Guaranteed HIGH Signal for All Inputs	
V_{IL}	Input LOW Voltage	-1810		-1475	mV	Guaranteed LOW Signal for All Inputs	
I_{IL}	Input LOW Current	0.50			μA	$V_{IN} = V_{IL}(\text{Min})$	

DC Electrical Characteristics

$V_{EE} = -4.8\text{V}$, $V_{CC} = V_{CCA} = \text{GND}$, $T_C = 0^{\circ}\text{C}$ to $+85^{\circ}\text{C}$ (Note 3)

Symbol	Parameter	Min	Typ	Max	Units	Conditions (Note 4)	
V_{OH}	Output HIGH Voltage	-1035		-880	mV	$V_{IN} = V_{IH}(\text{Max})$ or $V_{IL}(\text{Min})$	Loading with 50Ω to -2.0V
V_{OL}	Output LOW Voltage	-1830		-1620			
V_{OHC}	Output HIGH Voltage	-1045			mV	$V_{IN} = V_{IH}(\text{Min})$ or $V_{IL}(\text{Max})$	Loading with 50Ω to -2.0V
V_{OLC}	Output LOW Voltage			-1610			
V_{IH}	Input HIGH Voltage	-1165		-880	mV	Guaranteed HIGH Signal for All Inputs	
V_{IL}	Input LOW Voltage	-1830		-1490	mV	Guaranteed LOW Signal for All Inputs	
I_{IL}	Input LOW Current	0.50			μA	$V_{IN} = V_{IL}(\text{Min})$	

Note 1: Absolute maximum ratings are those values beyond which the device may be damaged or have its useful life impaired. Functional operation under these conditions is not implied.

Note 2: Parametric values specified at -4.2V to -4.8V .

Note 3: The specified limits represent the "worst case" value for the parameter. Since these "worst case" values normally occur at the temperature extremes, additional noise immunity and guard banding can be achieved by decreasing the allowable system operating ranges.

Note 4: Conditions for testing shown in the tables are chosen to guarantee operation under "worst case" conditions.

DC Electrical Characteristics $V_{EE} = -4.2V$ to $-4.8V$ unless otherwise specified, $V_{CC} = V_{CCA} = GND$, $T_C = 0^\circ C$ to $+85^\circ C$

Symbol	Parameter	Min	Typ	Max	Units	Conditions
I_{IH}	Input HIGH Current $H_C, A_{0a}, A_{1a}, A_{2a}$ All Others			310 250	μA	$V_{IN} = V_{IH} (Max)$
I_{EE}	Power Supply Current	-153	-109	-76	mA	Inputs Open

Ceramic Dual-In-Line Package AC Electrical Characteristics $V_{EE} = -4.2V$ to $-4.8V$, $V_{CC} = V_{CCA} = GND$

Symbol	Parameter	$T_C = 0^\circ C$		$T_C = +25^\circ C$		$T_C = +85^\circ C$		Units	Conditions
		Min	Max	Min	Max	Min	Max		
t_{PLH} t_{PHL}	Propagation Delay $\bar{E}_{na}, \bar{E}_{nb}$ to Output	0.90	2.30	0.90	2.20	0.90	2.30	ns	<i>Figures 1 and 2</i>
t_{PLH} t_{PHL}	Propagation Delay A_{na}, A_{nb} to Output	1.00	2.80	1.00	2.70	1.00	2.90	ns	
t_{PLH} t_{PHL}	Propagation Delay H_a, H_b, H_c to Output	1.00	3.00	1.00	2.90	1.00	3.00	ns	
t_{PLH} t_{PHL}	Propagation Delay M to Output	1.50	3.90	1.60	3.80	1.60	3.90	ns	
t_{TLH} t_{THL}	Transition Time 20% to 80%, 80% to 20%	0.45	1.70	0.45	1.70	0.45	1.80	ns	

Cerpak AC Electrical Characteristics $V_{EE} = -4.2V$ to $-4.8V$, $V_{CC} = V_{CCA} = GND$

Symbol	Parameter	$T_C = 0^\circ C$		$T_C = +25^\circ C$		$T_C = +85^\circ C$		Units	Conditions
		Min	Max	Min	Max	Min	Max		
t_{PLH} t_{PHL}	Propagation Delay $\bar{E}_{na}, \bar{E}_{nb}$ to Output	0.90	2.10	0.90	2.00	0.90	2.10	ns	<i>Figures 1 and 2</i>
t_{PLH} t_{PHL}	Propagation Delay A_{na}, A_{nb} to Output	1.00	2.60	1.00	2.50	1.00	2.70	ns	
t_{PLH} t_{PHL}	Propagation Delay H_a, H_b, H_c to Output	1.00	2.80	1.00	2.70	1.00	2.80	ns	
t_{PLH} t_{PHL}	Propagation Delay M to Output	1.50	3.70	1.60	3.60	1.60	3.70	ns	
t_{TLH} t_{THL}	Transition Time 20% to 80%, 80% to 20%	0.45	1.60	0.45	1.60	0.45	1.70	ns	

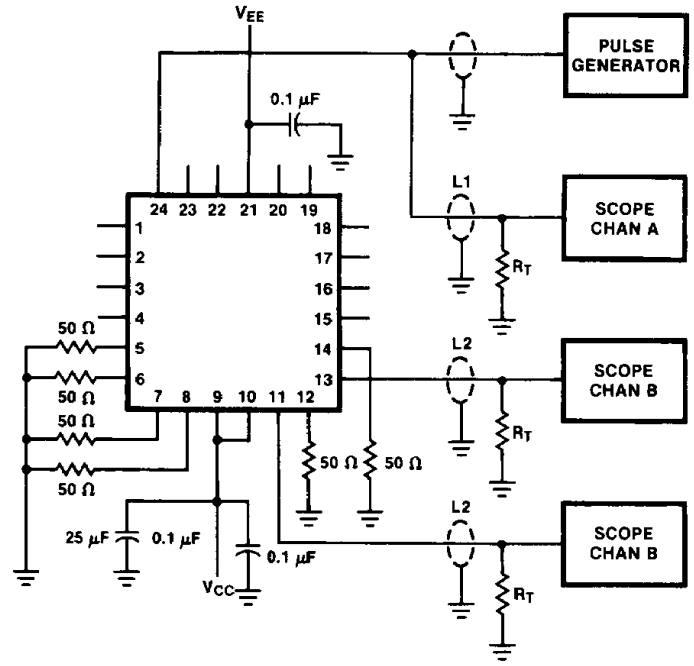

TL/F/9868-7

FIGURE 1. AC Test Circuit

- Notes:**
 V_{CC}, V_{CCA} = +2V, V_{EE} = -2.5V
 L1 and L2 = equal length 50Ω impedance lines
 R_T = 50Ω terminator internal to scope
 Decoupling 0.1 μF from GND to V_{CC} and V_{EE}
 All unused outputs are loaded with 50Ω to GND
 C_L = Fixture and stray capacitance ≤ 3 pF
 Pin numbers shown are for flatpak; for DIP see logic symbol

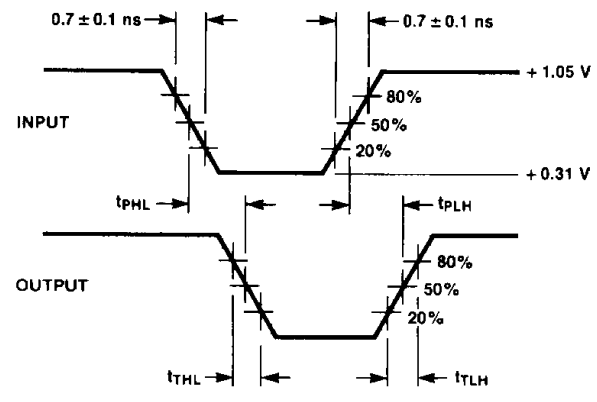

TL/F/9868-8

FIGURE 2. Propagation Delay and Transition Times