

# F100336

## Low Power 4-Stage Counter/Shift Register

### General Description

The F100336 operates as either a modulo-16 up/down counter or as a 4-bit bidirectional shift register. Three Select ( $S_n$ ) inputs determine the mode of operation, as shown in the Function Select table. Two Count Enable ( $\overline{CEP}$ ,  $\overline{CET}$ ) inputs are provided for ease of cascading in multistage counters. One Count Enable ( $\overline{CET}$ ) input also doubles as a Serial Data ( $D_0$ ) input for shift-up operation. For shift-down operation,  $D_3$  is the Serial Data input. In counting operations the Terminal Count ( $\overline{TC}$ ) output goes LOW when the counter reaches 15 in the count/up mode or 0 (zero) in the count/down mode. In the shift modes, the  $\overline{TC}$  output repeats the  $Q_3$  output. The dual nature of this  $\overline{TC}/Q_3$  output and the  $D_0/\overline{CET}$  input means that one interconnection from one stage to the next higher stage serves as the link for

multistage counting or shift-up operation. The individual Preset ( $P_n$ ) inputs are used to enter data in parallel or to preset the counter in programmable counter applications. A HIGH signal on the Master Reset ( $MR$ ) input overrides all other inputs and asynchronously clears the flip-flops. In addition, a synchronous clear is provided, as well as a complement function which synchronously inverts the contents of the flip-flops. All inputs have 50 k $\Omega$  pull-down resistors.

### Features

- 30% power reduction of the F100136
- 2000V ESD protection
- Pin/function compatible with F100136
- Voltage compensated operating range = -4.2V to -5.7V

**Ordering Code:** See Section 8

### Logic Symbol

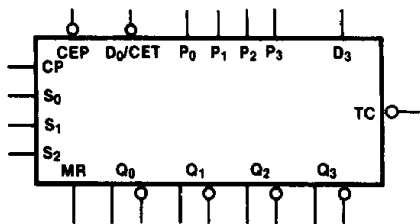

TL/F/10584-1

Pin Names	Description
CP	Clock Pulse Input
$\overline{CEP}$	Count Enable Parallel Input (Active LOW)
$D_0/\overline{CET}$	Serial Data Input/Count Enable Trickle Input (Active LOW)
$S_0-S_2$	Select Inputs
MR	Master Reset Input
$P_0-P_3$	Preset Inputs
$D_3$	Serial Data Input
$\overline{TC}$	Terminal Count Output
$Q_0-Q_3$	Data Outputs
$\overline{Q}_0-\overline{Q}_3$	Complementary Data Outputs

### Connection Diagrams

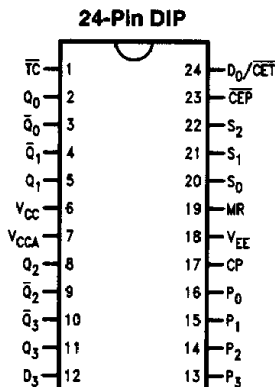

TL/F/10584-2

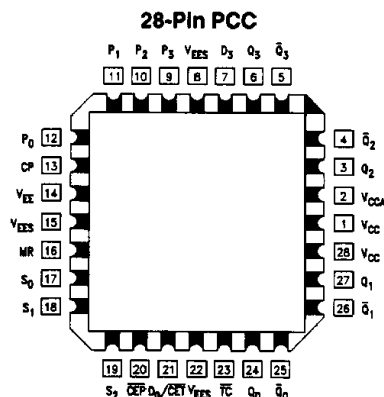

TL/F/10584-4

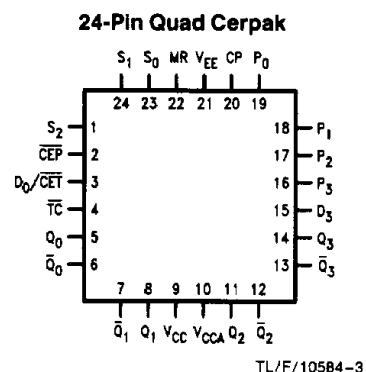

TL/F/10584-3

# Logic Diagram

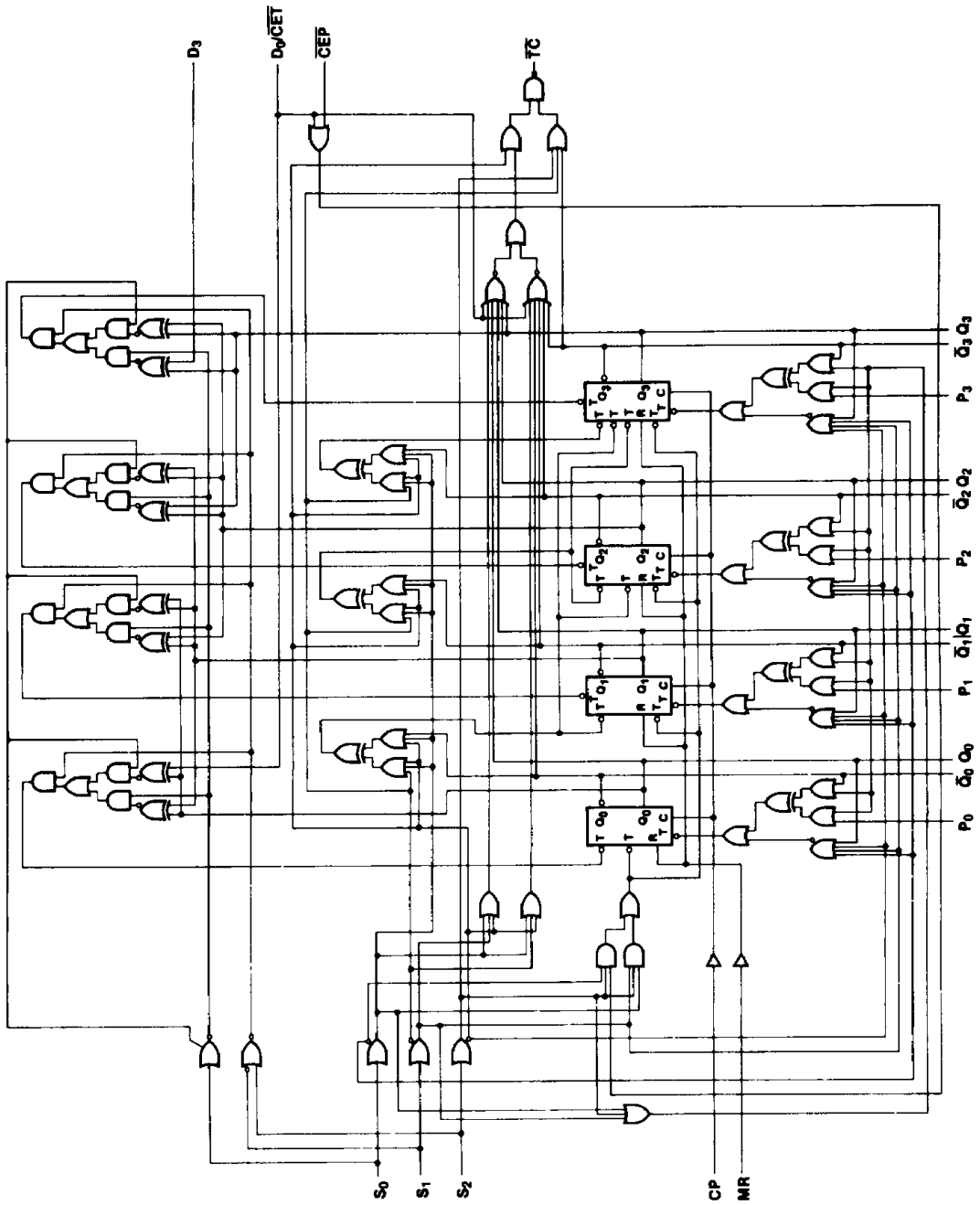

TL/F/10584-5

Function Select Table

S <sub>2</sub>	S <sub>1</sub>	S <sub>0</sub>	Function
L	L	L	Parallel Load
L	L	H	Complement
L	H	L	Shift Left
L	H	H	Shift Right
H	L	L	Count Down
H	L	H	Clear
H	H	L	Count Up
H	H	H	Hold

Truth Table

Q<sub>0</sub> = LSB

Inputs								Outputs					Mode
MR	S <sub>2</sub>	S <sub>1</sub>	S <sub>0</sub>	$\overline{\text{CEP}}$	D <sub>0</sub> / $\overline{\text{CET}}$	D <sub>3</sub>	CP	Q <sub>3</sub>	Q <sub>2</sub>	Q <sub>1</sub>	Q <sub>0</sub>	TC	
L	L	L	L	X	X	X	$\nearrow$	P <sub>3</sub>	P <sub>2</sub>	P <sub>1</sub>	P <sub>0</sub>	L	Preset (Parallel Load)
L	L	L	H	X	X	X	$\nearrow$	$\overline{\text{Q}}_3$	$\overline{\text{Q}}_2$	$\overline{\text{Q}}_1$	$\overline{\text{Q}}_0$	L	Invert
L	L	H	L	X	X	X	$\nearrow$	D <sub>3</sub>	Q <sub>3</sub>	Q <sub>2</sub>	Q <sub>1</sub>	D <sub>3</sub>	Shift Left
L	L	H	H	X	X	X	$\nearrow$	Q <sub>2</sub>	Q <sub>1</sub>	Q <sub>0</sub>	D <sub>0</sub>	Q <sub>3</sub> *	Shift Right
L	H	L	L	L	L	X	$\nearrow$	(Q <sub>0-3</sub> ) minus 1				⊖	Count Down
L	H	L	L	H	L	X	X	Q <sub>3</sub>	Q <sub>2</sub>	Q <sub>1</sub>	Q <sub>0</sub>	⊖	Count Down with $\overline{\text{CEP}}$ not active
L	H	L	L	X	H	X	X	Q <sub>3</sub>	Q <sub>2</sub>	Q <sub>1</sub>	Q <sub>0</sub>	H	Count Down with $\overline{\text{CET}}$ not active
L	H	L	H	X	X	X	$\nearrow$	L	L	L	L	H	Clear
L	H	H	L	L	L	X	$\nearrow$	(Q <sub>0-3</sub> ) plus 1				⊕	Count Up
L	H	H	L	H	L	X	X	Q <sub>3</sub>	Q <sub>2</sub>	Q <sub>1</sub>	Q <sub>0</sub>	⊕	Count Up with $\overline{\text{CEP}}$ not active
L	H	H	L	X	H	X	X	Q <sub>3</sub>	Q <sub>2</sub>	Q <sub>1</sub>	Q <sub>0</sub>	H	Count Up with $\overline{\text{CET}}$ not active
L	H	H	H	X	X	X	X	Q <sub>3</sub>	Q <sub>2</sub>	Q <sub>1</sub>	Q <sub>0</sub>	H	Hold
H	L	L	L	X	X	X	X	L	L	L	L	L	Asynchronous Master Reset
H	L	L	H	X	X	X	X	L	L	L	L	L	
H	L	H	L	X	X	X	X	L	L	L	L	L	
H	L	H	H	X	X	X	X	L	L	L	L	L	
H	H	L	L	X	L	X	X	L	L	L	L	L	
H	H	L	H	X	H	X	X	L	L	L	L	H	
H	H	H	L	X	X	X	X	L	L	L	L	H	
H	H	H	H	X	X	X	X	L	L	L	L	H	

⊖ = L if Q<sub>0</sub>-Q<sub>3</sub> = LLLLH if Q<sub>0</sub>-Q<sub>3</sub> ≠ LLLL⊕ = L if Q<sub>0</sub>-Q<sub>3</sub> = HHHHH if Q<sub>0</sub>-Q<sub>3</sub> ≠ HHHH

H = HIGH Voltage Level

L = LOW Voltage Level

X = Don't Care

 $\nearrow$  = LOW-to-HIGH Transition\*Before the clock, TC is Q<sub>3</sub>After the clock, TC is Q<sub>2</sub>

## Absolute Maximum Ratings

Above which the useful life may be impaired. (Note 1)

If Military/Aerospace specified devices are required, please contact the National Semiconductor Sales Office/Distributors for availability and specifications.

Storage Temperature ( $T_{STG}$ )	-65°C to +150°C
Maximum Junction Temperature ( $T_J$ )	
Ceramic	+175°C
Plastic	+150°C
$V_{EE}$ Pin Potential to Ground Pin	-7.0V to +0.5V
Input Voltage (DC)	$V_{EE}$ to +0.5V
Output Current (DC Output HIGH)	-50 mA
ESD (Note 2)	$\geq 2000V$

## Commercial Version

### DC Electrical Characteristics

$V_{EE} = -4.2V$  to  $-5.7V$ ,  $V_{CC} = V_{CCA} = GND$ ,  $T_C = 0^\circ C$  to  $+85^\circ C$  (Note 3)

Symbol	Parameter	Min	Typ	Max	Units	Conditions	
$V_{OH}$	Output HIGH Voltage	-1025	-955	-870	mV	$V_{IN} = V_{IH}(\text{Max})$ or $V_{IL}(\text{Min})$	Loading with 50 $\Omega$ to -2.0V
$V_{OL}$	Output LOW Voltage	-1830	-1705	-1620	mV		
$V_{OHC}$	Output HIGH Voltage	-1035			mV	$V_{IN} = V_{IH}(\text{Min})$ or $V_{IL}(\text{Max})$	Loading with 50 $\Omega$ to -2.0V
$V_{OLC}$	Output LOW Voltage			-1610	mV		
$V_{IH}$	Input HIGH Voltage	-1165		-870	mV	Guaranteed HIGH Signal for All Inputs	
$V_{IL}$	Input LOW Voltage	-1830		-1475	mV	Guaranteed LOW Signal for All Inputs	
$I_{IL}$	Input LOW Current	0.50			$\mu A$	$V_{IN} = V_{IL}(\text{Min})$	
$I_{IH}$	Input HIGH Current			240	$\mu A$	$V_{IN} = V_{IH}(\text{Max})$	
$I_{EE}$	Power Supply Current	-198 -220		-100 -100	mA	Inputs Open $V_{EE} = -4.2V$ to $-4.8V$ $V_{EE} = -4.2V$ to $-5.7V$	

**Note 1:** Absolute maximum ratings are those values beyond which the device may be damaged or have its useful life impaired. Functional operation under these conditions is not implied.

**Note 2:** ESD testing conforms to MIL-STD-883, Method 3015.

**Note 3:** The specified limits represent the "worst case" value for the parameter. Since these values normally occur at the temperature extremes, additional noise immunity and guardbanding can be achieved by decreasing the allowable system operating ranges. Conditions for testing shown in the tables are chosen to guarantee operation under "worst case" conditions.

## Recommended Operating Conditions

Case Temperature ( $T_C$ )	
Commercial	0°C to +85°C
Military	-55°C to +125°C
Supply Voltage ( $V_{EE}$ )	
Commercial	-5.7V to -4.2V
Military	-5.7V to -4.2V

**Commercial Version** (Continued)**Ceramic Dual-In-Line Package AC Characteristics** $V_{EE} = -4.2V$  to  $-5.7V$ ,  $V_{CC} = V_{CCA} = GND$ 

Symbol	Parameter	$T_C = 0^\circ C$		$T_C = +25^\circ C$		$T_C = +85^\circ C$		Units	Conditions
		Min	Max	Min	Max	Min	Max		
$f_{shift}$	Shift Frequency	250		250		250		MHz	Figures 2 and 3
$t_{PLH}$ $t_{PHL}$	Propagation Delay CP to $Q_n, \bar{Q}_n$	0.70	1.90	0.70	1.90	0.80	2.00	ns	Figures 1 and 3 (Note 1)
$t_{PLH}$ $t_{PHL}$	Propagation Delay CP to $\bar{T}C$ (Shift)	1.30	3.80	1.30	3.80	1.40	3.90	ns	Figures 1, 7, 8 (Note 1)
$t_{PLH}$ $t_{PHL}$	Propagation Delay CP to $\bar{T}C$ (Count)	1.60	4.60	1.60	4.60	1.60	5.00	ns	Figures 1 and 9 (Note 1)
$t_{PLH}$ $t_{PHL}$	Propagation Delay MR to $Q_n, \bar{Q}_n$	1.10	2.50	1.10	2.50	1.20	2.60	ns	Figures 1 and 4 (Note 1)
$t_{PLH}$ $t_{PHL}$	Propagation Delay MR to $\bar{T}C$ (Count)	2.00	4.00	2.00	4.00	2.20	4.10	ns	Figures 1, 12 (Note 1)
$t_{PHL}$	Propagation Delay MR to $\bar{T}C$ (Shift)	1.60	3.20	1.60	3.20	1.70	3.40	ns	Figures 1, 10, 11 (Note 1)
$t_{PLH}$ $t_{PHL}$	Propagation Delay $D_0/\bar{CET}$ to $\bar{T}C$	1.20	3.20	1.20	3.20	1.40	3.70	ns	Figures 1 and 5 (Note 1)
$t_{PLH}$ $t_{PHL}$	Propagation Delay $S_n$ to $\bar{T}C$	0.90	4.00	0.90	4.20	1.00	4.80	ns	
$t_{TLH}$ $t_{THL}$	Transition Time 20% to 80%, 80% to 20%	0.35	1.20	0.35	1.20	0.35	1.20	ns	Figures 1 and 3
$t_s$	Setup Time $D_3$ $P_n$ $D_0/\bar{CET}$ $\bar{CEP}$ $S_n$ MR (Release Time)	1.00 1.30 1.35 1.90 4.40 2.60		1.00 1.30 1.35 1.90 4.40 2.60		1.00 1.30 1.35 1.90 4.40 2.60		ns	Figure 6
$t_h$	Hold Time $D_3$ $P_n$ $D_0/\bar{CET}$ $\bar{CEP}$ $S_n$	0.40 0.50 0.30 0.40 -0.40		0.40 0.50 0.30 0.40 -0.40		0.40 0.50 0.30 0.40 -0.40		ns	Figure 6
$t_{pw(H)}$	Pulse Width HIGH CP, MR	2.00		2.00		2.00		ns	Figures 3 and 4

**Note 1:** The propagation delay specified is for single output switching. Delays may vary up to 250 ps with multiple outputs switching.

## Commercial Version (Continued)

## PCC and Cerpak AC Electrical Characteristics

 $V_{EE} = -4.2V$  to  $-5.7V$ ,  $V_{CC} = V_{CCA} = GND$ 

Symbol	Parameter	$T_C = 0^\circ C$		$T_C = +25^\circ C$		$T_C = +85^\circ C$		Units	Conditions
		Min	Max	Min	Max	Min	Max		
$f_{shift}$	Shift Frequency	300		300		300		MHz	Figures 2 and 3
$t_{PLH}$ $t_{PHL}$	Propagation Delay CP to $Q_n, \bar{Q}_n$	0.70	1.70	0.70	1.70	0.80	1.80	ns	Figures 1 and 3 (Note 2)
$t_{PLH}$ $t_{PHL}$	Propagation Delay CP to $\bar{TC}$ (Shift)	1.30	3.60	1.30	3.60	1.40	3.70	ns	Figures 1, 7, 8 (Note 2)
$t_{PLH}$ $t_{PHL}$	Propagation Delay CP to $\bar{TC}$ (Count)	1.60	4.40	1.60	4.40	1.60	4.80	ns	Figures 1 and 9 (Note 2)
$t_{PLH}$ $t_{PHL}$	Propagation Delay MR to $Q_n, \bar{Q}_n$	1.10	2.30	1.10	2.30	1.20	2.40	ns	Figures 1 and 4 (Note 2)
$t_{PLH}$ $t_{PHL}$	Propagation Delay MR to $\bar{TC}$ (Count)	2.00	3.80	2.00	3.80	2.20	3.90	ns	Figures 1 and 12 (Note 2)
$t_{PHL}$	Propagation Delay MR to $\bar{TC}$ (Shift)	1.60	3.00	1.60	3.00	1.70	3.20	ns	Figures 1, 10, 11 (Note 2)
$t_{PLH}$ $t_{PHL}$	Propagation Delay $D_0/\overline{CET}$ to $\bar{TC}$	1.20	3.00	1.20	3.00	1.40	3.50	ns	Figures 1 and 5 (Note 2)
$t_{PLH}$ $t_{PHL}$	Propagation Delay $S_n$ to $\bar{TC}$	0.90	3.80	0.90	4.00	1.00	4.60	ns	
$t_{LH}$ $t_{HL}$	Transition Time 20% to 80%, 80% to 20%	0.35	1.10	0.35	1.10	0.35	1.10	ns	Figures 1 and 3
$t_s$	Setup Time $D_3$ $P_n$ $D_0/\overline{CET}$ $\overline{CEP}$ $S_n$ MR (Release Time)	0.90 1.20 1.25 1.80 4.30 2.50		0.90 1.20 1.25 1.80 4.30 2.50		0.90 1.20 1.25 1.80 4.30 2.50		ns	Figure 6
$t_h$	Hold Time $D_3$ $P_n$ $D_0/\overline{CET}$ $\overline{CEP}$ $S_n$	0.30 0.40 0.20 0.30 -0.50		0.30 0.40 0.20 0.30 -0.50		0.30 0.40 0.20 0.30 -0.50		ns	Figure 6
$t_{pw(H)}$	Pulse Width HIGH CP, MR	2.00		2.00		2.00		ns	Figures 3 and 4
$t_{s, G-G}$	Skew, Gate to Gate		TBD		TBD		TBD	ps	PCC Only (Note 1)

**Note 1:** Gate to gate skew is defined as the difference in propagation delays between each of the outputs.

**Note 2:** The propagation delay specified is for single output switching. Delays may vary up to 250 ps with multiple outputs switching.

**Military Version—Preliminary****DC Electrical Characteristics** $V_{EE} = -4.2V$  to  $-5.7V$ ,  $V_{CC} = V_{CCA} = GND$ ,  $T_C = -55^{\circ}C$  to  $+125^{\circ}C$ 

Symbol	Parameter	Min	Max	Units	$T_C$	Conditions	Notes	
$V_{OH}$	Output HIGH Voltage	-1025	-870	mV	$0^{\circ}C$ to $+125^{\circ}C$	$V_{IN} = V_{IH}(\text{Max})$ or $V_{IL}(\text{Min})$	Loading with $50\Omega$ to $-2.0V$	1, 2, 3
		-1085	-870	mV	$-55^{\circ}C$			
$V_{OL}$	Output LOW Voltage	-1830	-1620	mV	$0^{\circ}C$ to $+125^{\circ}C$			
		-1830	-1555	mV	$-55^{\circ}C$			
$V_{OHC}$	Output HIGH Voltage	-1035		mV	$0^{\circ}C$ to $+125^{\circ}C$	$V_{IN} = V_{IH}(\text{Min})$ or $V_{IL}(\text{Max})$	Loading with $50\Omega$ to $-2.0V$	1, 2, 3
		-1085		mV	$-55^{\circ}C$			
$V_{OLC}$	Output LOW Voltage		-1610	mV	$0^{\circ}C$ to $+125^{\circ}C$			
			-1555	mV	$-55^{\circ}C$			
$V_{IH}$	Input HIGH Voltage	-1165	-870	mV	$-55^{\circ}C$ to $+125^{\circ}C$	Guaranteed HIGH Signal for All Inputs	1, 2, 3, 4	
$V_{IL}$	Input LOW Voltage	-1830	-1475	mV	$-55^{\circ}C$ to $+125^{\circ}C$	Guaranteed LOW Signal for All Inputs	1, 2, 3, 4	
$I_{IL}$	Input LOW Current	0.50		$\mu A$	$-55^{\circ}C$ to $+125^{\circ}C$	$V_{EE} = -4.2V$ $V_{IN} = V_{IL}(\text{Min})$	1, 2, 3	
$I_{IH}$	Input HIGH Current		240	$\mu A$	$0^{\circ}C$ to $+125^{\circ}C$	$V_{EE} = -5.7V$ $V_{IN} = V_{IH}(\text{Max})$	1, 2, 3	
			340	$\mu A$	$-55^{\circ}C$			
$I_{EE}$	Power Supply Current	-208 -230	-100 -100	mA	$-55^{\circ}C$ to $+125^{\circ}C$	Inputs Open $V_{EE} = -4.2V$ to $-4.8V$ $V_{EE} = -4.2V$ to $-5.7V$	1, 2, 3	

**Note 1:** F100K 300 Series cold temperature testing is performed by temperature soaking (to guarantee junction temperature equals  $-55^{\circ}C$ ), then testing immediately without allowing for the junction temperature to stabilize due to heat dissipation after power-up. This provides "cold start" specs which can be considered a worst case condition at cold temperatures.

**Note 2:** Screen tested 100% on each device at  $-55^{\circ}C$ ,  $+25^{\circ}C$ , and  $+125^{\circ}C$ , Subgroups 1, 2, 3, 7, and 8.

**Note 3:** Sample tested (Method 5005, Table I) on each manufactured lot at  $-55^{\circ}C$ ,  $+25^{\circ}C$ ,  $+125^{\circ}C$ , Subgroups A1, 2, 3, 7, and 8.

**Note 4:** Guaranteed by applying specified input condition and testing  $V_{OH}/V_{OL}$ .

### Military Version—Preliminary (Continued)

## Ceramic Dual-In-Line Package AC Characteristics

$V_{EE} = -4.2V$  to  $-5.7V$ ,  $V_{CC} = V_{CCA} = GND$

Symbol	Parameter	$T_C = -55^\circ C$		$T_C = +25^\circ C$		$T_C = +125^\circ$		Units	Conditions	Notes
		Min	Max	Min	Max	Min	Max			
$f_{shift}$	Shift Frequency	200		200		200		MHz	Figures 2 and 3	4
$t_{PLH}$ $t_{PHL}$	Propagation Delay CP to $Q_n, \bar{Q}_n$	0.60	2.10	0.60	2.10	0.70	2.20	ns	Figures 1 and 3	1, 2, 3, 5
$t_{PLH}$ $t_{PHL}$	Propagation Delay CP to $\bar{TC}$ (Shift)	1.20	4.00	1.20	4.00	1.30	4.10	ns	Figures 1, 7, 8	
$t_{PLH}$ $t_{PHL}$	Propagation Delay CP to $\bar{TC}$ (Count)	1.50	4.80	1.50	4.80	1.50	5.20	ns	Figures 1 and 9	1, 2, 3, 5
$t_{PLH}$ $t_{PHL}$	Propagation Delay MR to $Q_n, \bar{Q}_n$	1.00	2.70	1.00	2.70	1.10	2.80	ns	Figures 1 and 4	1, 2, 3, 5
$t_{PLH}$ $t_{PHL}$	Propagation Delay MR to $\bar{TC}$ (Count)	1.90	4.20	1.90	4.20	2.10	4.30	ns	Figures 1, 12	
$t_{PHL}$	Propagation Delay MR to $\bar{TC}$ (Shift)	1.50	3.40	1.50	3.40	1.60	3.60	ns	Figures 1, 10, 11	1, 2, 3, 5
$t_{PLH}$ $t_{PHL}$	Propagation Delay $D_0/\bar{CET}$ to $\bar{TC}$	1.10	3.40	1.10	3.40	1.30	3.90	ns	Figures 1 and 5	1, 2, 3, 5
$t_{PLH}$ $t_{PHL}$	Propagation Delay $S_n$ to $\bar{TC}$	0.80	4.20	0.80	4.40	0.90	5.00	ns		
$t_{TLH}$ $t_{THL}$	Transition Time 20% to 80%, 80% to 20%	0.45	1.20	0.35	1.20	0.35	1.20	ns	Figures 1 and 3	4
$t_s$	Setup Time $D_3$ $P_n$ $D_0/\bar{CET}$ $\bar{CEP}$ $S_n$ MR (Release Time)	1.20 1.50 1.55 2.10 4.60 2.80		1.20 1.50 1.55 2.10 4.60 2.80		1.20 1.50 1.55 2.10 4.60 2.80		ns	Figure 6	4
$t_h$	Hold Time $D_3$ $P_n$ $D_0/\bar{CET}$ $\bar{CEP}$ $S_n$	0.60 0.70 0.50 0.60 -0.30		0.60 0.70 0.50 0.60 -0.30		0.60 0.70 0.50 0.60 -0.30		ns	Figure 6	4
$t_{pw(H)}$	Pulse Width HIGH CP, MR	2.20		2.20		2.20		ns	Figures 3 and 4	4

**Note 1:** F100K 300 Series cold temperature testing is performed by temperature soaking (to guarantee junction temperature equals  $-55^\circ C$ ), then testing immediately after power-up. This provides "cold start" specs which can be considered a worst case condition at cold temperatures.

**Note 2:** Screen tested 100% on each device at  $+25^\circ C$  temperature only, Subgroups A9.

**Note 3:** Sample tested (Method 5005, Table I) on each manufactured lot at  $+25^\circ C$ , Subgroups A9, and at  $+125^\circ C$  and  $-55^\circ C$  temperatures, Subgroups A10 and A11.

**Note 4:** Not tested at  $+25^\circ C$ ,  $+125^\circ C$ , and  $-55^\circ C$  temperature (design characterization data).

**Note 5:** The propagation delay specified is for single output switching. Delays may vary up to 250 ps with multiple outputs switching.

**Military Version—Preliminary** (Continued)**Cerpak AC Electrical Characteristics** $V_{EE} = -4.2V$  to  $-5.7V$ ,  $V_{CC} = V_{CCA} = GND$ 

Symbol	Parameter	$T_C = -55^\circ C$		$T_C = +25^\circ C$		$T_C = +125^\circ C$		Units	Conditions	Notes
		Min	Max	Min	Max	Min	Max			
$f_{shift}$	Shift Frequency	200		200		200		MHz	Figures 2 and 3	4
$t_{PLH}$ $t_{PHL}$	Propagation Delay CP to $Q_n, \bar{Q}_n$	0.60	2.10	0.60	2.10	0.70	2.20	ns	Figures 1 and 3	1, 2, 3, 5
$t_{PLH}$ $t_{PHL}$	Propagation Delay CP to $\bar{TC}$ (Shift)	1.20	4.00	1.20	4.00	1.30	4.10	ns	Figures 1, 7, 8	
$t_{PLH}$ $t_{PHL}$	Propagation Delay CP to $\bar{TC}$ (Count)	1.50	4.80	1.50	4.80	1.50	5.20	ns	Figures 1, 9	1, 2, 3, 5
$t_{PLH}$ $t_{PHL}$	Propagation Delay MR to $Q_n, \bar{Q}_n$	1.00	2.70	1.00	2.70	1.10	2.80	ns	Figures 1 and 4	1, 2, 3, 5
$t_{PLH}$ $t_{PHL}$	Propagation Delay MR to $\bar{TC}$ (Count)	1.90	4.20	1.90	4.20	2.10	4.30	ns	Figures 1 and 12	
$t_{PHL}$	Propagation Delay MR to $\bar{TC}$ (Shift)	1.50	3.40	1.50	3.40	1.60	3.60	ns	Figures 1, 10, 11	1, 2, 3, 5
$t_{PLH}$ $t_{PHL}$	Propagation Delay $D_0/\bar{CET}$ to $\bar{TC}$	1.10	3.40	1.10	3.40	1.30	3.90	ns	Figures 1 and 5	1, 2, 3, 5
$t_{PLH}$ $t_{PHL}$	Propagation Delay $S_n$ to $\bar{TC}$	0.80	4.20	0.80	4.40	0.90	5.00	ns		
$t_{TLH}$ $t_{THL}$	Transition Time 20% to 80%, 80% to 20%	0.45	1.10	0.35	1.10	0.35	1.10	ns	Figures 1 and 3	4
$t_s$	Setup Time $D_3$ $P_n$ $D_0/\bar{CET}$ $\bar{CEP}$ $S_n$ MR (Release Time)	1.20 1.50 1.55 2.10 4.60 2.80		1.20 1.50 1.55 2.10 4.60 2.80		1.20 1.50 1.55 2.10 4.60 2.80		ns	Figure 6	4
$t_h$	Hold Time $D_3$ $P_n$ $D_0/\bar{CET}$ $\bar{CEP}$ $S_n$	0.60 0.70 0.50 0.60 -0.30		0.60 0.70 0.50 0.60 -0.30		0.60 0.70 0.50 0.60 -0.30		ns	Figure 6	4
$t_{pw(H)}$	Pulse Width HIGH CP, MR	2.20		2.20		2.20		ns	Figures 3 and 4	4

**Note 1:** F100K 300 Series cold temperature testing is performed by temperature soaking (to guarantee junction temperature equals  $-55^\circ C$ ), then testing immediately after power-up. This provides "cold start" specs which can be considered a worst case condition at cold temperatures.

**Note 2:** Screen tested 100% on each device at  $+25^\circ C$  temperature only, Subgroup A9.

**Note 3:** Sample tested (Method 5005, Table I) on each manufactured lot at  $+25^\circ C$ , Subgroup A9, and at  $+125^\circ C$  and  $-55^\circ C$  temperatures, Subgroups A10 and A11.

**Note 4:** Not tested at  $+25^\circ C$ ,  $+125^\circ C$ , and  $-55^\circ C$  temperature (design characterization data).

**Note 5:** The propagation delay specified is for single output switching. Delays may vary up to 250 ps with multiple outputs switching.

# Test Circuitry

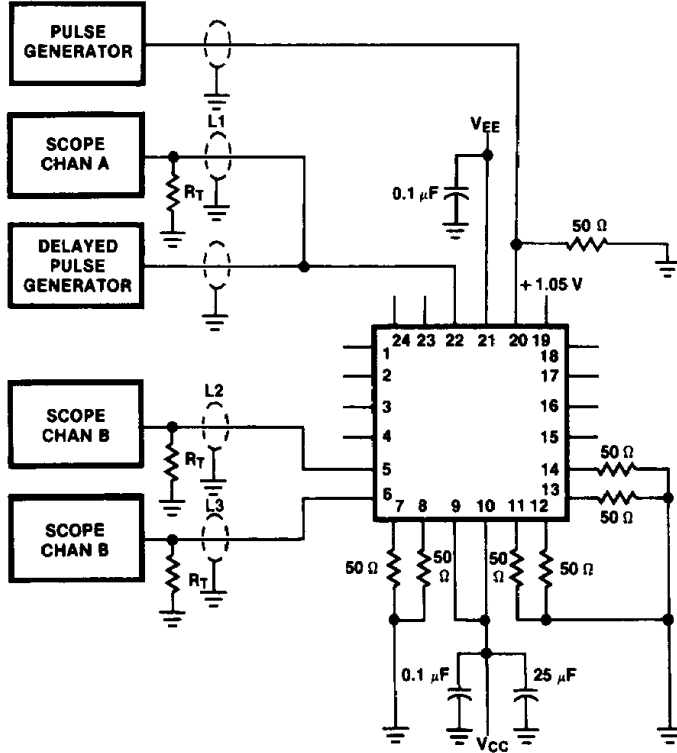

**Notes:**

- $V_{CC}, V_{CCA} = +2V, V_{EE} = -2.5V$
- $L1, L2$  and  $L3 =$  equal length  $50\Omega$  impedance lines
- $R_T = 50\Omega$  terminator internal to scope
- Decoupling  $0.1\mu F$  from GND to  $V_{CC}$  and  $V_{EE}$
- All unused outputs are loaded with  $50\Omega$  to GND
- $C_L =$  Fixture and stray capacitance  $\leq 3 pF$
- Pin numbers shown are for flatpak;  
for DIP see logic symbol

FIGURE 1. AC Test Circuit

TL/F/10584-6

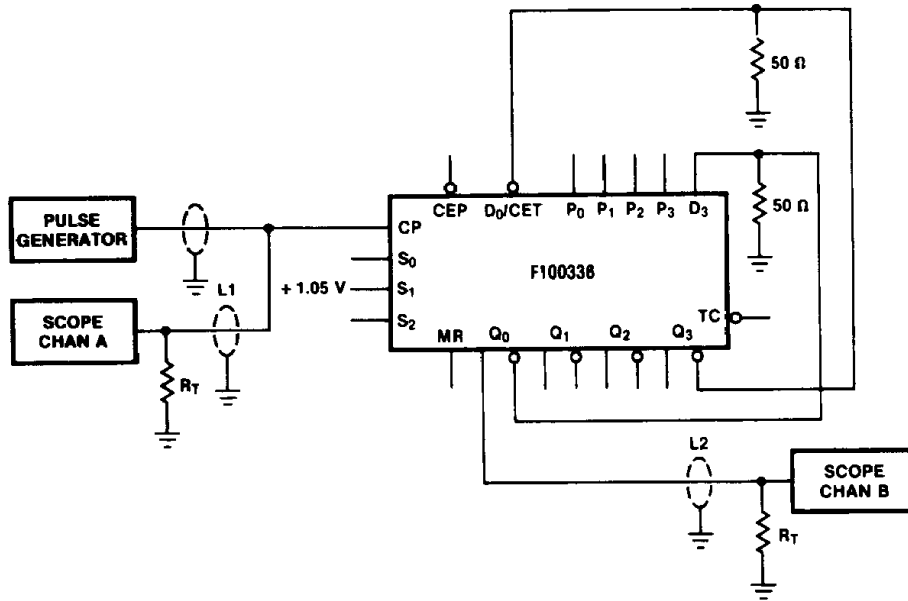

FIGURE 2. Shift Frequency Test Circuit (Shift Left)

TL/F/10584-7

**Notes:**

- For shift right mode,  $+1.05V$  is applied at  $S_0$ .
- The feedback path from output to input should be as short as possible.

# Switching Waveforms

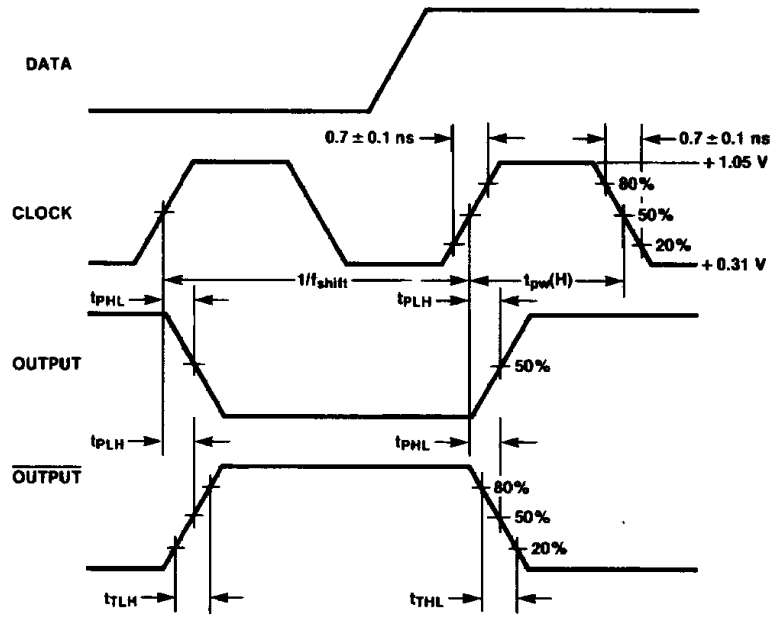

FIGURE 3. Propagation Delay (Clock) and Transition Times

TL/F/10584-8

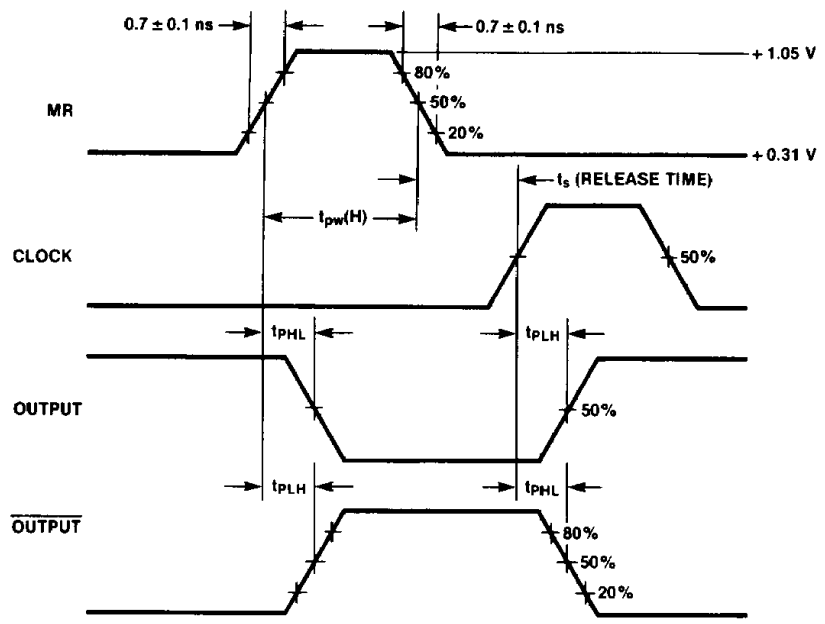

FIGURE 4. Propagation Delay (Reset)

TL/F/10584-9

Switching Waveforms (Continued)

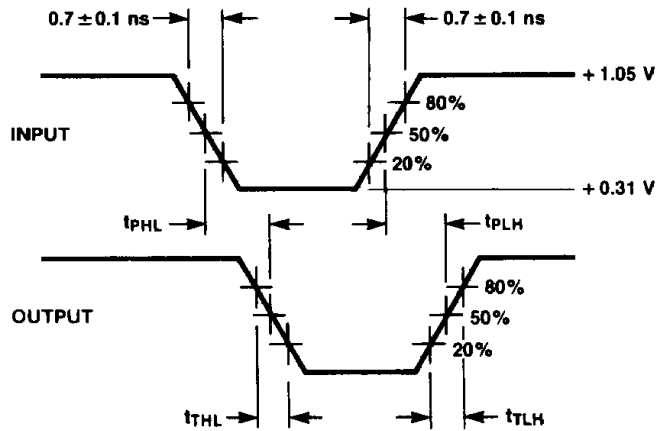
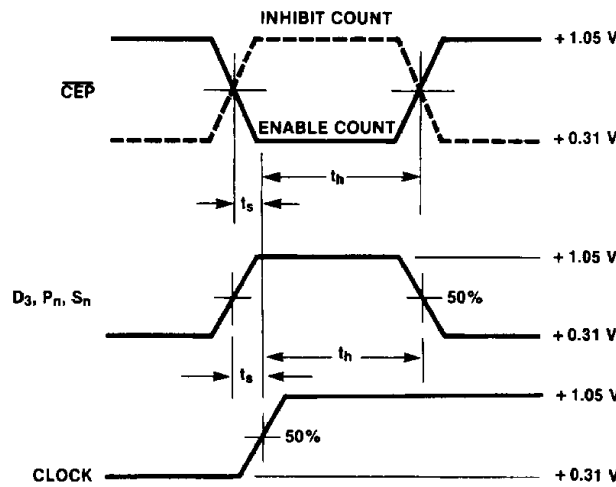

FIGURE 5. Propagation Delay (Serial Data, Selects)

TL/F/10584-10



TL/F/10584-11

Notes:

$t_s$  is the minimum time before the transition of the clock that information must be present at the data input.  
 $t_h$  is the minimum time after the transition of the clock that information must remain unchanged at the data input.

FIGURE 6. Setup and Hold Time

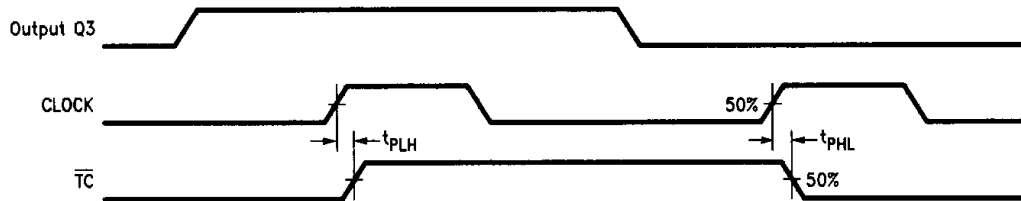

TL/F/10584-15

Note: Shift Right Mode;  $S_0 = H, S_1 = H, S_2 = L$ .

FIGURE 7. Propagation Delay, Clock to Terminal Count (Shift Right Mode)

### Switching Waveforms (Continued)

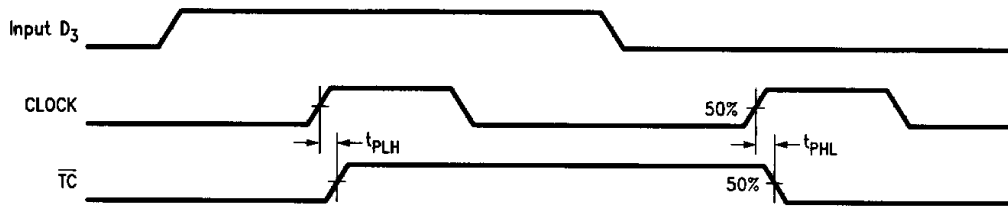

Note: Shift Left Mode;  $S_0 = L, S_1 = H, S_2 = L$ .

TL/F/10584-16

**FIGURE 8. Propagation Delay, Clock to Terminal Count (Shift Left Mode)**

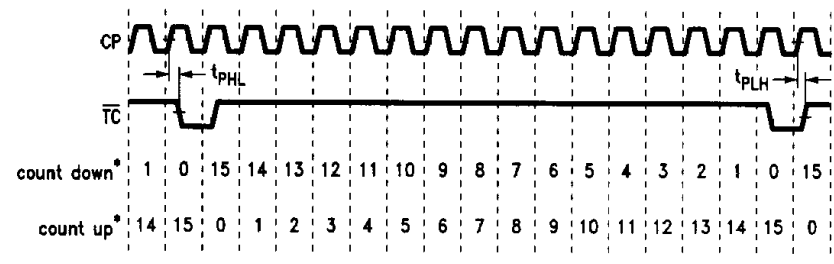

TL/F/10584-17

**Note:**

\*Decimal representation of binary outputs.  
 Count Up:  $S_0 = L, S_1 = H, S_2 = H$ ; Count Down:  $S_0 = L, S_1 = L, S_2 = H$ .  
 Measurement taken at 50% point of waveform.

**FIGURE 9. Propagation Delay, Clock to Terminal Count (Count Up and Count Down Modes)**

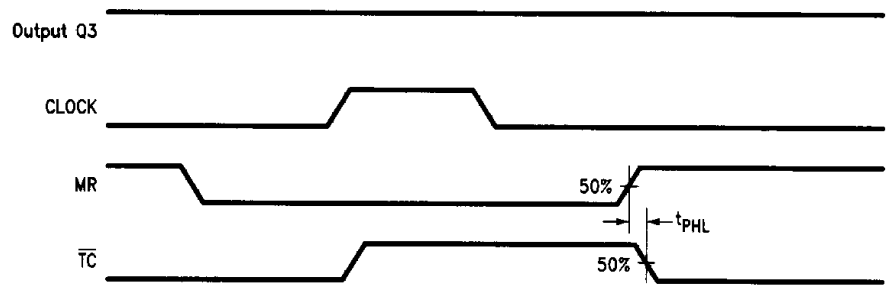

Note: Shift Right Mode;  $S_0 = H, S_1 = H, S_2 = L$ .

TL/F/10584-18

**FIGURE 10. Propagation Delay, Master Reset to Terminal Count (Shift Right Mode)**

**Switching Waveforms (Continued)**

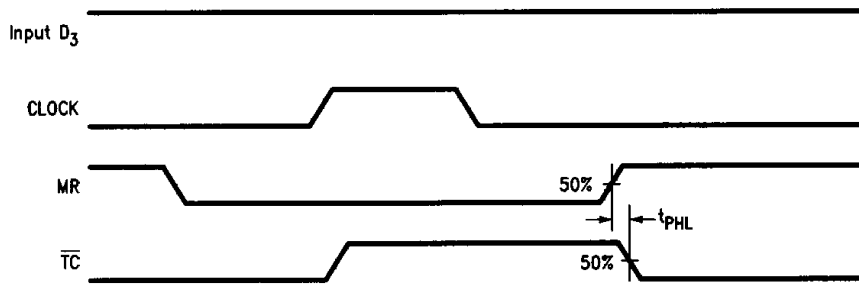

TL/F/10584-19

Note: Shift Left Mode;  $S_0 = L, S_1 = H, S_2 = L$ .

**FIGURE 11. Propagation Delay, Master Reset to Terminal Count (Shift Left Mode)**

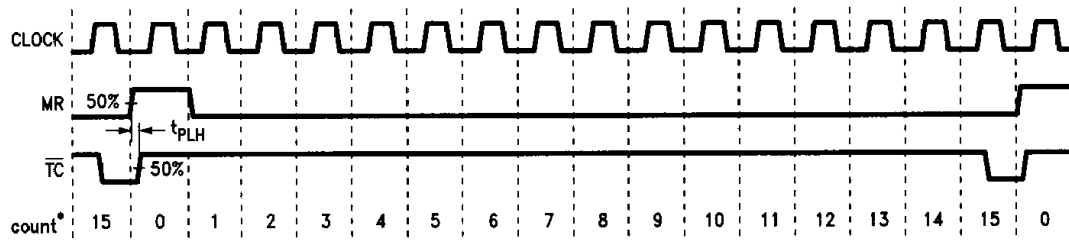

TL/F/10584-20

Note:

\*Decimal representation of binary outputs. Count Up Mode:  $S_0 = L, S_1 = H, S_2 = H$ .

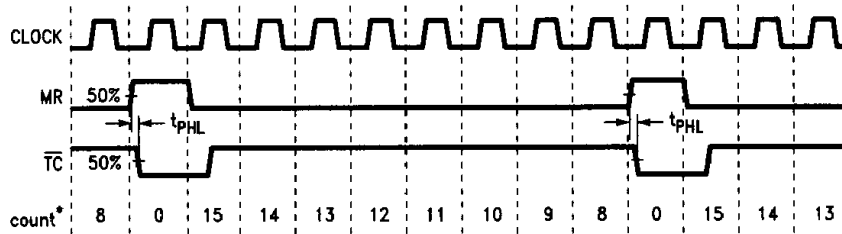

TL/F/10584-21

Note:

\*Decimal representation of binary outputs. Count Down Mode:  $S_0 = L, S_1 = L, S_2 = H$ .

**FIGURE 12. Propagation Delay, Master Reset to Terminal Count (Count Up and Count Down Modes)**

# Applications

## 3-Stage Divider, Preset Count Down Mode

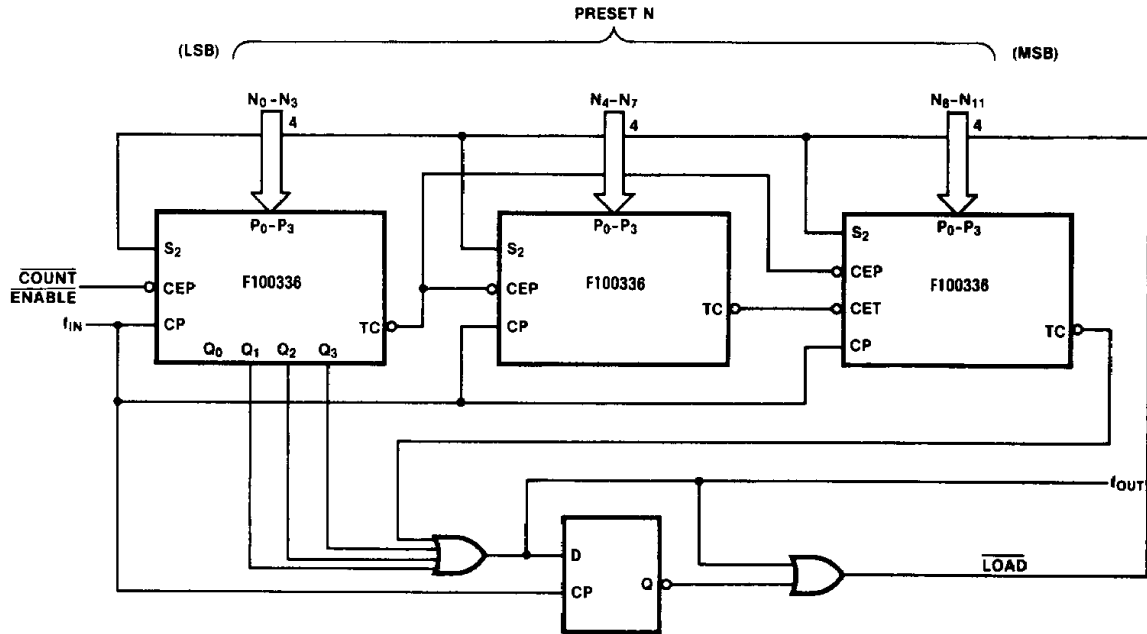

Note: If  $S_0 = S_1 = S_2 = \text{LOW}$ , then  $T_C = \text{LOW}$

TL/F/10584-12

### Slow Expansion Scheme

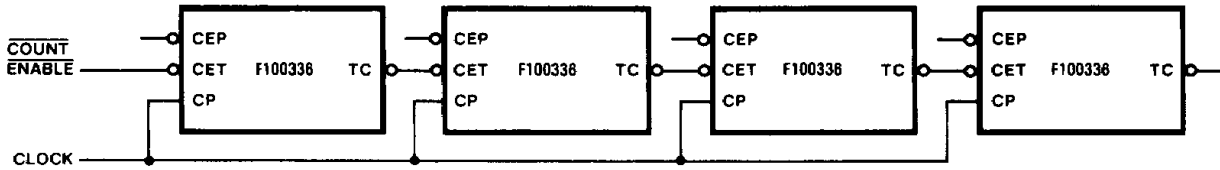

TL/F/10584-13

### Fast Expansion Scheme

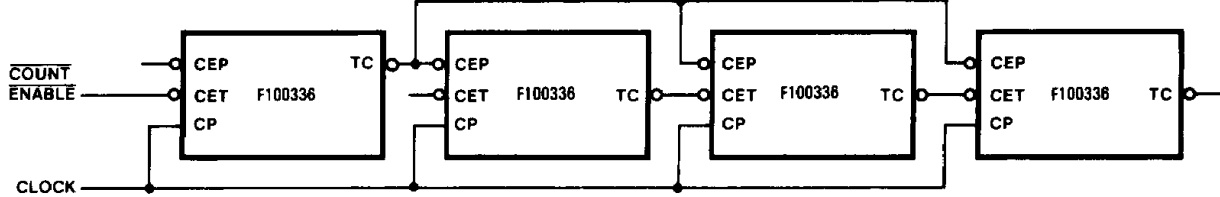

TL/F/10584-14