



F100360

Low Power Dual Parity Checker/Generator

General Description

The F100360 is a dual parity checker/generator. Each half has nine inputs; the output is HIGH when an even number of inputs are HIGH. One of the nine inputs (I_a or I_b) has the shorter through-put delay and is therefore preferred as the expansion input for generating parity for 16 or more bits. The F100360 also has a Compare (\bar{C}) output which allows the circuit to compare two 8-bit words. The \bar{C} output is LOW when the two words match, bit for bit. All inputs have 50 k Ω pulldown resistors.

Features

- Lower power than F100160
- 2000V ESD protection
- Pin/function compatible with F100160
- Voltage compensated operating range = -4.2V to -5.7V
- Min to Max propagation delay 35% tighter than F100160

Ordering Code: See Section 8

Logic Symbol

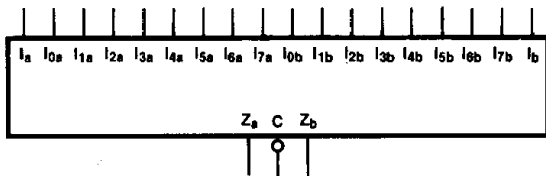

Pin Names	Description
I_a, I_b, I_{na}, I_{nb}	Data Inputs
Z_a, Z_b	Parity Odd Outputs
C	Compare Output

TL/F/10611-1

Connection Diagrams

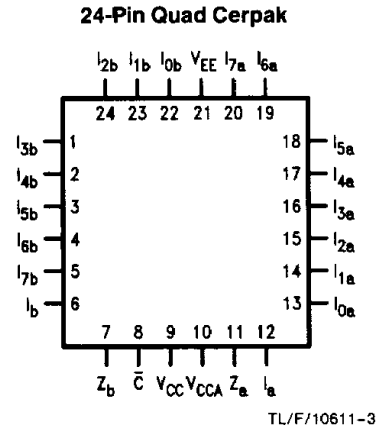
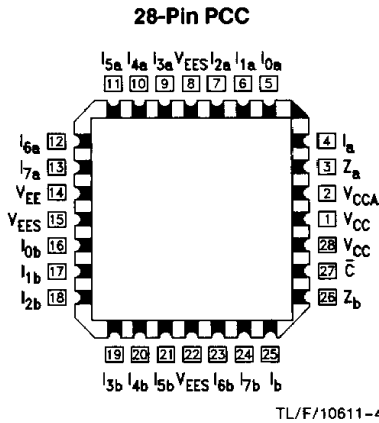
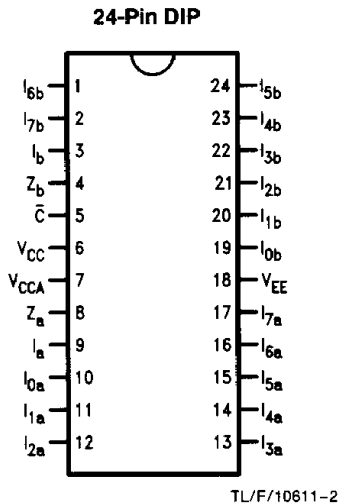

Logic Diagram

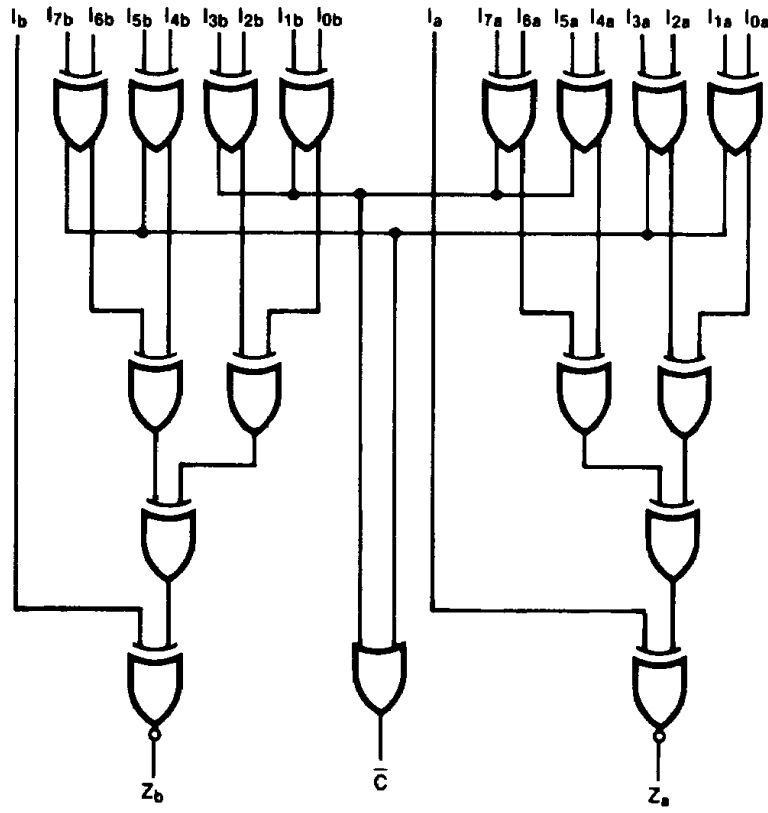

TL/F/10611-5

Truth Table (Each Half)

Sum of HIGH Inputs	Output Z
Even	HIGH
Odd	LOW

Comparator Function

$$\bar{C} = (I_{0a} \oplus I_{1a}) + (I_{2a} \oplus I_{3a}) + (I_{4a} \oplus I_{5a}) + (I_{6a} \oplus I_{7a}) + (I_{0b} \oplus I_{1b}) + (I_{2b} \oplus I_{3b}) + (I_{4b} \oplus I_{5b}) + (I_{6b} \oplus I_{7b})$$

Absolute Maximum Ratings

Above which the useful life may be impaired (Note 1)

If Military/Aerospace specified devices are required, please contact the National Semiconductor Sales Office/Distributors for availability and specifications.

Storage Temperature (T_{STG})	-65°C to +150°C
Maximum Junction Temperature (T_J)	
Ceramic	+175°C
Plastic	+150°C
V_{EE} Pin Potential to Ground Pin	-7.0V to +0.5V
Input Voltage (DC)	V_{EE} to +0.5V
Output Current (DC Output HIGH)	-50 mA
ESD (Note 2)	≥2000V

Recommended Operating Conditions

Case Temperature (T_C)	
Commercial	0°C to +85°C
Military	-55°C to +125°C
Supply Voltage (V_{EE})	
Commercial	-5.7V to -4.2V
Military	-5.7V to -4.2V

Commercial Version

DC Electrical Characteristics

$V_{EE} = -4.2V$ to $-5.7V$, $V_{CC} = V_{CCA} = GND$, $T_C = 0°C$ to $+85°C$ (Note 3)

Symbol	Parameter	Min	Typ	Max	Units	Conditions	
V_{OH}	Output HIGH Voltage	-1025	-955	-870	mV	$V_{IN} = V_{IH} (Max)$ or $V_{IL} (Min)$	Loading with 50Ω to -2.0V
V_{OL}	Output LOW Voltage	-1830	-1705	-1620	mV		
V_{OHC}	Output HIGH Voltage	-1035			mV	$V_{IN} = V_{IH} (Min)$ or $V_{IL} (Max)$	Loading with 50Ω to -2.0V
V_{OLC}	Output LOW Voltage			-1610	mV		
V_{IH}	Input HIGH Voltage	-1165		-870	mV	Guaranteed HIGH Signal for All Inputs	
V_{IL}	Input LOW Voltage	-1830		-1475	mV	Guaranteed LOW Signal for All Inputs	
I_{IL}	Input LOW Current	0.50			μA	$V_{IN} = V_{IL} (Min)$	
I_{IH}	Input HIGH Current I_a, I_b I_{na}, I_{nb}			340 240	μA	$V_{IN} = V_{IH} (Max)$	
I_{EE}	Power Supply Current	-100		-50	mA	Inputs Open	

Note 1: Absolute maximum ratings are those values beyond which the device may be damaged or have its useful life impaired. Functional operation under these conditions is not implied.

Note 2: ESD testing conforms to MIL-STD-883, Method 3015.

Note 3: The specified limits represent the "worst case" value for the parameter. Since these values normally occur at the temperature extremes, additional noise immunity and guardbanding can be achieved by decreasing the allowable system operating ranges. Conditions for testing shown in the tables are chosen to guarantee operation under "worst case" conditions.

Commercial Version (Continued)**Ceramic Dual-In-Line Package AC Electrical Characteristics** $V_{EE} = -4.2V$ to $-5.7V$, $V_{CC} = V_{CCA} = GND$

Symbol	Parameter	$T_C = 0^\circ C$		$T_C = +25^\circ C$		$T_C = +85^\circ C$		Units	Conditions
		Min	Max	Min	Max	Min	Max		
t_{PLH} t_{PHL}	Propagation Delay I_{na}, I_{nb} to Z_a, Z_b	1.10	2.75	1.10	2.75	1.10	2.75	ns	Figures 1 & 2
t_{PLH} t_{PHL}	Propagation Delay I_{na}, I_{nb} to \bar{C}	1.10	2.80	1.10	2.80	1.10	2.80	ns	
t_{PLH} t_{PHL}	Propagation Delay I_a, I_b to Z_a, Z_b	0.50	1.20	0.60	1.30	0.60	1.30	ns	
t_{TLH} t_{THL}	Transition Time 20% to 80%, 80% to 20%	0.35	1.10	0.35	1.10	0.35	1.10	ns	

PCC and Cerpak AC Electrical Characteristics $V_{EE} = -4.2V$ to $-5.7V$, $V_{CC} = V_{CCA} = GND$

Symbol	Parameter	$T_C = 0^\circ C$		$T_C = +25^\circ C$		$T_C = +85^\circ C$		Units	Conditions
		Min	Max	Min	Max	Min	Max		
t_{PLH} t_{PHL}	Propagation Delay I_{na}, I_{nb} to Z_a, Z_b	1.10	2.75	1.10	2.75	1.10	2.75	ns	Figures 1 & 2
t_{PLH} t_{PHL}	Propagation Delay I_{na}, I_{nb} to \bar{C}	1.10	2.80	1.10	2.80	1.10	2.80	ns	
t_{PLH} t_{PHL}	Propagation Delay I_a, I_b to Z_a, Z_b	0.50	1.20	0.60	1.30	0.60	1.30	ns	
t_{TLH} t_{THL}	Transition Time 20% to 80%, 80% to 20%	0.35	1.10	0.35	1.10	0.35	1.10	ns	
$t_{s,G-G}$	Skew, Gate to Gate		TBD		TBD		TBD	ps	PCC only Note 1

Note 1: Gate to gate skew is defined as the difference in propagation delays between each of the outputs.

Military Version — Preliminary

DC Electrical Characteristics

$V_{EE} = -4.2V$ to $-5.7V$, $V_{CC} = V_{CCA} = GND$, $T_C = -55^\circ C$ to $+125^\circ C$

Symbol	Parameter	Min	Max	Units	T_C	Conditions	Notes	
V_{OH}	Output HIGH Voltage	-1025	-870	mV	$0^\circ C$ to $+125^\circ C$	$V_{IN} = V_{IH} (Max)$ or $V_{IL} (Min)$	Loading with 50Ω to $-2.0V$	1, 2, 3
		-1085	-870	mV	$-55^\circ C$			
V_{OL}	Output LOW Voltage	-1830	-1620	mV	$0^\circ C$ to $+125^\circ C$			
		-1830	-1555	mV	$-55^\circ C$			
V_{OHC}	Output HIGH Voltage	-1035		mV	$0^\circ C$ to $+125^\circ C$	$V_{IN} = V_{IH} (Min)$ or $V_{IL} (Max)$	Loading with 50Ω to $-2.0V$	1, 2, 3
		-1085		mV	$-55^\circ C$			
V_{OLC}	Output LOW Voltage		-1610	mV	$0^\circ C$ to $+125^\circ C$			
			-1555	mV	$-55^\circ C$			
V_{IH}	Input HIGH Voltage	-1165	-870	mV	$-55^\circ C$ to $+125^\circ C$	Guaranteed HIGH Signal for All Inputs	1, 2, 3, 4	
V_{IL}	Input LOW Voltage	-1830	-1475	mV	$-55^\circ C$ to $+125^\circ C$	Guaranteed LOW Signal for All Inputs	1, 2, 3, 4	
I_{IL}	Input LOW Current	0.50		μA	$-55^\circ C$ to $+125^\circ C$	$V_{EE} = -4.2V$ $V_{IN} = V_{IL} (Min)$	1, 2, 3	
I_{IH}	Input HIGH Current $I_{a, Ib}$ $I_{na, Inb}$		340 240	μA	$0^\circ C$ to $+125^\circ C$	$V_{EE} = -5.7V$ $V_{IN} = V_{IH} (Max)$	1, 2, 3	
			490 340	μA	$-55^\circ C$			
I_{EE}	Power Supply Current	-110	-50	mA	$-55^\circ C$ to $+125^\circ C$	Inputs Open	1, 2, 3	

Note 1: F100K 300 Series cold temperature testing is performed by temperature soaking (to guarantee junction temperature equals $-55^\circ C$), then testing immediately without allowing for the junction temperature to stabilize due to heat dissipation after power-up. This provides "cold start" specs which can be considered a worst case condition at cold temperatures.

Note 2: Screen tested 100% on each device at $-55^\circ C$, $+25^\circ C$, and $+125^\circ C$, Subgroups 1, 2, 3, 7, and 8.

Note 3: Sample tested (Method 5005, Table I) on each manufactured lot at $-55^\circ C$, $+25^\circ C$, and $+125^\circ C$, Subgroups A1, 2, 3, 7, and 8.

Note 4: Guaranteed by applying specified input condition and testing V_{OH}/V_{OL} .

Military Version — Preliminary (Continued)**Ceramic Dual-In-Line Package AC Electrical Characteristics** $V_{EE} = -4.2V$ to $-5.7V$, $V_{CC} = V_{CCA} = GND$

Symbol	Parameter	$T_C = -55^\circ C$		$T_C = +25^\circ C$		$T_C = +125^\circ C$		Units	Conditions	Notes
		Min	Max	Min	Max	Min	Max			
t_{PLH} t_{PHL}	Propagation Delay I_{na}, I_{nb} to Z_a, Z_b	1.00	2.95	1.00	2.95	1.00	2.95	ns	Figures 1 & 2	1, 2, 3
t_{PLH} t_{PHL}	Propagation Delay I_{na}, I_{nb} to \bar{C}	1.00	3.00	1.00	3.00	1.00	3.00	ns		
t_{PLH} t_{PHL}	Propagation Delay I_a, I_b to Z_a, Z_b	0.40	1.40	0.50	1.50	0.50	1.50	ns		
t_{TLH} t_{THL}	Transition Time 20% to 80%, 80% to 20%	0.35	1.10	0.35	1.10	0.35	1.10	ns		4

Cerpak AC Electrical Characteristics $V_{EE} = -4.2V$ to $-5.7V$, $V_{CC} = V_{CCA} = GND$

Symbol	Parameter	$T_C = -55^\circ C$		$T_C = +25^\circ C$		$T_C = +125^\circ C$		Units	Conditions	Notes
		Min	Max	Min	Max	Min	Max			
t_{PLH} t_{PHL}	Propagation Delay I_{na}, I_{nb} to Z_a, Z_b	1.00	2.95	1.00	2.95	1.00	2.95	ns	Figures 1 & 2	1, 2, 3
t_{PLH} t_{PHL}	Propagation Delay I_{na}, I_{nb} to \bar{C}	1.00	3.00	1.00	3.00	1.00	3.00	ns		
t_{PLH} t_{PHL}	Propagation Delay I_a, I_b to Z_a, Z_b	0.40	1.40	0.50	1.50	0.50	1.50	ns		
t_{TLH} t_{THL}	Transition Time 20% to 80%, 80% to 20%	0.35	1.10	0.35	1.10	0.35	1.10	ns		4

Note 1: F100K 300 Series cold temperature testing is performed by temperature soaking (to guarantee junction temperature equals $-55^\circ C$), then testing immediately after power-up. This provides "cold start" specs which can be considered a worst case condition at cold temperatures.

Note 2: Screen tested 100% on each device at $+25^\circ C$ temperature only, Subgroup A9.

Note 3: Sample tested (Method 5005, Table I) on each mfg. lot at $+25^\circ C$, Subgroup A9, and at $+125^\circ C$ and $-55^\circ C$ temperatures, Subgroups A10 and A11.

Note 4: Not tested at $+25^\circ C$, $+125^\circ C$, and $-55^\circ C$ temperature (design characterization data).

Test Circuitry

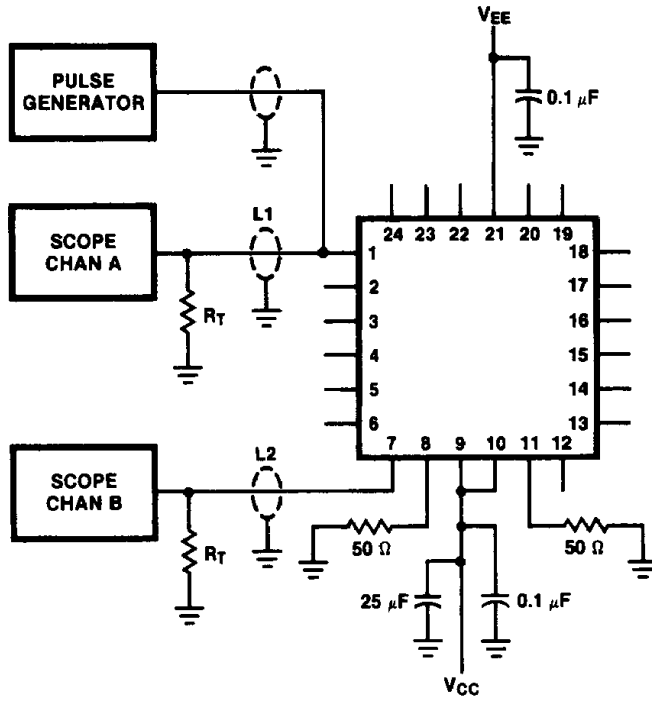

FIGURE 1. AC Test Circuit

TL/F/10611-6

Notes:

- V_{CC}, V_{CCA} = +2V, V_{EE} = -2.5V
- L1 and L2 = equal length 50Ω impedance lines
- R_T = 50Ω terminator internal to scope
- Decoupling 0.1 μF from GND to V_{CC} and V_{EE}
- All unused outputs are loaded with 50Ω to GND
- C_L = Fixture and stray capacitance ≤ 3 pF
- Pin numbers shown are for flatpak; for DIP see logic symbol

Switching Waveforms

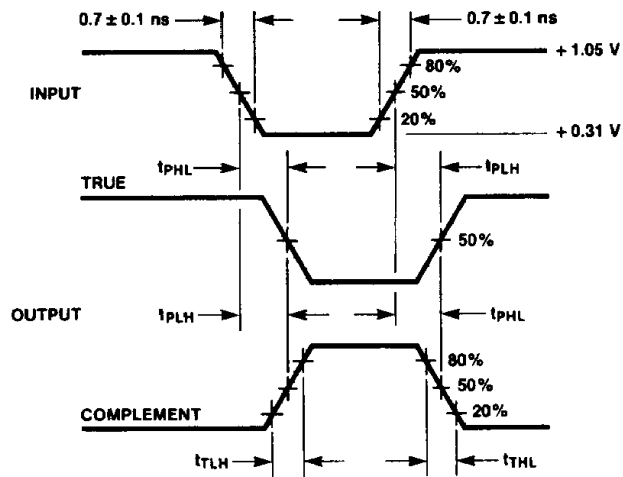

FIGURE 2. Propagation Delay and Transition Times

TL/F/10611-7