

LH7070 Series Precision BCD Buffered Reference LH7071 Series Precision Binary Buffered Reference

General Description

The LH7070 and LH7071 are precision, three terminal, voltage references consisting of a temperature compensated zener diode driven by a current regulator and a buffer amplifier. The devices provide an accurate reference that is virtually independent of input voltage, load current, temperature and time. The LH7070 has a 10.000V nominal output to provide equal step sizes in BCD applications. The LH7071 has a 10.240V nominal output to provide equal step sizes in binary applications.

The output voltage is established by trimming ultrastable, low temperature drift, thin film resistors under actual operating circuit conditions. The devices are short-circuit proof in both the current sourcing and sinking directions.

The LH7070 and LH7071 series combine excellent long term stability, ease of application, and low cost, making them ideal choices as reference voltages in precision D to A and A to D systems.

Features

- Accurate output voltage
 - LH7070 10V \pm 0.03%
 - LH7071 10.24V \pm 0.03%
- Single supply operation 11.4V to 40V
- Low output impedance 0.2 Ω
- Excellent line regulation 0.2 mV/V
- Low zener noise 20 μ Vp-p
- Short circuit proof
- Low standby current 3 mA

Equivalent Schematic

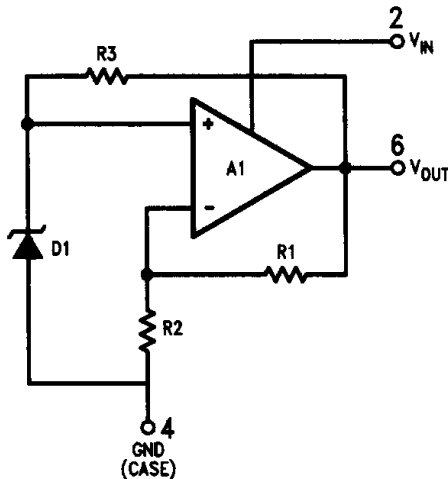

TL/K/10032-1

Connection Diagram

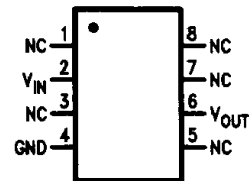

Top View

TL/K/10032-2

Order Number LH7070CN or LH7071CN
See NS Package Number N08E

Absolute Maximum Ratings

If Military/Aerospace specified devices are required, please contact the National Semiconductor Sales Office/Distributors for availability and specifications.

Supply Voltage	40V
Power Dissipation (See Curve)	800 mW
Short Circuit Duration	Continuous

Output Current	± 20 mA
Operating Temperature Range	-25°C to +85°C
Storage Temperature Range	-65°C to +150°C
Lead Temperature (Soldering, 10 Sec.)	300°C

Electrical Characteristics (Note 1)

Parameter	Conditions	Min	Typ	Max	Units
Output Voltage	$T_A = 25^\circ\text{C}$ LH7070 LH7071		10.000		V
			10.240		V
Output Accuracy	$T_A = 25^\circ\text{C}$ LH7070, LH7071		±0.03	±0.1	%
Output Accuracy	$T_A = -25^\circ\text{C to } +85^\circ\text{C}$ (Note 3)			±0.3	%
Output Voltage Change with Temperature	(Notes 2, 3)			±0.14	%
Line Regulation	$13\text{V} \leq V_{\text{IN}} \leq 33\text{V}$, $T_A = 25^\circ\text{C}$		0.02	0.1	%
Input Voltage Range	$R_L = 50\text{ k}\Omega$	11.4		40	V
Load Regulation	$0\text{ mA} \leq I_{\text{OUT}} \leq 5\text{ mA}$		0.01	0.03	%
Quiescent Current	$13\text{V} \leq V_{\text{IN}} \leq 33\text{V}$, $I_{\text{OUT}} = 0\text{ mA}$	1	2	3	mA
Change in Quiescent Current	$\Delta V_{\text{IN}} = 20\text{V}$ from 13V to 33V		0.75	1.5	mA
Output Noise Voltage	BW = 0.1 Hz to 10 Hz, $T_A = 25^\circ\text{C}$		20		$\mu\text{V}_{\text{p-p}}$
Ripple Rejection	$f = 120\text{ Hz}$		0.01		$\%/V_{\text{p-p}}$
Output Resistance			0.2	0.6	Ω
Long Term Stability	$T_A = 25^\circ\text{C}$ (Note 3)			±0.2	%/yr.

Note 1: Unless otherwise specified, these specifications apply for $V_{\text{IN}} = 15.0\text{V}$, $R_L = 10\text{ k}\Omega$, and over the temperature range of $-25^\circ\text{C} \leq T_A \leq +85^\circ\text{C}$.

Note 2: This specification is the difference in output voltage measured at $T_A = 85^\circ\text{C}$ and $T_A = 25^\circ\text{C}$ or $T_A = 25^\circ\text{C}$ and $T_A = -25^\circ\text{C}$ with readings taken after test chamber and device-under-test stabilization at temperature using a suitable precision voltmeter.

Note 3: This parameter is guaranteed by design and not tested.

Typical Performance Characteristics

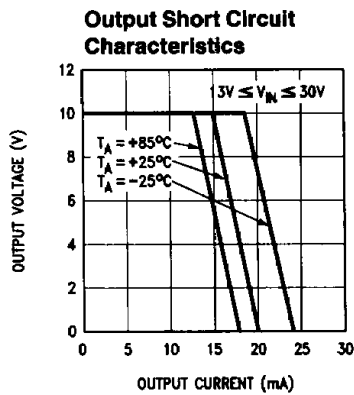
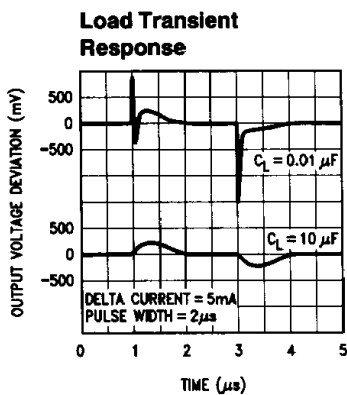
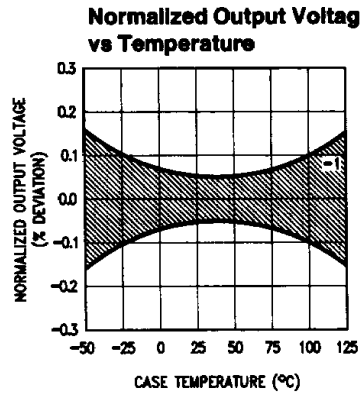
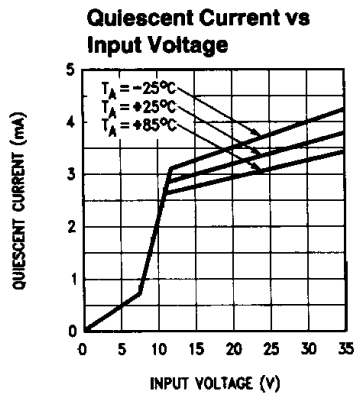
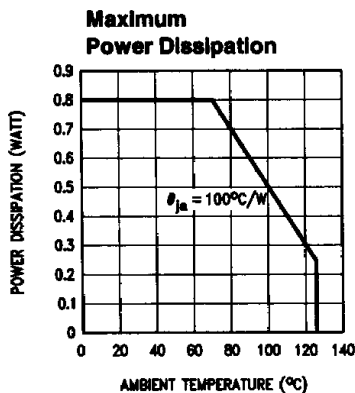

TL/K/10032-5

Noise Voltage

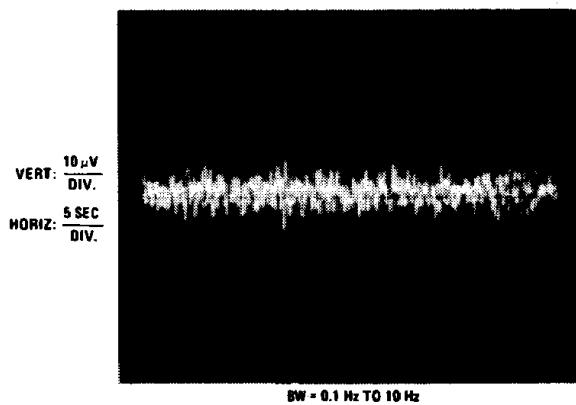

BW = 0.1 Hz TO 10 Hz

TL/K/10032-6

Typical Applications

Statistical Voltage Standard

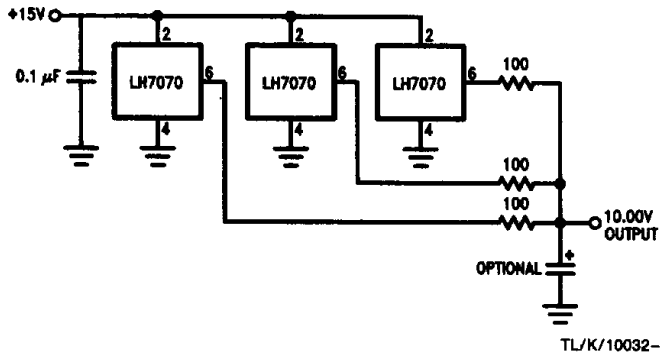

TL/K/10032-3

***Output Voltage Fine Adjustment**

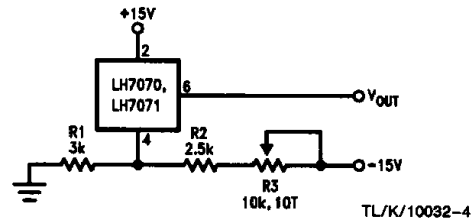

TL/K/10032-4

***Note:** The output of the LH7070 and LH7071 may be adjusted to a precise voltage by using the above circuit since the supply current of the device is relatively small and constant with temperature and input voltage. For the circuit shown, supply sensitivities are degraded slightly to 0.01%/V change in V_{OUT} for changes in V_{IN} and V^- .

An additional temperature drift of 0.0001%/°C is added due to the variation of supply current with temperature of the LH7070 and LH7071. Sensitivity to the value of R1, R2 and R3 is less than 0.001%/.

Expanded Scale AC Voltmeter

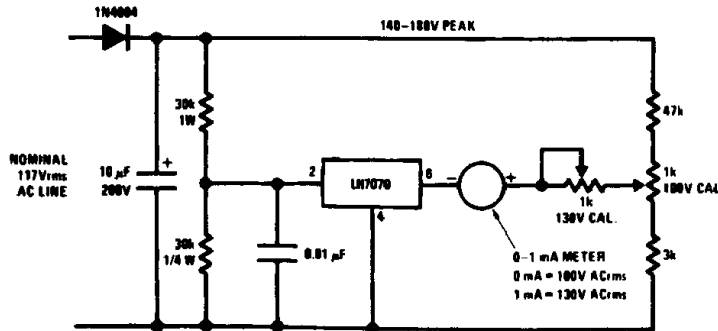

TL/K/10032-7

Dual Output Bench Power Supply

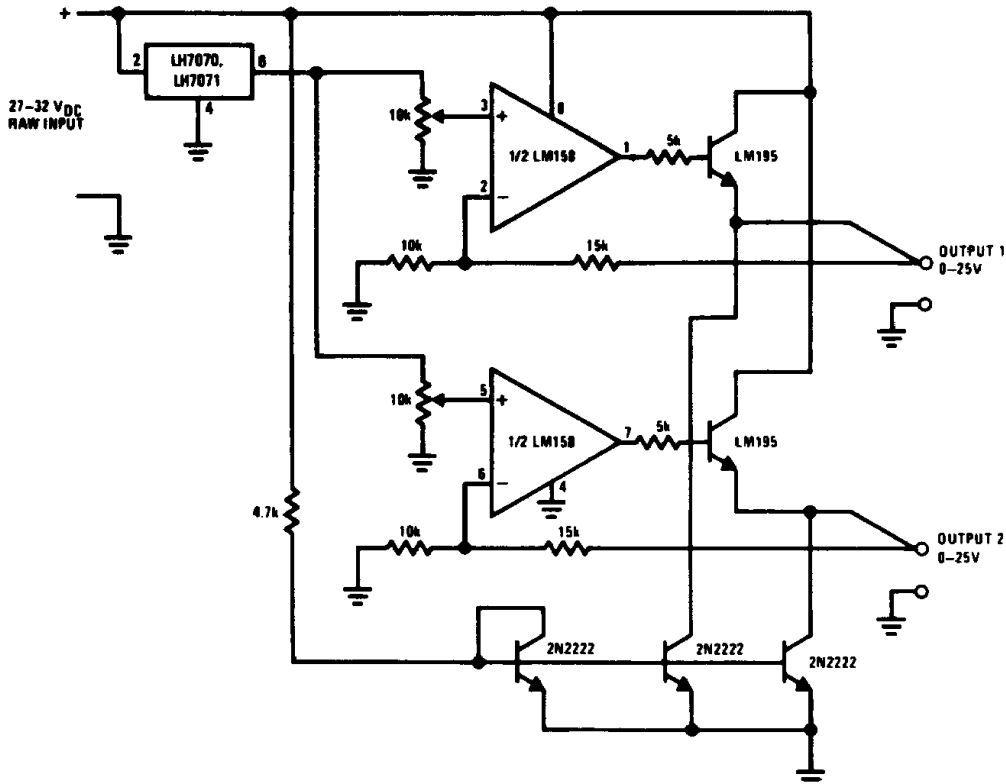

TL/K/10032-8

Typical Applications (Continued)

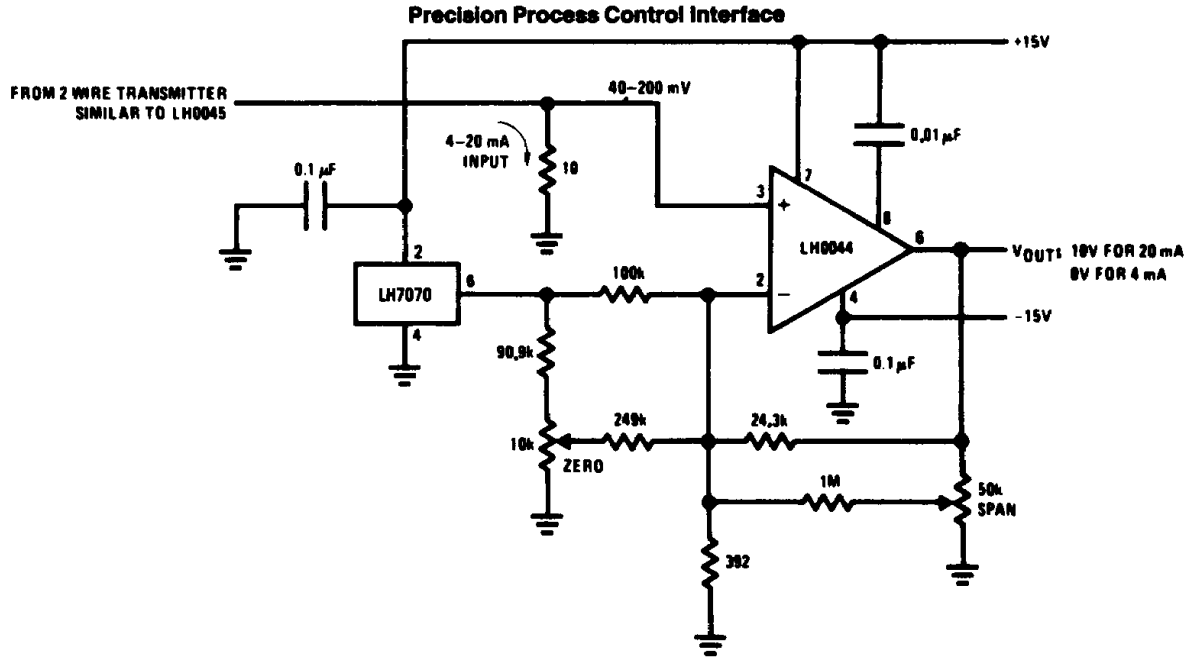

Negative 10V Reference

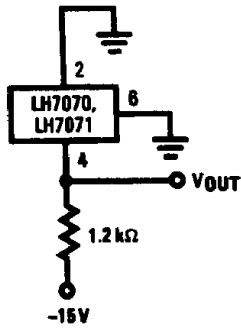

Current Boost for Low Input Voltages

