

LM1253A

Monolithic Triple 180 MHz I²C CRT Pre-amp With Integrated Analog On Screen Display (OSD) Generator

General Description

The LM1253A pre-amp is an integrated high voltage triple CRT pre-amp and Analog On Screen Display (OSD) generator. The IC is I²C controlled, and allows control of all the parameters necessary to setup and adjust the brightness and contrast in the CRT display. In addition, it provides a programmable period vertical blanking pulse which is used to blank the G1.

The LM1253A pre-amp is designed to work in cooperation with the LM2453 driver, and provides a multiplexed video signal (VideoPlex) interface to enable the DC clamp levels at the cathode to be varied in order to set up the CRT bias and to allow individual adjustment for brightness.

The Analog OSD has a selectable palette allowing a wide selection of colors. The preset level of the OSD can be controlled by I²C to suit different CRT displays. The OSD signal is internally mixed with the video signal, before the gain section, and thus gives excellent white tracking of the OSD with the white color point setting of the video.

The Brightness settings are also mixed into the video signal before the gain matching controls and consequently give excellent white color point tracking with variations in the Brightness control. An active horizontal blanking signal is added to the video at the output, giving excellent smear performance, and preventing video content dependent DC bias offsets as a result of high frequency over shoot.

The OSD horizontal sync and blanking signal is derived from a positive going flyback pulse. The digital section provides easy interfacing of this signal with the deflection circuits.

The vertical blanking signal is taken from the vertical sync signal, and the blanking duration is programmable. This system is highly integrated and requires a minimal number of external components.

Black level clamping of the signal is carried out directly on the AC coupled input signal into the high impedance pre-amplifier input, thus eliminating the need for additional black level clamp capacitors.

The outputs are referenced to a DC level produced by the LM1253A Pre-amp, and so are guaranteed to provide stable DC operating levels within the system without the need for additional external feedback components.

The IC is packaged in an industry standard wide body 28-lead DIL molded plastic package.

Features

- 190 two-color ROM based Character Fonts
- 64 four-color ROM based Character Fonts
- Supports a programmable page size with up to 512 characters and line definition codes
- Support for 2 Display Windows (size of each window is configurable)
- Programmable start position for each Display Window
- Programmable Resolutions: from 512 to 960 pixels per line in 64 pixel increments
- Programmable Character Height, with automatic height control with mode change
- Programmable Row Spacing between each display character row
- Maximum Pixel clock of 92.2 MHz
- I²C compatible interface to controlling micro-controller
- Button boxes
- 180 MHz preamplifier with full video signal parametric control
- VideoPlex™ interface to the LM2453 driver
- OSD mixing with 64 out of 512 color mask programmable selection

Intended Applications

- 1280 x 1024 Displays up to 75 Hz requiring OSD capability

Block and Connection Diagrams

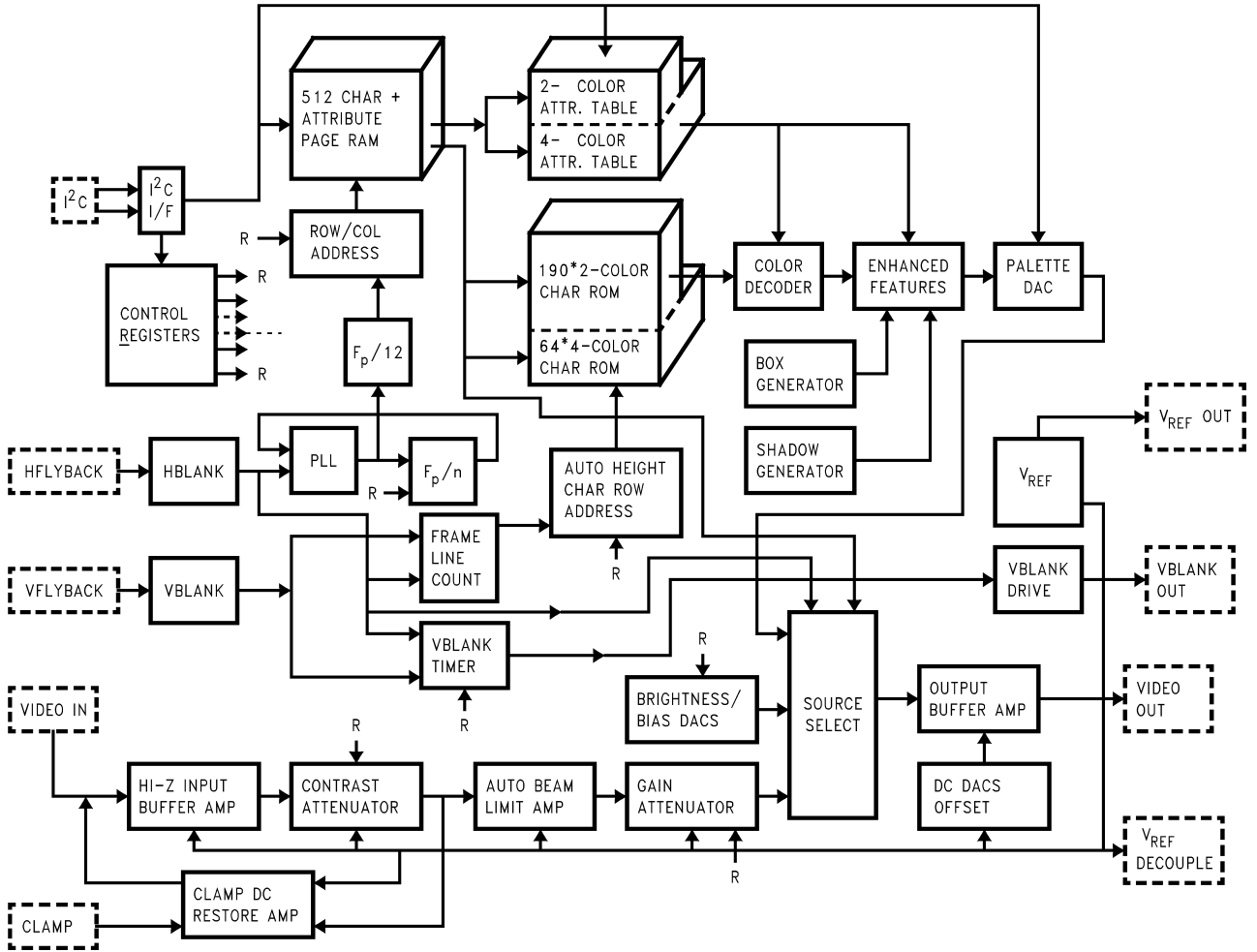
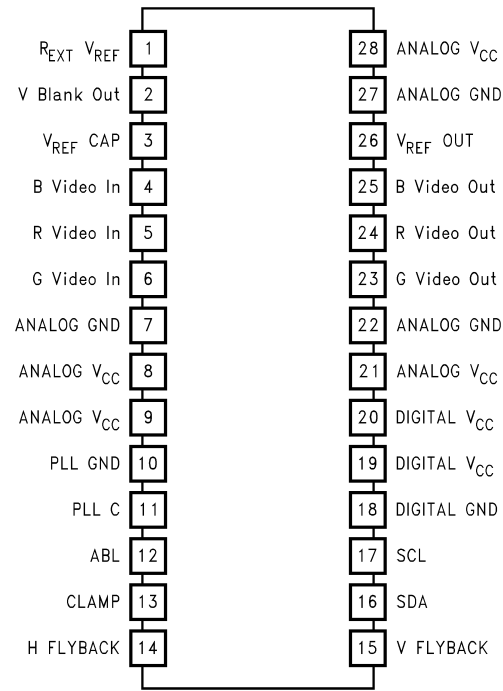

FIGURE 1. Block Diagram

DS101265-1

Block and Connection Diagrams (Continued)

28-Lead (0.600" wide) Molded Dual-In-Line Package



DS101265-2

Order Number LM1253AN
 See NS Package Number N28B
FIGURE 2. Connection Diagram

Table of Contents

Block and Connection Diagrams	3
Absolute Maximum Ratings	5
Operating Ratings	5
Electrical Characteristics	5
Test Circuit	7
Test Settings	8
Pin Descriptions	8
Input/Output Schematics	13
National VideoPlex Video System	15
ESD and Arc-Over Protection	16
Pre-Amp Functional Description	17
Horizontal Phase Locked Loop	19
Fault Operation	19
Power Save Mode	19
Schematics	20
PCB Layout	22
OSD Generator Operation	23
Micro-Controller Interface	27
LM1253A Address Map	29
Pre-Amp Interface Registers	30
Two-Color Attribute Table	31
Four-Color Attribute Table	31
Display Page RAM	32
Controller Register Definitions	40
Character Font	51

List of Tables

Table 1 Control Test Settings	7
Table 2 Registers Controlling the Output Video and Clamp Signal	18
Table 3 Character ROM Address Map	29
Table 4 Display Page RAM Address Map	29
Table 5 OSD Interface Registers	30
Table 6 Pre-Amp Interface Registers	31
Table 7 Two-Color Attribute Registers	31
Table 8 Four-Color Attribute Registers	31
Table 9 Example 1 I ² C Transmission	35
Table 10 Example 2 I ² C Transmissions	36
Table 11 Example 3 I ² C Transmissions	39
Table 12 PLL Setting (Register 843Eh)	46
Table 13 Attribute Tables to I ² C Address	48

Absolute Maximum Ratings (Notes 1, 3)

If Military/Aerospace specified devices are required, please contact the National Semiconductor Sales Office/Distributors for availability and specifications.

Supply Voltage, (V_{CC})	6V
Input Voltage, (V_{IN})	6V
Storage Temperature Range, (T_{STG})	-65°C to +150°C
T_{JMAX}	150°C

Lead Temperature (Soldering, <10 sec.)	300°C
ESD Tolerance, Human Body Model	3 kV
Machine Model	300V

Operating Ranges (Note 2)

Temperature Range	0°C to +70°C
V_{CC}	+4.75V to +5.25V

Active Video Signal Electrical Characteristics

(See Figure 3 for Test Circuit, and Table 1 for Control Test Settings Chart)

Unless otherwise noted: $V_{CC} = +5V$, $V_{IN} = 0.7V$, $C_L = 8$ pF, Video Signal Output = 1 V_{PP} , $T_A = 25^\circ C$, $V_{ABL} = V_{CC}$.

Symbol	Parameter	Conditions	LM1253A			Units
			Min	Typ	Max	
I_{CC1MAX}	Maximum Supply Current	Test Setting 1, No Output Load		245		mA
$V_{OUT\ BLK}$	Active Video Black Level Minimum Output Voltage	Test Setting 1, No AC Input Signal		V_{REF}		V_{DC}
LE	Linearity Error	Test Setting 3, (Note 4), Triangular Step Signal Input		1		%
$V_{OUT\ WHITE}$	Active Video White Level Max Output Voltage	Test Setting 3, AC Input Signal		2.7		V
t_r	Rise Time	Test Setting 3, (Note 5), 10% to 90%, AC Input Signal		3.0		ns
t_f	Fall Time	Test Setting 3, (Note 5), 90% to 10%, AC Input Signal		3.0		ns
OS_R	Rising Edge Overshoot	Test Setting 3, (Note 5), AC Input Signal		5		%
OS_F	Falling Edge Overshoot	Test Setting 3, (Note 5), AC Input Signal		5		%
$f(-3dB)$	Video Amplifier Bandwidth	Measured in AC2DC002 Demo Board. LM1253A set for 40 V_{PP} swing at LM2453 output		180		MHz
$A_{CONTRAST}$	Contrast Max-Min Adjustment Range	Test Setting 2, AC Input Signal		20		dB
A_{GAIN}	Gain Max-Min Adjustment Range	Test Setting 2, AC Input Signal		10		dB
A_{MAX}	Max Signal Voltage Gain	Test Setting 2, AC Input Signal		1.8		V/V
$V_{ABL\ TH}$	Auto Beam Limit Control Upper Limit	Test Setting 3, (Note 6), AC Input Signal		4.5		V
$V_{ABL\ RANGE}$	Auto Beam Limit Control Voltage Range	Test Setting 3, (Note 6), AC Input Signal		3		V
ΔA_{ABL}	Auto Beam Limit Control Range	Test Setting 3, (Note 6), AC Input Signal	-10			dB
$I_{ABL\ MAX}$	Auto Beam Limit Input Current Sink Capability	Test Setting 3, (Note 6), AC Input Signal			1	mA
C_{IP}	Input AC Coupling Capacitor	Test Setting 3		4.7		nF
V_{REF}	Typical V_{REF} Output Voltage		1.55	1.65	1.75	V
XT	Channel to Channel Crosstalk	10 MHz		40		dB

Brightness/Bias Signal Electrical Characteristics

(See Figure 3 for Test Circuit, and Table 1 for Control Test Settings Chart)

Unless otherwise noted: $V_{CC} = +5V$, $V_{IN} = 0.7V$, $C_L = 8\text{ pF}$, Video Signal Output = $1 V_{PP}$, $T_A = 25^\circ\text{C}$, $V_{ABL} = V_{CC}$.

Symbol	Parameter	Conditions	LM1253A			Units
			Min	Typ	Max	
$V_{BLANK\ MAX}$	Maximum Blanking Level	Test Setting 1		$V_{REF} - 0.90$		V
$V_{BLANK\ MIN}$	Minimum Blanking Level	Test Setting 4		V_{REF}		V
$t_{BLK\ r}$	Blanking Rise Time	Test Setting 1, 10% to 90%,		10		ns
$t_{BLK\ f}$	Blanking Fall Time	Test Setting 1, 90% to 10%,		10		ns
$OS_{BLK\ MAX}$	Maximum Rise or Fall Edge Overshoot	Test Setting 1, 10% to 90% or 90% to 10%, Settling Time Must be Less Than 50 ns		20		%

OSD Electrical Characteristics

(See Figure 3 for Test Circuit)

Unless otherwise noted: $V_{CC} = +5V$, $V_{IN} = 0.7V$, $C_L = 8\text{ pF}$, Video Signal Output = $1 V_{PP}$, $T_A = 25^\circ\text{C}$, $V_{ABL} = V_{CC}$.

Symbol	Parameter	Conditions	LM1253A			Units
			Min	Typ	Max	
$V_{OSDHIGH\ MAX}$	Maximum OSD Level with OSD Contrast 11	Palette Set at 111. OSD Contrast Level 11, Test Setting 3		$V_{REF} + 0.95$		V
$V_{OSDHIGH\ 10}$	Maximum OSD Level with OSD Contrast 10	Palette Set at 111. OSD Contrast Level 10, Test Setting 3		$V_{REF} + 0.77$		V
$V_{OSDHIGH\ 01}$	Maximum OSD Level with OSD Contrast 01	Palette Set at 111. OSD Contrast Level 01, Test Setting 3		$V_{REF} + 0.59$		V
$V_{OSDHIGH\ 00}$	Maximum OSD Level with OSD Contrast 00	Palette Set at 111. OSD Contrast Level 00, Test Setting 3		$V_{REF} + 0.41$		V

External Interface Signals Electrical Characteristics

(See Figure 3 for Test Circuit)

Unless otherwise noted: $V_{CC} = +5V$, $V_{IN} = 0.7V$, $C_L = 8\text{ pF}$, Video Signal Output = $1 V_{PP}$, $T_A = 25^\circ\text{C}$, $V_{ABL} = V_{CC}$.

Symbol	Parameter	Conditions	LM1253A			Units
			Min	Typ	Max	
I_{IN-MAX}	Maximum normal forward scan current at lowest horizontal frequency that input can withstand		-150			μA
$V_{HBLANK\ TRIG}$	Voltage on H Flyback (Pin 14) which will Trigger an HBLANK Signal	100V H Flyback Signal through a 100 k Ω Resistor		0.8		V
I_{IN+MAX}	Maximum flyback scan current at 125 kHz that input can withstand				1.5	mA
$t_{min\ hflb}$	Minimum Flyback Width		1			μs
t_H	Horizontal Period		20		125	kHz
$t_{PW\ CLAMP}$	Minimum Clamp Pulse Width		200			ns
$V_{CLAMP\ L\ MAX}$	Maximum Low Level Clamp Pulse Voltage				1	V
$V_{CLAMP\ H\ MIN}$	Minimum High Level Clamp Pulse Voltage		3			V
$V_{VBLANK\ HIGH}$	Minimum High Level of Vertical Blank Output	$V_{VREF\ BLANK} < 0.75V$	$V_{REF} + 1$			V
$V_{VBLANK\ LOW}$	Maximum Low Level of Vertical Blank Output	$I_{VBLANK\ OUT} = 100\ \mu\text{A}$			$V_{REF} - 1$	V

External Interface Signals Electrical Characteristics (Continued)

(See Figure 3 for Test Circuit)

Unless otherwise noted: $V_{CC} = +5V$, $V_{IN} = 0.7V$, $C_L = 8\text{ pF}$, Video Signal Output = 1 V_{PP} , $T_A = 25^\circ\text{C}$, $V_{ABL} = V_{CC}$.

Symbol	Parameter	Conditions	LM1253A			Units
			Min	Typ	Max	
V_{CCDET}	V_{CC} Undervoltage Detection Threshold			3.9		V
F_{FREE_RUN}	Free Run HBLANK Frequency		30		60	kHz
V_{IL}	Low Level Input Voltage for SDA and SCL Pins				1.5	V
V_{IH}	High Level Input Voltage for SDA and SCL Pins		3			V
V_{OL}	Low Level Output Voltage for SDA and SCL Pins	3 mA Sink Current	0		0.4	V

Note 1: Absolute Maximum Ratings indicate limits beyond which damage to the device may occur.

Note 2: Operating Ranges indicate conditions for which the device is functional, but do not guarantee specific performance limits. For guaranteed specifications and test conditions, see the Electrical Characteristics. The guaranteed specifications apply only for the test conditions listed. Some performance characteristics may change when the device is not operated under the listed test conditions.

Note 3: All voltages are measured with respect to GND, unless otherwise specified.

Note 4: Linearity Error = $100 \cdot (\text{step}_{\text{max}} - \text{step}_{\text{min}}) / \text{step}_{\text{ave}}$

Where: The input signal is a 16 step staircase signal waveform with 0.7 V_{P-P} level, subdivided into 16 equal steps, with each step approximately 100 ns in width

step_{max} is the maximum voltage step at the output

step_{min} is the minimum voltage step at the output

step_{ave} is the average voltage of the 16 steps at the output.

Note 5: Input from signal generator: $t_r, t_f < 1\text{ ns}$.

Note 6: ABL should provide smooth decrease in gain over the operational range of 0 dB to -5 dB

$\Delta A_{ABL} = A(V_{ABL} = V_{ABL\text{ MAX GAIN}}) - A(V_{ABL} = V_{ABL\text{ MIN GAIN}})$

Test Circuit

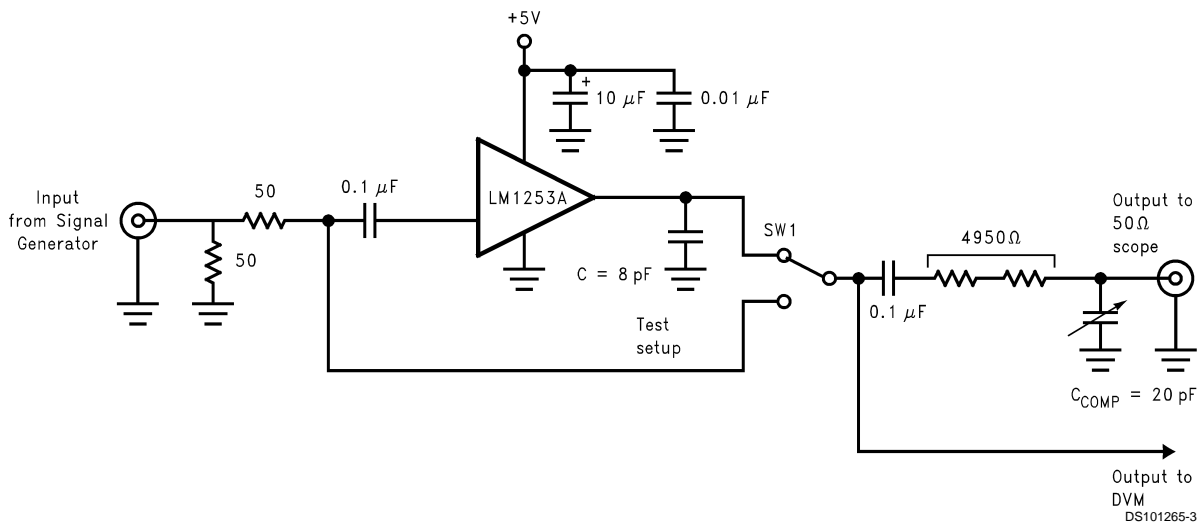

Note: 8 pF load includes parasitic capacitance

FIGURE 3. Test Circuit

Test Settings

TABLE 1. Control Test Settings

Control	No. of Bits	Basic Test Setting 1	Basic Test Setting 2	Basic Test Setting 3	Basic Test Setting 4
Contrast	7	Max (Hex 7F)	Max (Hex 7F)	Max (Hex 7F)	Max (Hex 7F)
R,G,B Gain	7	Max (Hex 7F)	Max (Hex 7F)	Set for 1 V_{P-P} on all Channels	Max (Hex 7F)
Brightness	8	Max (Hex FF)	Max (Hex FF)	Min (Hex 00)	Min (Hex 00)
R,G,B Bias	8	Max (Hex FF)	Max (Hex FF)	Min (Hex 00)	Min (Hex 00)
DC Offset	3	Min (Hex 07)	Max (Hex 00)	Min (Hex 07)	Min (Hex 07)
Pedestal Offset	3	Max (Hex 07)	Max (Hex 07)	Min (Hex 00)	Min (Hex 00)

Pin Descriptions

Pin 1— $R_{EXT} V_{REF}$ A 10 k Ω 1% resistor is connected to this pin to set up the internal current sources. The LM1253A is optimized for this value of resistor. A DC voltage only will be on this pin. Decreasing the value of this resistor will increase supply current while degrading performance; increasing the value of the resistor will decrease supply current and also degrade the performance. Do not place the resistor close to sources of heat such as the CRT driver. Figure 29 shows the components connected to pin 1, Figure 11 shows the internal schematic of pin 1.

Pin 2—V Blank Out This pin supplies a variable width, negative going pulse at the vertical rate to the CRT Driver. V Blank is triggered from the signal on pin 15, which comes from the vertical flyback. The CRT Driver supplies the pull up for this pin. The width of this pulse is set by the value in the VBLANKDUR register (8403h). Figures 4, 5, 6 show the resulting V Blank Out pulse with various values in register 8403h. The trace connecting pin 2 of the LM1253A to the LM2453 must be kept away from the output circuitry of the LM2453. Figure 29 shows the external schematic of pin 2, Figure 12 shows the internal schematic of pin 2.

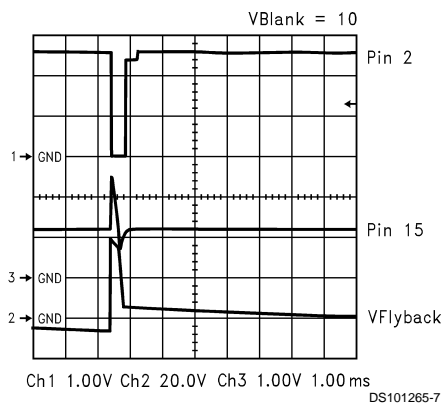

FIGURE 4. V Blank = 10

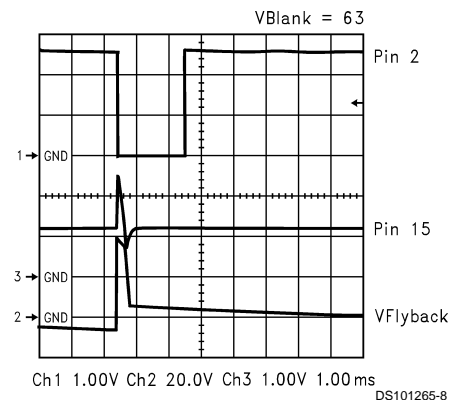

FIGURE 5. V Blank = 63

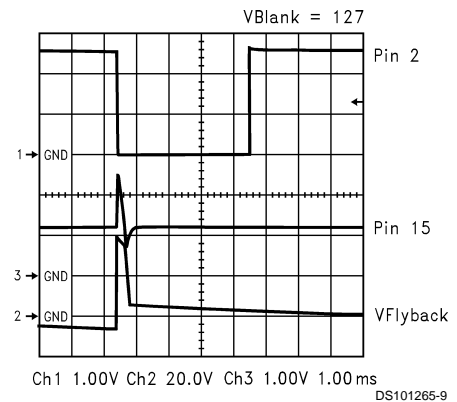

FIGURE 6. V Blank = 127

Pin 3— V_{REF} Cap A 0.1 μF capacitor is placed close to this pin to decouple V_{REF} . V_{REF} is used by the three video channel circuits to make the VideoPlex signal. Figure 29 shows the external schematic of pin 3, Figure 13 shows the internal schematic of pin 3.

Pin 4, 5, 6—Blue, Red, and Green Video In The red, blue, and green video signal is AC coupled into these pins. The value of the capacitors is very important as they also serve

Pin Descriptions (Continued)

as the DC clamp control capacitors. A value of 0.0047 μF is used in the demo boards. The schematic shown in *Figure 29* which has a series resistance of 33 Ω and clamp diodes to V_{CC} and ground should be used to protect the LM1253A from ESD. A good ground should be between the input connector and the LM1253A. The video traces should be kept short. *Figure 29* shows the external schematic of pins 4, 5, and 6, *Figure 14* shows the internal schematic of pins 4, 5, and 6.

Pin 7—Analog Ground Ground for the video section of the LM1253A. All ground pins of the LM1253A should be connected together by a ground plane under the LM1253A. See *Figure 31*, which shows a sample layout.

Pin 8—Analog Supply 5V supply for the video section of the preamp. A 0.1 μF capacitor should be connected between pin 7 and pin 8, as close as possible to the LM1253A. A 100 μF capacitor should also be connected between pin 7 and pin 8.

Pin 9—Analog Supply 5V supply for the PLL section of the LM1253A. A 0.1 μF capacitor should be connected between pin 9 and pin 7, as close as possible to the LM1253A.

Pin 10—PLL Ground Ground for the PLL section of the LM1253A. Only the PLL components connected to pin 11 should be connected to this ground pin. Pin 10 should also be connected to the ground plane under the LM1253A. All ground pins of the LM1253A should be connected together by a ground plane under the LM1253A. See *Figure 31*, which shows a sample layout.

Pin 11—PLL C A resistor capacitor network is connected to this pin. It is used to convert the charge current of the charge pump of the PLL into a voltage that is used to control the variable oscillator. These components should be located very close to the LM1253A with a short ground trace to pin 10.

The recommended values are $R_{28} = 6.2 \text{ k}\Omega$, $C_{23} = 0.1 \mu\text{F}$, and $C_{33} = 2.2 \text{ nF}$. When these component values are used the range and gain values in *Table 12* can be loaded into register 843Eh.

An example layout is shown in *Figure 31*, *Figure 29* shows the external schematic of pin 11, *Figure 15* shows the internal schematic.

Pin 12—ABL The Auto Beam Limit control reduces the gain of the video amplifiers in response to a control voltage proportional to the CRT beam current. The ABL acts on all three channels in an identical manner. This is required for CRT life and X-ray protection. The beam current limit circuit application is as shown in *Figure 7*: when no current is being drawn by the EHT supply, current flows from the supply rail through the ABL resistor and into the ABL input of the IC. The IC clamps the input voltage to a low impedance voltage source (the 5V supply rail).

When current is drawn from the EHT supply, the current passes through the ABL resistor, and reduces the current flowing into the ABL input of the IC.

When the EHT current is high enough, the current flowing into the ABL input of the IC drops to zero. This current level determines the ABL threshold and is given by:

$$I_{ABL} = \frac{V_S - V_{ABL\ TH}}{R_{ABL}}$$

Where:

V_S is the external supply (usually the CRT driver supply rail, about 80V)

$V_{ABL\ TH}$ is the threshold ABL voltage of the IC

R_{ABL} is the ABL resistor value

I_{ABL} is the ABL limit

When the voltage on the ABL input drops below the ABL threshold of the pre-amp, the gain of the pre-amp decreases, which is shown in *Figure 8*, which reduces the beam current. A feedback loop is thus established which acts to prevent the average beam current exceeding I_{ABL} .

Figure 29 shows the external schematic of pin 12, *Figure 16* shows the internal schematic.

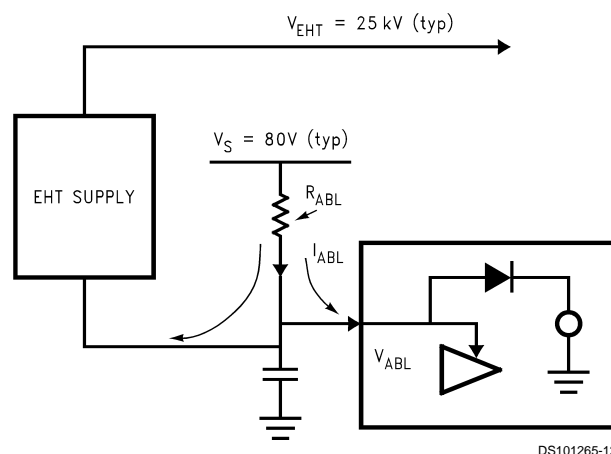

FIGURE 7. ABL

Pin Descriptions (Continued)

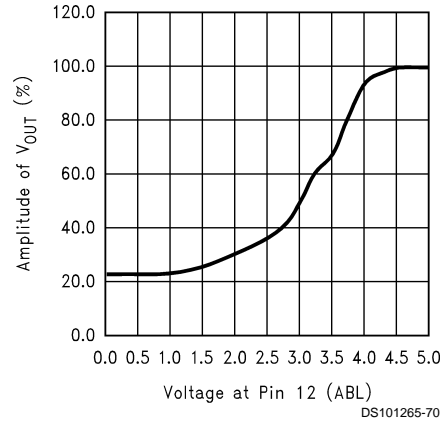

FIGURE 8. Effect of ABL Voltage on V_{OUT}

Pin 13—Clamp A positive going clamp signal is input on this pin. Using this signal black level clamping of the video is carried out directly on the input video that is AC coupled into the high impedance preamplifier input, thus eliminating the need for additional black level clamp capacitors. *Figure 29* shows the external schematic of pin 13, *Figure 17* shows the internal schematic. An optional capacitor to ground may be needed if noise interferes with the clamp signal.

Pin 14—H Flyback H Flyback is an analog signal input from the monitor horizontal scan. HBLANK is a digital signal

derived from the horizontal flyback pulse as shown in *Figure 9*. An optional capacitor and/or resistor to ground may be needed if noise interferes with the H Flyback signal.

The horizontal flyback from the monitor must be a clean signal. There should be no ringing or other noise on the flyback.

Pin Descriptions (Continued)

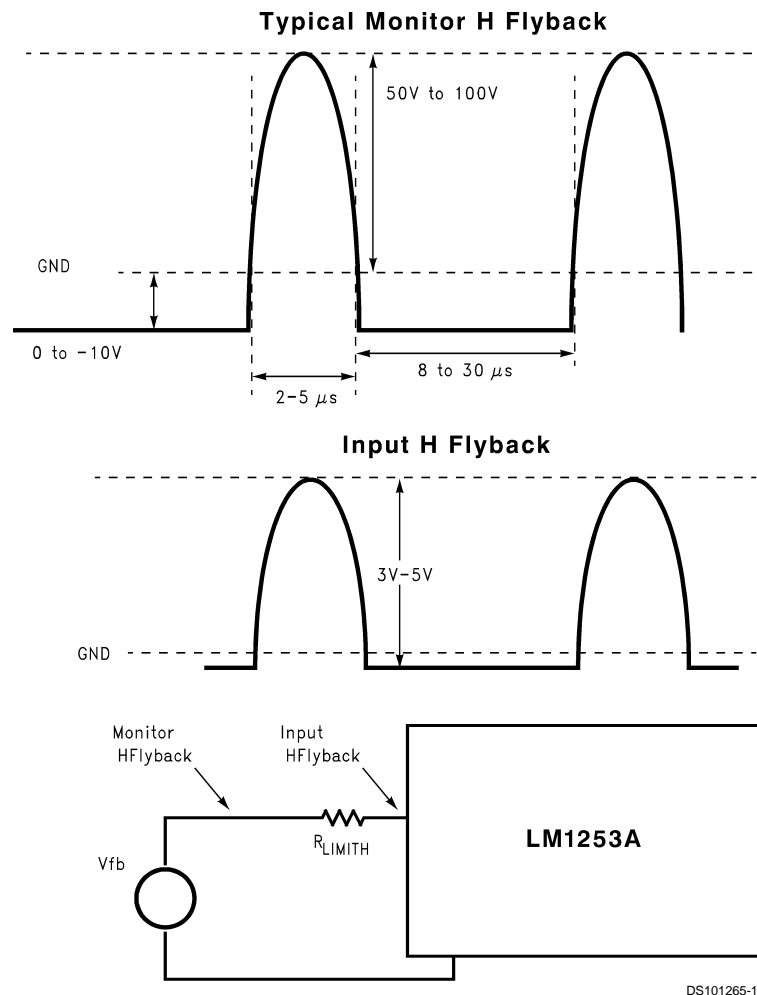

FIGURE 9. H Flyback Input Pulse

R_{LIMITH} is set to limit the input current into the IC to a maximum value of +1 mA during flyback and $-150 \mu\text{A}$ during normal forward scan. For example if an h flyback with a peak of 100V is used, $R_{LIMITH} = 100 \text{ k}\Omega$. The internal input impedance of pin 14 is low to limit the maximum voltage swing at the input to within the supply rail and ground. The IC interface circuit creates a digital signal from this waveform, which is used as the blanking signal, and termed HBLANK. This signal is used by the video amplifier for blanking the video and by the OSD generator as the horizontal sync reference for the PLL.

Loss of the horizontal flyback pulse implies that the monitor is not scanning, and therefore no image is being displayed. The HBLANK pulse is still required by the LM2453 CRT driver in order to maintain correct bias conditions in the CRT until the power supplies are switched off, but video will be set at black level to prevent front of screen problems, using the NO_VID line. See also the *Loss of Horizontal Flyback* section.

Figure 29 shows the external schematic of pin 14, Figure 18 shows the internal schematic.

Pin 15—V Flyback This is an analog signal from the monitor vertical scan. The analog waveform is AC coupled and fed to the input of the IC via a current limiting resistor to

prevent the positive and negative excursions of the signal causing excessive current or voltage swing at the input to the IC. See Figure 10.

R_{LIMITV} is set to limit the maximum input voltage swing into the IC to less than the supply rails. The input to the IC is positive edge triggered, and ignores the falling edge. Because of horizontal rate noise on the waveform, the input buffer incorporates hysteresis, triggering at a positive going threshold of V_{VTH+} and a negative going threshold of V_{VTH-} .

The input buffer produces a digital signal VSTART which is used to start the VBLANK timer. The positive rising edge of VSTART sets a counter timer, which counts horizontal periods using the HBLANK signal. The timer resets VBLANK when it reaches the value preset in the register VCOUNT (set by the micro-controller over I²C). While the output VBLANK is active, an AND function prevents any further transitions on the VSTART waveform from retriggering the counter.

The positive edge of the VSTART signal is initially transmitted through to VBLANK through an OR function, as the timer may take up to one horizontal line period to begin timing the duration of the pulse. The application must ensure that the

Pin Descriptions (Continued)

VFLYBACK vertical flyback pulse is kept high during that initial period to prevent the output VBLANK from switching between high and low states.

Loss of vertical flyback pulse implies that the monitor is not scanning, and therefore no image is being displayed. The

VBLANK pulses are still required by the LM2453 CRT driver in order to maintain correct bias conditions in the CRT until the power supplies are switched off, but video will be set at black level to prevent front of screen problems, using the NO_VID line. See also the *Loss of Vertical Flyback Pulse* section. *Figure 29* shows the external schematic of pin 15, *Figure 19* shows the internal schematic.

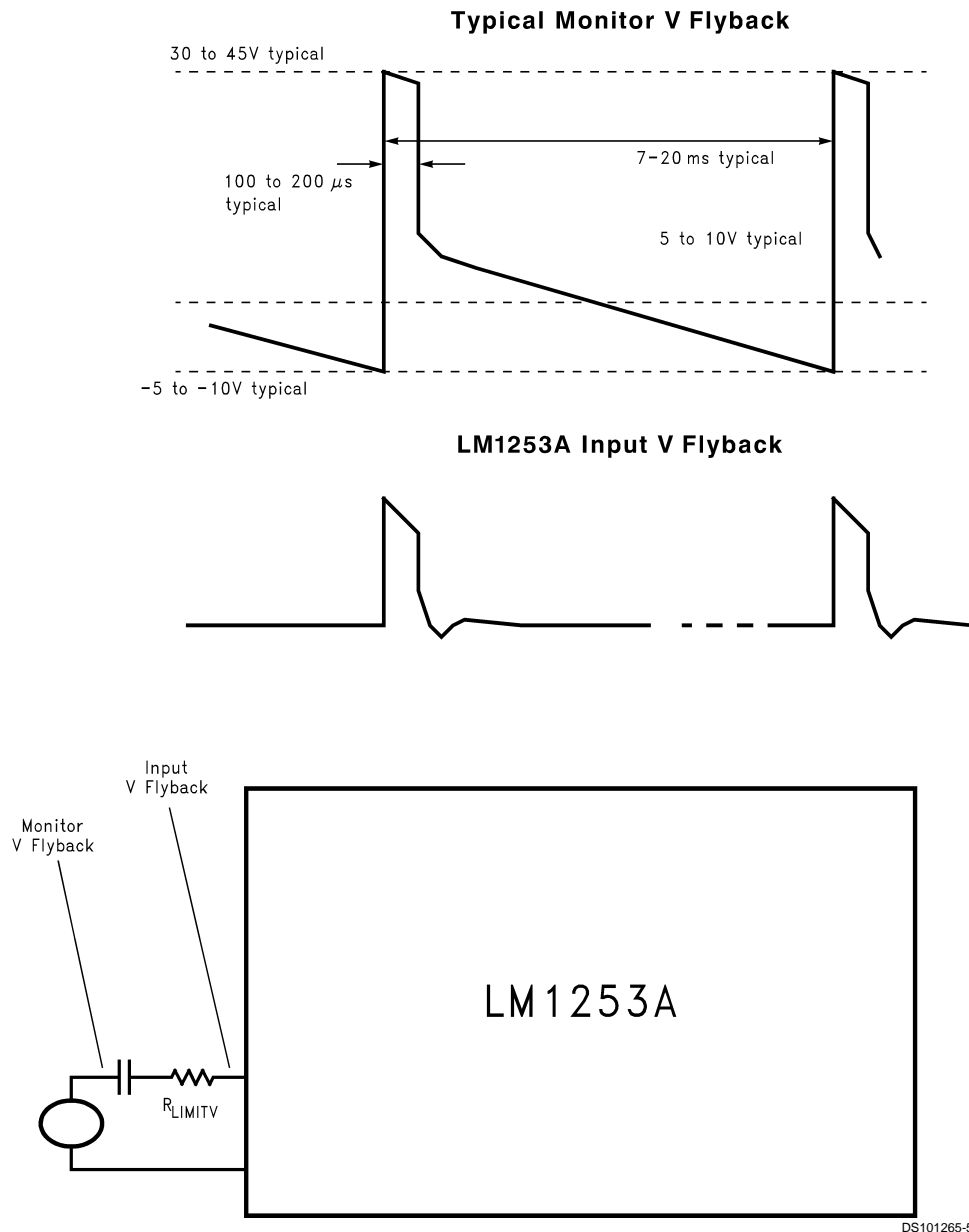

FIGURE 10. Vertical Flyback Input Pulse

Pin 16—SDA The I²C data line. A pull up resistor of about 2 k Ω should be connected between this pin and +5V. A 300 Ω resistor should be connected in series with the data line to protect the IC against arcing. *Figure 29* shows the external schematic of pin 16, *Figure 20* shows the internal schematic.

Pin 17—SCL The I²C clock line. A pull up resistor of about 2 k Ω should be connected between this pin and +5V. A 300 Ω resistor should be connected in series with the clock line to protect the IC against arcing. *Figure 29* shows the external schematic of pin 17, *Figure 20* shows the internal schematic.

Pin 18—Digital Ground Ground for the OSD section of the LM1253A. All ground pins of the LM1253A should be connected together by a ground plane under the LM1253A. See *Figure 31*, which shows a sample layout.

Pin 19—Digital Supply 5V supply for the OSD section of the LM1253A. A 0.1 μ F capacitor should be connected between pin 18 and pin 19, as close as possible to the LM1253A.

Pin Descriptions (Continued)

Pin 20—Digital Supply 5V supply for the OSD section of the LM1253A. Pins 19 and 20 should be tied together under normal operating conditions.

Pin 21—Analog Supply 5V supply for the video section of the preamp. A 0.1 μF capacitor should be connected between pin 21 and pin 22, as close as possible to the LM1253A.

Pin 22—Analog Ground Ground for the video section of the LM1253A. All ground pins of the LM1253A should be connected together by a ground plane under the LM1253A. See *Figure 31*, which shows a sample layout.

Pin 23, 24, and 25—Green, Red, and Blue Video Out These pins output the red, green, and blue video information in the VideoPlex format. These pins are connected to the LM2453 using as short of traces as possible. An inductor should be in series with the trace between the preamp and CRT driver. The value of this inductor depends on the board layout. *Figures 29, 30* show the external schematic of pins 23, 24, and 25, *Figure 21* shows the internal schematic.

Pin 26— V_{REF} Out The voltage that the VideoPlex signal is referenced to is output on this pin. A 0.1 μF capacitor should be connected between this pin and ground and be located close to the LM1253A. This pin is connected to the V_{REF} pin of the LM2453. A 0.1 μF capacitor also needs to be connected very close to the LM2453. A 100 μF capacitor should also be connected to this trace. *Figures 29, 30* show the external schematic of pin 26, *Figure 22* shows the internal schematic.

Pin 27—Analog Ground Ground for the band gap reference section of the LM1253A. All ground pins of the LM1253A should be connected together by a ground plane under the LM1253A. See *Figure 31*, which shows a sample layout.

Pin 28—Analog Supply 5V supply for the band gap reference section of the preamp. A 0.1 μF capacitor should be connected between pin 27 and pin 28, as close as possible to the LM1253A. See *Figure 31*, which shows a sample layout.

Input/Output Schematics

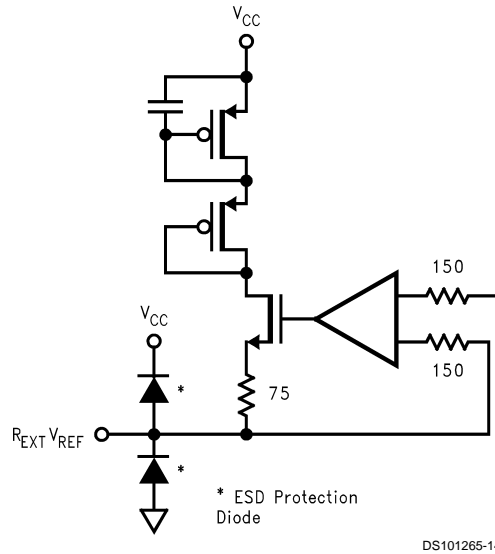

FIGURE 11. Pin 1 ($R_{\text{EXT}} V_{\text{REF}}$)

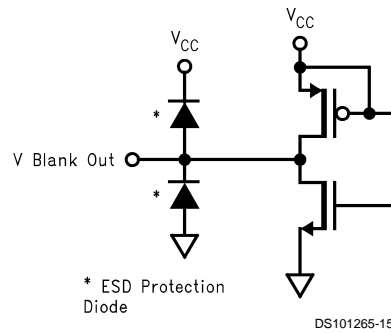

FIGURE 12. Pin 2 (V Blank Out)

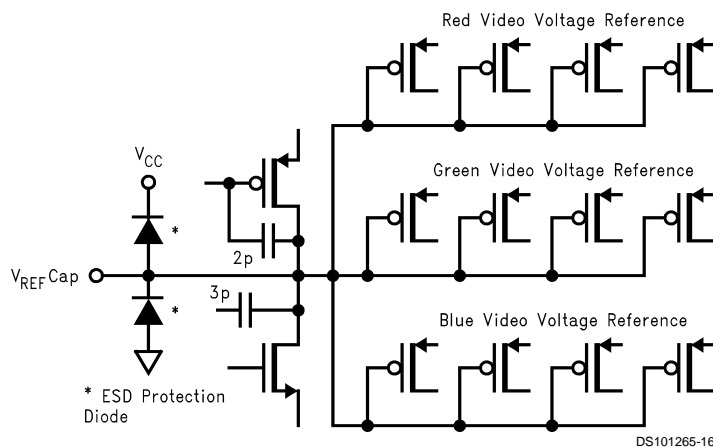

FIGURE 13. Pin 3 (V_{REF} Cap)

Input/Output Schematics (Continued)

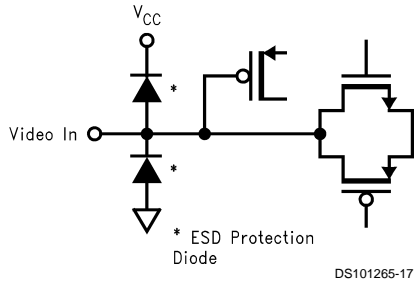

FIGURE 14. Pins 4, 5, and 6 (Video In)

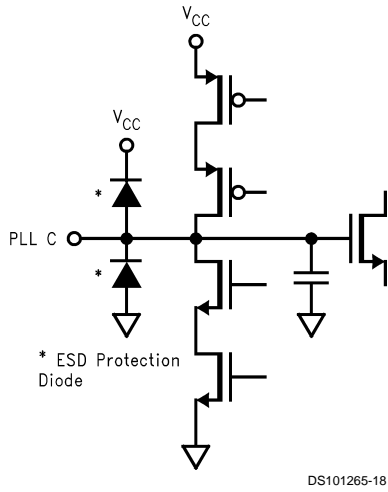

FIGURE 15. Pin 11 (PLL C)

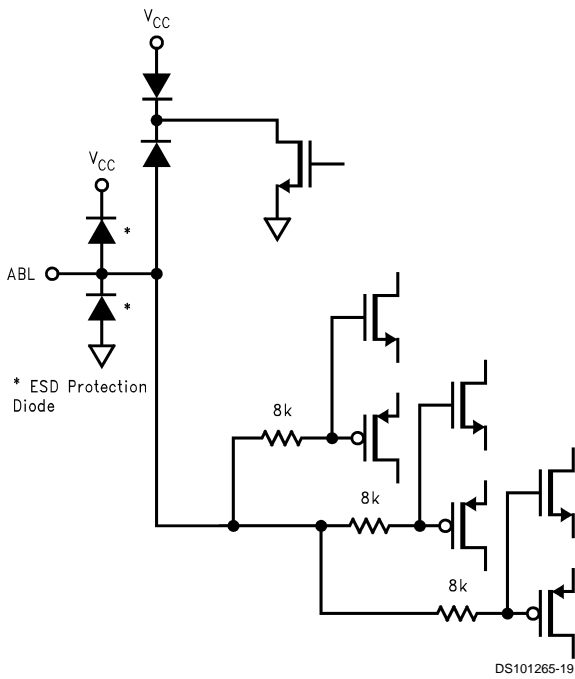

FIGURE 16. Pin 12 (ABL)

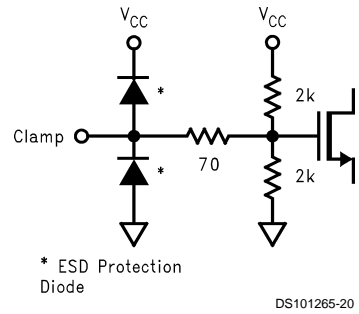

FIGURE 17. Pin 13 (Clamp)

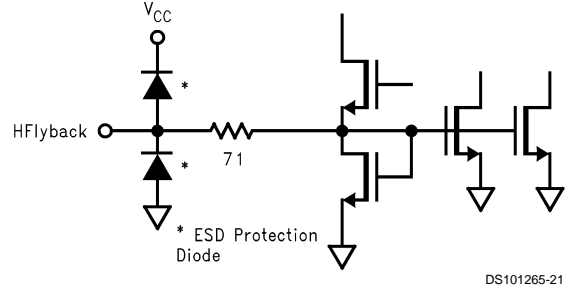

FIGURE 18. Pin 14 (H Flyback)

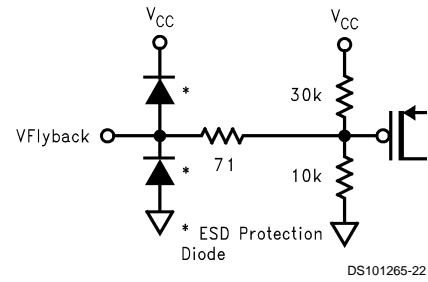

FIGURE 19. Pin 15 (V Flyback)

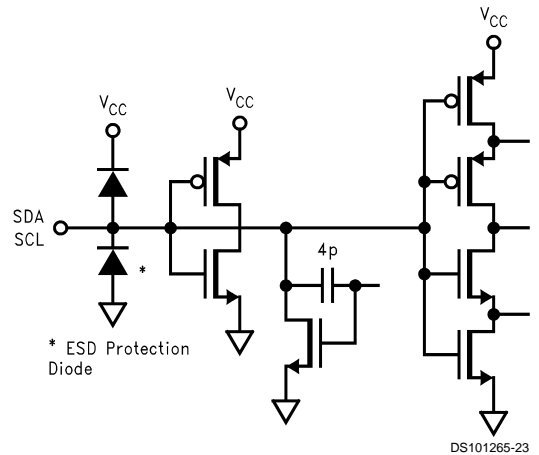

FIGURE 20. Pins 16 and 17 (SDA and SCL)

Input/Output Schematics (Continued)

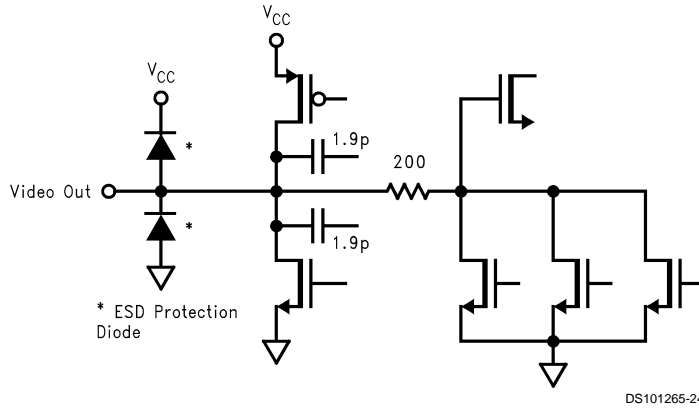

FIGURE 21. Pins 23, 24, and 25 (Video Out)

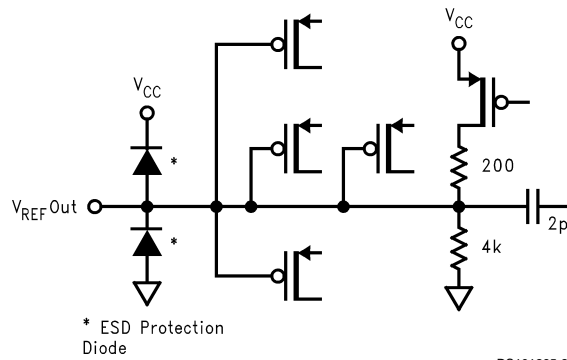

FIGURE 22. Pin 26 V_{REF} Out

National VideoPlex Video System

The LM1253A CRT Pre-Amp in conjunction with the LM2453 CRT driver uses the National VideoPlex multiplexed video

signal to send the video signal and DC clamp level from the pre-amp to the CRT driver. The basic signal scheme is shown in *Figure 23*.

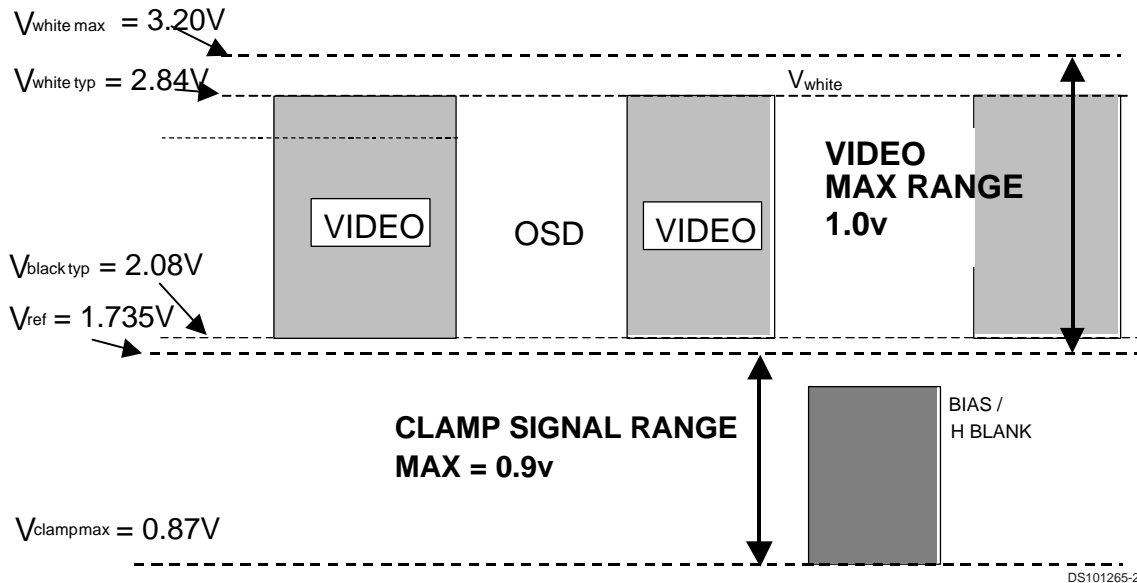

FIGURE 23. National VideoPlex Video Signal (Pre-Amp Output)

National VideoPlex Video System

(Continued)

The response of the LM2453 CRT driver to the VideoPlex signal from the LM1253A Pre-Amp is shown in *Figure 24*. Note that there are two sections in the video signal; the video

information is above V_{REF} and the clamp information is below V_{REF} . The signals on the video out and clamp pins of the LM2453 for an arbitrary video waveform from the LM1253A is shown in *Figure 25*.

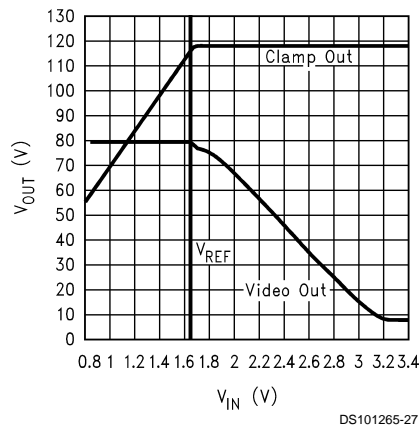

DS101265-27

FIGURE 24. DC I/O Transfer Characteristics for the LM2453 CRT Driver
(Test Conditions: $V_{REF} = 1.65V$, $V_{CC1} = 80V$, $V_{BB} = 8V$)

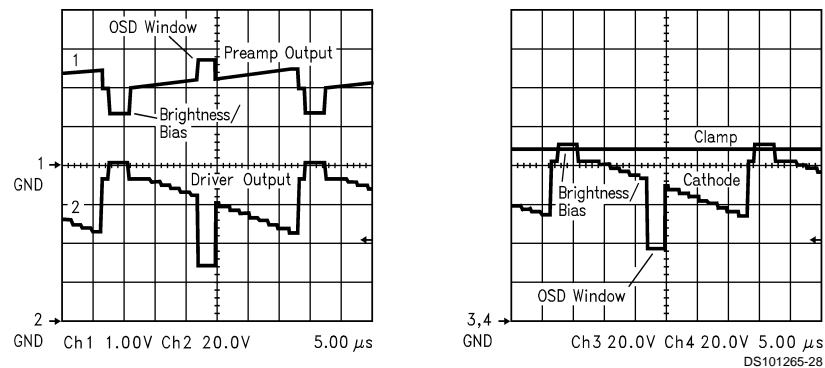

DS101265-28

FIGURE 25. LM2453 Input and Output Waveforms

ESD and Arc-Over Protection

The LM1253A incorporates full ESD protection with special consideration given to maximizing arc-over robustness. The monitor designer must still use good circuit design and PCB layout techniques. The human body model ESD susceptibility of the LM1253A is 2 kV, however many monitor manufacturers are now testing their monitors to the level 4 of the IEC 801-2 specification which requires the monitor to survive an 8 kV discharge. External ESD protection is needed to survive this level of ESD. The LM1253A provides excellent protection against both ESD and arc-over, but this is not a substitute for good PCB layout.

Figure 26 show the recommended input protection for the LM1253A. This provides the best protection against ESD. When this protection is combined with good PCB layout the LM1253A will easily survive the IEC 801-2 level 4 testing (8 kV ESD). It is strongly recommended that the protection diodes be added as shown in *Figure 26*. The 1N4148 diode has a maximum capacitance of 4 pF which will have little effect on the response of the video system due to the low impedance of the input video.

The ESD cells of the LM1253A also provide good protection against arc-over, however good PCB layout is necessary. The LM1253A should not be exposed directly to the voltages that may occur during arc-over. The main vulnerability of the LM1253A to arc-over is though the ground traces on the PCB. For proper protection all ground connections associated with the LM1253A, including the grounds to the bypass capacitors, must have short returns to the ground pins. A significant ground plane should be used to connect all the LM1253A grounds. *Figure 31*, which shows the demo board layout, is an excellent example of an effective ground plane. The list below should be followed to ensure a PCB with good grounding:

- All grounds associated with the LM1253A should be connected together through a large ground plane.
- CRT driver ground is connected to the video pre-amp ground at one point.
- CRT and arc protection grounds are connected directly to the chassis or main ground. There is no arc-over current flow from these grounds through the LM1253A grounds.
- Input signal traces for SDA, SCL, H Flyback, V Flyback, Clamp should be kept away from the LM2453 and all traces that an arc can travel on.

ESD and Arc-Over Protection

(Continued)

- Output signal traces of the LM1253A (video, V_{BLANK} , V_{REF}) should be kept away from traces that carry the output signals of the LM2453.

If any one of the above suggestions is not followed the LM1253A may become more vulnerable to arc-over. Improper grounding is by far the most common cause of a video pre-amp failure during arc-over.

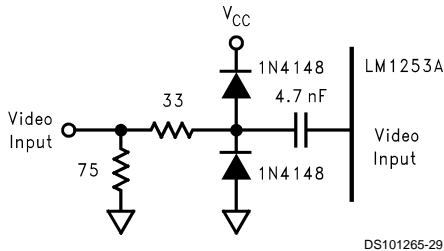

DS101265-29

FIGURE 26. Recommended Video Input ESD Protection

The I²C specification recommends that the SDA and SCL pins should be protected from arc-over. This is done by adding a resistor in series with each pin. Figure 27 shows how the resistors are connected to the SDA and SCL lines.

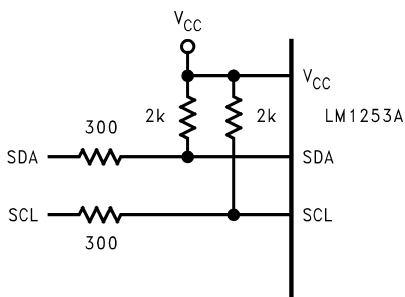

DS101265-30

FIGURE 27. Recommended Arc-Over Protection for SDA and SCL Pins

Pre-Amp Functional Description

Figure 1 shows the block diagram of the LM1253A. The video signal is input to the LM1253A through the circuit shown in Figure 26. Black level clamping is carried out directly on the AC coupled input signal at the input of the high impedance buffer amplifier, thus eliminating the need for black level clamp capacitors. The following sections then modify the input video signal:

- Contrast Attenuator—Sets the contrast level of the video signal for all three channels.
- Auto Beam Limit—Reduces the gain of all three video amplifiers in response to a control voltage proportional to the CRT beam current.
- Gain Attenuator—Separately sets the gain for each video channel.
- Brightness—Sets the brightness for all three channels.
- Bias—Adds an offset to the brightness controls for all three video channels.
- Pedestal—Adds a dc voltage offset to the brightness control, in order that bi-directional control of the brightness control is always possible at all bias voltage settings.
- Source Select—Switches between the input video signal and the analog OSD signal generated by the 3 bit pallet DAC control block.
- DC Offset—Adds a dc voltage offset to all three video outputs.

The above sections use the registers shown in Table 2. Figure 28 shows which section of the output video and clamp signal each register controls.

Pre-Amp Functional Description (Continued)

TABLE 2. Registers Controlling the Output Video and Clamp Signal

Parameter	Address	Size	Description	Default
BGAIN	8430h	7 Bit	Blue Channel Gain	60h
GGAIN	8431h	7 Bit	Green Channel Gain	60h
RGAIN	8432h	7 Bit	Red Channel Gain	60h
CONTRAST	8433h	7 Bit	Overall Gain of All Three Channels	60h
BBIAS	8434h	8 Bit	Blue Bias Clamp Pulse Amplitude	80h
GBIAS	8435h	8 Bit	Green Bias Clamp Pulse Amplitude	80h
RBIAS	8436h	8 Bit	Red Bias Clamp Pulse Amplitude	80h
BRIGHTNESS	8437h	8 Bit	Amplitude of Brightness Clamp Pulse of All 3 Channels	80h
PEDESTAL	8438h Bits 7–5	3 Bit	Offset to the Brightness Control	4h
OSD CONTRAST	8438h Bits 4–3	2 Bit	OSD Gain	2h
DC OFFSET	8438h Bits 2–0	3 Bit	Active Video DC Offset of All 3 Channels	4h

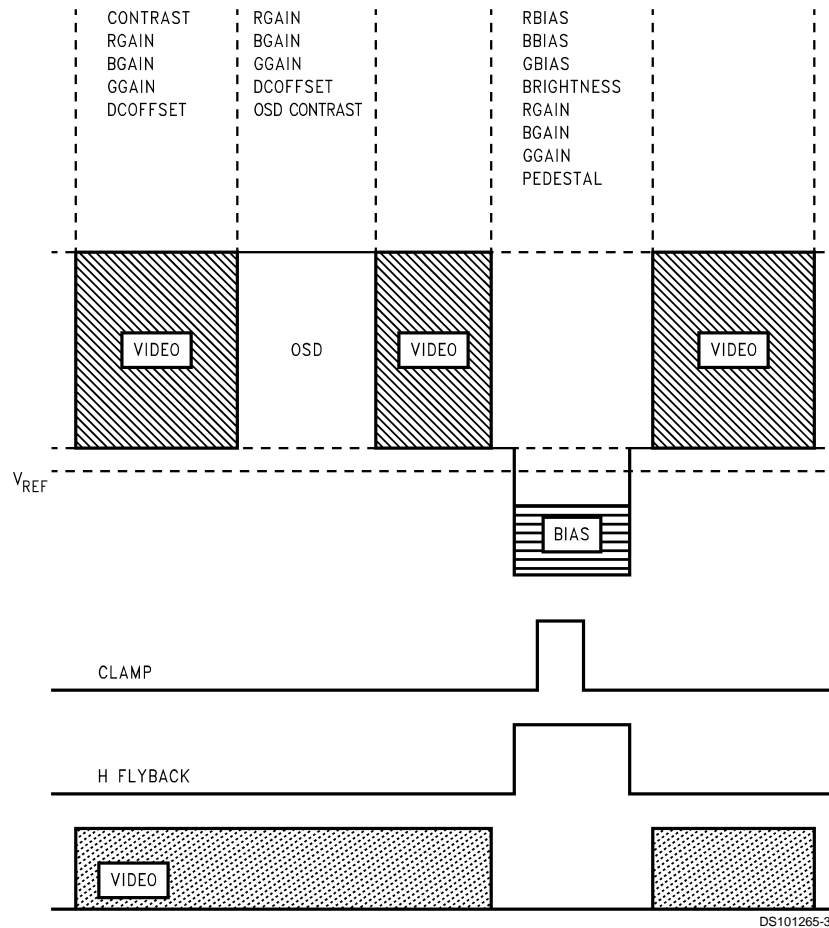

FIGURE 28. Register Control of the Output Video and Clamp Signal

An active horizontal blanking signal is added to the video at the output, giving excellent smear performance, and preventing video content dependent DC bias offsets as a result of high frequency overshoot.

The outputs are referenced to a DC level (V_{REF}) produced by the LM1253A preamp, and so are guaranteed to provide stable DC operating levels within the system without the need for additional external feedback components.

Pre-Amp Functional Description

(Continued)

Active Video Transfer Characteristic

Gain, contrast, and DC Offset control the amplitude of the active video. The Contrast Control range is 20 dB (10X) and the Gain Control range is 10 dB (3.2X). The DC offset can vary the active video output level by about 470 mV in total, allowing a total range of adjustment of about 24V in seven 3.4V steps at the output of a typical LM2453 CRT driver.

OSD Transfer Characteristic

Gain, DC Offset, and OSD Contrast control the amplitude of the OSD signal. The OSD is not affected by the Brightness control, but is proportional to the Gain control, with a gain control range of 10 dB (3.2X). The DC offset will affect the OSD output level by 470 mV in total. The OSD Contrast will change the amplitude of the OSD output level by 610 mV in total.

Brightness/Bias Transfer Characteristic

Bias, Brightness, Gain, and Pedestal control the amplitude of the brightness/bias (clamp) portion of the signal. The bias control range sets the brightness/bias pulse between 0.12V and 0.55V below the value of V_{REF} during blanking. The bias voltage is unaffected by changes in the other controls. The brightness control is bi-directional and adds or subtracts an additional amount of between $-0.2V$ and $+0.2V$ to the brightness/bias pulse during blanking, when gain is set to maximum. If gain is reduced, the brightness output voltage is reduced in proportion to allow gain tracking of the brightness control. The Pedestal controls the offset to the brightness control, in order that bi-directional operation of the brightness control is always possible at all bias voltage settings.

Auto Beam Limit Control

The Auto Beam Limit control reduces the gain of the video amplifier in response to a control voltage proportional to the CRT beam current. It is not recommended that this input be used as an analog contrast control.

Horizontal Phase Locked Loop

A phase locked oscillator produces a pixel clock for the OSD generator. This oscillator takes the HBLANK signal as the sync signal. A programmable divider sets the divide ratio and thus the number of pixels on a horizontal line.

Fault Operation

Loss of Vertical Flyback Pulse

Loss of vertical flyback pulse implies that the monitor is not scanning, and therefore no image is being displayed. The VBLANK pulses are still required by the LM2453 CRT driver in order to maintain correct bias conditions in the CRT until the power supplies are switched off, but video is set at black level.

Note also that interlace mode is supported by the LM1253A. In interlace mode, a frame is composed of two sequential fields. In the first field, the odd lines are displayed. In the second field the even lines are displayed. A complete frame consists of an odd number of horizontal lines, so that each field contains a half line. This will result in an alternate half line phase difference between each field of the VFLYBACK pulse with respect to the HBLANK pulse.

Loss of Horizontal Flyback

Loss of horizontal flyback pulse implies that the monitor is not scanning, and therefore no image is being displayed. The HBLANK pulse is still required by the LM2453 CRT driver in order to maintain correct bias conditions in the CRT until the power supplies are switched off, but video is set at black level.

In the absence of an externally supplied horizontal flyback pulse, the PLL will free run and generate its own HBLANK pulse. The PLL free run pulse will be gated into the HBLANK line to the pre-amp to allow normal operation of the pre-amp and driver biasing.

V_{CC} Detect

The V_{CC} power supply will be continuously monitored by the LM1253A. Should the V_{CC} supply drop to less than V_{CCDET} then the video signal will be set to V_{REF} .

The device will continue to operate down to V_{CCDET} , although some parameters may fall outside of specification when the supply drops below V_{CCMIN} .

Power Save Mode

Procedure To Put The LM1253A Into Power Save Mode or Power Off Blanking

If the monitor has a power save mode the following procedure should be used to put the LM1253A into power save mode. This should be used for both power save modes initiated from the video card and power save modes initiated by a user on the front panel of the monitor.

1. Set Bias and Brightness registers (8434h – 8437h) to 0.
2. Set the LM1253A to blank video by setting register 8439h to 01h.
3. Turn off the 8V and 80V supply to the LM2453.
4. Set the LM1253A to power save by setting register 8439h to 02h.

Schematics

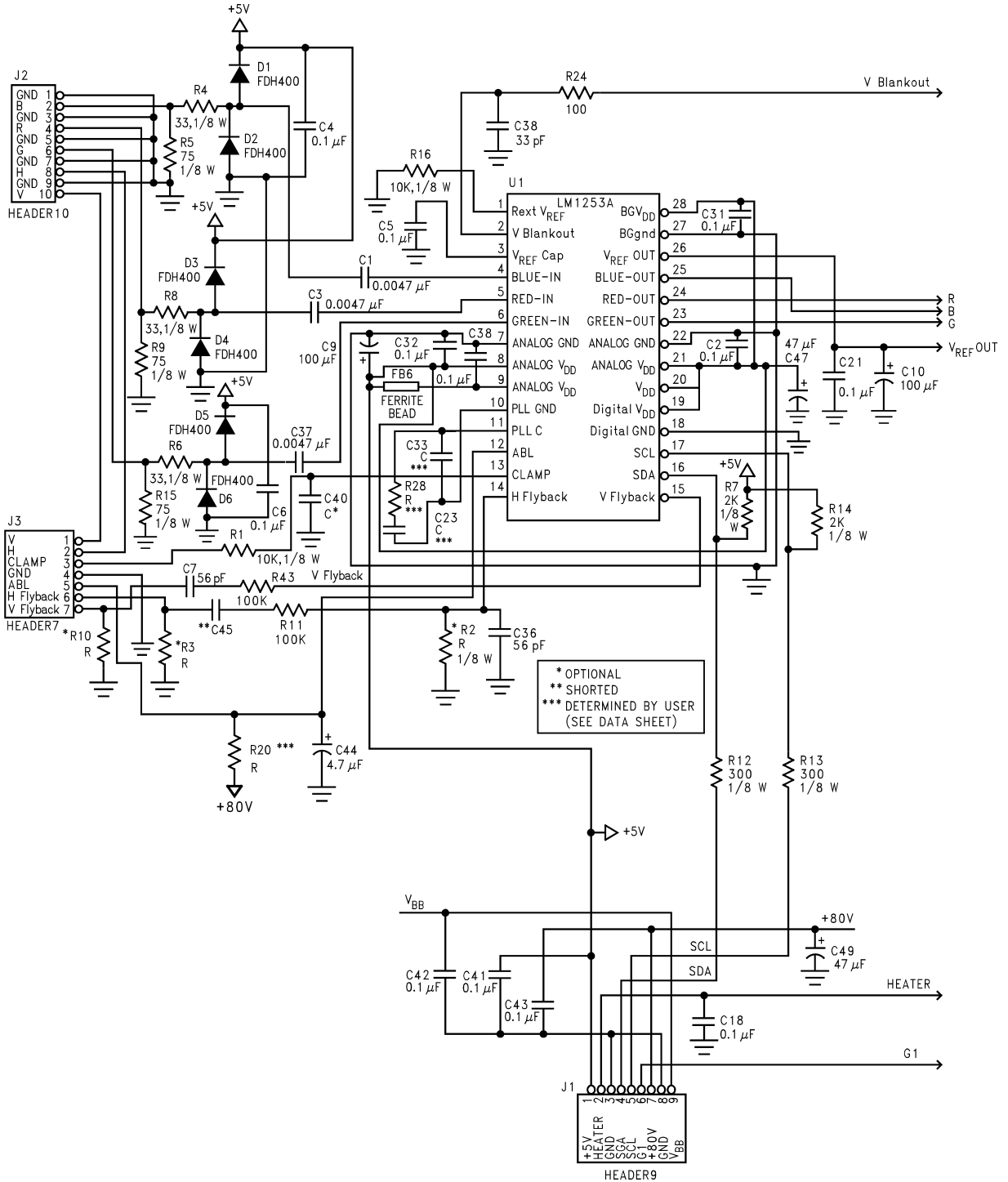

FIGURE 29. LM1253A/LM2453 Demo Board Schematic

DS101265-34

Schematics (Continued)

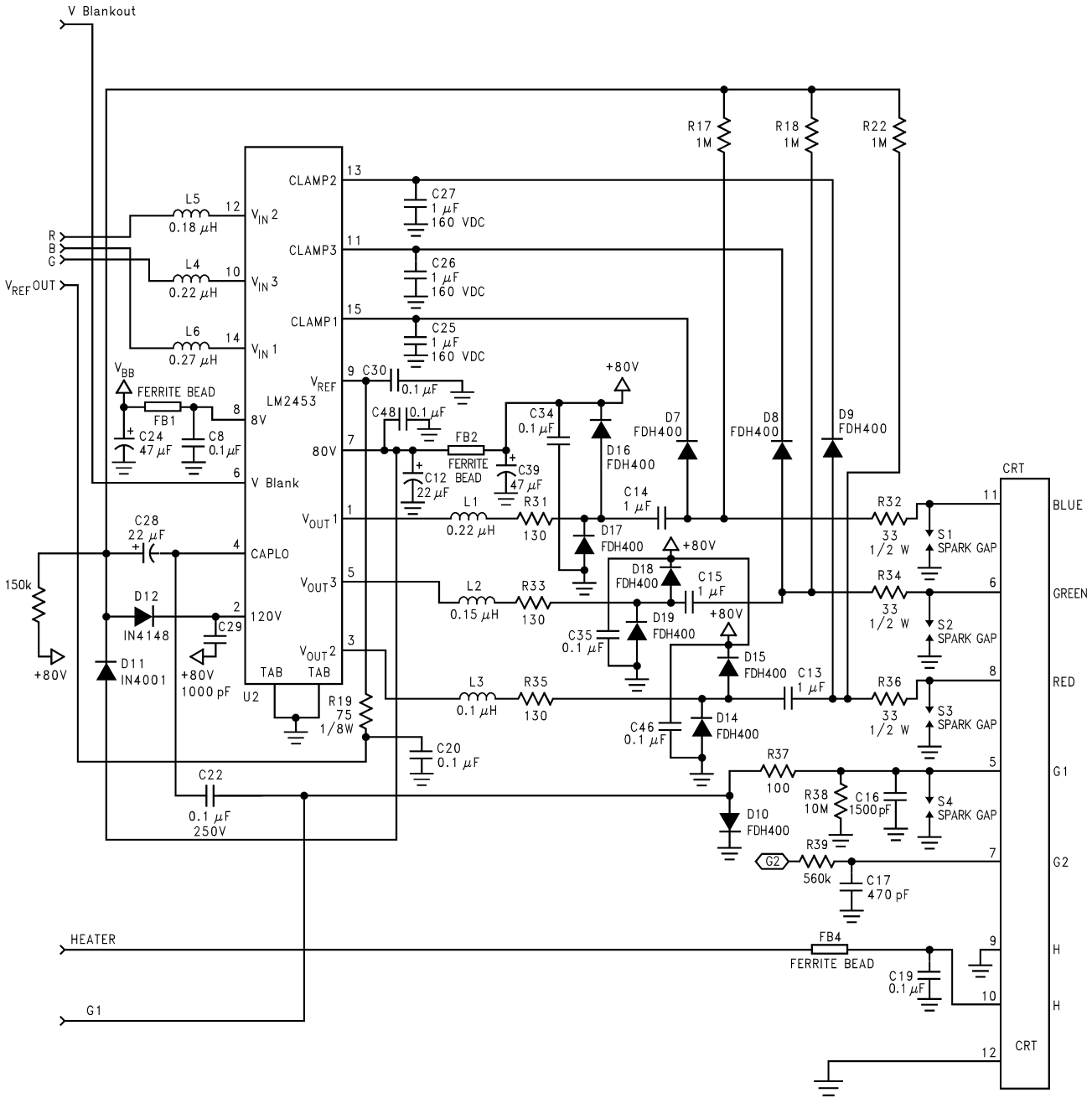
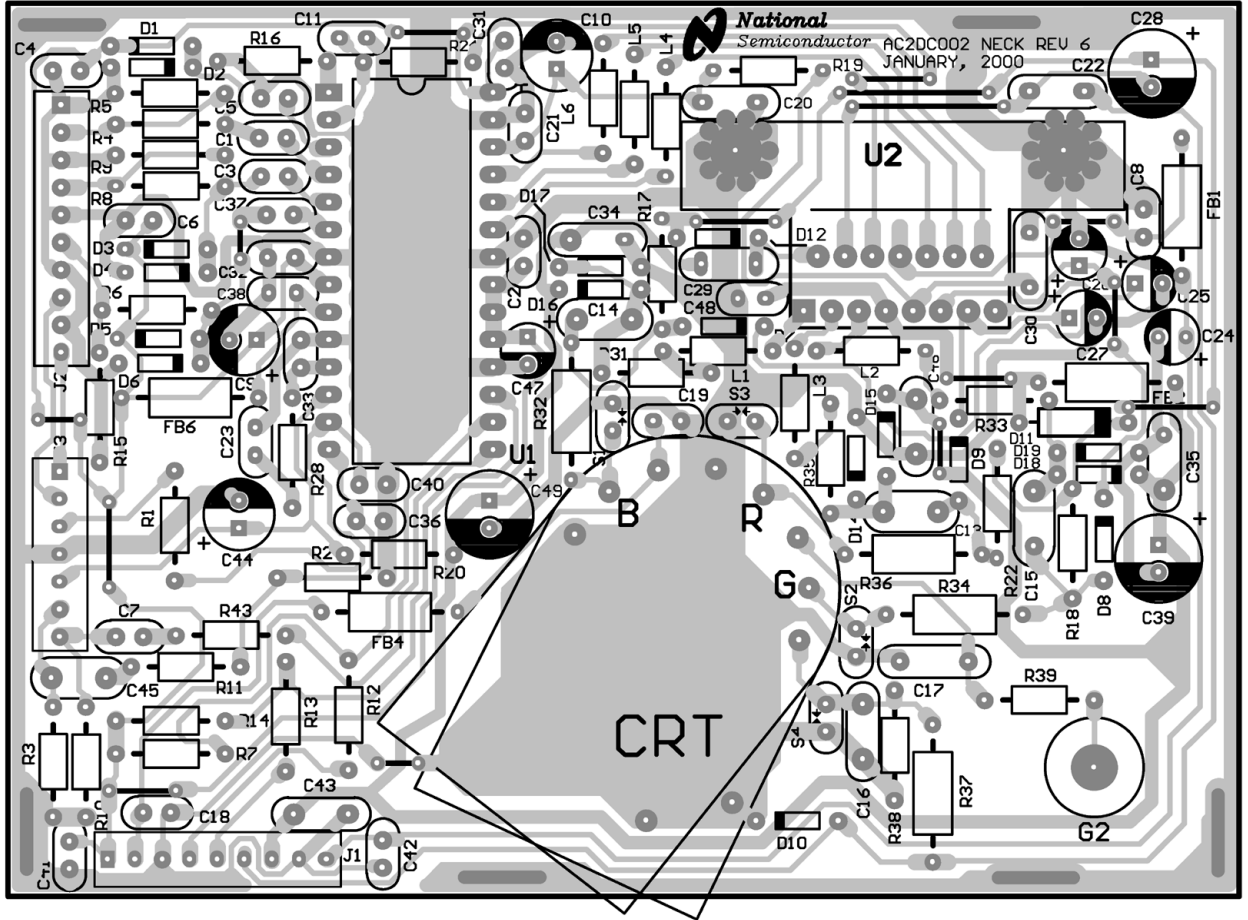

FIGURE 30. LM1253A/LM2453 Demo Board Schematic (continued)

DS101265-69

PCB Layout



DS101265-35

FIGURE 31. LM1253A/LM2453 Demo Board Layout

OSD Generator Operation

Page Operation

The block diagram of the OSD generator is shown *Figure 32*.

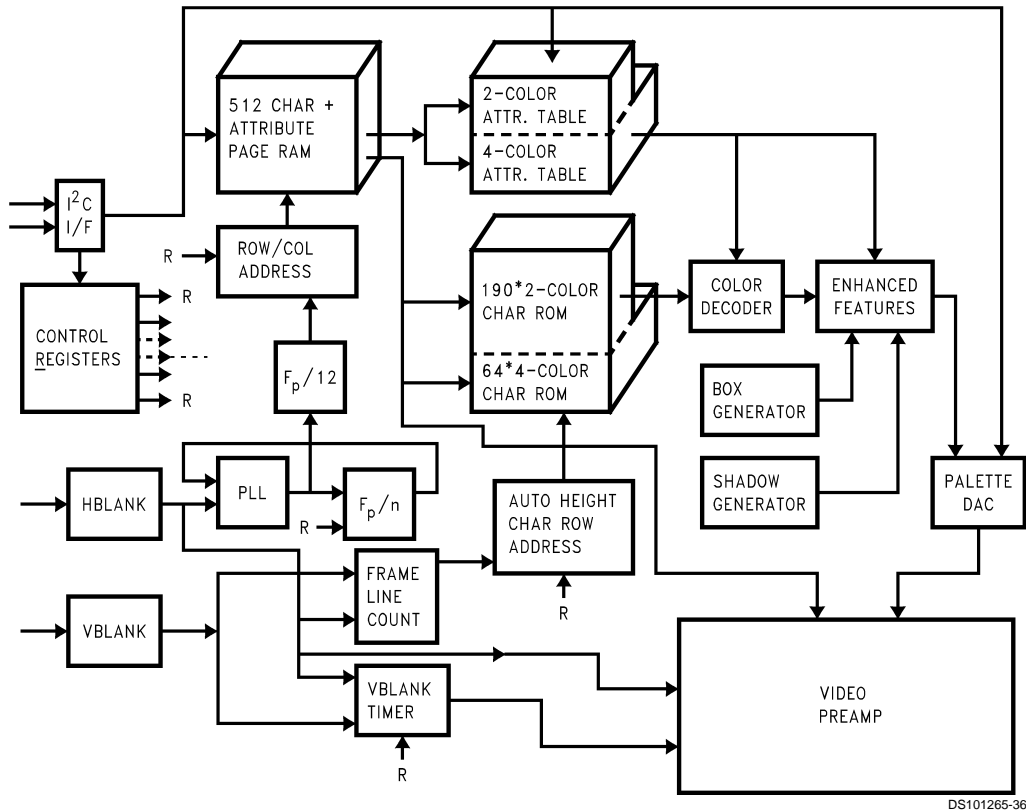

FIGURE 32. Block Diagram of the OSD Generator

Video information is created using any of the 256 pre-defined characters stored in the mask programmed ROM. Each character has a unique 8 bit code that is used as its address. Consecutive rows of characters make up the displayed window. These characters can be stored in the page RAM, written under I²C controlled commands by the monitor micro-controller. Each row can contain any number of characters up to the limit of the displayable line length, although some restrictions concerning the enhanced features apply on character rows longer than 32 characters

The number of characters across the width and height of the page can be varied under I²C control, but the total number of characters that can be stored and displayed on the screen is limited to 512 including any row end, skip line, and window end control characters. The horizontal and vertical start position can also be programmed under I²C control.

OSD Video DAC

The OSD DAC is controlled by the 9 bit (3x9 bits) OSD video information coming from the pixel serializer look-up table.

The OSD DAC is shown in the *Figure 33*, where the gain is programmable by the 2 bit OSD CONTRAST register, in 4 stages to give the required OSD signal.

The analog signal created by the OSD DACs is biased with respect to V_{REF} .

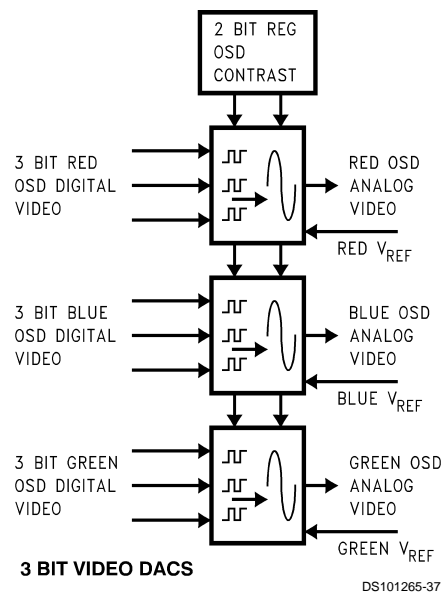

FIGURE 33. Block Diagram of OSD DACs

OSD Generator Operation (Continued)

OSD Video Timing

The OSD SELECT signal switches the source of video information within the preamplifier from external video to the internally generated OSD video.

Windows

Two separate windows can be opened, utilizing the data stored in the page RAM. Each window has its own horizontal and vertical start position, although the second window should be horizontally spaced at least two character spaces away from the first window, and should never overlap the first window when both windows are on. The OSD window must be placed within the active video.

Character Cell

Each character is defined as a 12 wide by 18 high matrix of picture elements, or 'pixels'. The character font is shown in *Figures 45, 46, 47, 48, 49, 50*. There are two types of characters defined in the character ROM:

1. Two-color: There are 190 two-color characters. Each pixel of these characters is defined by a single bit value. If the bit value is 0, then the color is defined as 'Color 1' or the 'background' color. If the bit value is 1, then the color is defined as 'Color 2', or the 'foreground' color. An example of a character is shown in *Figure 34*.
2. Four-color: There are 64 four-color characters stored in the character ROM. Each pixel of the four-color character is defined by two bits of information, and thus can define four different colors, Color 1, Color 2, Color 3, and Color 4. Color 1 is defined as the 'background' color. All other colors are considered 'foreground' colors, although for most purposes, any of the four colors may be used in any way. Because each four-color character has two bits, the LM1253A internally has a matrix of two planes of ROM as shown in *Figure 35*.

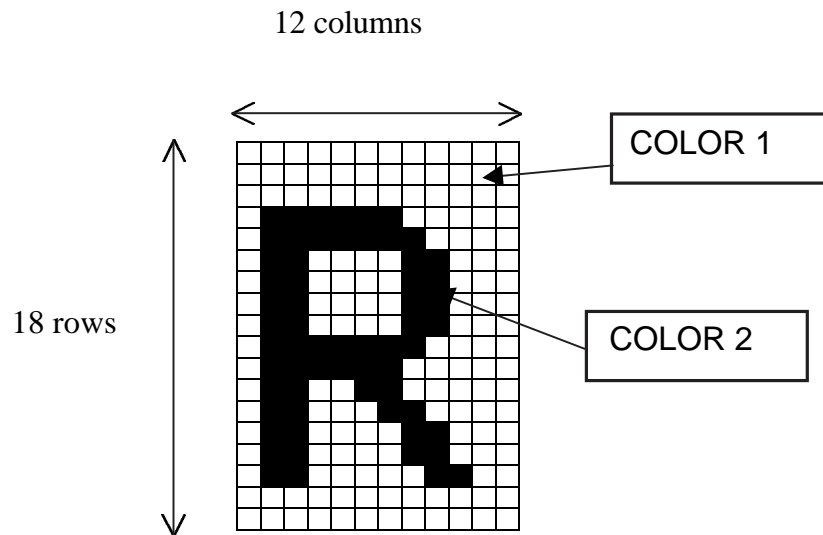

DS101265-38

FIGURE 34. A Two-Color Character

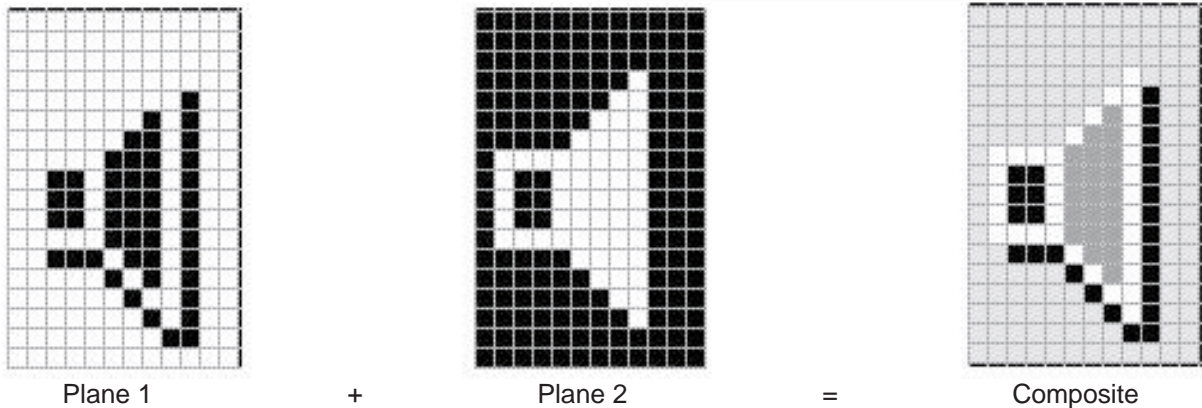

DS101265-39

FIGURE 35. A Four-Color Character

OSD Generator Operation (Continued)

Attribute Tables

Each character has an attribute value assigned to it in the page RAM. The attribute value is 4 bits wide, making each character entry in the page RAM 12 bits wide in total. The attribute value acts as an address which points to one of 16 entries in either the two-color attribute table RAM or the four-color attribute table RAM. The attribute word in the table contains the coding information which defines which color is represented by Color 1 and Color 2 in the two color attribute table and Color 1, Color 2, Color 3, Color 4 in the four-color attribute table. Each color is defined by a 9 bit value, with 3 bits assigned to each channel of RGB. A dynamic look up table defines each of the 16 different color combination selections or 'palettes'. As the look up table can be dynamically coded by the micro-controller over the I²C interface, each color can be assigned to any one of 2⁹ (i.e. 512) choices. This allows a maximum of 64 different colors to be used within one page using the 4-color characters, with up to 4 different colors within any one character and 32 different colors using the 2-color characters, with 2 different colors within any one character.

Transparent Disable

In addition to the 9 lines of video data, a tenth data line is generated by the transparent disable bit. When this line is activated, the black color code will be translated as 'transparent' or invisible. This allows the video information from the PC system to be visible on the screen when this is present. Note that this feature is enabled on all black of the first 8 attribute table entries.

Enhanced Features

In addition to the wide selection of colors for each character, additional character features can be selected on a character by character basis.

1. **Button Boxes**—The OSD generator examines the character string being displayed and if the 'button box' attributes have been set in the Enhanced feature byte, then a box creator selectively substitutes the character pixels in either or both the top and right most pixel line or column with a button box pixel. The shade of the button box pixel depends upon whether a 'depressed' or 'raised' box is required, and can be programmed by I²C. The raised pixel color ('highlight') is defined by the value in the color palette register, EF1 (normally white). The depressed pixel ('lowlight') color by the value in the color palette register EF2 (normally gray). See *Figure 36*.
2. **Heavy Button Boxes**—When heavy button boxes are selected, the color palette value stored in register EF3 is used for the depressed ('lowlight') pixel color instead of the value in register EF2.
3. **Shadowing**—Shadowing can be added to two-color characters by choosing the appropriate attribute value for the character. When a character is shadowed, a shadow pixel is added to the lower right edges of the color 2 image, as shown in *Figure 37*. The color of the shadow is determined by the value in the color palette register EF3 (normally black).
4. **Bordering**—A border can be added to the two-color characters. When a character is bordered, a border pixel is added at every horizontal, vertical or diagonal transition between Color 1 and Color 2. See *Figure 38*. The color of the border is determined by the value in the color palette register EF3 (normally black).
5. **Blinking**—If blinking is enabled as an attribute, all colors within the character except the button box pixels which have been over-written will alternately switch to Color 1 and then back to Color 2 at a rate determined by the micro-controller under I²C control.

OSD Generator Operation (Continued)

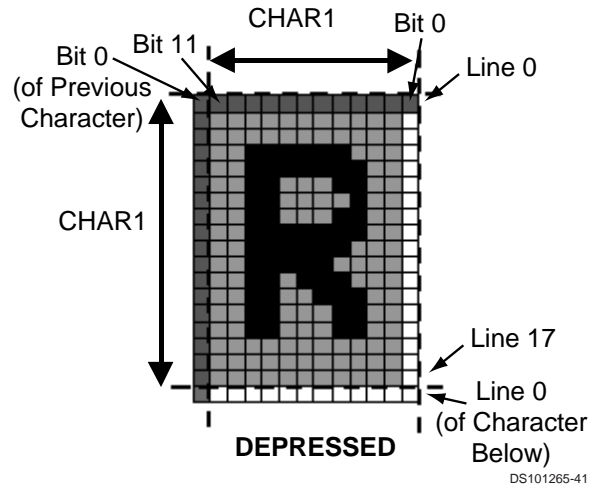
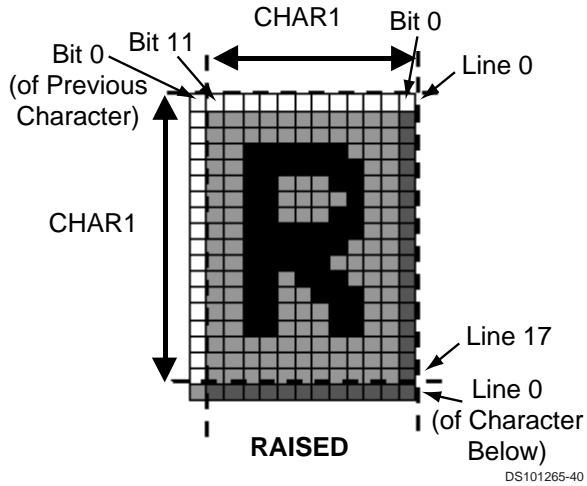

Effect on the screen:

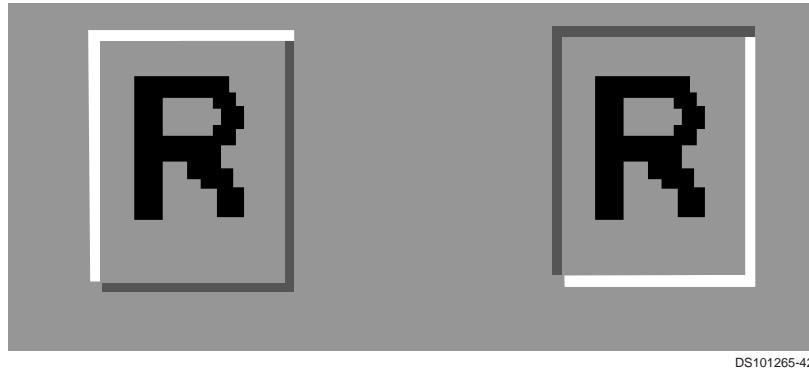

FIGURE 36. Button Boxes

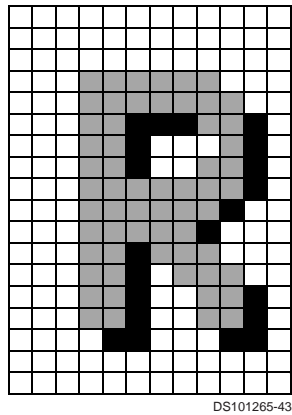

FIGURE 37. Shadowing

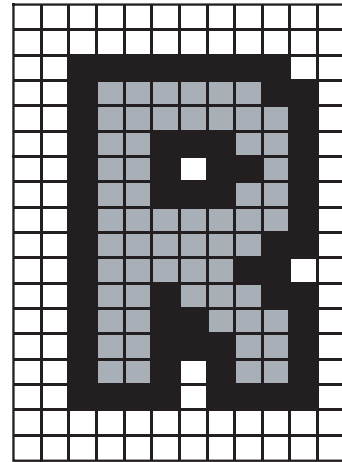

FIGURE 38. Bordering

Micro-Controller Interface

The micro-controller interfaces to the LM1253A pre-amp via an I²C interface. The protocol of the interface begins with a Start Pulse followed by a byte comprised of a seven bit Slave Device Address and a Read/Write bit. Since the first byte is composed of both the address and the read/write bit the address of the LM1253A for writing is BAh (1011 1010) and the address for reading is BBh (1011 1011). The development software provided by National Semiconductor will automatically take care of the difference between the read and write addresses if the target address under the communications tab is set to BAh. *Figures 39, 40* show a write and read sequence across the I²C interface.

Write Sequence

The write sequence begins with a start condition which consists of the master pulling SDA low while SCL is held high. The slave device address is next sent. The address

byte is made up of an address of seven bits (7-1) and the read/write bit (0). Bit 0 is low to indicate a write operation. Each byte that is sent is followed by an acknowledge. When SCL is high the master will release the SDA line. The slave must pull SDA low to acknowledge. The register to be written to is next sent in two bytes, the least significant byte being sent first. The master can then send the data, which consists of one or more bytes. Each data byte is followed by an acknowledge bit. If more than one data byte is sent the data will increment to the next address location. See *Figure 39*.

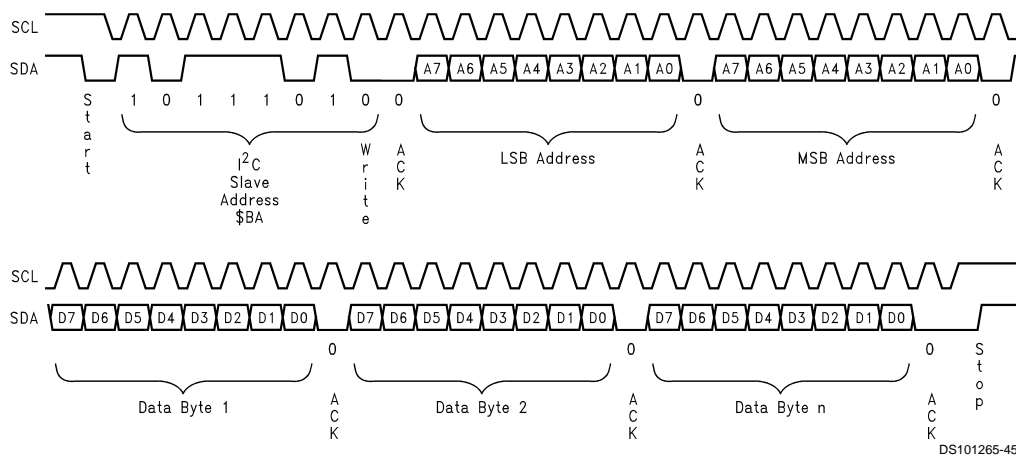
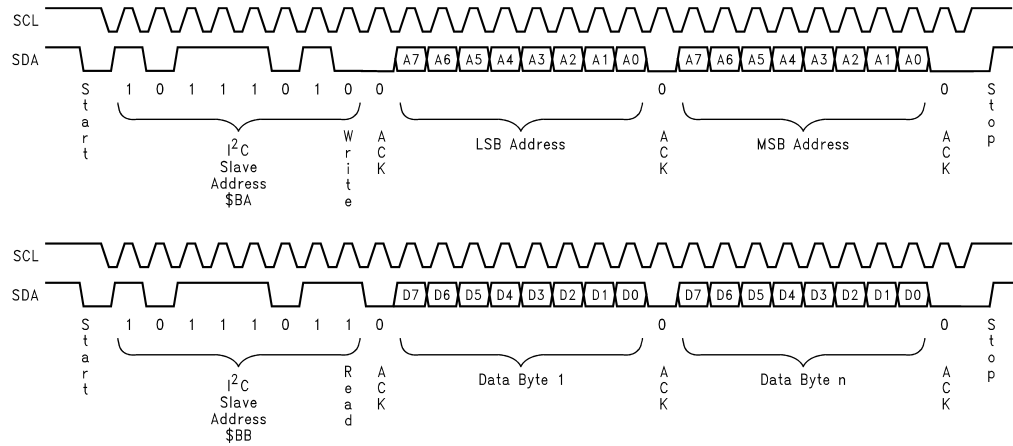

FIGURE 39. I²C Write Sequence

Read Sequence

Read sequences are comprised of two I²C transfer sequences: The first is a write sequence that only transfers the two byte address to be accessed. The second is a read sequence that starts at the address transferred in the previous address only write access and increments to the next address upon every data byte read. This is shown in *Figure 40*.

Micro-Controller Interface (Continued)



DS101265-46

FIGURE 40. I²C Read Sequence

The write sequence consists of the Start Pulse, the Slave Device Address, the Read/Write bit (a zero, indicating a write) and the Acknowledge bit; the next byte is the least significant byte of the address to be accessed, followed by its Acknowledge bit. This is then followed by a byte containing the most significant address byte, followed by its Acknowledge bit. Then a Stop bit indicates the end of the address only write access.

Next the read data access will be performed beginning with the Start Pulse, the Slave Device Address, the Read/Write bit (a one, indicating a read) and the Acknowledge bit. The next 8 bits will be the read data driven out by the LM1253A pre-amp associated with the address indicated by the two address bytes. Subsequent read data bytes will correspond to the next increment address locations.

Read data from the LM1253A only when both OSD windows are disabled.

LM1253A Address Map

TABLE 3. Character ROM Address Map

Address Range	R/W	Description
CHARACTER ROM		
0000h–2FFFh	R	<p>ROM Character Fonts, 190 two-color Character Fonts that are read-only.</p> <p>The format of the address is as follows:</p> <p>A15–A14: Always zeros.</p> <p>A13–A6: Character value (00h–BFh are valid values)</p> <p>A5–A1: Row of the character (00h–11h are valid values)</p> <p>A0: Low byte of line when a zero. High byte of line when a one.</p> <p>The low byte will contain the first eight pixels of the line with data Bit 0 corresponding to the left most bit in the Character Font line. The high byte will contain the last four pixels and data Bits 7–4 are “don’t cares”. Data Bit 3 of the high byte corresponds to the right most pixel in the Character Font line.</p>
3000h–3FFFh	R	<p>ROM Character Fonts, 64 four-color Character Fonts that are read-only.</p> <p>The format of the address is as follows:</p> <p>A15–A14: Always zeros.</p> <p>A13–A6: Character value (C0h–FFh are valid values)</p> <p>A5–A1: Row of the character (00h–11h are valid values)</p> <p>A0: Low byte of line when a zero. High byte of line when a one.</p> <p>The low byte will contain the first eight pixels of the line with data Bit 0 corresponding to the left most bit in the Character Font line. The high byte will contain the last four pixels and data Bits 7–4 are “don’t cares”. Data Bit 3 of the high byte corresponds to the right most pixel in the Character Font line.</p> <p>NOTE: The value of Bit 0 of the Character Font Access Control Register (I²C Address 8402h) is a zero, it indicates that the Bit 0 data value of the four-color pixels is being accessed via these addresses. When the value of Bit 0 of the Access Control Register is a one, it indicates that the Bit 1 data value of the four-color pixel is being accessed via these addresses.</p>
4000h–7FFFh		RESERVED.

TABLE 4. Display Page RAM Address Map

Address Range	R/W	Description
DISPLAY PAGE RAM		
8000h–81FF	R/W	<p>Display Page RAM Characters. A total of 512 display characters, skipped line, end-of-row and end-of-window character codes may be supported via this range.</p> <p>To support skipped lines and character attributes a number of special case rules are used when writing to this range. (Refer to the <i>Display Page RAM</i> section of this document for more details.)</p>

Pre-Amp Interface Registers

TABLE 5. OSD Interface Registers

LM1253A OSD Interface Registers										
Register	Address	Default	D7	D6	D5	D4	D3	D2	D1	D0
Fonts-2 Color	0000–2FFE		PIXEL[7:0]							
	+1		X	X	X	X	PIXEL[11:8]			
Fonts-4 Color	3000–3FFE		PIXEL[7:0]							
	+1		X	X	X	X	PIXEL[11:8]			
Display Page	8000–83FF		CHAR_CODE[7:4] or reserved				CHAR_CODE[3:0] or ATTR_CODE			
FRMCTRL1	8400	10h	X	X	X	TD	CDPR	D2E	D1E	OSE
FRMCTRL2	8401	80h	PIXELS_PER_LINE[2:0]			BLINK_PERIOD[4:0]				
CHARFONTACC	8402	00h	X	X	X	X	X	X	ATTR	FONT4
VBLANKDUR	8403	10h	X	VBLANK_DURATION[6:0]						
CHARHTCTRL	8404	51h	CHAR_HEIGHT[7:0]							
BBHLCTRLB0	8405	FFh	B[1:0]		G[2:0]			R[2:0]		
BBHLCTRLB1	8406	01h	X	X	X	X	X	X	X	B[2]
BBLLCTRLB0	8407	00h	B[1:0]		G[2:0]			R[2:0]		
BBLLCTRLB1	8408	00h	X	X	X	X	X	X	X	B[2]
CHSDWCTRLB0	8409	00h	B[1:0]		G[2:0]			R[2:0]		
CHSDWCTRLB1	840A	00h	X	X	X	X	X	X	X	B[2]
ROMSIGCTRL	840D	00h	X	X	X	X	X	X	X	CRS
ROMSIGDATAB0	840E	00h	CRC[7:0]							
ROMSIGDATAB1	840F	00h	CRC[15:8]							
HSTR1	8410	13h	HPOS[7:0]							
VSTR1	8411	14h	VPOS[7:0]							
COLWIDTH1B0	8414	00h	COL[7:0]							
COLWIDTH1B1	8415	00h	COL[15:8]							
COLWIDTH1B2	8416	00h	COL[23:16]							
COLWIDTH1B3	8417	00h	COL[31:24]							
HSTR2	8418	56h	HPOS[7:0]							
VSTR2	8419	5Bh	VPOS[7:0]							
W2STRADRL	841A	00h	ADDR[7:0]							
W2STRADRH	841B	01h	X	X	X	X	X	X	X	ADDR[8]
COLWIDTH2B0	841C	00h	COL[7:0]							
COLWIDTH2B1	841D	00h	COL[15:8]							
COLWIDTH2B2	841E	00h	COL[23:16]							
COLWIDTH2B3	841F	00h	COL[31:24]							

Note: Set Reserved bits to 0.

Pre-Amp Interface Registers (Continued)

TABLE 6. Pre-Amp Interface Registers

LM1253A Pre-Amp Interface Registers										
Register	Address	Default	D7	D6	D5	D4	D3	D2	D1	D0
BGAINCTRL	8430	60h	X							BGAIN[6:0]
GGAINCTRL	8431	60h	X							GGAIN[6:0]
RGAINCTRL	8432	60h	X							RGAIN[6:0]
CONTRCTRL	8433	60h	X							CONTRAST[6:0]
BBIASCTRL	8434	80h								BBIAS[7:0]
GBIASCTRL	8435	80h								GBIAS[7:0]
RBIASCTRL	8436	80h								RBIAS[7:0]
BRIGHTCTRL	8437	80h								BRIGHTNESS[7:0]
DCOFFSET	8438	94h								PEDESTAL[2:0] OSD CONT[1:0] DC OFFSET[2:0]
GLOBALCTRL	8439	00h	X	X	X	X	X	X	PS	BV
PLLREQRNG	843E	16h	X	X	X	X			IVISTAT[1:0]	PFR[1:0]
SRTSTCTRL	843F	00h	X	AID	X	X	X	X	X	SRST

Note: Set Reserved bits to 0.

Two-Color Attribute Table

TABLE 7. Two-Color Attribute Registers

LM1253A Two-Color Attribute Registers									
Register	Address	D7	D6	D5	D4	D3	D2	D1	D0
ATT2C0n	8440 + (n*4)	C1B[1:0]		C1G[2:0]			C1R[2:0]		
ATT2C1n	+1	C2B[0]	C2G[2:0]			C2R[2:0]			C1B[2]
ATT2C2n	+2	X	X	EF[3:0]			C2B[2:1]		
ATT2C3n	+3	X	X	X	X	X	X	X	X

Note: Set Reserved bits to 0.

Two-color display character Attribute Table. The attributes for two-color display characters may be written or read via the following address format:

A15–A6: Always 1000_0100_01b.

A5–A2: Attribute code (0h–Fh are valid values), n

A1–A0: Determines which of the 3 bytes is to be accessed.

NOTE: In the table, n indicates the attribute number $0 \leq n \leq 15$

NOTE: When writing, bytes 0 through 2 must be written, in that order. Bytes 0 through 2 will take effect after byte 2 is written.

Since byte 3 contains all reserved bits, this byte may be written, but no effect will result.

When reading, it is OK to read only one, two, or all three bytes.

If writing more than one 2-color attributes using the auto increment feature, all four bytes must be written.

Four-Color Attribute Table

TABLE 8. Four-Color Attribute Registers

LM1253A Four-Color Attribute Registers									
Register	Address	D7	D6	D5	D4	D3	D2	D1	D0
ATT4C0n	8500 + (n*8)	C1B[1:0]		C1G[2:0]			C1R[2:0]		
ATT4C1n	+1	C2B[0]	C2G[2:0]			C2R[2:0]			C1B[2]
ATT4C2n	+2	X	X	EF[3:0]			C2B[2:1]		

Four-Color Attribute Table (Continued)

TABLE 8. Four-Color Attribute Registers (Continued)

LM1253A Four-Color Attribute Registers									
Register	Address	D7	D6	D5	D4	D3	D2	D1	D0
ATT4C3n	+3	X	X	X	X	X	X	X	X
ATT4C4n	+4	C3B[1:0]		C3G[2:0]			C3R[2:0]		
ATT4C5n	+5	C4B[0]	C4G[2:0]			C4R[2:0]			C3B[2]
ATT4C6n	+6	X	X	X	X	X	X	C4B[2:1]	
ATT4C7n	+7	X	X	X	X	X	X	X	X

Note: Set Reserved bits to 0.

Four-color display character Attribute Table. The attributes for four-color display characters may be written or read via the following address format:

A15–A7: Always 1000_0101_0b

A6–A3: Attribute value (0h–Fh are valid values), n

A2–A0: Determine which of the six bytes of the attribute is to be accessed.

NOTE: In the table, n indicates the attribute number, $0 \leq n \leq 15$

NOTE: When writing, bytes 0 to 2 must be written, in that order and bytes 4 to 6 must be written, in that order.

Bytes 0 through 2 will take effect after byte 2 is written. Bytes 4 through 6 will take effect after byte 6 is written.

Since bytes 5 and 7 contain all reserved bits, these bytes may be written, but no effect will result. When reading, it is OK to read only one, two, or all three bytes.

If writing more than one 4-color attributes using the auto increment feature, all eight bytes must be written.

Display Page RAM

The OSD Window

The Display Page RAM contains all of the 8 bit display character codes and their associated 4 bit attribute codes, and the special 12 bit page control codes—the row-end, skip-line parameters and window-end characters.

The LM1253A has a distinct advantage over many OSD generators that it allows variable size and format windows. The window size is not dictated by a fixed geometry area of RAM. Instead, 512 locations of 12 bit words are allocated in RAM for the definition of the windows, with special control codes to define the window size and shape.

Window width can be any length supported by the number of pixels per line that is selected divided by the number of pixels in a character line. It must be remembered that OSD characters displayed during the monitor blanking time will not be displayed on the screen, so the practical limit to the number of horizontal characters on a line is reduced by the number of characters within the horizontal blanking period.

Character Code And Attribute Code

Each of the 512 x 12 bit locations in the page RAM is comprised of an 8 bit character or control code, and a 4 bit attribute code:

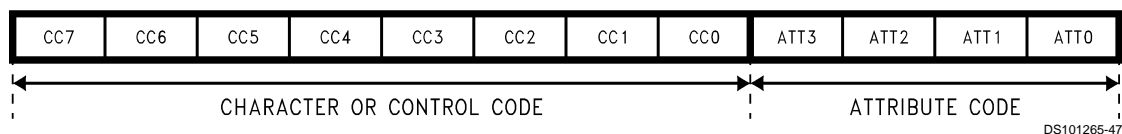

DS101265-47

Bits 11–4 Character Code: These 8 bits define which of the 254 characters is to be called from the character ROM. Valid character codes are 02h–FFh.

Bits 3–0: Attribute code. These 4 bits address the attribute table used to specify which of the 16 locations in RAM specify the colors and enhanced features to be used for this particular character. Two separate attribute tables are used, one for 2-color characters, the other for 4-color characters.

Each of the characters are stored in sequence in the page RAM. Special codes are used between lines to show where one line ends and the next begins, and also to allow blank (or 'skipped') lines to be added between character rows.

Display Page RAM (Continued)

Row End Code

To signify the end of a row of characters, a special 'Row-End' (RE) code is used in place of a character code.

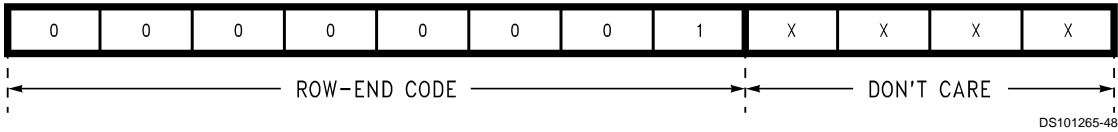

Bits 11–4 Row-End Code: A special character code of 01h

Bits 3–0: Don't care

The RE character tells the OSD generator that the character codes following must be placed on a new row in the displayed window.

Skipped Line Parameters

Each displayed row of characters may have up to 15 skipped (i.e., blank) lines beneath it in order to allow finer control of the vertical spacing of character rows. (Each skipped line is treated as a single auto-height character pixel line, so multiple scan lines may actually be displayed in order to maintain accurate size relative to the character cell—see section *Constant Character Height Mechanism*).

To specify the number of skipped lines, the first character in each new row of characters to be displayed is interpreted differently than the other characters in the row. Instead of interpreting the data in the location as a character code, the information of the 12 bit word is defined as follows:



Bits 11–8 Reserved.

Bits 7–4: Skipped Lines. These four bits determine how many blank pixel lines will be inserted between the present row of display characters and the next row of display characters. A range of 0–15 may be selected.

Bits 3–0: Attribute code. The pixels in the skipped lines will normally be Color 1 of the addressed 2-Color Attribute Table entry. Note that the pixels in the first line immediately below the character may be overwritten by the pixel override system that creates the button box. (Refer to the *Button Box Formation* Section for more information.)

Each new line MUST start with an SL code, even if the number of skipped lines to follow is zero. An SL code MUST always follow an RE control code.

An RE code may follow an SL code if several 'transparent' lines are required between sections of the window (see example 3 below). In this case, skipped lines of zero characters are displayed, causing a break in the window.

Window-End Code

To signify the end of the window, a special 'Window-End' (WE) code is used in place of a Row-End code.

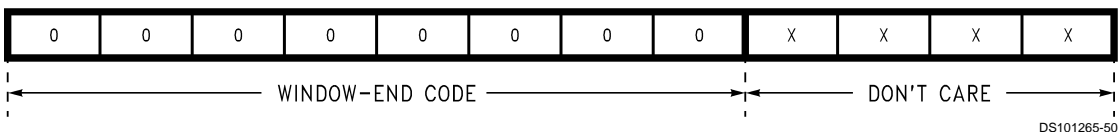

Bits 11–4 Window-End Code: A special character code of 00h

Bits 3–0: Don't care

The WE control code tells the OSD generator that the character codes following belong to another displayed window at the next window location. A WE control code may follow normal characters or an SL parameter, but never an RE control code.

Writing To The Page RAM

The Display Page RAM can contain up to 512 of the above listed characters and control codes. Each character, or control code will consume one of the possible 512 locations. For convenience, a single write instruction to bit 3 of the Frame Control Register (8400h) can reset the page RAM value to all zero.

Display Window 1 will also start at the first location (corresponding to the I²C address 8000h). This location must always contain the Skip-Line (SL) parameters associated with the first row of Display Window 1. Subsequent locations should contain the characters to be displayed on row 1 of Display Window 1, until the RE character code or WE character code is written into the Display Page-RAM.

Display Page RAM (Continued)

The skip-line parameters associated with the next row must always be written to the location immediately after the preceding row's row-end character. The only exception to this rule is when a window-end character (value 00h) is encountered. It is important to note that a row-end character should not precede a window-end character (otherwise the window-end character will be interpreted as the next row's skip-line parameters). Instead, the window-end character will both end the row and the window making it unnecessary to precede it with a row-end character.

The I²C Format for writing a sequence of display characters is minimized by allowing sequential characters with the same attribute code to be sent in a string as follows:

Byte #1—I²C Slave Address

Byte #2—LSB Address

Byte #3—MSB Address

Byte #4—Attribute Table Entry to use for the following characters

Byte #5—First display character, SL parameter, RE or WE control code.

Byte #6—Second display character, SL parameter, RE or WE control code.

Byte #7—Third display character, SL parameter, RE or WE control code.

.

.

Byte #n—Last display character in this color sequence, SL parameter, RE or WE control code to use the associated Attribute Table Entry.

The Attribute Table Entry (Byte #4, of the above) is automatically associated with each subsequent display character or SL code written. The following are examples of how the Display Page RAM associates to the actual On-Screen Display Window #1.

EXAMPLE #1:

A 3 X 3 character matrix of white characters on a black background is to be displayed using 2-color character codes:

The actual On-Screen Display of Window #1 is shown in *Figure 41*. Note the dotted white lines are not shown on the monitor. They are shown here to show where the character ends.



DS101265-51

FIGURE 41. Example 1 OSD

Notes:

- Every row must begin with an attribute and a SL. Display Page RAM memory location 8000h will always be associated with the SL of row 0 of Display Window #1.
- Every row except the last row of a Display Window must end with an RE character. The character immediately after an RE character is always the SL value for the next row.
- The last row in a Display Window must be a WE character. The WE character must NOT be preceded by an RE character.
- The entire Display Window may be written in a single I²C write sequence because the Attribute Table entry (i.e., the color palette) does not change for the entire Display Window.
- The Attribute Table Entry that is associated with RE and WE characters are "don't cares". In general it is most efficient just to allow them to be the same value as the Attribute Table Entry associated with the previous display character.
- The colors of the characters and background can be stored in a single location in the 2-color attribute table, in location ATT0.
- The data shown in *Table 9* is sent to the LM1253A in one I²C transmission.

Display Page RAM (Continued)

TABLE 9. Example 1 I²C Transmission

Command Sent (hex)	Description	RAM Address of the Character or Command
	I ² C start condition (See the <i>Micro-Controller Interface Section</i>)	
BA	Chip address (See the <i>Micro-Controller Interface Section</i>)	
00	Address LSB	
80	Address MSB	
00	Use Attribute table 00 for the following characters	
00	Skip 0 lines	8000
02	Character "A"	8001
03	Character "B"	8002
04	Character "C"	8003
01	Row end	8004
00	Skip 0 lines	8005
05	Character "D"	8006
06	Character "E"	8007
07	Character "F"	8008
01	Row end	8009
00	Skip 0 lines	800A
08	Character "G"	800B
09	Character "H"	800C
0A	Character "I"	800D
00	Window end	800E
	I ² C stop condition (See the <i>Micro-Controller Interface Section</i>)	

EXAMPLE #2:

A 3X3 character matrix of characters on a black background is to be displayed on the screen, using 2-color character codes. 2 skipped lines are required below the first line of characters, 3 skipped lines are required below the second line of characters, and 4 skipped lines are required below the third line of characters. The first line of characters will use color attribute 0, the second line will use color attribute 1, the third line will use color attribute 0 for the first character, color attribute 1 for the second character, and color attribute 2 for the third character. This is shown in *Figure 42*.

Display Page RAM (Continued)

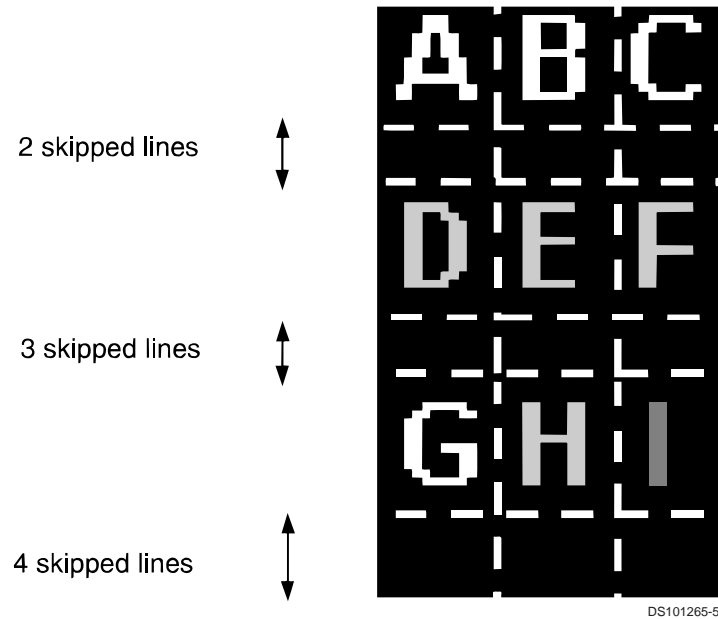

DS101265-52

FIGURE 42. Example 2 OSD

Notes:

- Every row must begin with an attribute and a SL value. Display Page RAM memory location 8000h will always be associated with the SL of row 0 of Display Window #1.
- If an I²C transmission finishes without an RE (in the middle of a row) the first byte sent in the next I²C transmission is the attribute.
- Every row except the last row of a Display Window must end with an RE character. The character immediately after an RE character is always the SL value for the next row.
- The last row in a Display Window must be a WE character. The WE character must NOT be preceded by an RE character.
- The data shown in *Table 10* is sent to the LM1253A in five I²C transmissions.

TABLE 10. Example 2 I²C Transmissions

Command Sent (hex)	Description	RAM Address of the Character or Command
	I ² C start condition (See the <i>Micro-Controller Interface</i> Section)	
BA	Chip address (See the <i>Micro-Controller Interface</i> Section)	
00	Address LSB	
80	Address MSB	
00	Use Attribute table 00 for the following characters	
02	Skip 2 lines	8000
02	Character "A"	8001
03	Character "B"	8002
04	Character "C"	8003
01	Row end	8004
	I ² C stop condition (See the <i>Micro-Controller Interface</i> Section)	
	I ² C start condition (See the <i>Micro-Controller Interface</i> Section)	
BA	Chip address (See the <i>Micro-Controller Interface</i> Section)	
05	Address LSB	
80	Address MSB	

Display Page RAM (Continued)

TABLE 10. Example 2 I²C Transmissions (Continued)

Command Sent (hex)	Description	RAM Address of the Character or Command
01	Use Attribute table 01 for the following characters	
03	Skip 3 lines	8005
05	Character "D"	8006
06	Character "E"	8007
07	Character "F"	8008
01	Row end	8009
	I ² C stop condition (See the <i>Micro-Controller Interface Section</i>)	
	I ² C start condition (See the <i>Micro-Controller Interface Section</i>)	
BA	Chip address (See the <i>Micro-Controller Interface Section</i>)	
0A	Address LSB	
80	Address MSB	
00	Use Attribute table 00 for the following characters	
04	Skip 4 lines	800A
08	Character "G"	800B
	I ² C stop condition (See the <i>Micro-Controller Interface Section</i>)	
	I ² C start condition (See the <i>Micro-Controller Interface Section</i>)	
BA	Chip Address	
0C	Address LSB	
80	Address MSB	
01	Use Attribute table 01 for the following characters	
09	Character "H"	800C
	I ² C stop condition (See the <i>Micro-Controller Interface Section</i>)	
	I ² C start condition (See the <i>Micro-Controller Interface Section</i>)	
BA	Chip address (See the <i>Micro-Controller Interface Section</i>)	
0D	Address LSB	
80	Address MSB	
02	Use Attribute table 02 for the following characters	
0A	Character "I"	800D
00	Window end	800E
	I ² C stop condition (See the <i>Micro-Controller Interface Section</i>)	

EXAMPLE #3:

Two different length rows of characters with a black background are to be displayed on the screen, using 2-color character codes. 3 transparent skipped lines are required between the character rows. This is shown in *Figure 43*.

Display Page RAM (Continued)

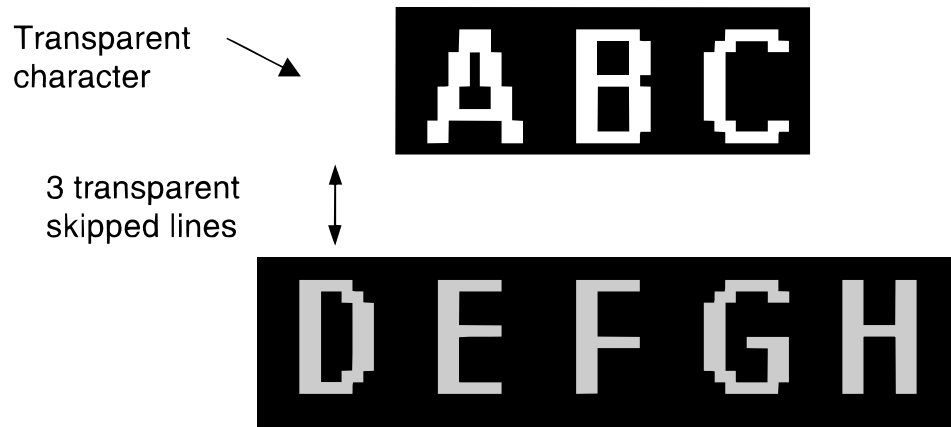

DS101265-53

FIGURE 43. Example 3 OSD

Notes:

- In order to centralize the three characters above the five characters on the row below, a 'transparent' blank character has been used as the first character on the row.
- In order to create the transparent skipped lines between the two character rows, a row of no characters has been used, resulting in an RE, SL, RE, SL control code sequence.
- In this example, the transparent character is defined by the 2-color attribute table entry ATT0. Bit 4 of Frame Control Register 1 must be set to indicate that the black color is to be translated as transparent (see *Control Register Definitions* section). Setting the transparent bit will make any black in ATT0–ATT7 transparent.
- The top row of characters are white on black; in this example, these are defined by the 2-color attribute table entry ATT9.
- The second row of characters are gray on black; in this example, these are defined by the 2-color attribute table entry ATT10.
- The black background of the characters are not transparent because ATT9 and ATT10 are used.
- The data shown in *Table 11* is sent to the LM1253A in four I²C transmissions.

Display Page RAM (Continued)

TABLE 11. Example 3 I²C Transmissions

Command Sent (hex)	Description	RAM Address of the Character or Command
	I ² C start condition (See the <i>Micro-Controller Interface Section</i>)	
BA	Chip address (See the <i>Micro-Controller Interface Section</i>)	
00	Address LSB	
80	Address MSB	
00	Use Attribute table 00 for the following characters	
00	Skip 0 lines	8000
80	Character “ ”	8001
	I ² C stop condition (See the <i>Micro-Controller Interface Section</i>)	
	I ² C start condition (See the <i>Micro-Controller Interface Section</i>)	
BA	Chip address (See the <i>Micro-Controller Interface Section</i>)	
02	Address LSB	
80	Address MSB	
09	Use Attribute table 09 for the following characters	
02	Character “A”	8002
03	Character “B”	8003
04	Character “C”	8004
01	Row end	8005
	I ² C stop condition (See the <i>Micro-Controller Interface Section</i>)	
	I ² C start condition (See the <i>Micro-Controller Interface Section</i>)	
BA	Chip address (See the <i>Micro-Controller Interface Section</i>)	
06	Address LSB	
80	Address MSB	
00	Use Attribute table 00 for the following characters	
03	Skip 3 lines	8006
01	Row end	8007
	I ² C stop condition (See the <i>Micro-Controller Interface Section</i>)	
	I ² C start condition (See the <i>Micro-Controller Interface Section</i>)	
BA	Chip address (See the <i>Micro-Controller Interface Section</i>)	
08	Address LSB	
80	Address MSB	
0A	Use Attribute table 0A for the following characters	
00	Skip 0 lines	8008
05	Character “D”	8009
06	Character “E”	800A
07	Character “F”	800B
08	Character “G”	800C
09	Character “H”	800D
00	Window end	800E
	I ² C stop condition (See the <i>Micro-Controller Interface Section</i>)	

Control Register Definitions

OSD INTERFACE REGISTERS

Frame Control Register 1 (I²C address 8400h).

REGISTER NAME: FRMCTRL1

Bit 7 Bit 0

RSV	RSV	RSV	TD	CDPR	D2E	D1E	OsE
-----	-----	-----	----	------	-----	-----	-----

- Bit 0: On-Screen Display Enable. The On-Screen Display will be disabled when this bit is a zero. When this bit is a one the On-Screen Display will be enabled and Display Window 1 will be enabled if Bit 1 of this register is a one; likewise Display Window 2 will be enabled if Bit 2 of this register is a one.
- Bit 1: Display Window 1 Enable. When Bit 0 of this register and this bit are both ones, Display Window 1 is enabled. If either bit is a zero, then Display Window 1 will be disabled.
- Bit 2: Display Window 2 Enable. When Bit 0 of this register and this bit are both ones, Display Window 2 is enabled. If either bit is a zero, then Display Window 2 will be disabled.
- Bit 3: Clear Display Page RAM. Writing a one to this bit will result in setting all of the Display Page RAM values to zero. This bit is automatically cleared after the operation is complete.
- Bit 4: Transparent Disable. When this bit is a zero, a palette color of black (ie color palette look-up table value of '000 000 000') in the first 8 palette look-up table address locations (i.e., ATT = 0h–7h) will be translated as transparent. When this bit is a one, the color will be translated as black.
- Bits 7–4: RESERVED.

Frame Control Register 2 (I²C address 8401h).

REGISTER NAME: FRMCTRL2

Bit 7 Bit 0

PL2	PL1	PL0	BP4	BP3	BP2	BP1	BP0
-----	-----	-----	-----	-----	-----	-----	-----

- Bits 4–0: Blinking Period. These five bits set the blinking period of the blinking feature, which is determined by multiplying the value of these bits by 8, and then multiplying the result by the vertical field rate.
- Bits 7–5: Pixels per Line. These three bits determine the number of pixels per line.

Bits 7–5	Description	Max Fh
000b	512 pixels per line	125 kHz
001b	576 pixels per line	119 kHz
010b	640 pixels per line	112 kHz
011b	704 pixels per line	106 kHz
100b	768 pixels per line	100 kHz
101b	832 pixels per line	93 kHz
110b	896 pixels per line	87 kHz
111b	960 pixels per line	81 kHz

Character Font Access Control Register (I²C address 8402h).

REGISTER NAME: CHARFONTACC

Bit 7 Bit 0

RSV	RSV	RSV	RSV	RSV	RSV	C/A	Bit
-----	-----	-----	-----	-----	-----	-----	-----

- Bit 0: Four-color pixel data value Bit indicator. This bit indicates if Bit 0 (when a zero) or Bit 1 (when a one) of the four-color pixel data value is being accessed via I²C addresses 3000h–3FFFh.
- Bit 1: Character/Attribute Code Indicator. This bit controls what value is read via I²C reads of the Display Page RAM (address range 8000h–81FFh). When this bit is a 0, such reads will return the character code. When this bit is a 1, the attribute code will be returned.
- Bits 7–2: RESERVED.

Control Register Definitions (Continued)

Vertical Blank Duration Control Register (I²C address 8403h).

REGISTER NAME: VBLANKDUR

Bit 7								Bit 0
	RSV	VB6	VB5	VB4	VB3	VB2	VB1	VB0

Bits 6–0: Vertical Blank Duration. These seven bits set the duration of the VBLANK signal in numbers of horizontal scan lines.

Bit 7: RESERVED.

OSD Character Height Control Register (I²C address 8404h).

REGISTER NAME: CHARHTCTRL

Bit 7								Bit 0
	CH7	CH6	CH5	CH4	CH3	CH2	CH1	CH0

Bits 7–0: Character Height: this register sets the character height according to the constant character height mechanism described in section Constant Character Height Mechanism. The value programmed in the register is equal to the approximate number of OSD height compensated lines required on the screen divided by 4. The value is only approximate, due to the approximation used in scaling the characters.

Example: If approximately 384 OSD lines are required on the screen (regardless of the number of image lines) then the Character Height Control Register is programmed with the value of 81.

Button Box Highlight Color Register (EF1) (I²C address 8405h–8406h).

REGISTER NAME: BBHLCTRLB1 (8406h) BBHLCTRLB0 (8405h)

Bit 15								Bit 8	Bit 7					Bit 0		
	RSV	RSV	RSV	RSV	RSV	RSV	RSV	R2	R1	R0	B2	B1	B0	G2	G1	G0

Bits 8–0: Button Box highlight color. This register indicates the value of Enhanced Feature (button box highlight) register EF1.

Bits 15–9: RESERVED.

Button Box Lowlight Color Register (EF2) (I²C address 8407h–8408h).

REGISTER NAME: BBLCTRLB1 (8408h) BBLCTRLB0 (8407h)

Bit 15								Bit 8	Bit 7					Bit 0		
	RSV	RSV	RSV	RSV	RSV	RSV	RSV	R2	R1	R0	B2	B1	B0	G2	G1	G0

Bits 8–0: Button Box lowlight color. This register indicates the value of Enhanced Feature (button box lowlight) register EF2.

Bits 15–9: RESERVED.

Heavy Button Box Lowlight/Shadow/Shading Color Register (EF3) (I²C address 8409h–840Ah).

REGISTER NAME: CHSDWCTRLB1 (840Ah) CHSDWCTRLB0 (8409h)

Bit 15								Bit 8	Bit 7					Bit 0		
	RSV	RSV	RSV	RSV	RSV	RSV	RSV	R2	R1	R0	B2	B1	B0	G2	G1	G0

Bits 8–0: Heavy Button Box lowlight/shadow color. This register indicates the value of Enhanced Feature (heavy button box lowlight or shadow/shading) register EF3.

Bits 15–9: RESERVED.

Control Register Definitions (Continued)

ROM Signature Control Register (I²C address 840Dh).

REGISTER NAME: ROMSIGCTRL

Bit 7	Bit 0							
RSV	RSV	RSV	RSV	RSV	RSV	RSV	RSV	CRS

Bit 0: Calculate ROM Signature. Setting this bit causes the entire ROM to be read, sequentially, and a 16 bit CRC calculated over its contents. The residual value from this calculation is placed in the ROM Signature Data register. This bit automatically clears itself when the calculation has been completed.

Bits 7–1: RESERVED.

ROM Signature Data Register (I²C address 840Eh–840Fh).

REGISTER NAME: ROMSIGDATAB1 (840Fh) ROMSIGDATAB0 (840Eh)

Bit 15	Bit 8	Bit 7	Bit 0												
CRC15	CRC14	CRC13	CRC12	CRC11	CRC10	CRC9	CRC8	CRC7	CRC6	CRC5	CRC4	CRC3	CRC2	CRC1	CRC0

Bits 15–0: ROM Signature Data. This register indicates the residual value from the CRC calculation. Devices containing ROMs with different programming will give different signatures. Devices with the same ROM programming will give the same signature.

Display Window 1 Horizontal Pixel Start Location Register (I²C address 8410h).

REGISTER NAME: HSTRT1 (8410h)

Bit 7	Bit 0						
1H7	1H6	1H5	1H4	1H3	1H2	1H1	1H0

Bits 7–0: Display Window 1 Horizontal Pixel Start Location. These seven bits determine the starting horizontal pixel location, which is determined by multiplying the value of these bits by 4 and adding 30 pixels. Due to pipeline delays, the first usable location for the OSD window is approx 42 pixels to the right of the horizontal flyback pulse. For this reason, the display start location must be programmed with a number larger than 2, otherwise improper operation may occur. This byte must be set so the entire OSD window is within the active video.

Display Window 1 Vertical Pixel Start Location Register (I²C address 8411h).

REGISTER NAME: VSTRT1 (8411h)

Bit 7	Bit 0						
1V7	1V6	1V5	1V4	1V3	1V2	1V1	1V0

Bits 7–0: Display Window 1 Vertical Pixel Start Location. These eight bits determine the starting vertical pixel location in constant height character lines, which is determined by multiplying the value of these bits by 2. (Note, each character line is treated as a single auto-height character pixel line, so multiple scan lines may actually be displayed in order to maintain accurate position relative to the character cell size—See *Constant Character Height Mechanism* section.) This byte must be set so the entire OSD window is within the active video.

Display Window 1 Column Width Control Register (I²C address 8414h–8417h).

REGISTER NAME: COLWIDTH1B3 (8417h) COLWIDTH1B2 (8416h) COLWIDTH1B1 (8415h) COLWIDTH1B0 (8414h)

Bit 31	Bit 24	Bit 23	Bit 16												
COL31	COL30	COL29	COL28	COL27	COL26	COL25	COL24	COL23	COL22	COL21	COL20	COL19	COL18	COL17	COL16
Bit 15	Bit 8	Bit 7	Bit 0												
COL15	COL14	COL13	COL12	COL11	COL10	COL9	COL8	COL7	COL6	COL5	COL4	COL3	COL2	COL1	COL0

Bits 31–0: Display Window 1 Column Width 2x Enable Bits. These thirty-two bits correspond to columns 31–0 of Display Window 1, respectively. A value of zero indicates the column will have normal width (12 pixels). A value of one indicates the column will be twice as wide as normal (24 pixels). For the double wide case, each Character Font pixel location will be displayed twice, in two consecutive horizontal pixel locations.

The user should note that if more than 32 display characters are programmed to reside on a row, then all display characters after the first thirty-two will have normal width (12 pixels).

Control Register Definitions (Continued)

Display Window 2 Horizontal Pixel Start Location Register (I²C address 8418h).

REGISTER NAME: HSTRT2 (8418h)

Bit 7							Bit 0
2H7	2H6	2H5	2H4	2H3	2H2	2H1	2H0

Bits 7–0: Display Window 2 Horizontal Pixel Start Location. These seven bits determine the starting horizontal pixel location, which is determined by multiplying the value of these bits by 4 and adding 30 pixels. Due to pipeline delays, the first usable location for the OSD window is approx 42 pixels to the right of the horizontal flyback pulse. For this reason, the display start location must be programmed with a number larger than 2, otherwise improper operation may occur.

This byte must be set so the entire OSD window is within the active video.

Display Window 2 Vertical Pixel Start Location Register (I²C address 8419h).

REGISTER NAME: VSTRT2 (8419h)

Bit 7							Bit 0
2V7	2V6	2V5	2V4	2V3	2V2	2V1	2V0

Bits 7–0: Display Window 2 Vertical Pixel Start Location. These eight bits determine the starting vertical pixel location in constant height character lines, which is determined by multiplying the value of these bits by 2. (Note, each character line is treated as a single auto-height character pixel line, so multiple scan lines may actually be displayed in order to maintain accurate position relative to the character cell size—see *Constant Character Height Mechanism* section).

This byte must be set so the entire OSD window is within the active video.

Display Window 2 Starting Address in the Display Page RAM (I²C address 841Ah–841Bh).

REGISTER NAME: W2STRTADRH (841Bh) W2STRTADRL (841Ah)

Bit 15							Bit 8		Bit 7		Bit 0				
RSV	RSV	RSV	RSV	RSV	RSV	RSV	2ad8	2ad7	2ad6	2ad5	2ad4	2ad3	2ad2	2ad1	2ad0

Bits 8–0: Display Window 2's Starting Address in the Display Page RAM. This register determines the starting address of Display Window 2 in the Display Page RAM. This first address location will always contain the SL code for the first row of Display Window 2.

Bits 7–5: RESERVED.

Display Window 2 Column Width Control Register (I²C address 841Ch–841Fh).

REGISTER NAME: COLWIDTH2B3 (841Fh) COLWIDTH2B2 (841Eh) COLWIDTH2B1 (841Dh) COLWIDTH2B0 (841Ch)

Bit 31								Bit 24		Bit 23		Bit 16				
COL31	COL30	COL29	COL28	COL27	COL26	COL25	COL24	COL23	COL22	COL21	COL20	COL19	COL18	COL17	COL16	
Bit 15							Bit 8		Bit 7		Bit 0					
COL15	COL14	COL13	COL12	COL11	COL10	COL9	COL8	COL7	COL6	COL5	COL4	COL3	COL2	COL1	COL0	

Bits 31–0: Display Window 2 Column Width 2x Enable Bits. These thirty-two bits correspond to columns 31–0 of Display Window 2, respectively. A value of zero indicates the column will have normal width (12 pixels). A value of one indicates the column will be twice as wide as normal (24 pixels). For the double wide case, each Character Font pixel location will be displayed twice, in two consecutive horizontal pixel locations.

The user should note that if more than 32 display characters are programmed to reside on a row, then all display characters after the first thirty-two will have normal width (12 pixels).

Control Register Definitions (Continued)

PRE-AMP INTERFACE REGISTERS

Blue Channel Gain Control Register (I²C address 8430h).

REGISTER NAME: BGINCTRL (8430h)

Bit 7 Bit 0

RSV	BG6	BG5	BG4	BG3	BG2	BG1	BG0
-----	-----	-----	-----	-----	-----	-----	-----

Bits 6–0: Blue Channel Gain Control. These seven bits determine the gain for the Blue Channel.

Bit 7: RESERVED.

Green Channel Gain Control Register (I²C address 8431h).

REGISTER NAME: GGAINCTRL (8431h)

Bit 7 Bit 0

RSV	GG6	GG5	GG4	GG3	GG2	GG1	GG0
-----	-----	-----	-----	-----	-----	-----	-----

Bits 6–0: Green Channel Gain Control. These seven bits determine the gain for the Green Channel.

Bit 7: RESERVED.

Red Channel Gain Control Register (I²C address 8432h).

REGISTER NAME: RGAINCTRL (8432h)

Bit 7 Bit 0

RSV	RG6	RG5	RG4	RG3	RG2	RG1	RG0
-----	-----	-----	-----	-----	-----	-----	-----

Bits 6–0: Red Channel Gain Control. These seven bits determine the gain for the Red Channel.

Bit 7: RESERVED.

Contrast Control Register (I²C address 8433h).

REGISTER NAME: CONTRCTRL (8433h)

Bit 7 Bit 0

RSV	CG6	CG5	CG4	CG3	CG2	CG1	CG0
-----	-----	-----	-----	-----	-----	-----	-----

Bits 6–0: Contrast Gain Control. These six bits determine the overall gain of all three channels.

Bit 7: RESERVED.

Blue Bias Clamp Pulse Amplitude Control Register (I²C address 8434h).

REGISTER NAME: BBIASCTRL (8434h)

Bit 7 Bit 0

BC7	BC6	BC5	BC4	BC3	BC2	BC1	BC0
-----	-----	-----	-----	-----	-----	-----	-----

Bits 7–0: Blue Channel Bias Clamp Pulse Amplitude Control. These six bits determine the bias clamp value for its pulse amplitude.

Green Bias Clamp Pulse Amplitude Control Register (I²C address 8435h).

REGISTER NAME: GBIASCTRL (8435h)

Bit 7 Bit 0

GC7	GC6	GC5	GC4	GC3	GC2	GC1	GC0
-----	-----	-----	-----	-----	-----	-----	-----

Bits 7–0: Green Channel Bias Clamp Pulse Amplitude Control. These six bits determine the bias clamp value for its pulse amplitude.

Control Register Definitions (Continued)

Red Bias Clamp Pulse Amplitude Control Register (I²C address 8436h).

REGISTER NAME: RBIASCTRL (8436h)

Bit 7	Bit 0						
RC7	RC6	RC5	RC4	RC3	RC2	RC1	RC0

Bits 7–0: Red Channel Bias Clamp Pulse Amplitude Control. These six bits determine the bias clamp value for its pulse amplitude.

Brightness Amplitude Control Register (I²C address 8437h).

REGISTER NAME: BRIGHTCTRL (8437h)

Bit 7	Bit 0						
BA7	BA6	BA5	BA4	BA3	BA2	BA1	BA0

Bits 7–0: Brightness Amplitude Control. These six bits determine amplitude of brightness for all three channels.

DC Offset and OSD Contrast Control Register (I²C address 8438h).

REGISTER NAME: DCOFFSET (8438h)

Bit 7	Bit 0						
BP2	BP1	BP0	OSD C1	OSD C0	DC2	DC1	DC0

Bits 2–0: DC Offset Control. These three bits determine the active video DC offset to all three channels.

Bits 4–3: OSD Contrast. These two bits determine the OSD contrast.

Bits 7–5: Blanking pedestal. These three bits determine the blanking pedestal offset for all three channels.

Global Video Control Register (I²C address 8439h).

REGISTER NAME: GLOBALCTRL (8439h)

Bit 7	Bit 0						
RSV	RSV	RSV	RSV	RSV	RSV	PS	BV

Bit 0: Blank Video. When this bit is a one, the video output is blanked. When this bit is a zero normal video is output.

Bit 1: Power Save. When this bit is a one, the analog circuits are shutdown to support sleep mode. When this bit is a zero the analog circuits are enabled for normal operation. See the Power Save Mode section.

Bits 7–2: RESERVED.

PLL Frequency Range Control Register (I²C address 843Eh).

REGISTER NAME: PLLFREQRNG (843Eh)

Bit 7	Bit 0						
RSV	RSV	RSV	RSV	IVS1	IVS0	PFR1	PFR0

Bits 1–0: PLL Frequency Range Control. These bits assist the PLL in locking to the desired pixel frequency. PLL Range should be set as shown in *Table 12*.

Bits 3–2: Sets the approximate Free Run Frequency.

00: 38 kHz, 01: 43 kHz, 10: 47 kHz, 11: 52 kHz.

Bits 7–4: RESERVED. Set to 0

Control Register Definitions (Continued)

TABLE 12. PLL Setting (Register 843Eh)

Note: These settings are valid when R28 = 6.2k, C23 = 0.1 μ F, C33 = 2.2 nF.

Frequency	Range	Value for Register 843Eh
30 kHz	1	01h
35 kHz	1	01h
40 kHz	2	02h
45 kHz	2	02h
50 kHz	2	02h
55 kHz	2	02h
60 kHz	2	02h
65 kHz	2	02h
70 kHz	3	03h
75 kHz	3	03h
80 kHz	3	03h
85 kHz	3	03h
90 kHz	3	03h
95 kHz	3	03h
100 kHz	3	03h

Software Reset and Test Control Register (I²C address 843Fh).

REGISTER NAME: SRTSTCTRL (843Fh)

Bit 7

Bit 0

RSV	AID	RSV	RSV	RSV	RSV	RSV	RSV	SRST
-----	-----	-----	-----	-----	-----	-----	-----	------

Bit 0: Software Reset. Setting this bit causes a software reset. All registers (except this one) are loaded with their default values. All operations currently in progress are aborted (except for I²C transactions). This bit automatically clears itself when the reset has been completed.

Bits 1–5: Reserved

Bit 6: Auto Increment Disable. Setting this bit to one disables the automatic address increment feature of the I²C register access protocol.

Bit 7: Reserved

ATTRIBUTE TABLE AND ENHANCED FEATURES

Each display character and SL in the Display Page RAM will have a 4-bit Attribute Table entry associated with it. The user should note that two-color display characters and four-color display characters use two different Attribute Tables, effectively providing 16 attributes for two-color display characters and 16 attributes for four-color display characters.

For two-color characters the attribute contains the code for the 9-bit foreground color (Color 2), the code for the 9-bit background color (Color 1), and the character's enhanced features (Button Box, Blinking, Heavy Box, Shadowing, bordering, etc.).

For four-color characters the attribute contains the code for the 9-bit Color 1, the code for the 9-bit Color 2, the code for the 9-bit Color 3, the code for the 9-bit Color 4 and the character's enhanced features (Button Box, Blinking, Heavy Box, Shadowing, bordering, etc.).

TWO-COLOR ATTRIBUTE FORMAT

REGISTER NAME: ATT2C3n (8443h +(n*4)), ATT2C2n (8442h +(n*4)),

where n = attribute code (See Table 13)

Bit 31

Bit 24

Bit 23

Bit 16

RSV	RSV	RSV	RSV	RSV	RSV	RSV	RSV	RSV	RSV	RSV	EFB3	EFB2	EFB1	EFB0	C2B2	C2B1
-----	-----	-----	-----	-----	-----	-----	-----	-----	-----	-----	------	------	------	------	------	------

REGISTER NAME: ATT2C1n (8441h +(n*4)), ATT2C0n (8440h +(n*4)),

where n = attribute code (See Table 13)

Bit 15

Bit 8

Bit 7

Bit 0

C2B0	C2G2	C2G1	C2G0	C2R2	C2R1	C2R0	C1B2	C1B1	C1B0	C1G2	C1G1	C1G0	C1R2	C1R1	C1R0
------	------	------	------	------	------	------	------	------	------	------	------	------	------	------	------

Bits 8–0: Color 1. These nine bits indicate the value of the color to be displayed as color 1. This is considered to be the background color and is displayed when the corresponding pixel data bit is a zero.

Bits 17–9: Color 2. These nine bits indicate the value of the color to be displayed as color 2. This is considered to be the foreground color and is displayed when the corresponding pixel data bit is a one.

Control Register Definitions (Continued)

Bits 21–18: Enhanced Feature Bits. The enhanced features are determined as follows:

Bits 21–28	Description
0000b	Normal (no enhanced features enabled).
0001b	Blinking.
0010b	Shadowing.
0011b	Bordering.
01XXb	RESERVED.
1000b	Raised Box.
1001b	Blinking and Raised Box.
1010b	Depressed Box.
1011b	Blinking and Depressed Box.
1100b	Heavy Raised Box.
1101b	Blinking and Heavy Raised Box.
1110b	Heavy Depressed Box.
1111b	Blinking and Heavy Depressed Box.

Bits 31–24: Reserved

FOUR-COLOR ATTRIBUTE FORMAT

REGISTER NAME: ATT4C7n (8507h +(n*4)), ATT4C6n (8506h +(n*4)),

where n = attribute code (See Table 13)

Bit 63												Bit 56		Bit 55		Bit 48						
RSV	RSV	RSV	RSV	RSV	RSV	RSV	RSV	RSV	RSV	RSV	RSV	RSV	RSV	RSV	RSV	C4B2	C4B1					

REGISTER NAME: ATT4C5n (8505h +(n*4)), ATT4C4n (8504h +(n*4)),

where n = attribute code (See Table 13)

Bit 47												Bit 40		Bit 39		Bit 32						
C4B0	C4G2	C4G1	C4G0	C4R2	C4R1	C4R0	C3B2	C3B1	C3B0	C3G2	C3G1	C3G0	C3R2	C3R1	C3R0							

REGISTER NAME: ATT4C3n (8503h +(n*4)), ATT4C2n (8502h +(n*4)),

where n = attribute code (See Table 13)

Bit 31												Bit 24		Bit 23		Bit 16						
RSV	RSV	RSV	RSV	RSV	RSV	RSV	RSV	RSV	RSV	RSV	EFB3	EFB2	EFB1	EFB0	C2B2	C2B1						

REGISTER NAME: ATT4C1n (8501h +(n*4)), ATT4C0n (8500h +(n*4)),

where n = attribute code (See Table 13)

Bit 15												Bit 8		Bit 7		Bit 0						
C2B0	C2G2	C2G1	C2G0	C2R2	C2R1	C2R0	C1B2	C1B1	C1B0	C1G2	C1G1	C1G0	C1R2	C1R1	C1R0							

Bits 8–0: Color 1. These nine bits indicate the value of the color to be displayed as Color 1. This is considered to be the background color and is displayed when the corresponding pixel data bit is 00b

Bits 17–9: Color 2. These nine bits indicate the value of the color to be displayed as Color 2. This is displayed when the corresponding pixel data bit is 01b

Bits 21–18: Enhanced Feature Bits. The enhanced features are determined as follows:

Bits 21–18	Description
0000b	Normal (no enhanced features enabled).
0001b	Blinking.
001Xb	RESERVED.
01XXb	RESERVED.
1000b	Raised Box.
1001b	Blinking and Raised Box.

Control Register Definitions (Continued)

Bits 21–18	Description
1010b	Depressed Box.
1011b	Blinking and Depressed Box.
1100b	Heavy Raised Box.
1101b	Blinking and Heavy Raised Box.
1110b	Heavy Depressed Box.
1111b	Blinking and Heavy Depressed Box.

Bits 40–32: Color 3. These nine bits indicate the value of the color to be displayed as Color 3. This is displayed when the corresponding pixel data bit is 10b.

Bits 49–41: Color 4. These nine bits indicate the value of the color to be displayed as Color 4. This is displayed when the corresponding pixel data bit is 11b.

Bits 63–50: RESERVED.

ATTRIBUTE TABLES TO I²C ADDRESS

TABLE 13. Attribute Tables To I²C Address

Attribute Value	Two-Color Attribute Table	Four-Color Attribute Table
	I ² C Address	I ² C Address
0000b	8440h–8443h	8500h–8507h
0001b	8444h–8447h	8508h–850Fh
0010b	8448h–844Bh	8510h–8517h
0011b	844Ch–844Fh	8518h–851Fh
0100b	8450h–8453h	8520h–8527h
0101b	8454h–8457h	8528h–852Fh
0110b	8458h–845Bh	8530h–8537h
0111b	845Ch–845Fh	8538h–853Fh
1000b	8460h–8463h	8540h–8547h
1001b	8464h–8467h	8548h–854Fh
1010b	8468h–846Bh	8550h–8557h
1011b	846Ch–846Fh	8558h–855Fh
1100b	8470h–8473h	8560h–8567h
1101b	8474h–8477h	8568h–856Fh
1110b	8478h–847Bh	8570h–8577h
1111b	847Ch–847Fh	8578h–857Fh

Button Box Formation

The value of the most significant Enhanced Feature Bit (EFB3) determines when to draw the left, right, bottom and top sides of a Box. EFB1 denotes whether a box is raised or depressed, and EFB2 denotes whether the box is normal or 'heavy'. For normal boxes, the lowlight color is determined by the color code stored in the register EF2. For the heavy box feature, the lowlight is determined by color code stored in register EF3.

Boxes are created by a 'pixel override' system that overwrites character cell pixel information with either the highlight color (EF1) or low light shadow (EF2 or EF3) of the box. Only the top pixel line of the character and the right edge of the character can be overwritten by the pixel override system.

To form a complete box, the left hand edge of a box is created by overwriting the pixels in the right most column of the preceding character to the one being enclosed by the box.

The bottom edge of a box is created by either

1. overwriting the pixels in the top line of the character below the character being enclosed by the box.

Or:

Control Register Definitions (Continued)

2. overwriting the pixels in the top line of the skipped lines below, in the case where skip lines are present below a boxed character.

Characters should be designed so that button boxes will not interfere with the character.

Some minor limitations result from the above box formation methodology:

- No box may use the left most display character in the Display Window, or it will have no left side of the Box. To create a box around the left most displayed character, a transparent 'blank' character must be used in the first character position. This character will not be visible on the screen, but allows the formation of the box.
- At least one skip line must be used beneath characters on the bottom row, if a box is required around any characters on this row in order to accommodate the bottom edge of the box.
- Skipped lines cannot be used within a box covering several rows
- Irregular shaped boxes, (i.e., other than rectangular), may have some missing edges.

Operation of the Shadow Feature

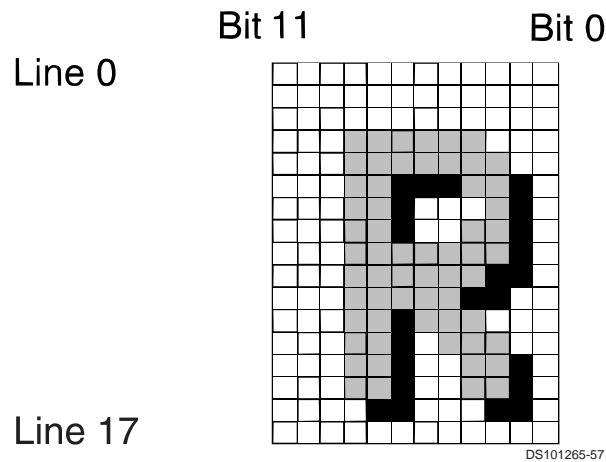

FIGURE 44. Operation of the Shadow Feature

The shadow feature is created as follows: as each 12 bit line in the character is called from ROM, the line immediately preceding it is also called and used to create a 'pixel override' mask. Bits 11 through 1 of the preceding line are compared to bits 10 through 0 of the current character line. Each bit X in the current line is compared to bit X+1 in the preceding line (i.e., the pixel above and to the left of the current pixel). Note that bit 11 of the current line cannot be shadowed. A pixel override output mask is then created.

When a pixel override output is 1 for a given pixel position, the color of that pixel must be substituted with the color code stored in the register EF3.

Operation of the Bordering Feature

Borders are created in a similar manner to shadowing, using the pixel override system to over write pixel data with a pixel color set by EF3. However, instead of comparing just the previous line to the current line, all pixels surrounding a given pixel are examined.

The shadow feature is created as follows: as each 12 bit line in the character is called from ROM, the character line immediately above and the line immediately below are also called. A 'Pixel Override' output mask is then created by looking at all pixels surrounding the pixel.

When a black override output is 1 for a given pixel position, X, the color of that pixel must be substituted with the color code stored in the register EF3.

Because the shadowing relies upon information about the pixels surrounding any given pixel, the bordering system may not operate correctly for pixels in line 0, line 17, and column 0 and column 11.

Constant Character Height Mechanism

The CRT monitor scan circuits ensure that the height of the displayed image remains constant so the physical height of a single displayed pixel row will decrease as the total number of vertical image lines increases. As the OSD character matrix has a fixed number of lines, C, (where C=18), then the character height will reduce as the number of scan lines increase, assuming a constant image height. To prevent this, the OSD generator repeats some of the lines in the OSD character in order to maintain a constant height.

Control Register Definitions (Continued)

In the LM1253A, an approximation method is used to determine which lines are repeated, and how many times each line is repeated.

The constant character height mechanism will not decrease the OSD character matrix to less than 18 lines. Each character will be at least 18 lines high.

Display Window 1 To Display Window 2 Spacing

There is no required vertical spacing between Display Window 1 and Display Window 2, but they should not overlap.

There must be a two character horizontal space between Display Window 1 and Display Window 2 for proper operation of both windows or undefined results may occur.

Evaluation Character Fonts

The character font of the LM1253A is shown in *Figures 45, 46, 47, 48, 49, 50*.

Note that the first two character codes of the two color font (00h and 01h) are reserved for the Window End (WE) and Row End (RE) codes respectively.

Character Font

Control Code	Control Code						
"Window End"	"Row End"						
00	01	A	B	C	D	E	F
G	H	I	J	K	L	M	N
08	09	0A	0B	0C	0D	0E	0F
O	P	Q	R	S	T	U	V
10	11	12	13	14	15	16	17
W	X	Y	Z	[]	_	~
18	19	1A	1B	1C	1D	1E	1F
.	,	a	b	c	d	e	f
20	21	22	23	24	25	26	27
g	h	i	j	k	l	m	n
28	29	2A	2B	2C	2D	2E	2F

Color 1 - White 
 Color 2 - Black 

DS101265-62

FIGURE 45. Character Font 00-2F

Character Font (Continued)

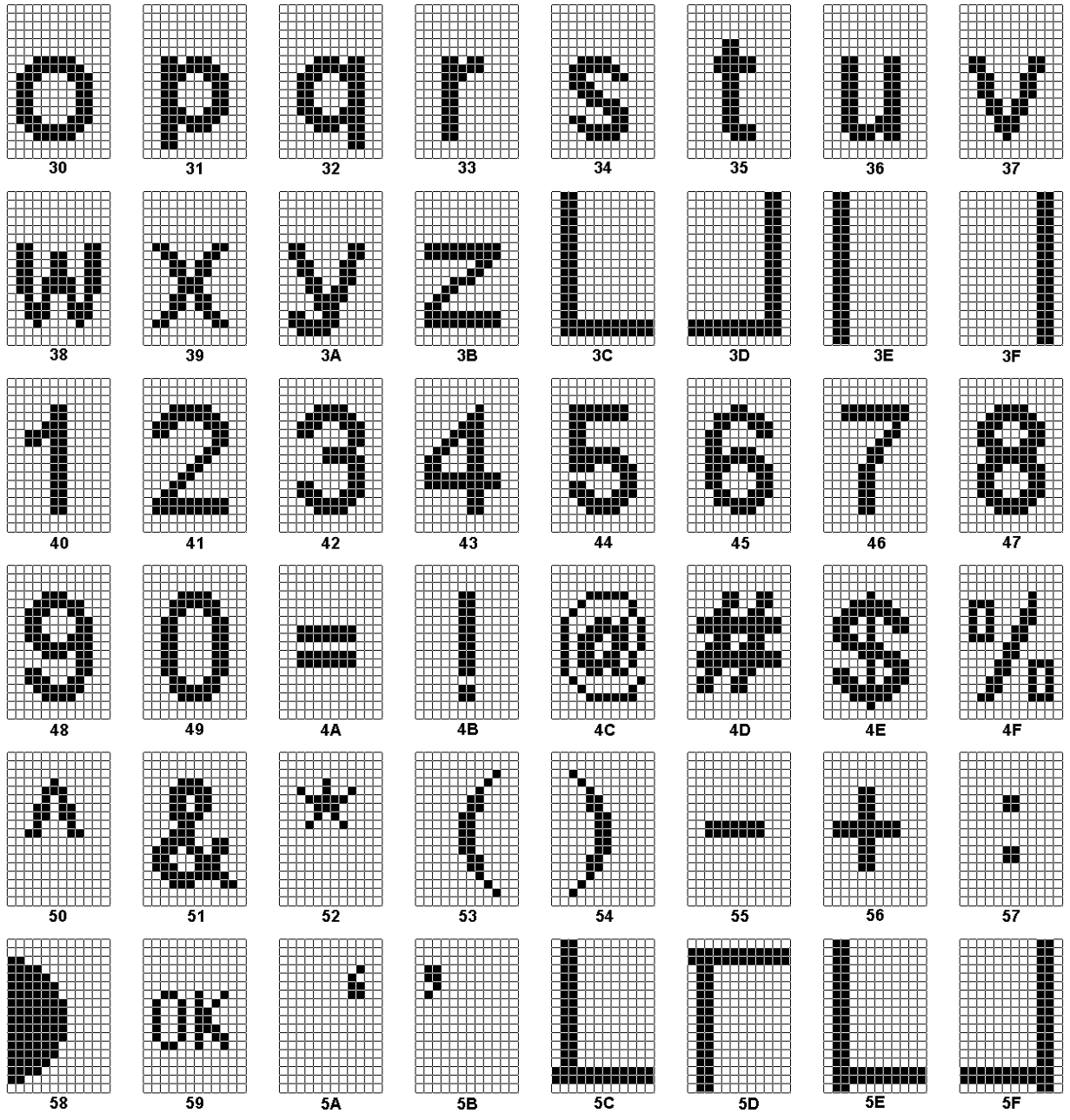

Color 1 - White 
 Color 2 - Black 

FIGURE 46. Character Font 30-5F

DS101265-63

Character Font (Continued)

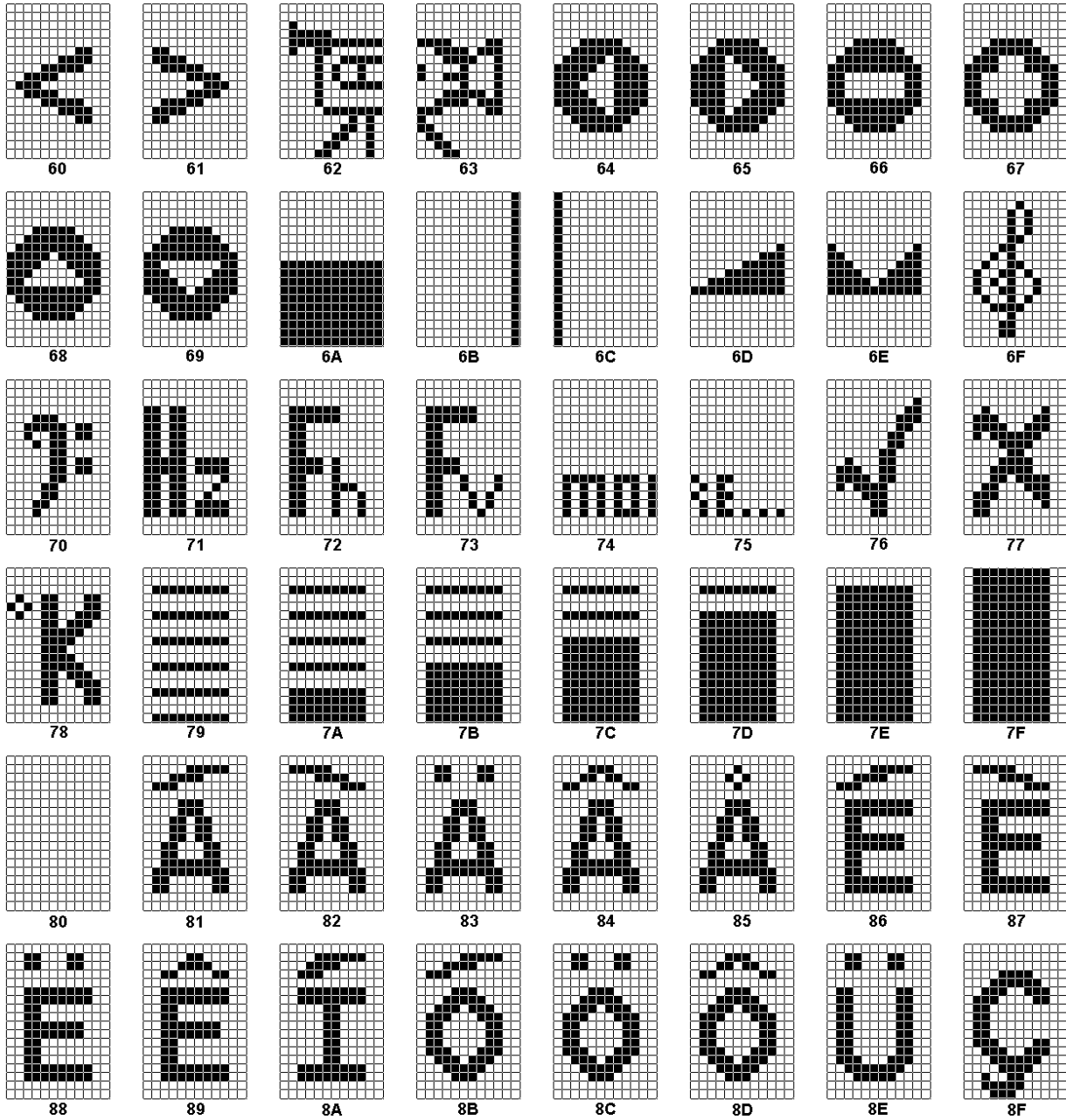

Color 1 - White 
 Color 2 - Black 

DS101265-64

FIGURE 47. Character Font 60-8F

Character Font (Continued)

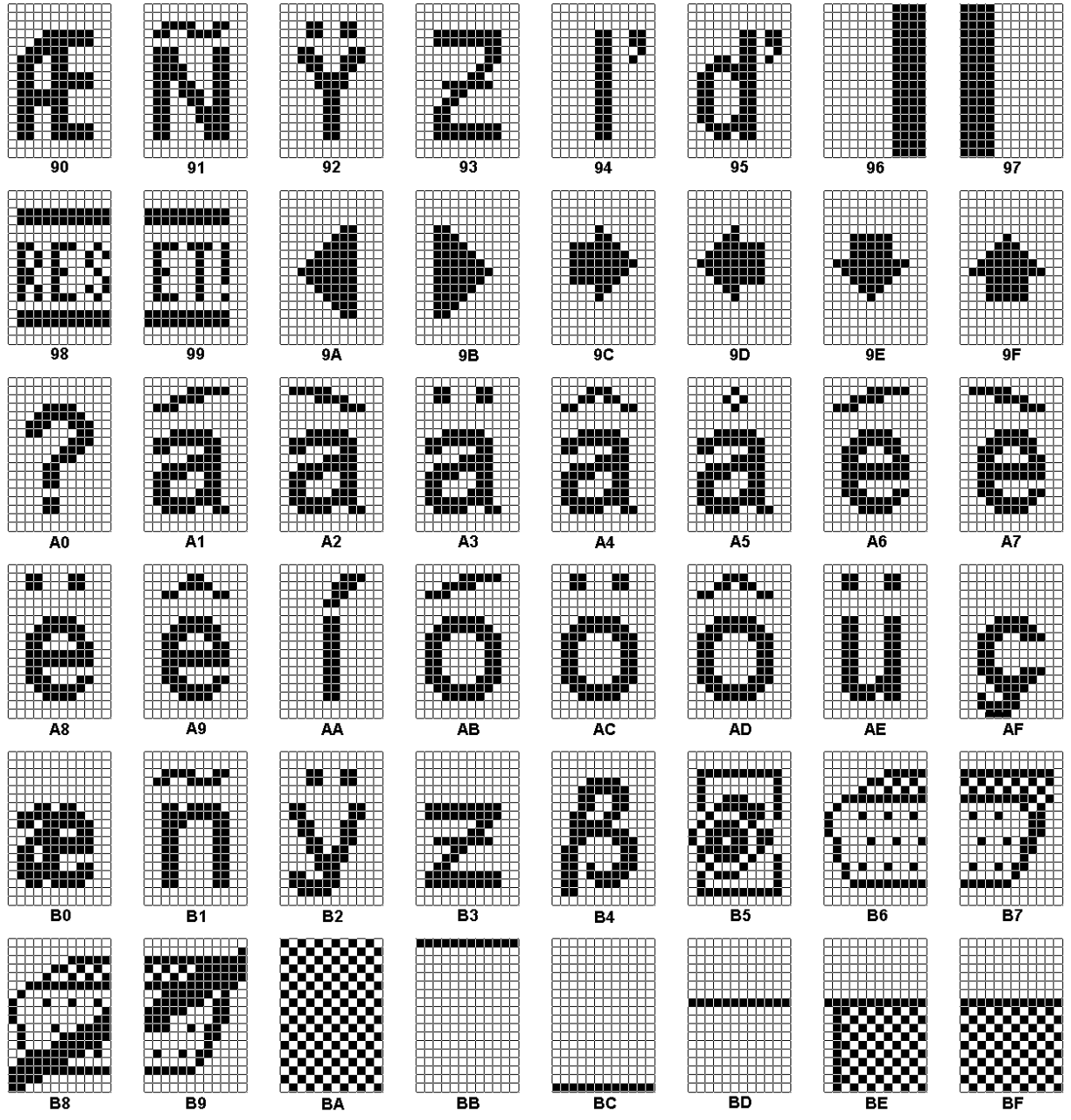

Color 1 - White 
 Color 2 - Black 

DS101265-65

FIGURE 48. Character Font 90-BF

Character Font (Continued)

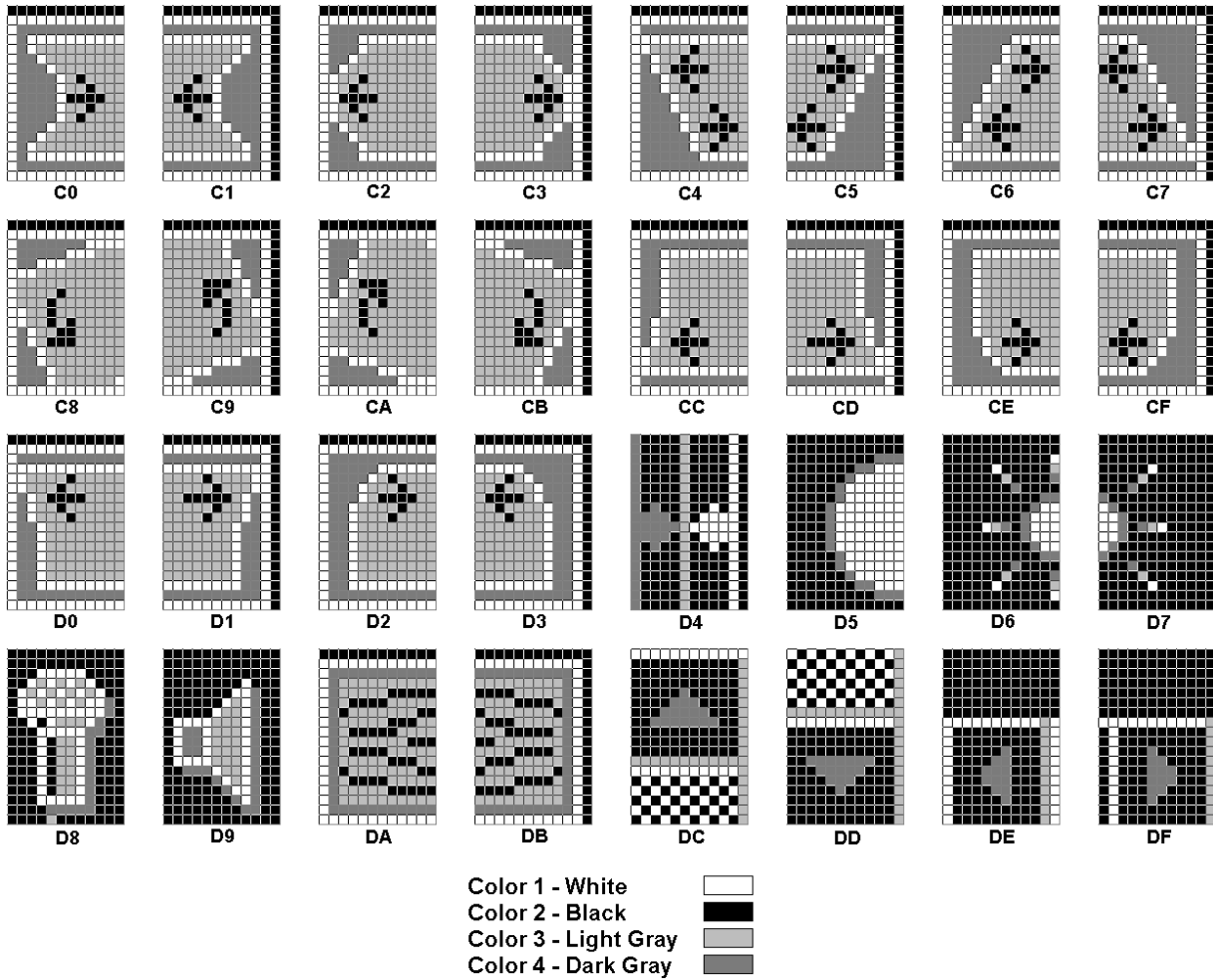

FIGURE 49. Character Font C0-DF

DS101265-66

Character Font (Continued)

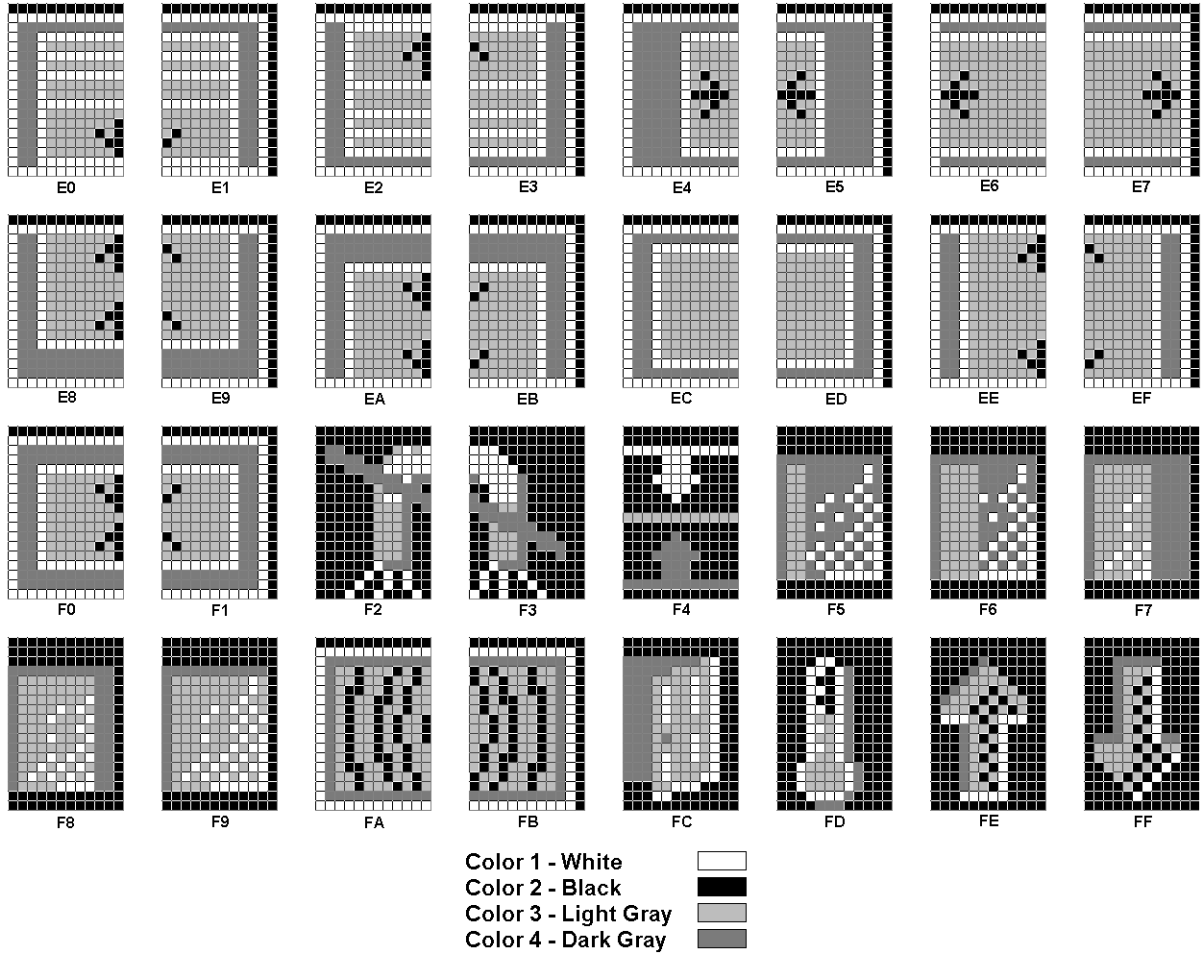
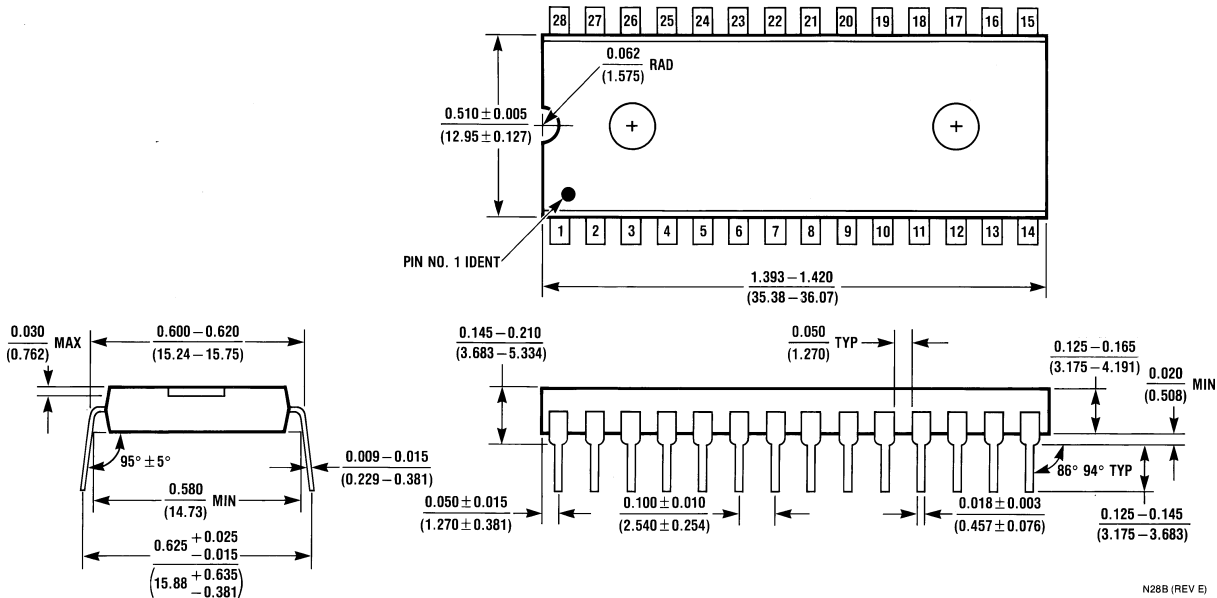

FIGURE 50. Character Font E0-FF

DS101265-67

Physical Dimensions inches (millimeters) unless otherwise noted



28-Lead (0.600" wide) Molded Dual-In-Line Package
Order Number LM1253AN
NS Package Number N28B

LIFE SUPPORT POLICY

NATIONAL'S PRODUCTS ARE NOT AUTHORIZED FOR USE AS CRITICAL COMPONENTS IN LIFE SUPPORT DEVICES OR SYSTEMS WITHOUT THE EXPRESS WRITTEN APPROVAL OF THE PRESIDENT AND GENERAL COUNSEL OF NATIONAL SEMICONDUCTOR CORPORATION. As used herein:

1. Life support devices or systems are devices or systems which, (a) are intended for surgical implant into the body, or (b) support or sustain life, and whose failure to perform when properly used in accordance with instructions for use provided in the labeling, can be reasonably expected to result in a significant injury to the user.
2. A critical component is any component of a life support device or system whose failure to perform can be reasonably expected to cause the failure of the life support device or system, or to affect its safety or effectiveness.

National Semiconductor Corporation
Americas
Tel: 1-800-272-9959
Fax: 1-800-737-7018
Email: support@nsc.com
www.national.com

National Semiconductor Europe
Fax: +49 (0) 180-530 85 86
Email: europe.support@nsc.com
Deutsch Tel: +49 (0) 69 9508 6208
English Tel: +44 (0) 870 24 0 2171
Français Tel: +33 (0) 1 41 91 8790

National Semiconductor Asia Pacific Customer Response Group
Tel: 65-2544466
Fax: 65-2504466
Email: ap.support@nsc.com

National Semiconductor Japan Ltd.
Tel: 81-3-5639-7560
Fax: 81-3-5639-7507