

LM13700

Dual Operational Transconductance Amplifiers with Linearizing Diodes and Buffers

General Description

The LM13700 series consists of two current controlled transconductance amplifiers, each with differential inputs and a push-pull output. The two amplifiers share common supplies but otherwise operate independently. Linearizing diodes are provided at the inputs to reduce distortion and allow higher input levels. The result is a 10 dB signal-to-noise improvement referenced to 0.5 percent THD. High impedance buffers are provided which are especially designed to complement the dynamic range of the amplifiers. The output buffers of the LM13700 differ from those of the LM13600 in that their input bias currents (and hence their output DC levels) are independent of I_{ABC} . This may result in performance superior to that of the LM13600 in audio applications.

Features

- g_m adjustable over 6 decades
- Excellent g_m linearity
- Excellent matching between amplifiers
- Linearizing diodes
- High impedance buffers
- High output signal-to-noise ratio

Applications

- Current-controlled amplifiers
- Current-controlled impedances
- Current-controlled filters
- Current-controlled oscillators
- Multiplexers
- Timers
- Sample-and-hold circuits

Connection Diagram

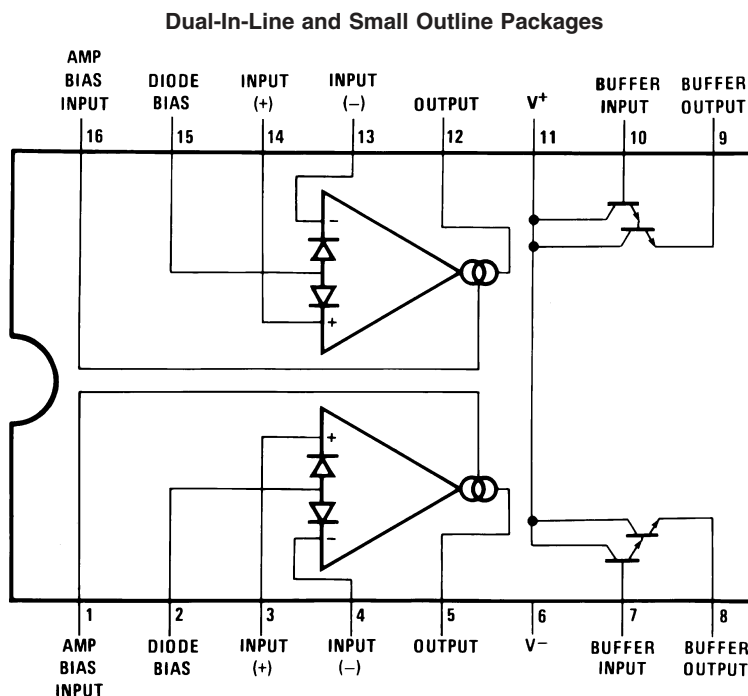

00798102

Top View
Order Number LM13700M, LM13700MX or LM13700N
See NS Package Number M16A or N16A

Absolute Maximum Ratings (Note 1)

If Military/Aerospace specified devices are required, please contact the National Semiconductor Sales Office/Distributors for availability and specifications.

Supply Voltage	
LM13700	36 V _{DC} or ±18V
Power Dissipation (Note 2) T _A = 25°C	
LM13700N	570 mW
Differential Input Voltage	±5V
Diode Bias Current (I _D)	2 mA
Amplifier Bias Current (I _{ABC})	2 mA
Output Short Circuit Duration	Continuous

Buffer Output Current (Note 3)	20 mA
Operating Temperature Range	
LM13700N	0°C to +70°C
DC Input Voltage	+V _S to -V _S
Storage Temperature Range	-65°C to +150°C
Soldering Information	
Dual-In-Line Package	
Soldering (10 sec.)	260°C
Small Outline Package	
Vapor Phase (60 sec.)	215°C
Infrared (15 sec.)	220°C

Electrical Characteristics (Note 4)

Parameter	Conditions	LM13700			Units
		Min	Typ	Max	
Input Offset Voltage (V _{OS})	Over Specified Temperature Range I _{ABC} = 5 μA		0.4 0.3	4 4	mV
V _{OS} Including Diodes	Diode Bias Current (I _D) = 500 μA		0.5	5	mV
Input Offset Change	5 μA ≤ I _{ABC} ≤ 500 μA		0.1	3	mV
Input Offset Current			0.1	0.6	μA
Input Bias Current	Over Specified Temperature Range		0.4 1	5 8	μA
Forward Transconductance (g _m)	Over Specified Temperature Range	6700 5400	9600	13000	μmho
g _m Tracking			0.3		dB
Peak Output Current	R _L = 0, I _{ABC} = 5 μA		5		μA
	R _L = 0, I _{ABC} = 500 μA	350	500	650	
	R _L = 0, Over Specified Temp Range	300			
Peak Output Voltage					
Positive	R _L = ∞, 5 μA ≤ I _{ABC} ≤ 500 μA	+12	+14.2		V
Negative	R _L = ∞, 5 μA ≤ I _{ABC} ≤ 500 μA	-12	-14.4		V
Supply Current	I _{ABC} = 500 μA, Both Channels		2.6		mA
V _{OS} Sensitivity					
Positive	ΔV _{OS} /ΔV ⁺		20	150	μV/V
Negative	ΔV _{OS} /ΔV ⁻		20	150	μV/V
CMRR		80	110		dB
Common Mode Range		±12	±13.5		V
Crosstalk	Referred to Input (Note 5) 20 Hz < f < 20 kHz		100		dB
Differential Input Current	I _{ABC} = 0, Input = ±4V		0.02	100	nA
Leakage Current	I _{ABC} = 0 (Refer to Test Circuit)		0.2	100	nA
Input Resistance		10	26		kΩ
Open Loop Bandwidth			2		MHz
Slew Rate	Unity Gain Compensated		50		V/μs
Buffer Input Current	(Note 5)		0.5	2	μA
Peak Buffer Output Voltage	(Note 5)	10			V

Note 1: "Absolute Maximum Ratings" indicate limits beyond which damage to the device may occur. Operating Ratings indicate conditions for which the device is functional, but do not guarantee specific performance limits.

Note 2: For operation at ambient temperatures above 25°C, the device must be derated based on a 150°C maximum junction temperature and a thermal resistance, junction to ambient, as follows: LM13700N, 90°C/W; LM13700M, 110°C/W.

Note 3: Buffer output current should be limited so as to not exceed package dissipation.

Electrical Characteristics (Note 4) (Continued)

Note 4: These specifications apply for $V_S = \pm 15V$, $T_A = 25^\circ C$, amplifier bias current ($I_{ABC} = 500 \mu A$, pins 2 and 15 open unless otherwise specified. The inputs to the buffers are grounded and outputs are open.

Note 5: These specifications apply for $V_S = \pm 15V$, $I_{ABC} = 500 \mu A$, $R_{OUT} = 5 k\Omega$ connected from the buffer output to $-V_S$ and the input of the buffer is connected to the transconductance amplifier output.

Schematic Diagram

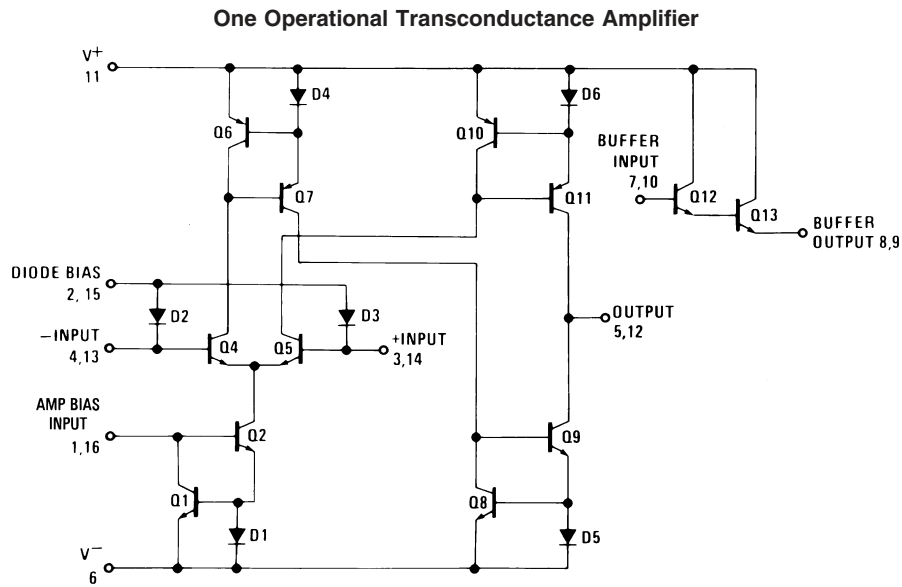

00798101

Typical Application

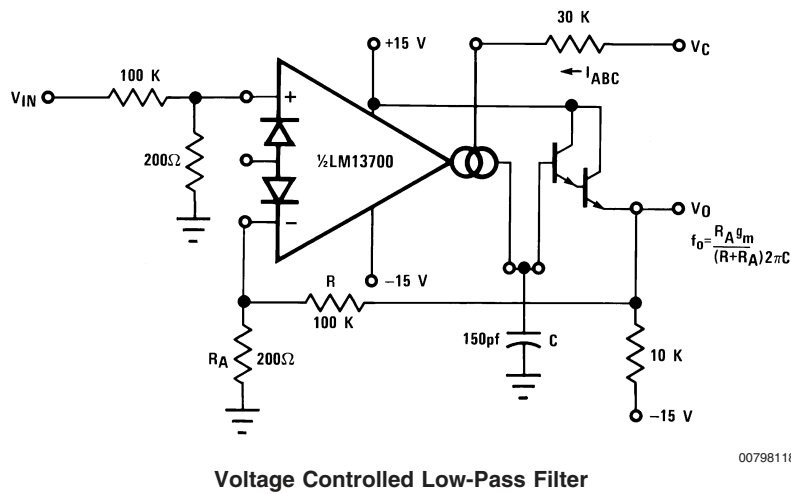

00798118

Typical Performance Characteristics

Input Offset Voltage

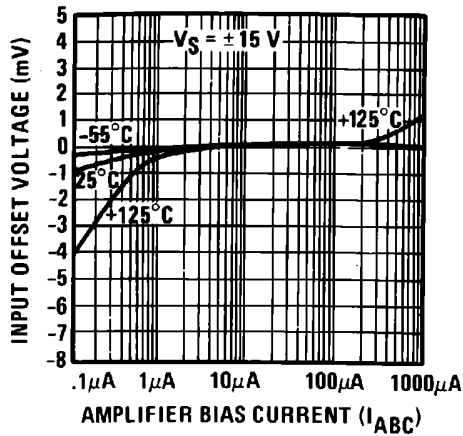

00798138

Input Offset Current

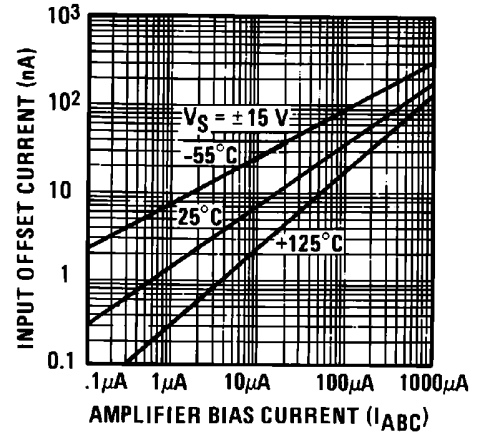

00798139

Input Bias Current

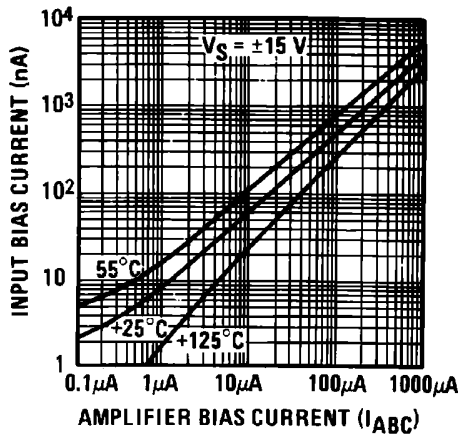

00798140

Peak Output Current

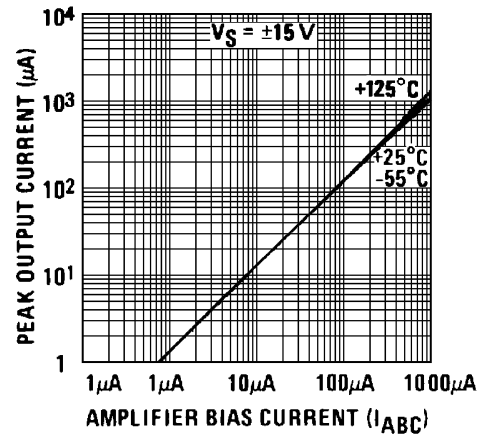

00798141

Peak Output Voltage and Common Mode Range

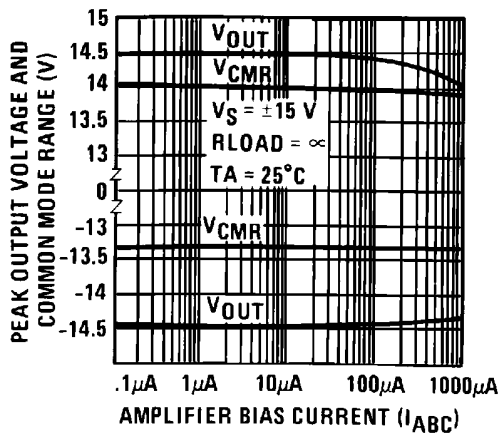

00798142

Leakage Current

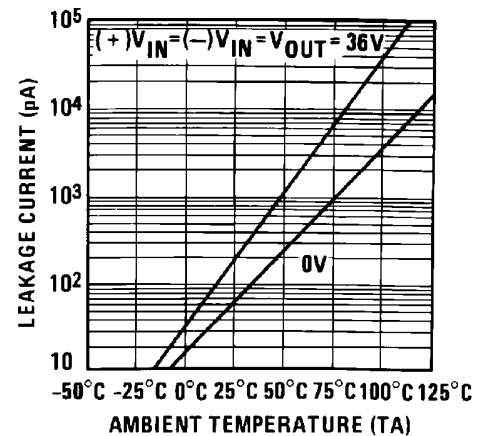

00798143

Typical Performance Characteristics (Continued)

Input Leakage

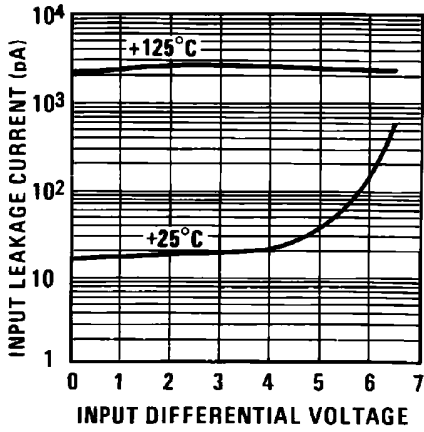

00798144

Transconductance

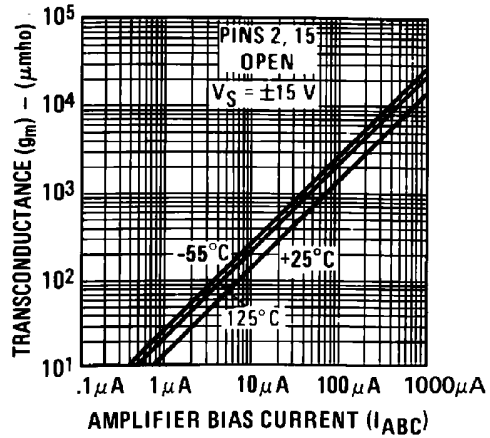

00798145

Input Resistance

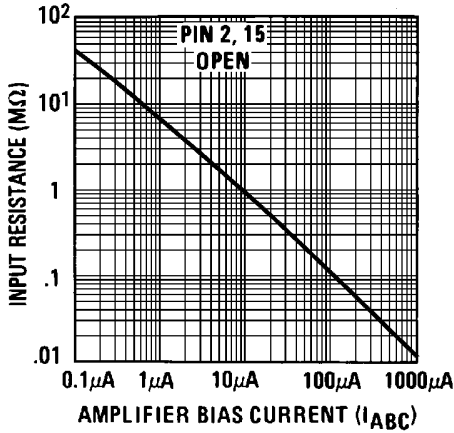

00798146

Amplifier Bias Voltage vs. Amplifier Bias Current

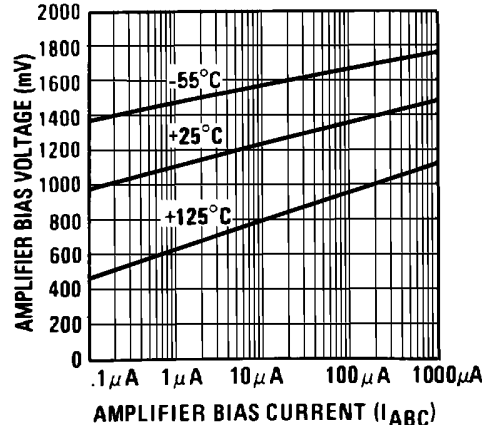

00798147

Input and Output Capacitance

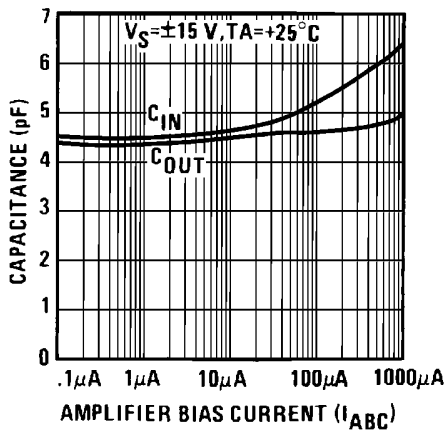

00798148

Output Resistance

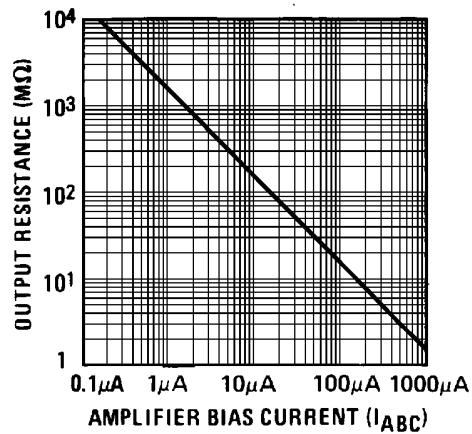

00798149

Typical Performance Characteristics (Continued)

Distortion vs. Differential Input Voltage

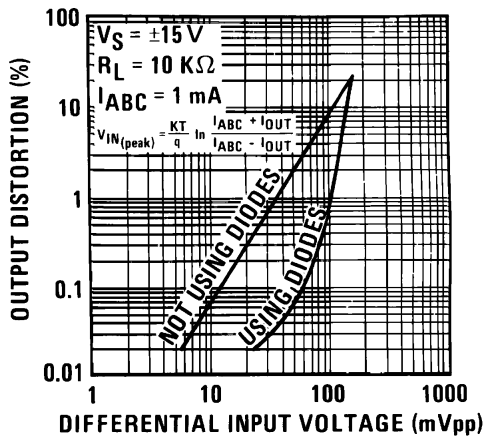

00798150

Voltage vs. Amplifier Bias Current

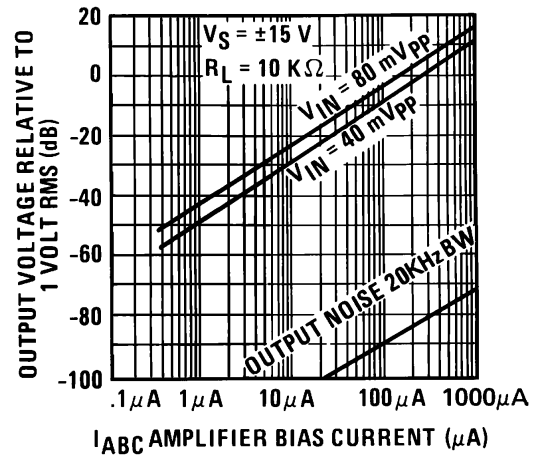

00798151

Output Noise vs. Frequency

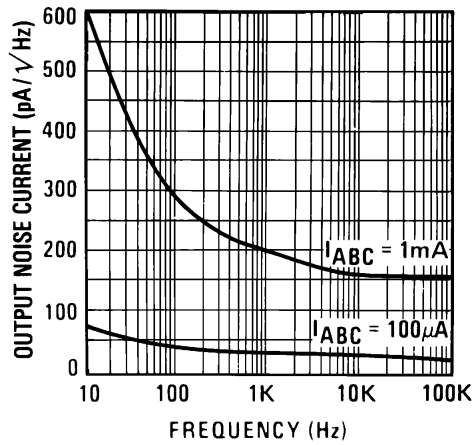

00798152

Unity Gain Follower

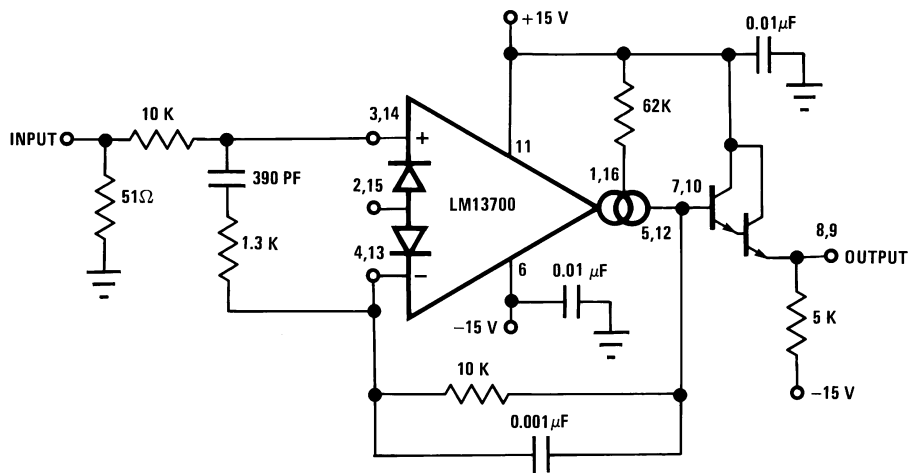

00798105

Typical Performance Characteristics (Continued)

Leakage Current Test Circuit

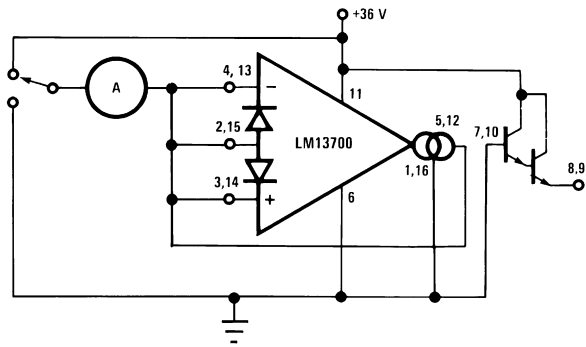

00798106

Differential Input Current Test Circuit

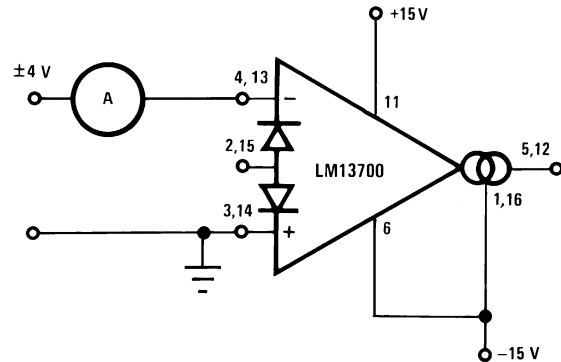

00798107

Circuit Description

The differential transistor pair Q_4 and Q_5 form a transconductance stage in that the ratio of their collector currents is defined by the differential input voltage according to the transfer function:

$$V_{IN} = \frac{kT}{q} \ln \frac{I_5}{I_4} \quad (1)$$

where V_{IN} is the differential input voltage, kT/q is approximately 26 mV at 25°C and I_5 and I_4 are the collector currents of transistors Q_5 and Q_4 respectively. With the exception of Q_{12} and Q_{13} , all transistors and diodes are identical in size. Transistors Q_1 and Q_2 with Diode D_1 form a current mirror which forces the sum of currents I_4 and I_5 to equal I_{ABC} :

$$I_4 + I_5 = I_{ABC} \quad (2)$$

where I_{ABC} is the amplifier bias current applied to the gain pin.

For small differential input voltages the ratio of I_4 and I_5 approaches unity and the Taylor series of the \ln function can be approximated as:

$$\begin{aligned} \frac{kT}{q} \ln \frac{I_5}{I_4} &\approx \frac{kT}{q} \frac{I_5 - I_4}{I_4} \\ I_4 &\approx I_5 \approx \frac{I_{ABC}}{2} \end{aligned} \quad (3)$$

$$V_{IN} \left[\frac{I_{ABC}^q}{2kT} \right] = I_5 - I_4 \quad (4)$$

Collector currents I_4 and I_5 are not very useful by themselves and it is necessary to subtract one current from the other. The remaining transistors and diodes form three current mirrors that produce an output current equal to I_5 minus I_4 thus:

$$V_{IN} \left[\frac{I_{ABC}^q}{2kT} \right] = I_{OUT} \quad (5)$$

The term in brackets is then the transconductance of the amplifier and is proportional to I_{ABC} .

Linearizing Diodes

For differential voltages greater than a few millivolts, *Equation (3)* becomes less valid and the transconductance becomes increasingly nonlinear. *Figure 1* demonstrates how the internal diodes can linearize the transfer function of the amplifier. For convenience assume the diodes are biased with current sources and the input signal is in the form of current I_S . Since the sum of I_4 and I_5 is I_{ABC} and the difference is I_{OUT} , currents I_4 and I_5 can be written as follows:

$$I_4 = \frac{I_{ABC}}{2} - \frac{I_{OUT}}{2}, \quad I_5 = \frac{I_{ABC}}{2} + \frac{I_{OUT}}{2}$$

Since the diodes and the input transistors have identical geometries and are subject to similar voltages and temperatures, the following is true:

$$\begin{aligned} \frac{kT}{q} \ln \frac{\frac{I_D}{2} + I_S}{\frac{I_D}{2} - I_S} &= \frac{kT}{q} \ln \frac{\frac{I_{ABC}}{2} + \frac{I_{OUT}}{2}}{\frac{I_{ABC}}{2} - \frac{I_{OUT}}{2}} \\ \therefore I_{OUT} &= I_S \left(\frac{2I_{ABC}}{I_D} \right) \text{ for } |I_S| < \frac{I_D}{2} \end{aligned} \quad (6)$$

Notice that in deriving *Equation (6)* no approximations have been made and there are no temperature-dependent terms. The limitations are that the signal current not exceed $I_D/2$ and that the diodes be biased with currents. In practice, replacing the current sources with resistors will generate insignificant errors.

Applications

Voltage Controlled Amplifiers

Figure 2 shows how the linearizing diodes can be used in a voltage-controlled amplifier. To understand the input biasing, it is best to consider the 13 k Ω resistor as a current source and use a Thevenin equivalent circuit as shown in *Figure 3*. This circuit is similar to *Figure 1* and operates the same. The potentiometer in *Figure 2* is adjusted to minimize the effects of the control signal at the output.

Applications

Voltage Controlled Amplifiers (Continued)

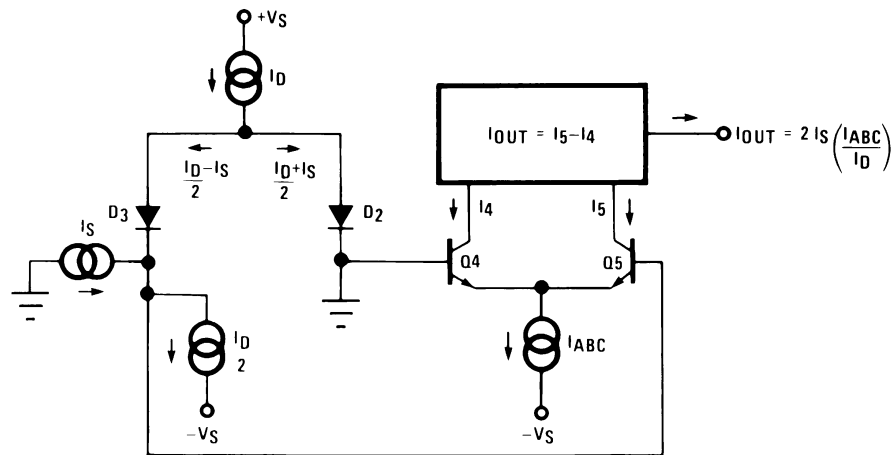

00798108

FIGURE 1. Linearizing Diodes

For optimum signal-to-noise performance, I_{ABC} should be as large as possible as shown by the Output Voltage vs. Amplifier Bias Current graph. Larger amplitudes of input signal also improve the S/N ratio. The linearizing diodes help here by allowing larger input signals for the same output distortion as shown by the Distortion vs. Differential Input Voltage graph. S/N may be optimized by adjusting the magnitude of the input signal via R_{IN} (Figure 2) until the output distortion is below some desired level. The output voltage swing can then be set at any level by selecting R_L .

Although the noise contribution of the linearizing diodes is negligible relative to the contribution of the amplifier's internal transistors, I_D should be as large as possible. This minimizes the dynamic junction resistance of the diodes (r_e) and maximizes their linearizing action when balanced against R_{IN} . A value of 1 mA is recommended for I_D unless the specific application demands otherwise.

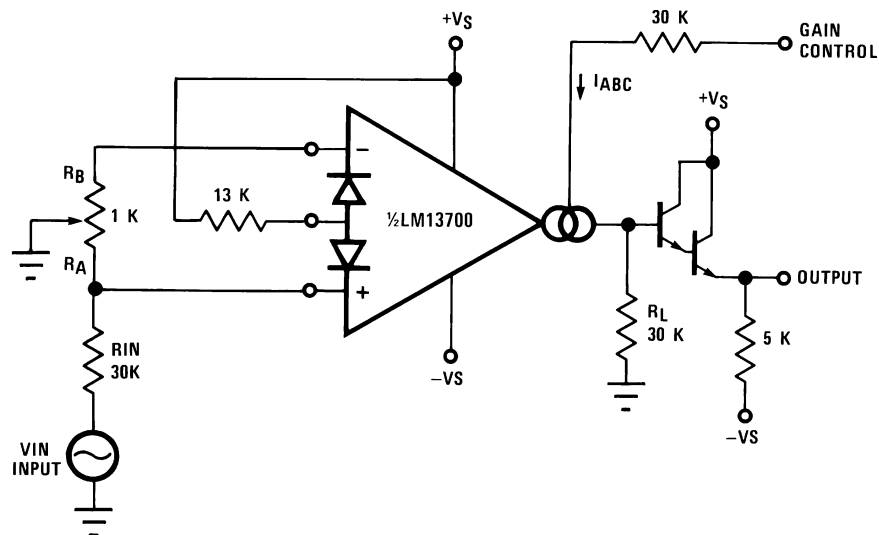

00798109

FIGURE 2. Voltage Controlled Amplifier

Applications

Voltage Controlled Amplifiers (Continued)

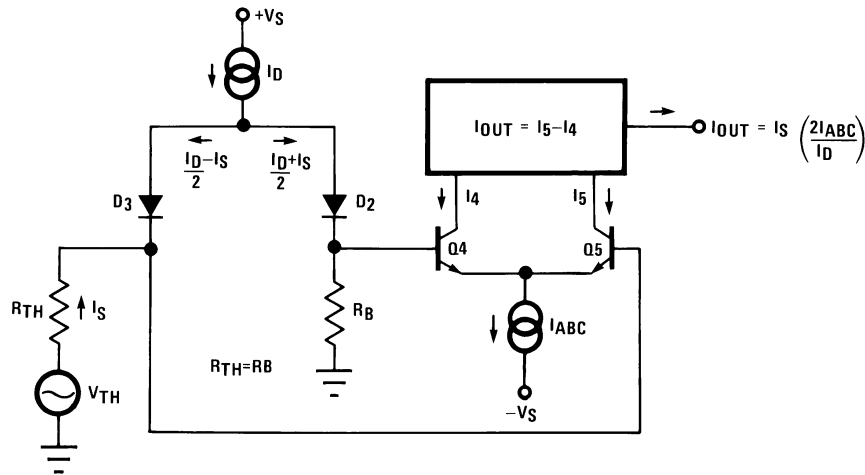

00798110

FIGURE 3. Equivalent VCA Input Circuit

Stereo Volume Control

The circuit of *Figure 4* uses the excellent matching of the two LM13700 amplifiers to provide a Stereo Volume Control with a typical channel-to-channel gain tracking of 0.3 dB. R_P is provided to minimize the output offset voltage and may be replaced with two 510 Ω resistors in AC-coupled applications. For the component values given, amplifier gain is derived for *Figure 2* as being:

$$\frac{V_O}{V_{IN}} = 940 \times I_{ABC}$$

If V_C is derived from a second signal source then the circuit becomes an amplitude modulator or two-quadrant multiplier as shown in *Figure 5*, where:

$$I_O = \frac{-2I_S}{I_D} (I_{ABC}) = \frac{-2I_S}{I_D} \frac{V_{IN2}}{R_C} - \frac{2I_S}{I_D} \frac{(V^- + 1.4V)}{R_C}$$

The constant term in the above equation may be cancelled by feeding $I_S \times I_D R_C / 2(V^- + 1.4V)$ into I_O . The circuit of *Figure 6* adds R_M to provide this current, resulting in a four-quadrant multiplier where R_C is trimmed such that $V_O = 0V$ for $V_{IN2} = 0V$. R_M also serves as the load resistor for I_O .

Stereo Volume Control (Continued)

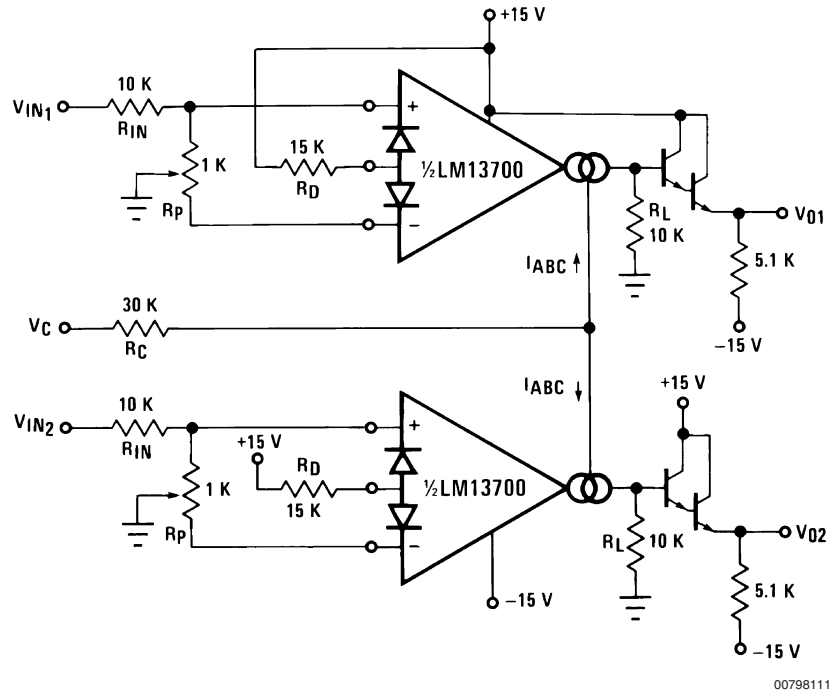

FIGURE 4. Stereo Volume Control

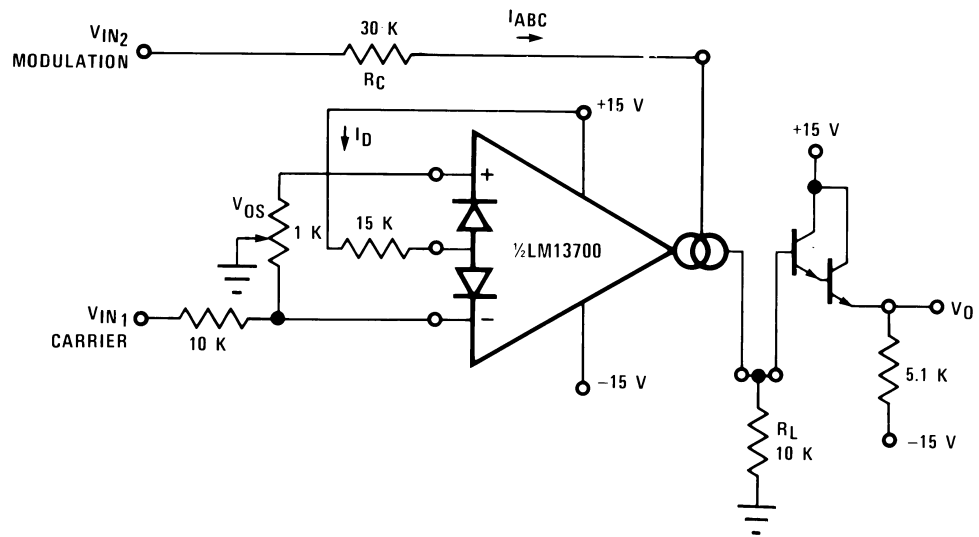

FIGURE 5. Amplitude Modulator

Stereo Volume Control (Continued)

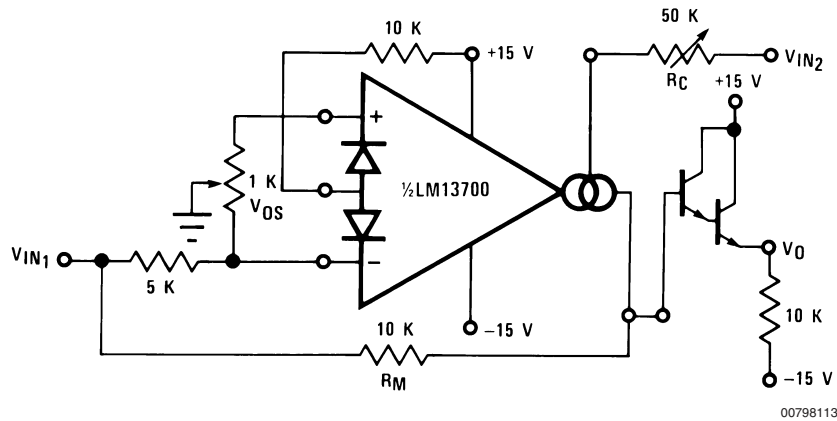

FIGURE 6. Four-Quadrant Multiplier

Noting that the gain of the LM13700 amplifier of *Figure 3* may be controlled by varying the linearizing diode current I_D as well as by varying I_{ABC} , *Figure 7* shows an AGC Amplifier using this approach. As V_O reaches a high enough amplitude ($3V_{BE}$) to turn on the Darlington transistors and the linearizing diodes, the increase in I_D reduces the amplifier gain so as to hold V_O at that level.

Voltage Controlled Resistors

An Operational Transconductance Amplifier (OTA) may be used to implement a Voltage Controlled Resistor as shown in *Figure 8*. A signal voltage applied at R_X generates a V_{IN} to the LM13700 which is then multiplied by the g_m of the amplifier to produce an output current, thus:

$$R_X = \frac{R + R_A}{g_m R_A}$$

where $g_m \approx 19.2I_{ABC}$ at 25°C . Note that the attenuation of V_O by R and R_A is necessary to maintain V_{IN} within the linear range of the LM13700 input.

Figure 9 shows a similar VCR where the linearizing diodes are added, essentially improving the noise performance of the resistor. A floating VCR is shown in *Figure 10*, where each "end" of the "resistor" may be at any voltage within the output voltage range of the LM13700.

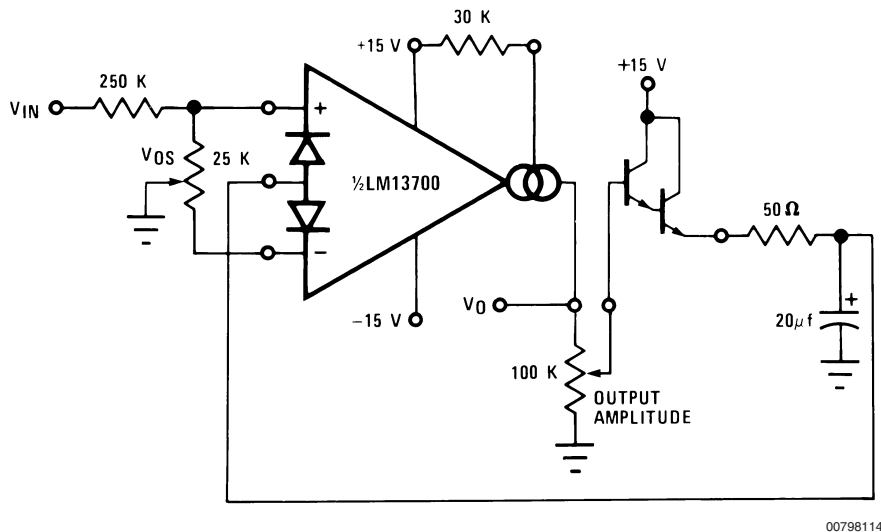
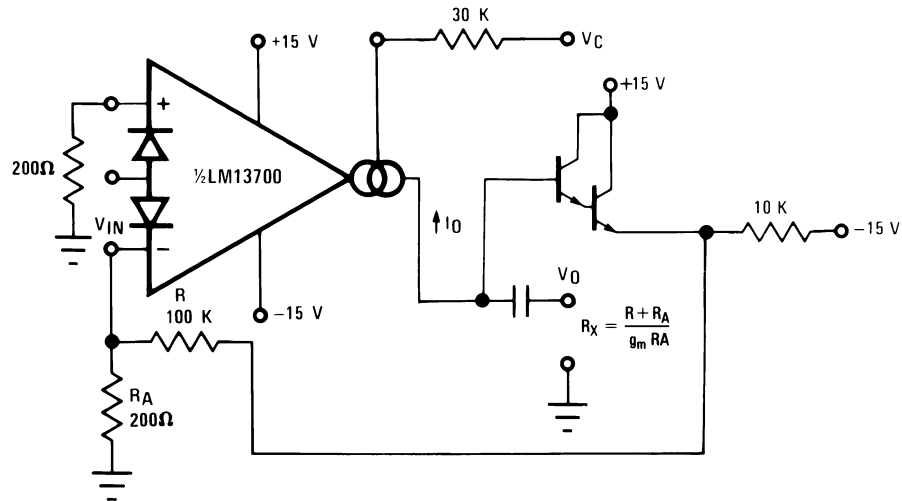

FIGURE 7. AGC Amplifier

Voltage Controlled Resistors (Continued)



00798115

FIGURE 8. Voltage Controlled Resistor, Single-Ended

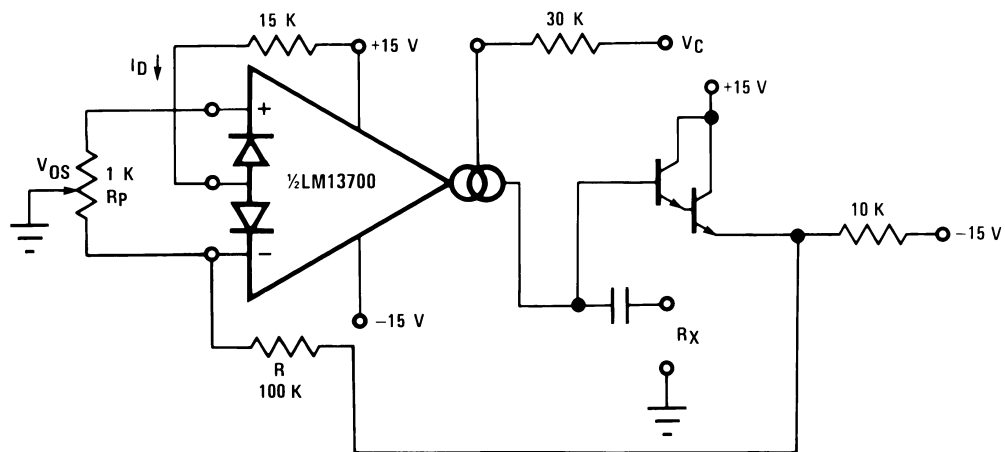

00798116

FIGURE 9. Voltage Controlled Resistor with Linearizing Diodes

Voltage Controlled Filters

OTA's are extremely useful for implementing voltage controlled filters, with the LM13700 having the advantage that the required buffers are included on the I.C. The VC Lo-Pass Filter of *Figure 11* performs as a unity-gain buffer amplifier at frequencies below cut-off, with the cut-off frequency being the point at which X_C/g_m equals the closed-loop gain of (R/R_A) . At frequencies above cut-off the circuit provides a single RC roll-off (6 dB per octave) of the input signal amplitude with a -3 dB point defined by the given equation, where

g_m is again $19.2 \times I_{ABC}$ at room temperature. *Figure 12* shows a VC High-Pass Filter which operates in much the same manner, providing a single RC roll-off below the defined cut-off frequency.

Additional amplifiers may be used to implement higher order filters as demonstrated by the two-pole Butterworth Lo-Pass Filter of *Figure 13* and the state variable filter of *Figure 14*. Due to the excellent g_m tracking of the two amplifiers, these filters perform well over several decades of frequency.

Voltage Controlled Filters (Continued)

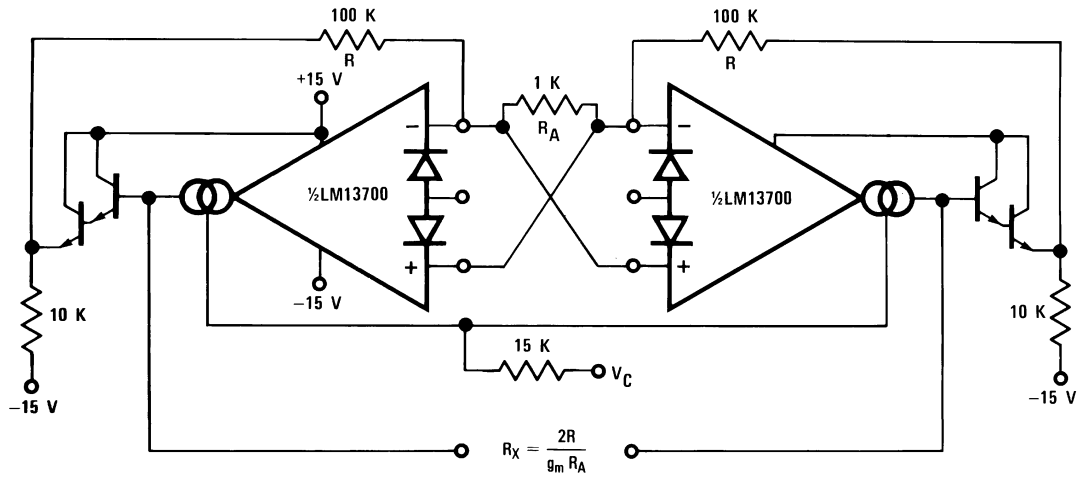

00798117

FIGURE 10. Floating Voltage Controlled Resistor

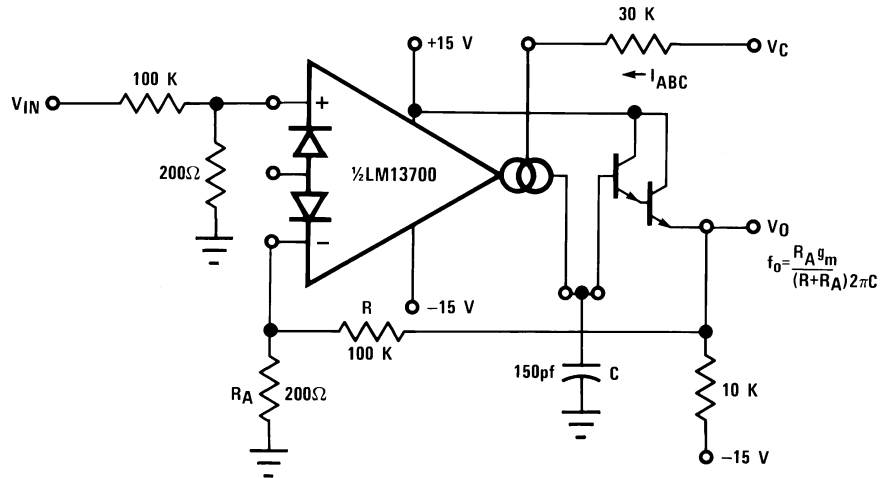

00798118

FIGURE 11. Voltage Controlled Low-Pass Filter

Voltage Controlled Filters (Continued)

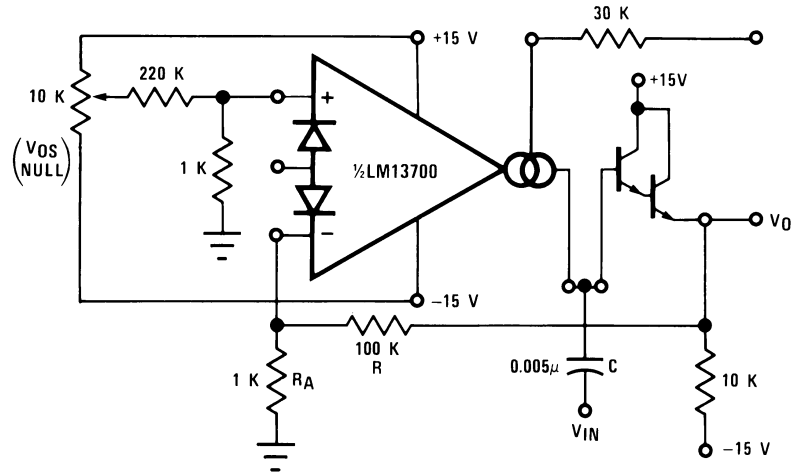

00798119

$$f_o = \frac{R_A g_m}{(R + R_A) 2\pi C}$$

FIGURE 12. Voltage Controlled Hi-Pass Filter

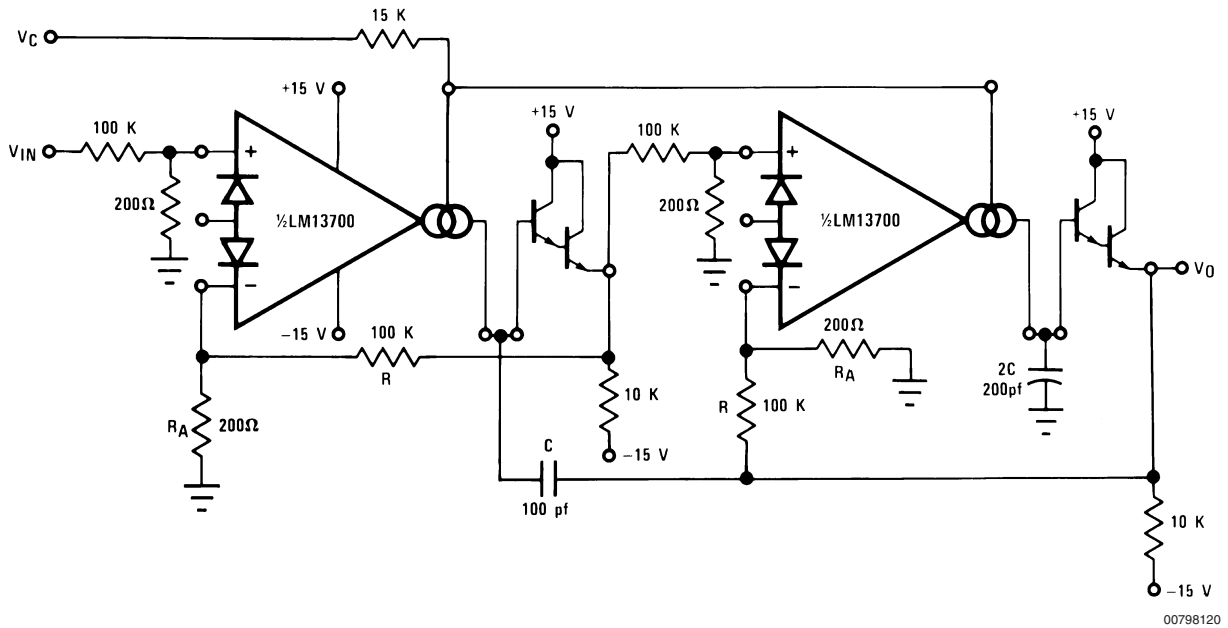

00798120

$$f_o = \frac{R_A g_m}{(R + R_A) 2\pi C}$$

FIGURE 13. Voltage Controlled 2-Pole Butterworth Lo-Pass Filter

Voltage Controlled Filters (Continued)

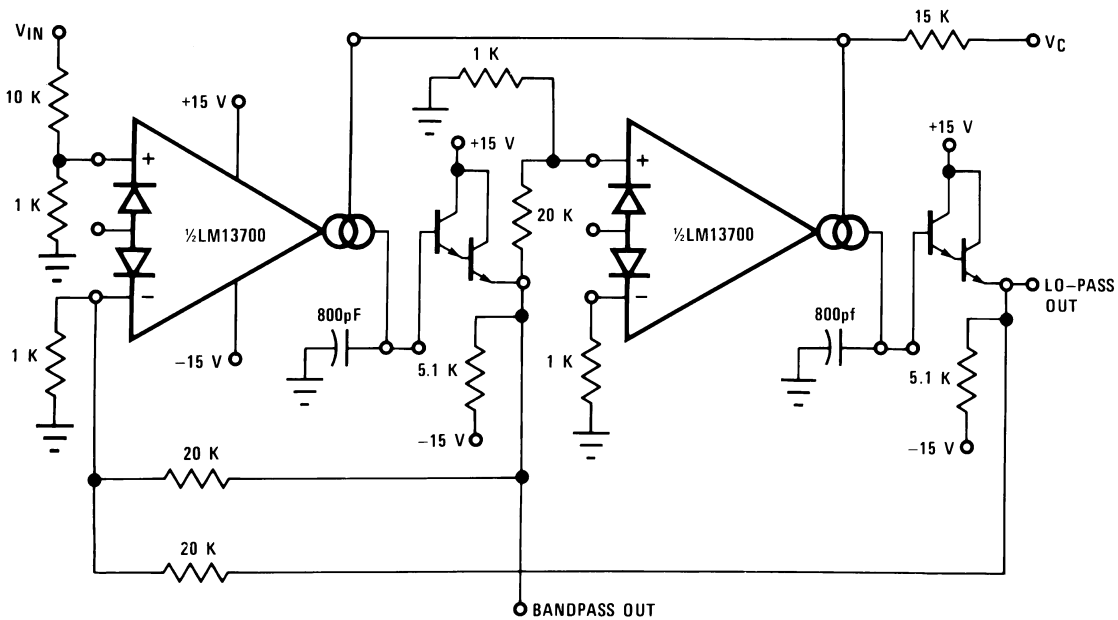

00798121

FIGURE 14. Voltage Controlled State Variable Filter

Voltage Controlled Oscillators

The classic Triangular/Square Wave VCO of Figure 15 is one of a variety of Voltage Controlled Oscillators which may be built utilizing the LM13700. With the component values shown, this oscillator provides signals from 200 kHz to below 2 Hz as I_C is varied from 1 mA to 10 nA. The output amplitudes are set by $I_A \times R_A$. Note that the peak differential input voltage must be less than 5V to prevent zenering the inputs.

A few modifications to this circuit produce the ramp/pulse VCO of Figure 16. When V_{O2} is high, I_F is added to I_C to

increase amplifier A1's bias current and thus to increase the charging rate of capacitor C. When V_{O2} is low, I_F goes to zero and the capacitor discharge current is set by I_C .

The VC Lo-Pass Filter of Figure 11 may be used to produce a high-quality sinusoidal VCO. The circuit of Figure 16 employs two LM13700 packages, with three of the amplifiers configured as lo-pass filters and the fourth as a limiter/inverter. The circuit oscillates at the frequency at which the loop phase-shift is 360° or 180° for the inverter and 60° per filter stage. This VCO operates from 5 Hz to 50 kHz with less than 1% THD.

Voltage Controlled Oscillators (Continued)

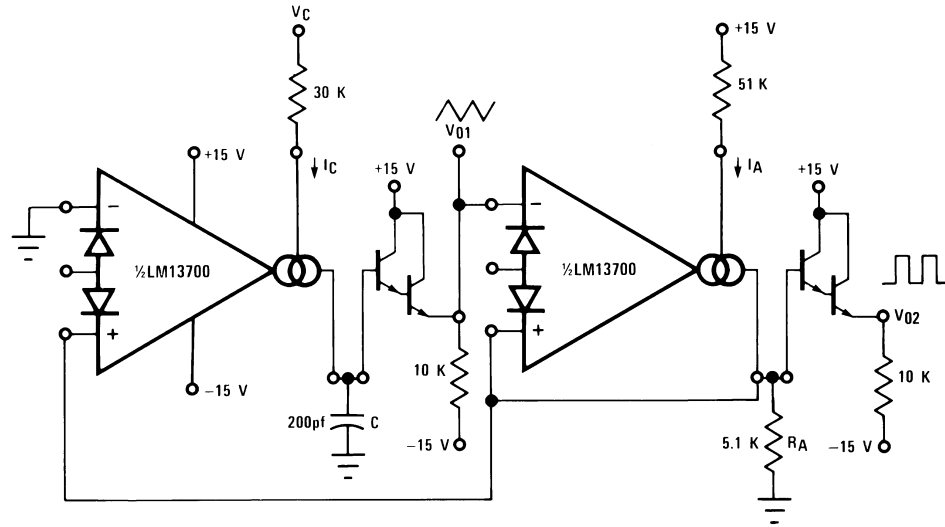

00798122

$$f_{osc} = \frac{I_C}{4C I_A R_A}$$

FIGURE 15. Triangular/Square-Wave VCO

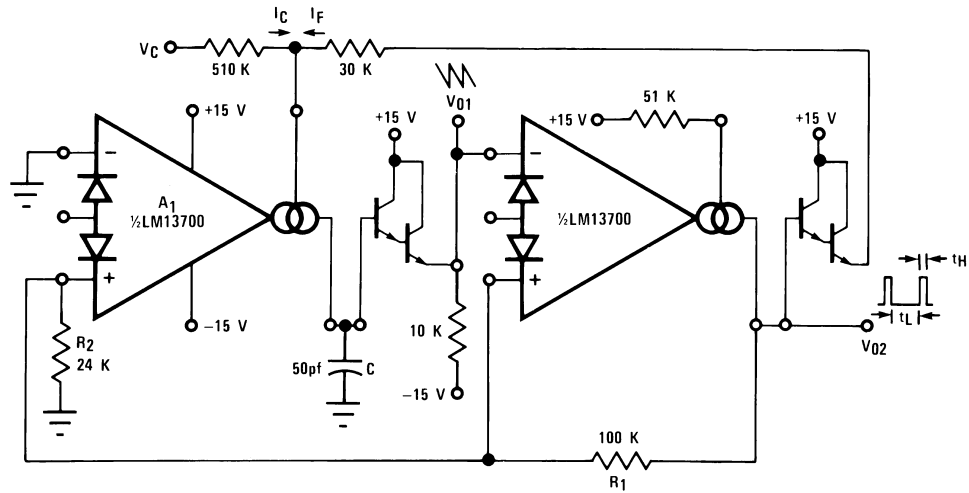

00798123

$$V_{PK} = \frac{(V^+ \pm 0.8V) R_2}{R_1 + R_2}$$

$$t_H \approx \frac{2V_{PK}C}{I_F}$$

$$t_L = \frac{2V_{PK}C}{I_C}$$

$$f_0 \approx \frac{I_C}{2V_{PK}C} \text{ for } I_C \ll I_F$$

FIGURE 16. Ramp/Pulse VCO

Voltage Controlled Oscillators (Continued)

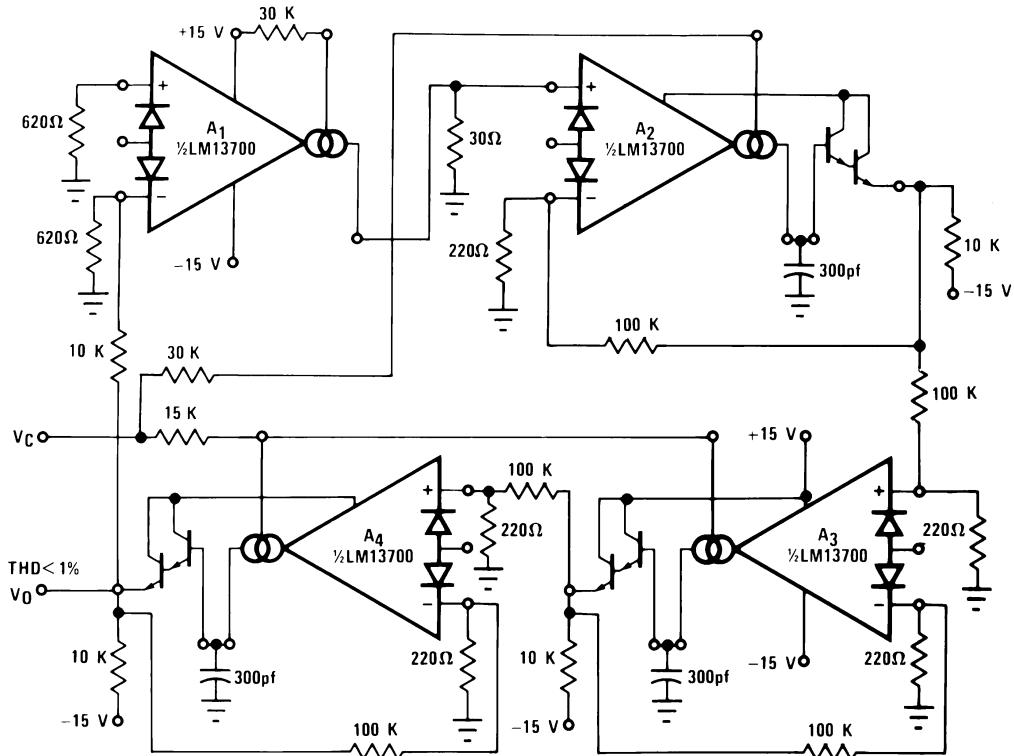

00798124

FIGURE 17. Sinusoidal VCO

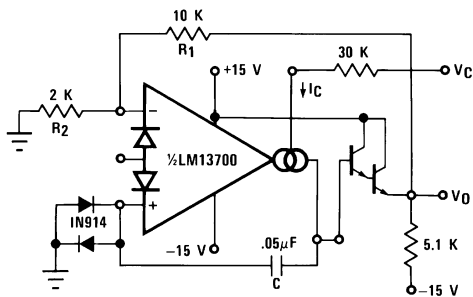

00798125

Figure 18 shows how to build a VCO using one amplifier when the other amplifier is needed for another function.

FIGURE 18. Single Amplifier VCO

Additional Applications

Figure 19 presents an interesting one-shot which draws no power supply current until it is triggered. A positive-going trigger pulse of at least 2V amplitude turns on the amplifier through R_B and pulls the non-inverting input high. The amplifier regenerates and latches its output high until capacitor C charges to the voltage level on the non-inverting input. The output then switches low, turning off the amplifier and discharging the capacitor. The capacitor discharge rate is speeded up by shorting the diode bias pin to the inverting input so that an additional discharge current flows through D_1 when the amplifier output switches low. A special feature of this timer is that the other amplifier, when biased from V_O , can perform another function and draw zero stand-by power as well.

Additional Applications (Continued)

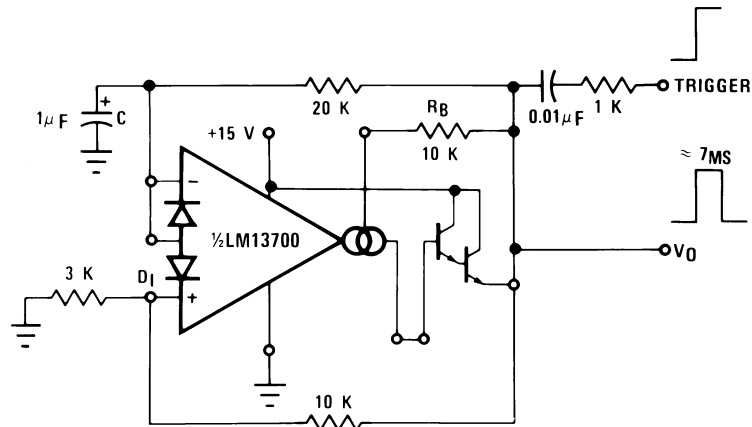

00798126

FIGURE 19. Zero Stand-By Power Timer

The operation of the multiplexer of *Figure 20* is very straightforward. When A1 is turned on it holds V_O equal to V_{IN1} and when A2 is supplied with bias current then it controls V_O . C_C and R_C serve to stabilize the unity-gain configuration of amplifiers A1 and A2. The maximum clock rate is limited to about 200 kHz by the LM13700 slew rate into 150 pF when the $(V_{IN1} - V_{IN2})$ differential is at its maximum allowable value of 5V.

The Phase-Locked Loop of *Figure 21* uses the four-quadrant multiplier of *Figure 6* and the VCO of *Figure 18* to produce a PLL with a $\pm 5\%$ hold-in range and an input sensitivity of about 300 mV.

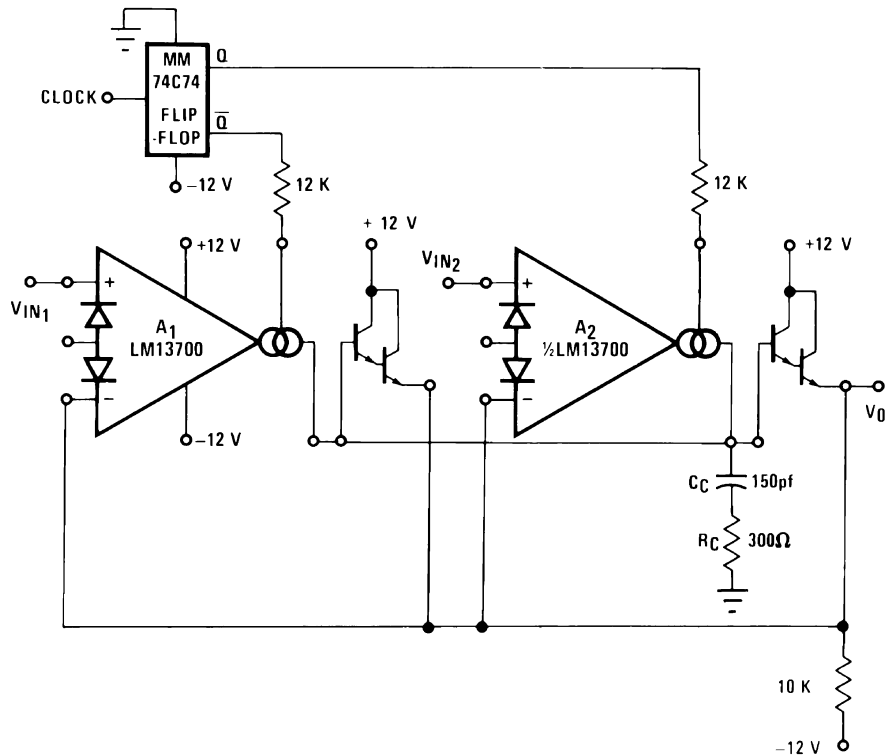

00798127

FIGURE 20. Multiplexer

Additional Applications (Continued)

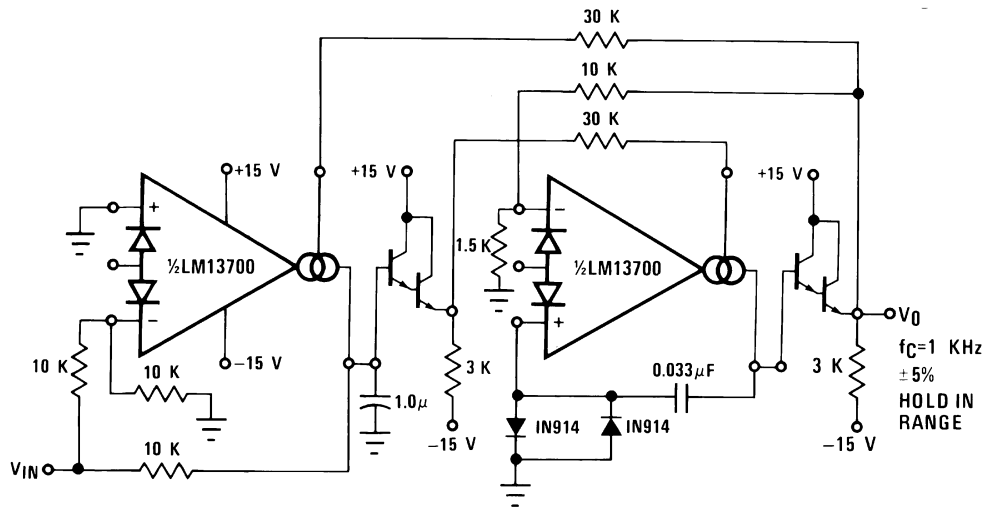

00798128

FIGURE 21. Phase Lock Loop

The Schmitt Trigger of Figure 22 uses the amplifier output current into R to set the hysteresis of the comparator; thus $V_H = 2 \times R \times I_B$. Varying I_B will produce a Schmitt Trigger with variable hysteresis.

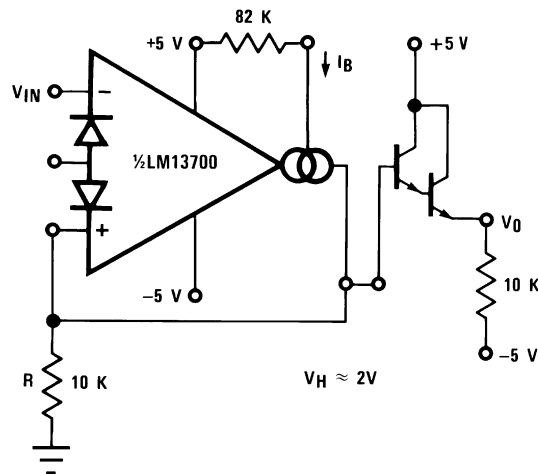

00798129

FIGURE 22. Schmitt Trigger

Figure 23 shows a Tachometer or Frequency-to-Voltage converter. Whenever A1 is toggled by a positive-going input, an amount of charge equal to $(V_H - V_L) C_t$ is sourced into C_t and R_t . This once per cycle charge is then balanced by the current of V_O/R_t . The maximum F_{IN} is limited by the amount of time required to charge C_t from V_L to V_H with a current of I_B , where V_L and V_H represent the maximum low and maximum high output voltage swing of the LM13700. D1 is added to provide a discharge path for C_t when A1 switches low.

The Peak Detector of Figure 24 uses A2 to turn on A1 whenever V_{IN} becomes more positive than V_O . A1 then charges storage capacitor C to hold V_O equal to V_{IN} PK. Pulling the output of A2 low through D1 serves to turn off A1 so that V_O remains constant.

Additional Applications (Continued)

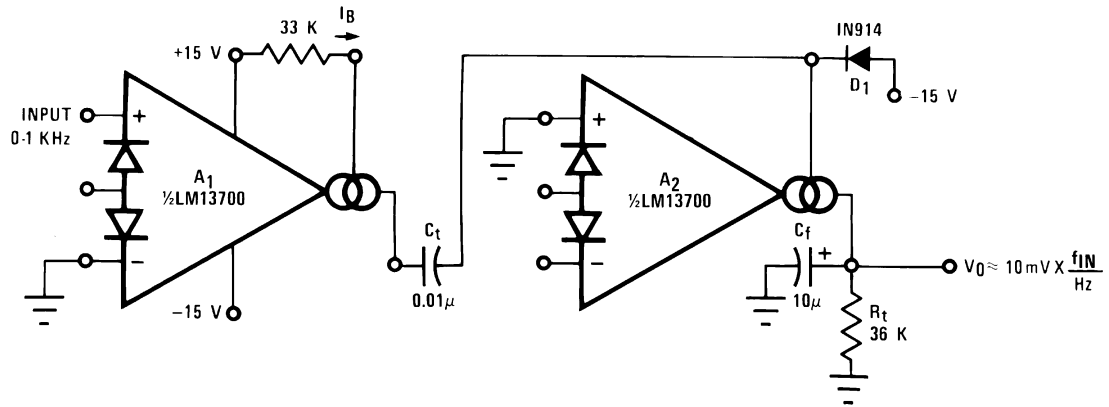

00798130

FIGURE 23. Tachometer

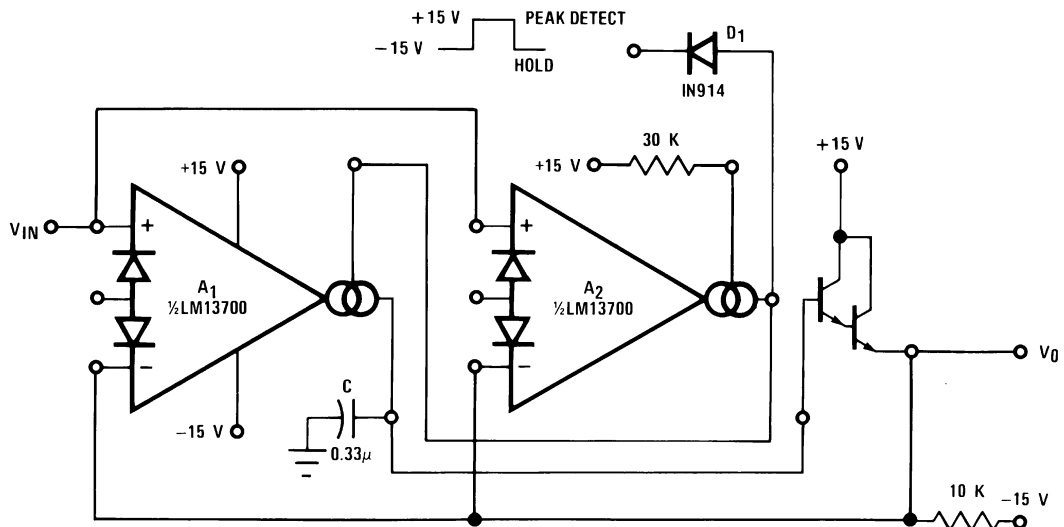

00798131

FIGURE 24. Peak Detector and Hold Circuit

The Ramp-and-Hold of Figure 26 sources I_B into capacitor C whenever the input to A1 is brought high, giving a ramp-rate of about 1V/ms for the component values shown.

The true-RMS converter of Figure 27 is essentially an automatic gain control amplifier which adjusts its gain such that the AC power at the output of amplifier A1 is constant. The output power of amplifier A1 is monitored by squaring amplifier A2 and the average compared to a reference voltage with amplifier A3. The output of A3 provides bias current to

the diodes of A1 to attenuate the input signal. Because the output power of A1 is held constant, the RMS value is constant and the attenuation is directly proportional to the RMS value of the input voltage. The attenuation is also proportional to the diode bias current. Amplifier A4 adjusts the ratio of currents through the diodes to be equal and therefore the voltage at the output of A4 is proportional to the RMS value of the input voltage. The calibration potentiometer is set such that V_O reads directly in RMS volts.

Additional Applications (Continued)

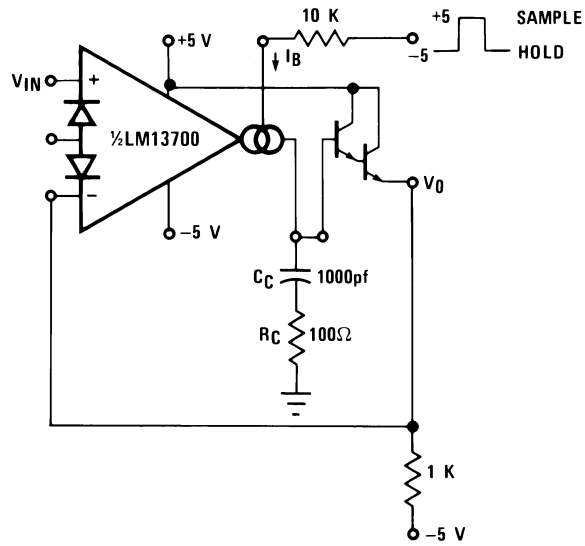

00798132

FIGURE 25. Sample-Hold Circuit

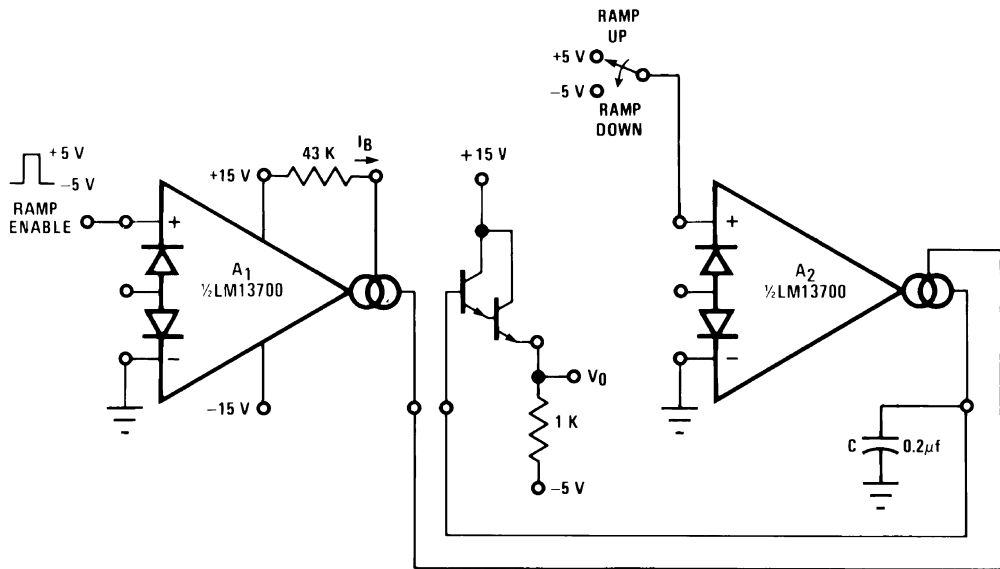

00798133

FIGURE 26. Ramp and Hold

Additional Applications (Continued)

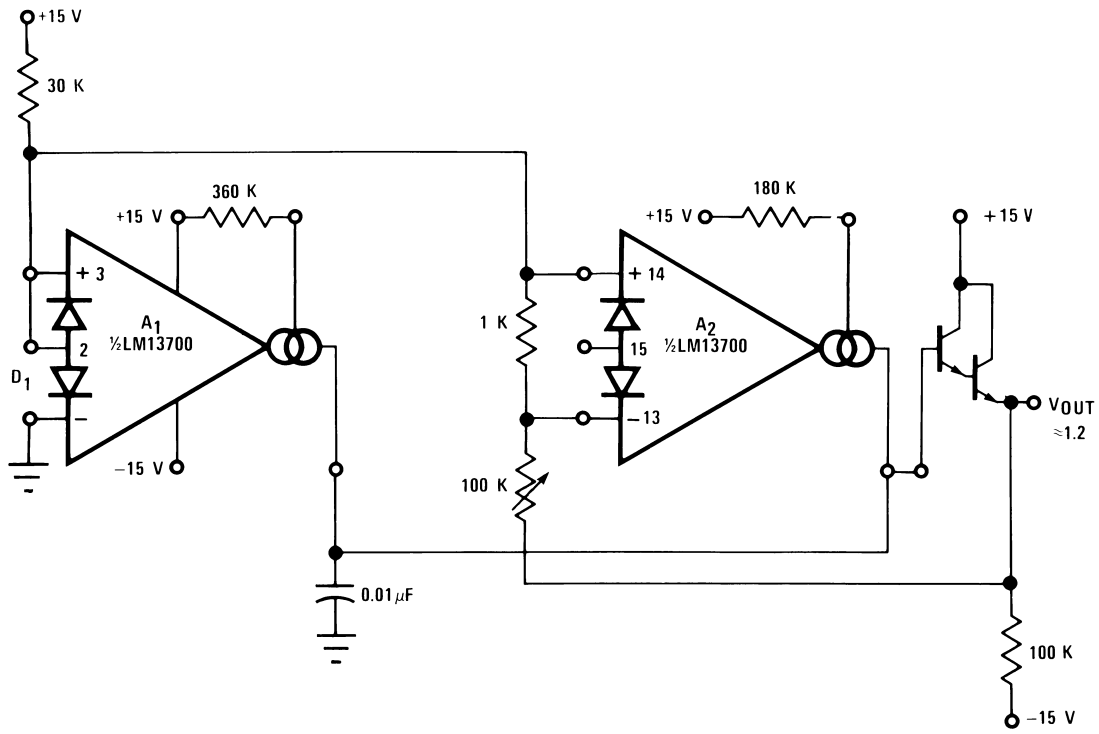

00798135

FIGURE 28. Delta VBE Reference

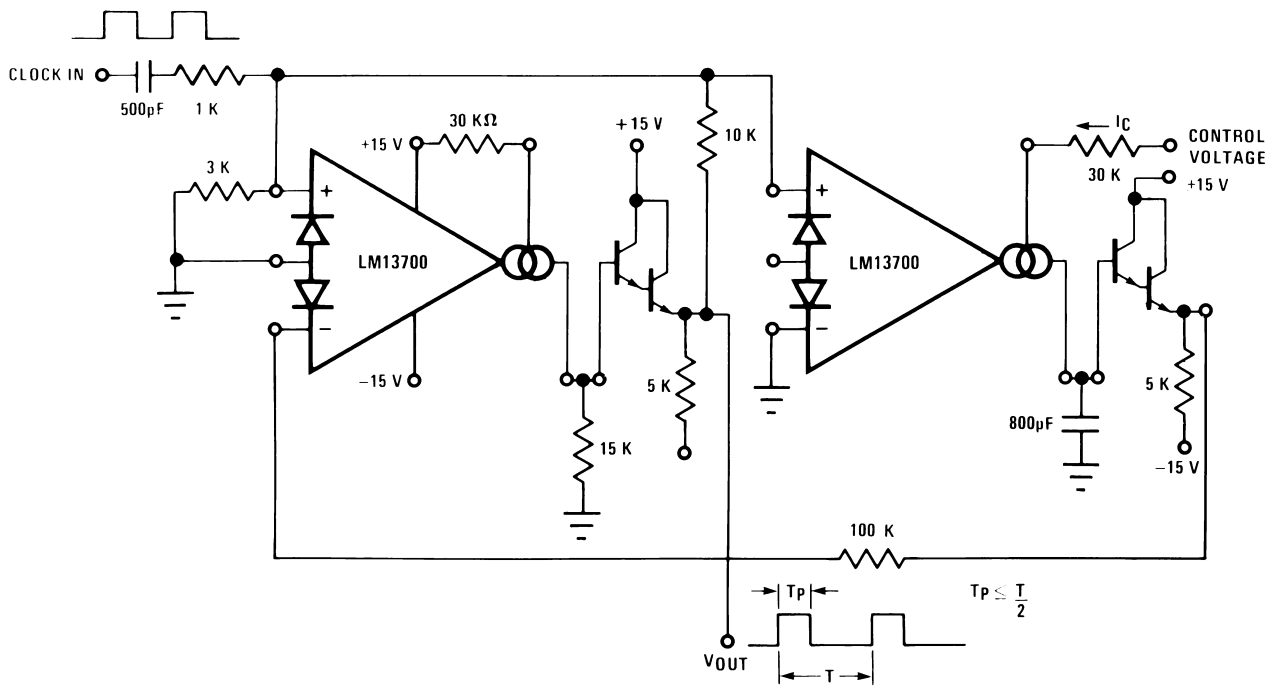

00798136

FIGURE 29. Pulse Width Modulator

Additional Applications (Continued)

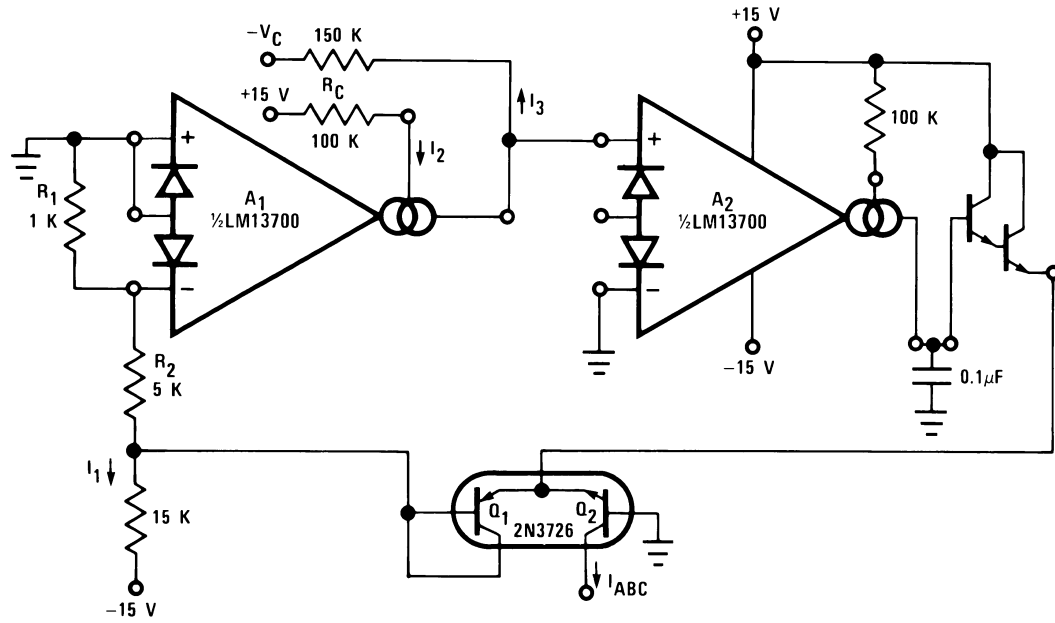

00798137

$$I_{ABC} = I_1 \exp \frac{-C I_3}{I_2}$$

FIGURE 30. Logarithmic Current Source

Physical Dimensions inches (millimeters) unless otherwise noted

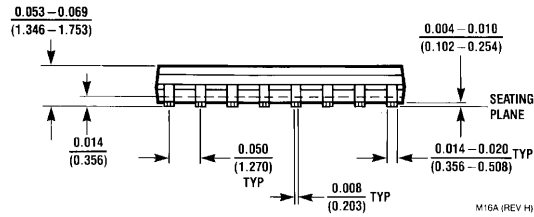
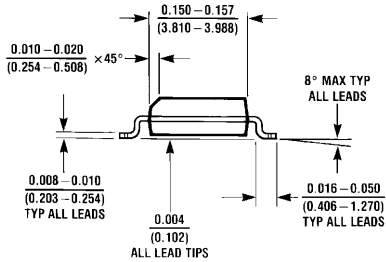
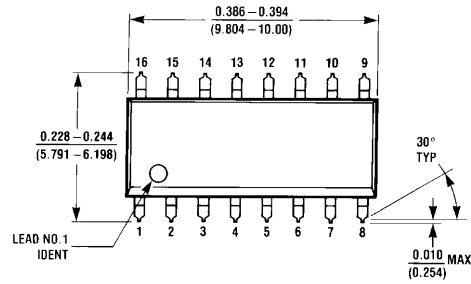

S.O. Package (M)
Order Number LM13700M or LM13700MX
NS Package Number M16A

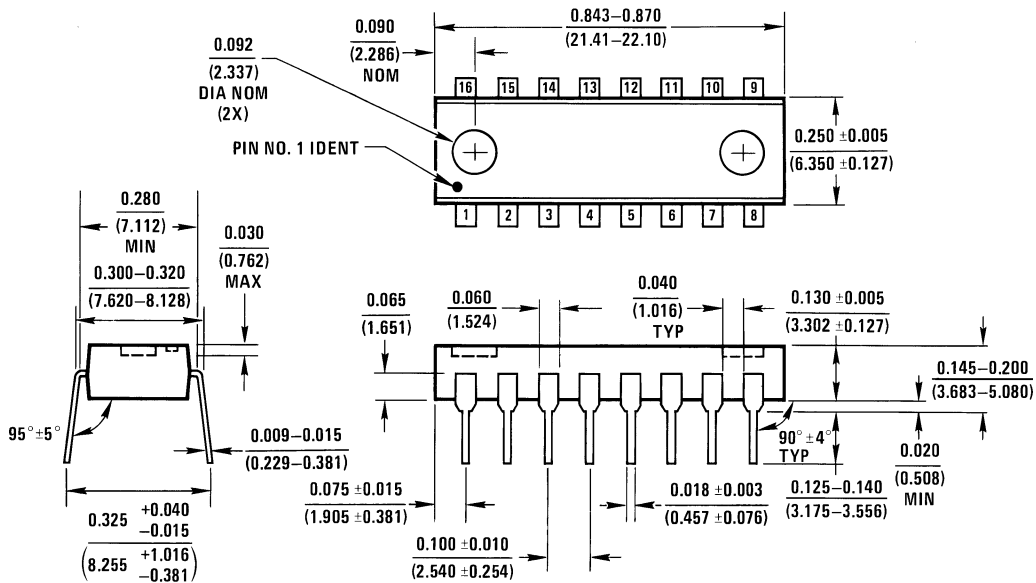

Molded Dual-In-Line Package (N)
Order Number LM13700N
NS Package Number N16A

Notes

LIFE SUPPORT POLICY

NATIONAL'S PRODUCTS ARE NOT AUTHORIZED FOR USE AS CRITICAL COMPONENTS IN LIFE SUPPORT DEVICES OR SYSTEMS WITHOUT THE EXPRESS WRITTEN APPROVAL OF THE PRESIDENT AND GENERAL COUNSEL OF NATIONAL SEMICONDUCTOR CORPORATION. As used herein:

1. Life support devices or systems are devices or systems which, (a) are intended for surgical implant into the body, or (b) support or sustain life, and whose failure to perform when properly used in accordance with instructions for use provided in the labeling, can be reasonably expected to result in a significant injury to the user.
2. A critical component is any component of a life support device or system whose failure to perform can be reasonably expected to cause the failure of the life support device or system, or to affect its safety or effectiveness.

BANNED SUBSTANCE COMPLIANCE

National Semiconductor certifies that the products and packing materials meet the provisions of the Customer Products Stewardship Specification (CSP-9-111C2) and the Banned Substances and Materials of Interest Specification (CSP-9-111S2) and contain no "Banned Substances" as defined in CSP-9-111S2.



National Semiconductor
Americas Customer
Support Center
 Email: new.feedback@nsc.com
 Tel: 1-800-272-9959

www.national.com

National Semiconductor
Europe Customer Support Center
 Fax: +49 (0) 180-530 85 86
 Email: europe.support@nsc.com
 Deutsch Tel: +49 (0) 69 9508 6208
 English Tel: +44 (0) 870 24 0 2171
 Français Tel: +33 (0) 1 41 91 8790

National Semiconductor
Asia Pacific Customer
Support Center
 Email: ap.support@nsc.com

National Semiconductor
Japan Customer Support Center
 Fax: 81-3-5639-7507
 Email: jpn.feedback@nsc.com
 Tel: 81-3-5639-7560