

LM2901EP

Low Power Low Offset Voltage Quad Comparators

General Description

The LM2901EP consists of four independent precision voltage comparators with an offset voltage specification as low as 2 mV max for all four comparators. These were designed specifically to operate from a single power supply over a wide range of voltages. Operation from split power supplies is also possible and the low power supply current drain is independent of the magnitude of the power supply voltage. This comparator also has a unique characteristic in that the input common-mode voltage range includes ground, even though operated from a single power supply voltage.

Application areas include limit comparators, simple analog to digital converters; pulse, squarewave and time delay generators; wide range VCO; MOS clock timers; multivibrators and high voltage digital logic gates. The LM2901EP was designed to directly interface with TTL and CMOS. When operated from both plus and minus power supplies, it will directly interface with MOS logic— where the low power drain of the LM2901EP is a distinct advantage over standard comparators.

ENHANCED PLASTIC

- Extended Temperature Performance of -40°C to $+85^{\circ}\text{C}$
- Baseline Control - Single Fab & Assembly Site
- Process Change Notification (PCN)
- Qualification & Reliability Data
- Solder (PbSn) Lead Finish is standard
- Enhanced Diminishing Manufacturing Sources (DMS) Support

Features

- Wide supply voltage range
- LM2901: 2 to $36 V_{\text{DC}}$ or ± 1 to $\pm 18 V_{\text{DC}}$
- Very low supply current drain (0.8 mA) — independent of supply voltage
- Low input biasing current: 25 nA
- Low input offset current: $\pm 5 \text{ nA}$
- Offset voltage: $\pm 3 \text{ mV}$
- Input common-mode voltage range includes GND
- Differential input voltage range equal to the power supply voltage
- Low output saturation voltage: 250 mV at 4 mA
- Output voltage compatible with TTL, DTL, ECL, MOS and CMOS logic systems

Advantages

- High precision comparator
- Reduced V_{OS} drift over temperature
- Eliminates need for dual supplies
- Allows sensing near GND
- Compatible with all forms of logic
- Power drain suitable for battery operation

Applications

- Selected Military Applications
- Selected Avionics Applications

Ordering Information

| PART NUMBER | VID PART NUMBER | NS PACKAGE NUMBER (Note 3) |
|--------------|-----------------|----------------------------|
| LM2901MEP | V62/04743-01 | M14A |
| (Notes 1, 2) | TBD | TBD |

Note 1: For the following (Enhanced Plastic) version, check for availability: - LM2901MXEP, LM2901NEP. Parts listed with an "X" are provided in Tape & Reel and parts without an "X" are in Rails.

Note 2: FOR ADDITIONAL ORDERING AND PRODUCT INFORMATION, PLEASE VISIT THE ENHANCED PLASTIC WEB SITE AT: www.national.com/mil

Note 3: Refer to package details under Physical Dimensions

One-Shot Multivibrator with Input Lock Out

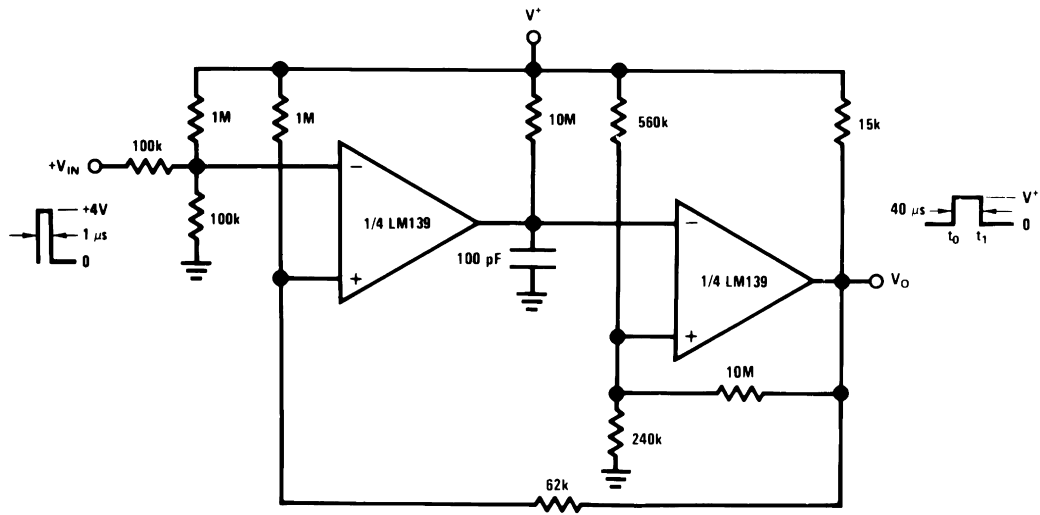

20113912

Absolute Maximum Ratings (Note 4)

If Military/Aerospace specified devices are required, please contact the National Semiconductor Sales Office/Distributors for availability and specifications.

| | |
|---|---|
| Supply Voltage, V^+ | $36 V_{DC}$ or $\pm 18 V_{DC}$ |
| Differential Input Voltage (Note 12) | $36 V_{DC}$ |
| Input Voltage | $-0.3 V_{DC}$ to $+36 V_{DC}$ |
| Input Current ($V_{IN} < -0.3 V_{DC}$), (Note 7) | 50 mA |
| Power Dissipation (Note 5) | |
| Molded DIP | 1050 mW |
| Small Outline Package | 760 mW |
| Output Short-Circuit to GND, (Note 6) | Continuous |
| Storage Temperature Range | -65°C to $+150^{\circ}\text{C}$ |
| Lead Temperature (Soldering, 10 seconds) | 260°C |
| Operating Temperature Range LM2901 | -40°C to $+85^{\circ}\text{C}$ |
| Soldering Information | |
| Dual-In-Line Package | |
| Soldering (10 seconds) | 260°C |
| Small Outline Package | |
| Vapor Phase (60 seconds) | 215°C |
| Infrared (15 seconds) | 220°C |
| ESD rating (1.5 k Ω in series with 100 pF) | 600V |

Electrical Characteristics (Note 14)

($V^+ = 5 V_{DC}$, $T_A = 25^{\circ}\text{C}$, unless otherwise stated)

| Parameter | Conditions | LM2901 | | | Units |
|---------------------------------|---|--------|-----|-------------|------------------|
| | | Min | Typ | Max | |
| Input Offset Voltage | (Note 13) | | 2.0 | 7.0 | mV_{DC} |
| Input Bias Current | $I_{IN(+)}$ or $I_{IN(-)}$ with Output in Linear Range, (Note 9), $V_{CM}=0V$ | | 25 | 250 | nA_{DC} |
| Input Offset Current | $I_{IN(+)} - I_{IN(-)}$, $V_{CM} = 0V$ | | 5 | 50 | nA_{DC} |
| Input Common-Mode Voltage Range | $V^+ = 30 V_{DC}$ (Note 10) | 0 | | $V^+ - 1.5$ | V_{DC} |
| Supply Current | $R_L = \infty$ on all Comparators, $R_L = \infty$, $V^+ = 36V$, | | 0.8 | 2.0 | mA_{DC} |
| Voltage Gain | $R_L \geq 15 \text{ k}\Omega$, $V^+ = 15 V_{DC}$ $V_O = 1 V_{DC}$ to $11 V_{DC}$ | 25 | 100 | 2.5 | V/mV |
| Large Signal Response Time | $V_{IN} = \text{TTL Logic Swing}$, $V_{REF} = 1.4 V_{DC}$, $V_{RL} = 5 V_{DC}$, $R_L = 5.1 \text{ k}\Omega$, | | 300 | | ns |
| Response Time | $V_{RL} = 5 V_{DC}$, $R_L = 5.1 \text{ k}\Omega$, (Note 11) | | 1.3 | | μs |
| Output Sink Current | $V_{IN(-)} = 1 V_{DC}$, $V_{IN(+)} = 0$, $V_O \leq 1.5 V_{DC}$ | 6.0 | 16 | | mA_{DC} |
| Saturation Voltage | $V_{IN(-)} = 1 V_{DC}$, $V_{IN(+)} = 0$, $I_{SINK} \leq 4 \text{ mA}$ | | 250 | 400 | mV_{DC} |
| Output Leakage Current | $V_{IN(+)} = 1 V_{DC}$, $V_{IN(-)} = 0$, $V_O = 5 V_{DC}$ | | 0.1 | | nA_{DC} |

Electrical Characteristics (Note 14)

($V^+ = 5.0 V_{DC}$) (Note 8)

| Parameter | Conditions | LM2901 | | | Units |
|---------------------------------|--|--------|-----|-------------|--------------|
| | | Min | Typ | Max | |
| Input Offset Voltage | (Note 13) | | 9 | 15 | mV_{DC} |
| Input Offset Current | $I_{IN(+)} - I_{IN(-)}$, $V_{CM} = 0V$ | | 50 | 200 | nA_{DC} |
| Input Bias Current | $I_{IN(+)}$ or $I_{IN(-)}$ with Output in Linear Range, $V_{CM} = 0V$ (Note 9) | | 200 | 500 | nA_{DC} |
| Input Common-Mode Voltage Range | $V^+ = 30 V_{DC}$ (Note 10) | 0 | | $V^+ - 2.0$ | V_{DC} |
| Saturation Voltage | $V_{IN(-)} = 1 V_{DC}$, $V_{IN(+)} = 0$, $I_{SINK} \leq 4 mA$ | | 400 | 700 | mV_{DC} |
| Output Leakage Current | $V_{IN(+)} = 1 V_{DC}$, $V_{IN(-)} = 0$, $V_O = 30 V_{DC}$ | | | 1.0 | μA_{DC} |
| Differential Input Voltage | Keep all V_{IN} 's $\geq 0 V_{DC}$ (or V^- , if used), (Note 12) | | | 36 | V_{DC} |

Note 4: Absolute Maximum Ratings indicate limits beyond which damage to the device may occur.

Note 5: For operating at high temperatures, the LM2901EP must be derated based on a 125°C maximum junction temperature and a thermal resistance of 95°C/W which applies for the device soldered in a printed circuit board, operating in a still air ambient. The low bias dissipation and the "ON-OFF" characteristic of the outputs keeps the chip dissipation very small ($P_D \leq 100 mW$), provided the output transistors are allowed to saturate.

Note 6: Short circuits from the output to V^+ can cause excessive heating and eventual destruction. When considering short circuits to ground, the maximum output current is approximately 20 mA independent of the magnitude of V^+ .

Note 7: This input current will only exist when the voltage at any of the input leads is driven negative. It is due to the collector-base junction of the input PNP transistors becoming forward biased and thereby acting as input diode clamps. In addition to this diode action, there is also lateral NPN parasitic transistor action on the IC chip. This transistor action can cause the output voltages of the comparators to go to the V^+ voltage level (or to ground for a large overdrive) for the time duration that an input is driven negative. This is not destructive and normal output states will re-establish when the input voltage, which was negative, again returns to a value greater than $-0.3 V_{DC}$ (at 25°C).

Note 8: These specifications are limited to $-40^\circ C \leq T_A \leq +85^\circ C$, for the LM2901EP.

Note 9: The direction of the input current is out of the IC due to the PNP input stage. This current is essentially constant, independent of the state of the output so no loading change exists on the reference or input lines.

Note 10: The input common-mode voltage or either input signal voltage should not be allowed to go negative by more than 0.3V. The upper end of the common-mode voltage range is $V^+ - 1.5V$ at 25°C, but either or both inputs can go to $+30 V_{DC}$ without damage independent of the magnitude of V^+ .

Note 11: The response time specified is a 100 mV input step with 5 mV overdrive. For larger overdrive signals 300 ns can be obtained, see typical performance characteristics section.

Note 12: Positive excursions of input voltage may exceed the power supply level. As long as the other voltage remains within the common-mode range, the comparator will provide a proper output state. The low input voltage state must not be less than $-0.3 V_{DC}$ (or $0.3 V_{DC}$ below the magnitude of the negative power supply, if used) (at 25°C).

Note 13: At output switch point, $V_O = 1.4 V_{DC}$, $R_S = 0 \Omega$ with V^+ from $5 V_{DC}$ to $30 V_{DC}$; and over the full input common-mode range ($0 V_{DC}$ to $V^+ - 1.5 V_{DC}$), at 25°C.

Note 14: "Testing and other quality control techniques are used to the extent deemed necessary to ensure product performance over the specified temperature range. Product may not necessarily be tested across the full temperature range and all parameters may not necessarily be tested. In the absence of specific PARAMETRIC testing, product performance is assured by characterization and/or design."

Note 15: The LM139 within this data sheet's graphics is referenced because of its similarity to the LM2901, however is not offered in this data sheet.

Typical Performance Characteristics

Supply Current

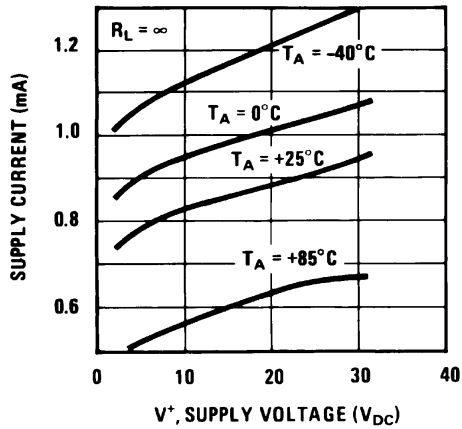

20113939

Input Current

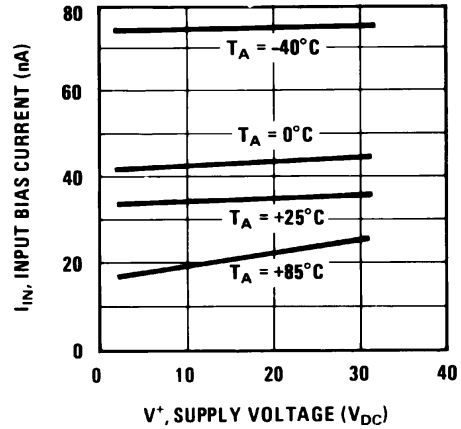

20113940

Output Saturation Voltage

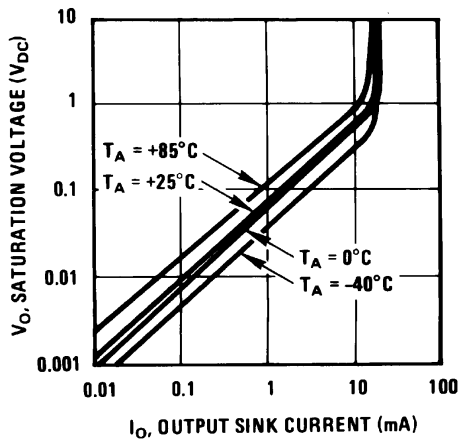

20113941

Response Time for Various Input Overdrives — Negative Transition

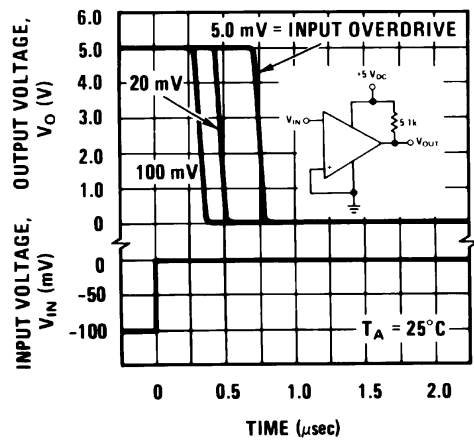

20113942

Response Time for Various Input Overdrives — Positive Transition

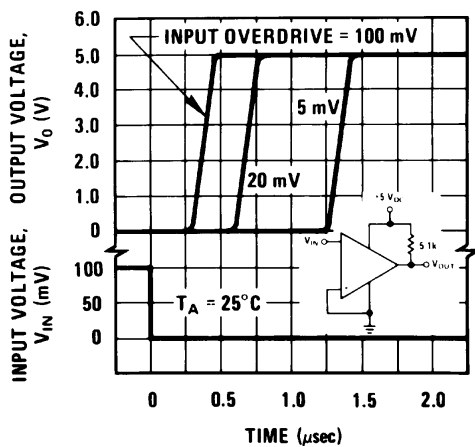

20113943

Application Hints

The LM2901EP is a high gain, wide bandwidth device which, like most comparators, can easily oscillate if the output lead is inadvertently allowed to capacitively couple to the inputs via stray capacitance. This shows up only during the output voltage transition intervals as the comparator changes states. Power supply bypassing is not required to solve this problem. Standard PC board layout is helpful as it reduces stray input-output coupling. Reducing this input resistors to $< 10\text{ k}\Omega$ reduces the feedback signal levels and finally, adding even a small amount (1 to 10 mV) of positive feedback (hysteresis) causes such a rapid transition that oscillations due to stray feedback are not possible. Simply socketing the IC and attaching resistors to the pins will cause input-output oscillations during the small transition intervals unless hysteresis is used. If the input signal is a pulse waveform, with relatively fast rise and fall times, hysteresis is not required.

All pins of any unused comparators should be tied to the negative supply.

The bias network of the LM2901EP series establishes a drain current which is independent of the magnitude of the power supply voltage over the range of from 2 V_{DC} to 30 V_{DC} .

It is usually unnecessary to use a bypass capacitor across the power supply line.

The differential input voltage may be larger than V^+ without damaging the device. Protection should be provided to prevent the input voltages from going negative more than $-0.3\text{ V}_{\text{DC}}$ (at 25°C). An input clamp diode can be used as shown in the applications section.

The output of the LM2901EP is the uncommitted collector of a grounded-emitter NPN output transistor. Many collectors can be tied together to provide an output OR'ing function. An output pull-up resistor can be connected to any available power supply voltage within the permitted supply voltage range and there is no restriction on this voltage due to the magnitude of the voltage which is applied to the V^+ terminal of the LM2901EP package. The output can also be used as a simple SPST switch to ground (when a pull-up resistor is not used). The amount of current which the output device can sink is limited by the drive available (which is independent of V^+) and the β of this device. When the maximum current limit is reached (approximately 16 mA), the output transistor will come out of saturation and the output voltage will rise very rapidly. The output saturation voltage is limited by the approximately $60\Omega R_{\text{SAT}}$ of the output transistor. The low offset voltage of the output transistor (1 mV) allows the output to clamp essentially to ground level for small load currents.

Typical Applications $(V^+ = 5.0\text{ V}_{\text{DC}})$ (Note 15)

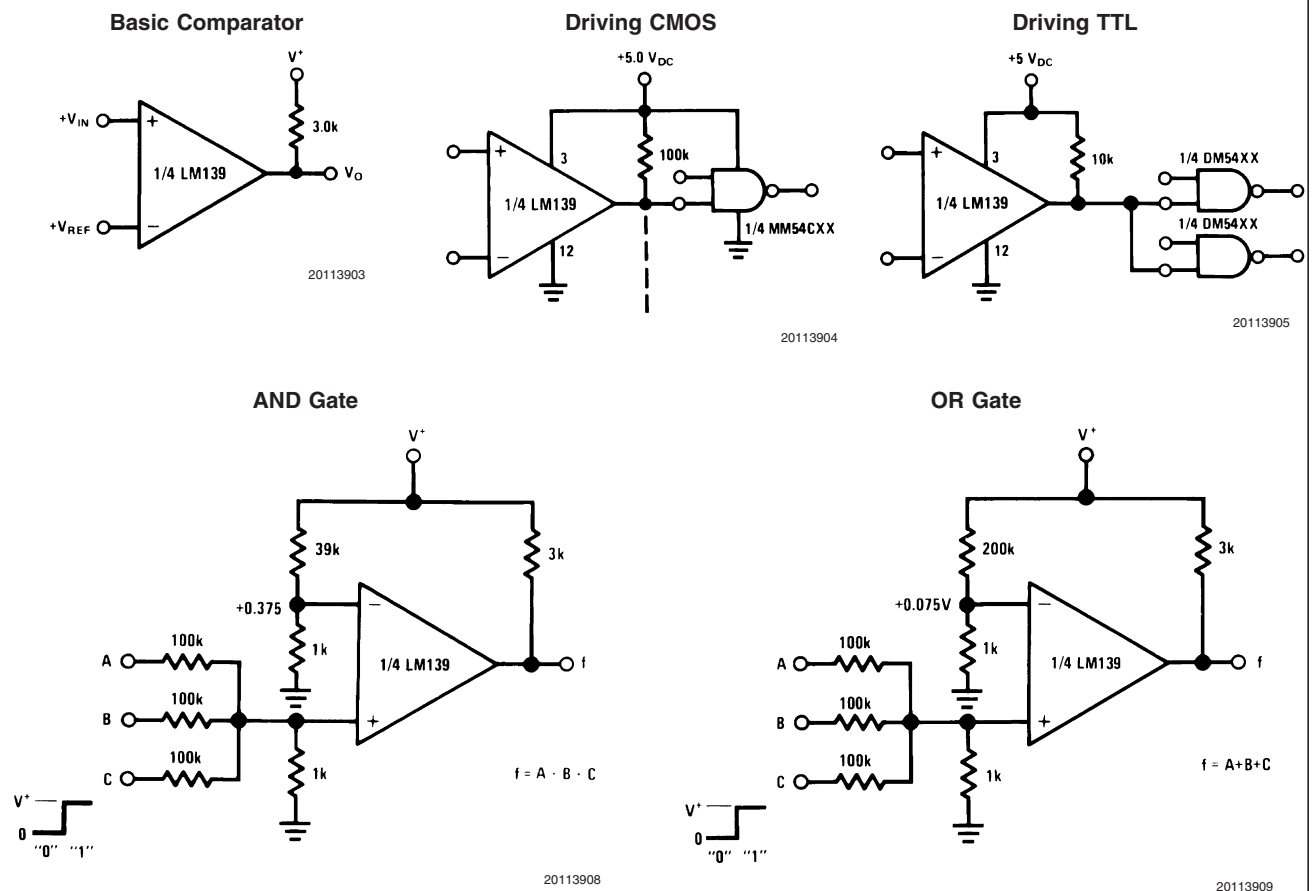

Typical Applications ($V^+ = 15\text{ V}_{\text{DC}}$) (Note 15)

One-Shot Multivibrator

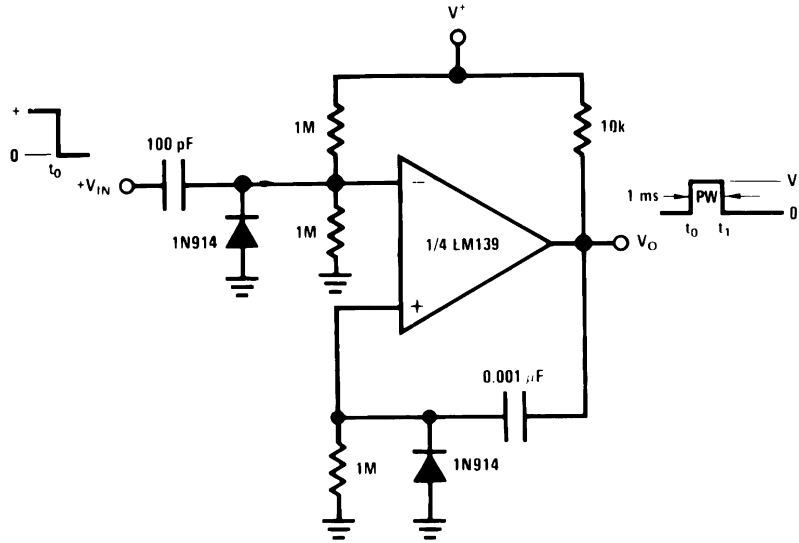

20113910

Bi-Stable Multivibrator

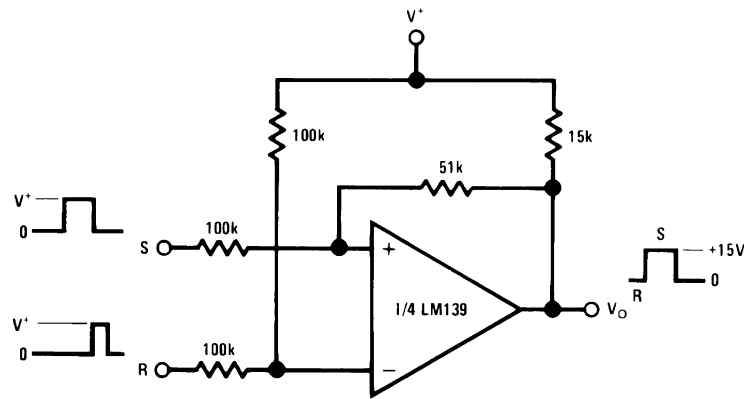

20113911

Typical Applications ($V^+ = 15\text{ V}_{\text{DC}}$) (Note 15) (Continued)

One-Shot Multivibrator with Input Lock Out

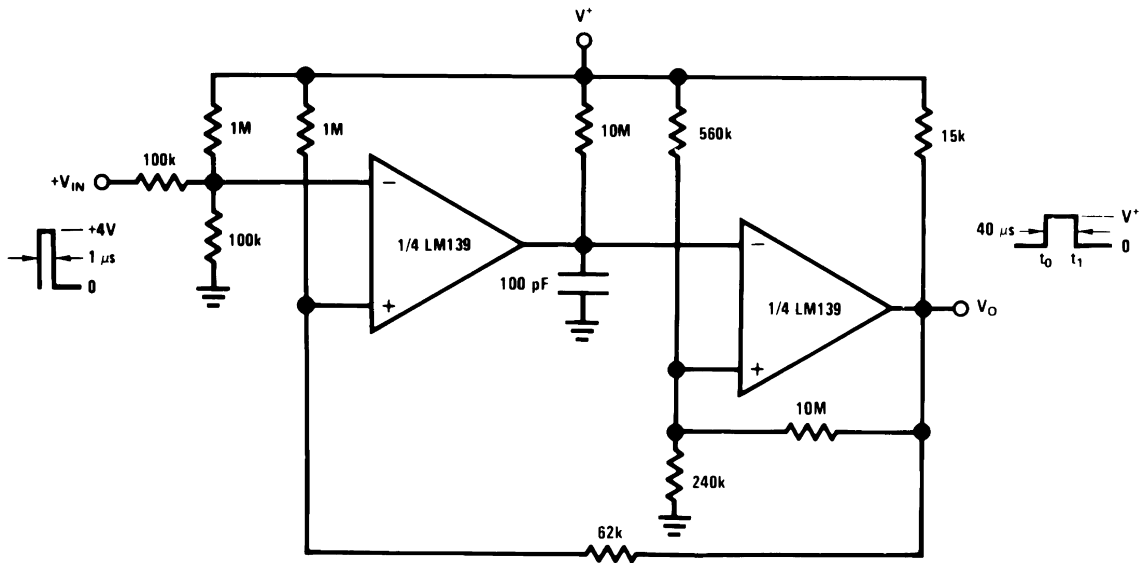

20113912

Pulse Generator

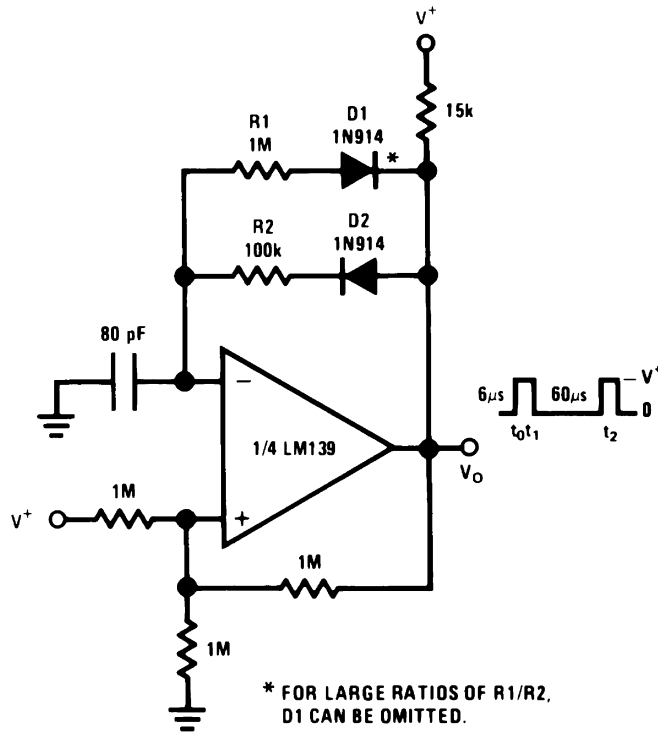

20113917

Typical Applications ($V^+ = 15\text{ V}_{DC}$) (Note 15) (Continued)

Large Fan-In AND Gate

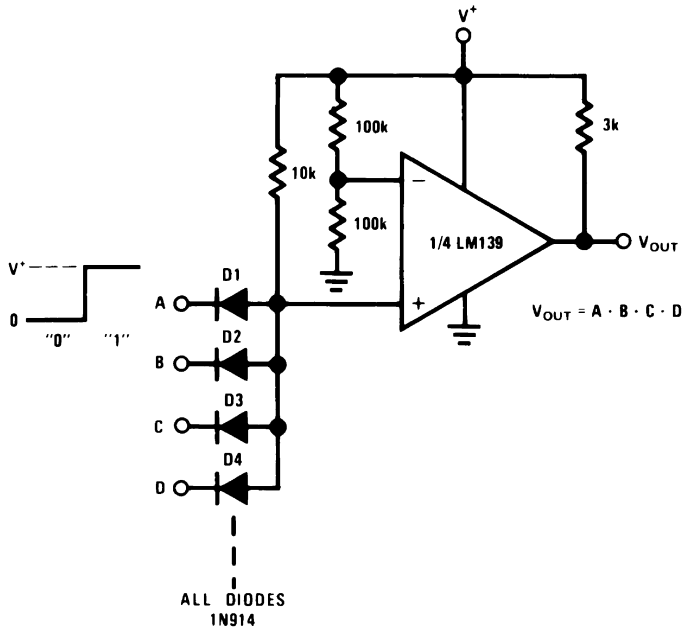

20113913

ORing the Outputs

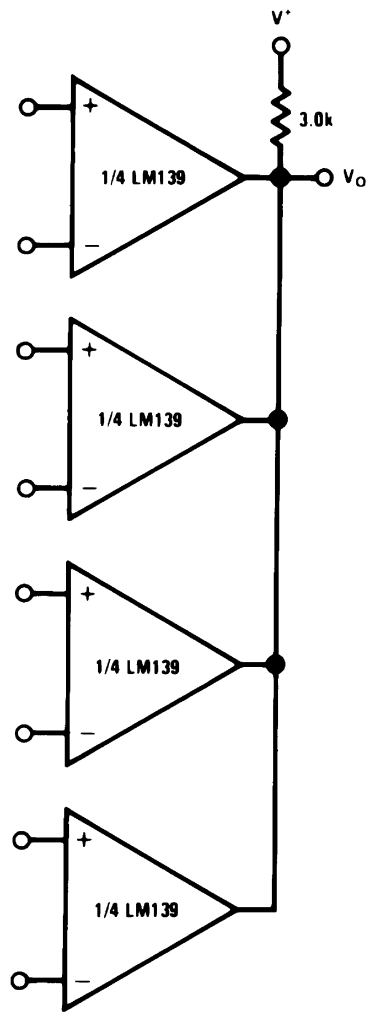

20113915

Typical Applications ($V^+ = 15 V_{DC}$) (Note 15) (Continued)

Time Delay Generator

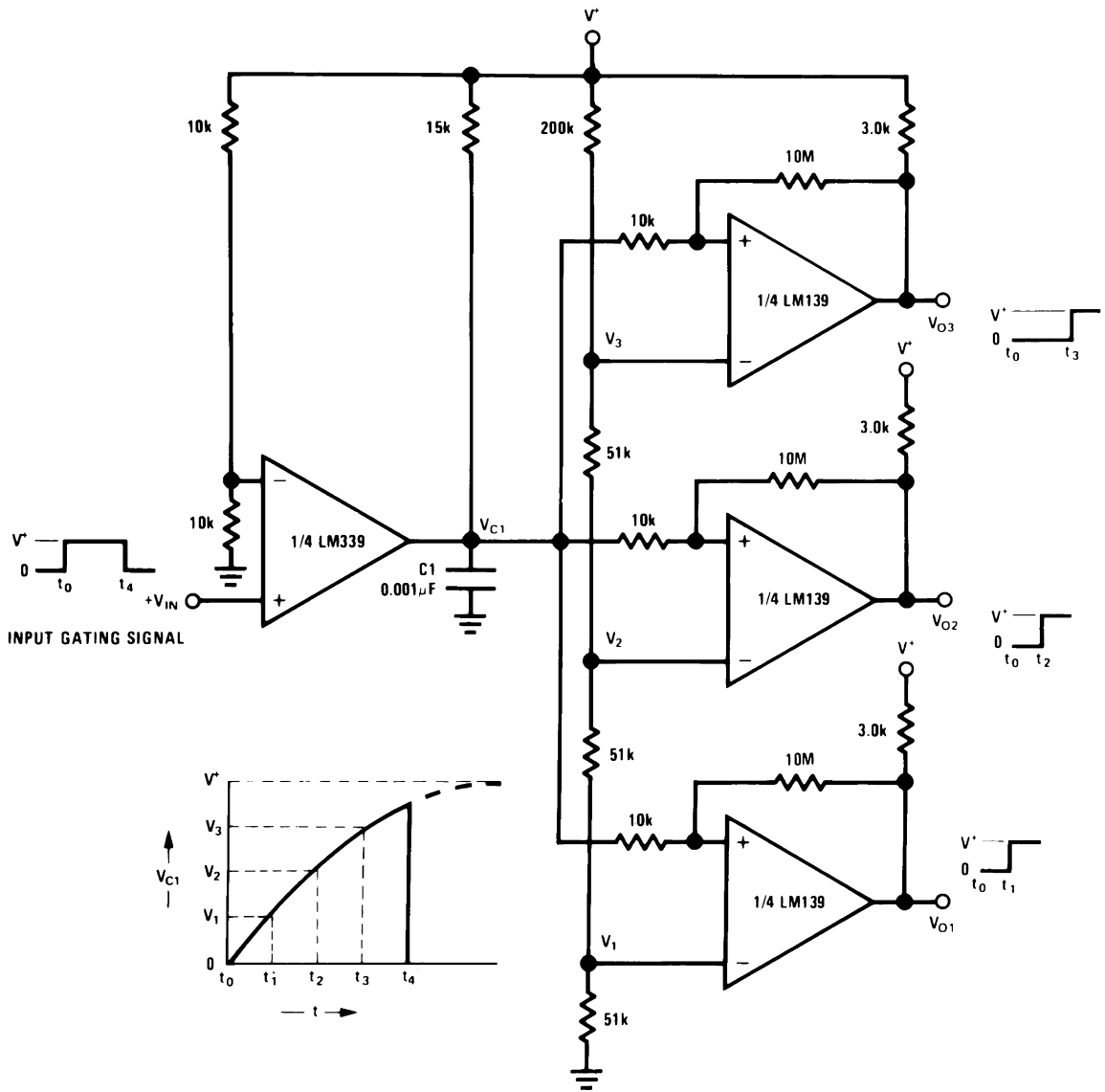

20113914

Non-Inverting Comparator with Hysteresis

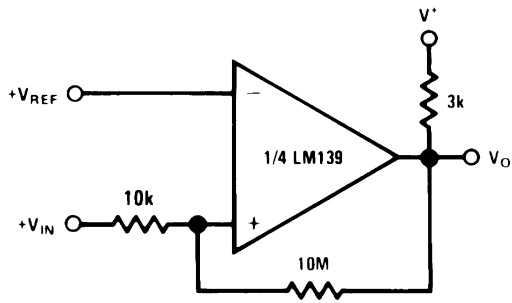

20113918

Inverting Comparator with Hysteresis

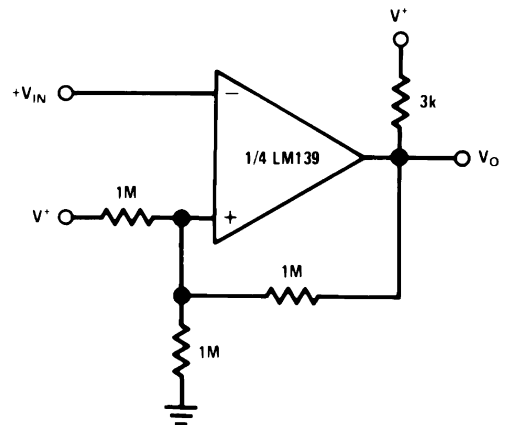

20113919

Typical Applications ($V^+ = 15\text{ V}_{DC}$) (Note 15) (Continued)

Squarewave Oscillator

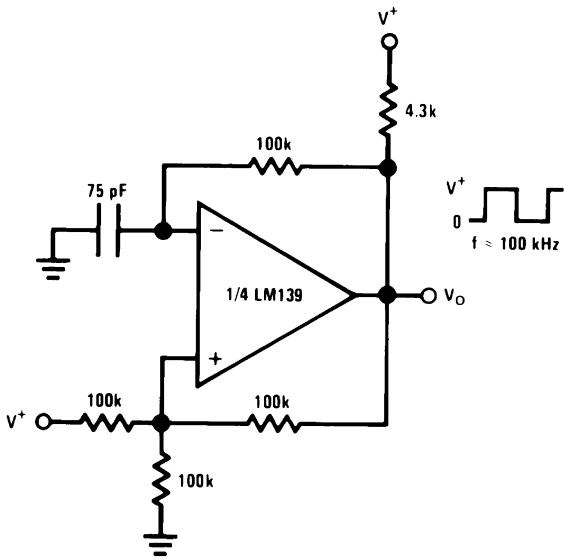

20113916

Basic Comparator

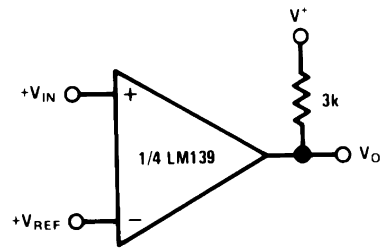

20113921

Limit Comparator

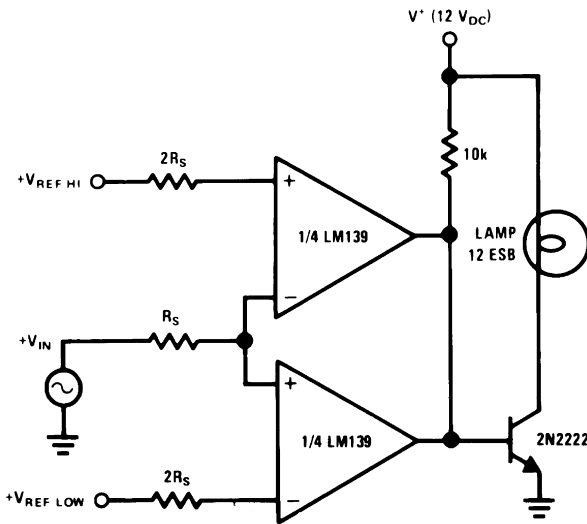

20113924

Output Strobing

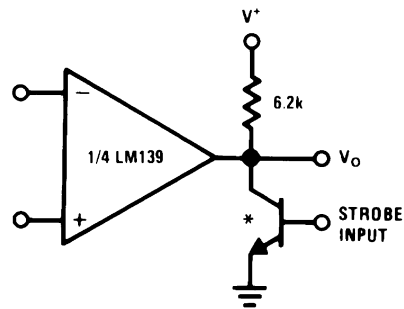

20113922

* Or open-collector logic gate without pull-up resistor

Comparing Input Voltages of Opposite Polarity

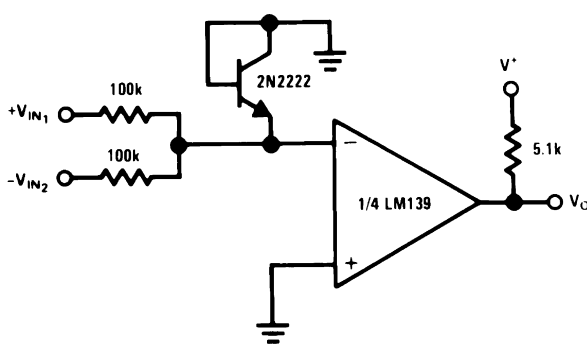

20113920

Crystal Controlled Oscillator

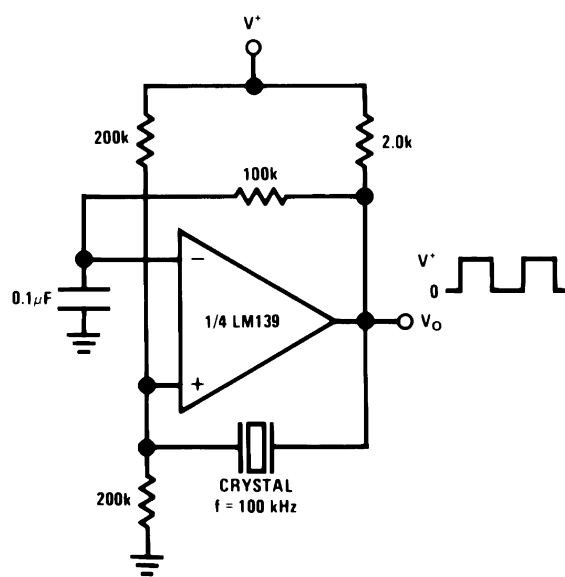

20113925

Typical Applications ($V^+ = 15 V_{DC}$) (Note 15) (Continued)

Two-Decade High-Frequency VCO

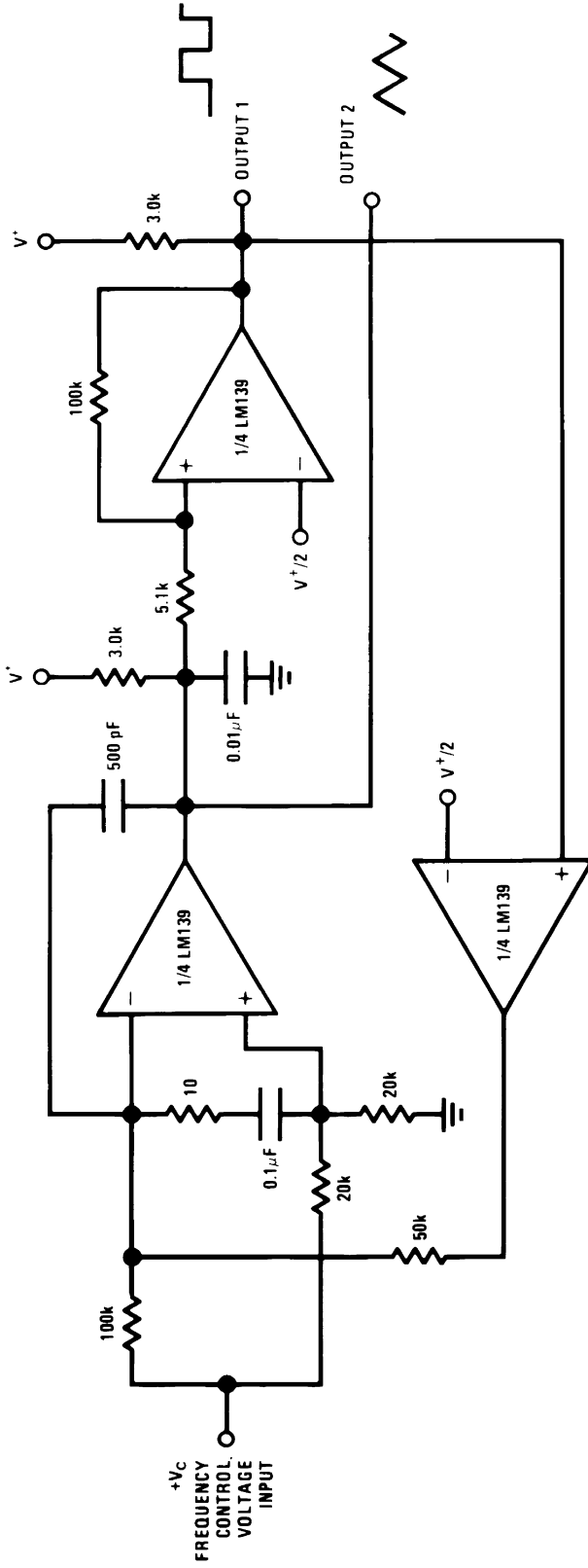

$V^+ = +50 V_{DC}$
 $250 mV_{DC} \leq V_C \leq +50 V_{DC}$
 $700 Hz \leq f_o \leq 100 kHz$

20113823

Typical Applications ($V^+ = 15\text{ V}_{DC}$) (Note 15) (Continued)

Transducer Amplifier

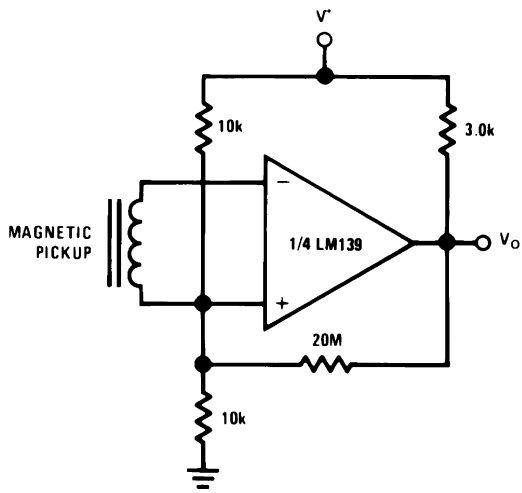

20113928

Zero Crossing Detector (Single Power Supply)

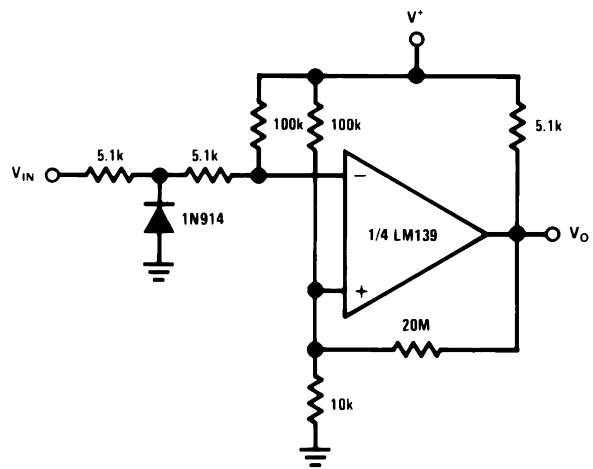

20113930

Split-Supply Applications ($V^+ = +15\text{ V}_{DC}$ and $V^- = -15\text{ V}_{DC}$)

MOS Clock Driver

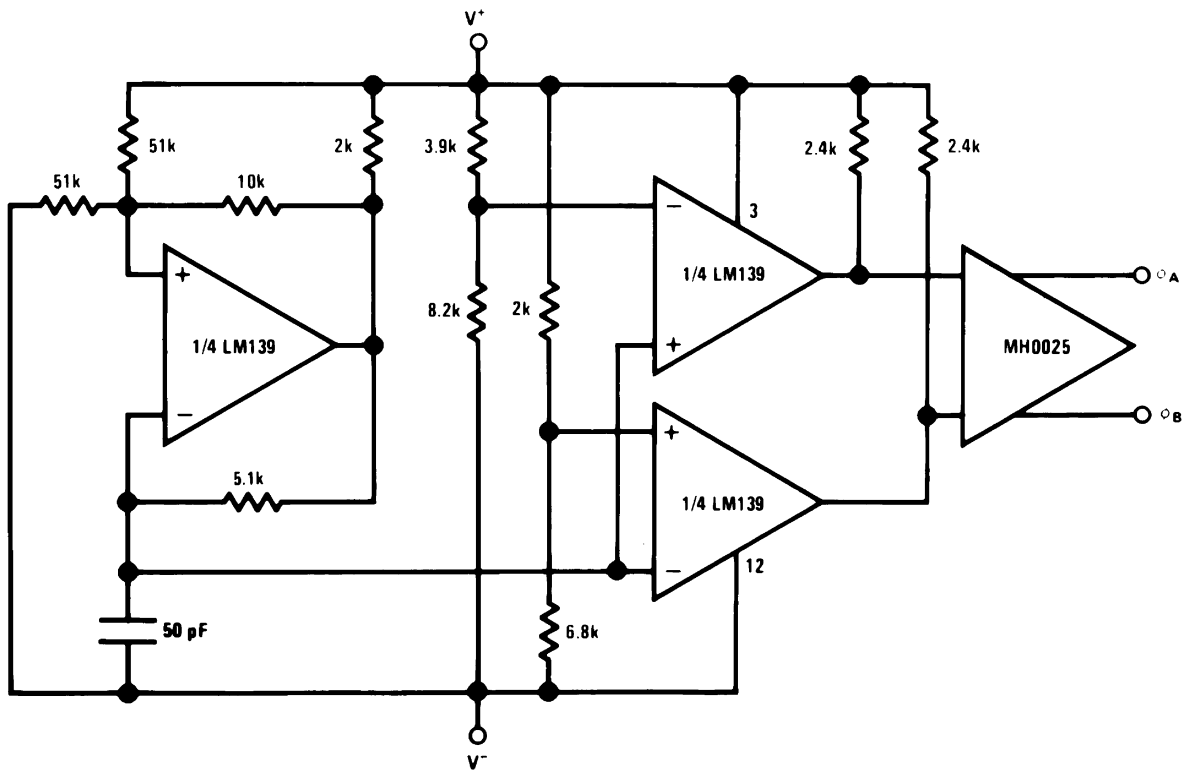

20113931

Split-Supply Applications ($V^+ = +15 V_{DC}$ and $V^- = -15 V_{DC}$) (Continued)

Zero Crossing Detector

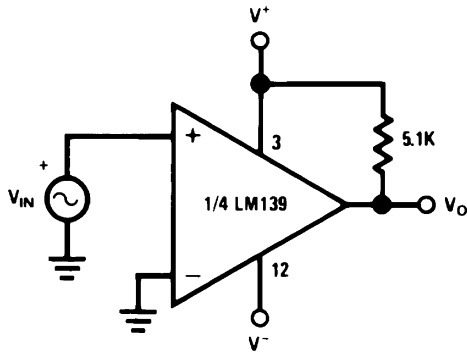

20113932

Comparator With a Negative Reference

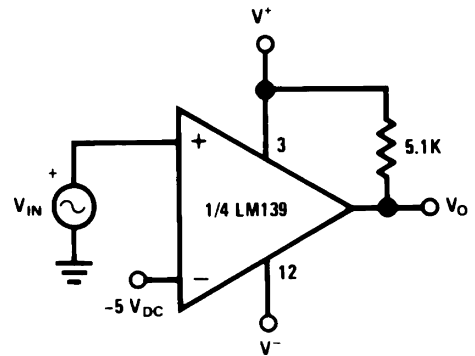

20113933

Schematic Diagram

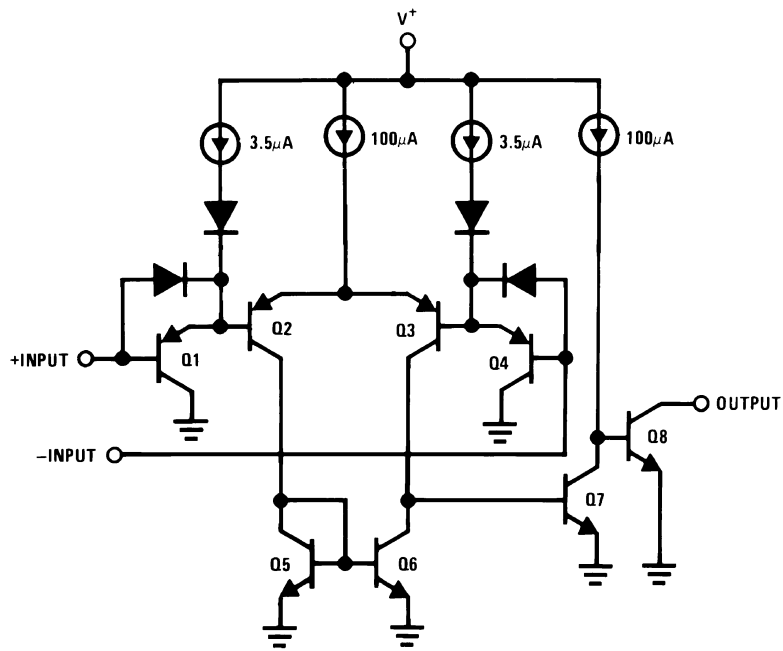

20113901

Connection Diagrams

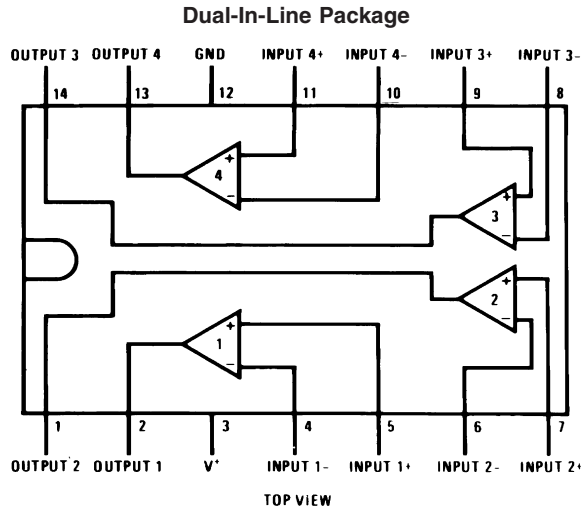

20113902

See NS Package Number M14A and N14A

Physical Dimensions inches (millimeters)

unless otherwise noted

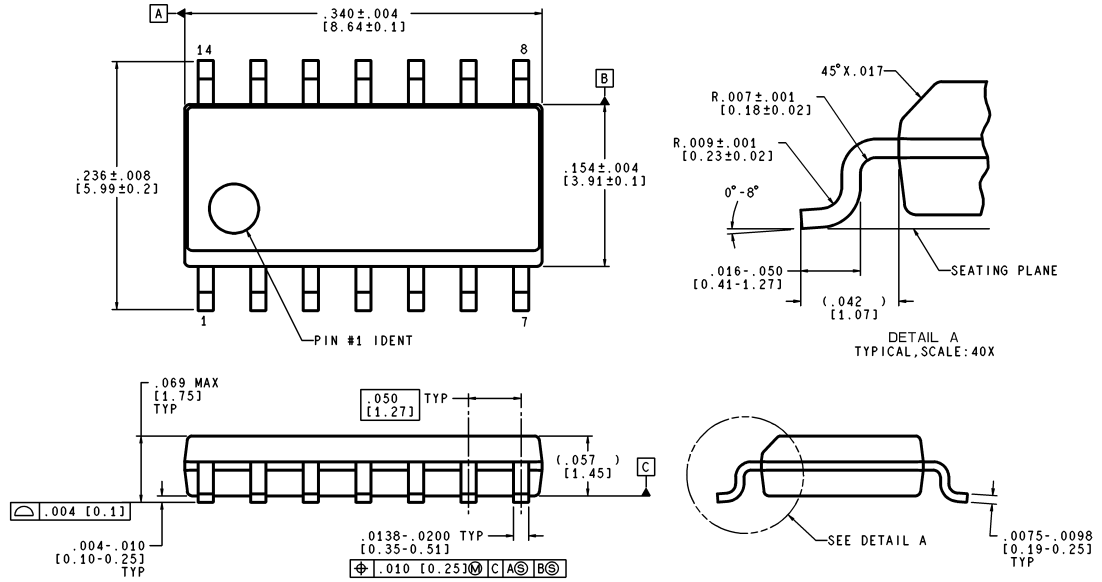

CONTROLLING DIMENSION IS INCH
VALUES IN [] ARE MILLIMETERS

M14A (Rev J)

S.O. Package (M) NS Package Number M14A

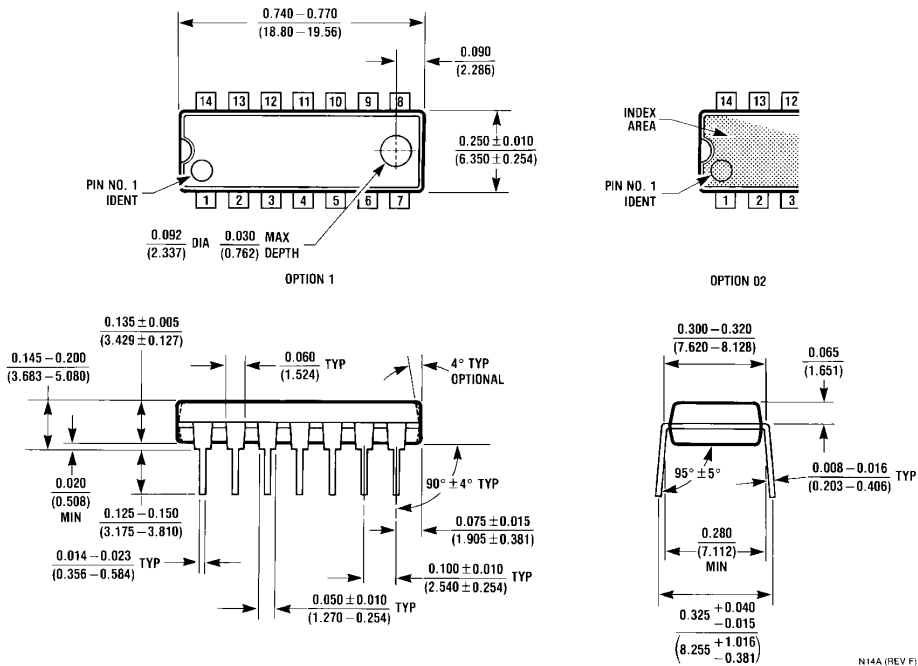

Molded Dual-In-Line Package (N) NS Package Number N14A

N14A (REV F)

Notes

National does not assume any responsibility for use of any circuitry described, no circuit patent licenses are implied and National reserves the right at any time without notice to change said circuitry and specifications.

For the most current product information visit us at www.national.com.

LIFE SUPPORT POLICY

NATIONAL'S PRODUCTS ARE NOT AUTHORIZED FOR USE AS CRITICAL COMPONENTS IN LIFE SUPPORT DEVICES OR SYSTEMS WITHOUT THE EXPRESS WRITTEN APPROVAL OF THE PRESIDENT AND GENERAL COUNSEL OF NATIONAL SEMICONDUCTOR CORPORATION. As used herein:

- | | |
|--|---|
| <p>1. Life support devices or systems are devices or systems which, (a) are intended for surgical implant into the body, or (b) support or sustain life, and whose failure to perform when properly used in accordance with instructions for use provided in the labeling, can be reasonably expected to result in a significant injury to the user.</p> | <p>2. A critical component is any component of a life support device or system whose failure to perform can be reasonably expected to cause the failure of the life support device or system, or to affect its safety or effectiveness.</p> |
|--|---|

BANNED SUBSTANCE COMPLIANCE

National Semiconductor certifies that the products and packing materials meet the provisions of the Customer Products Stewardship Specification (CSP-9-111C2) and the Banned Substances and Materials of Interest Specification (CSP-9-111S2) and contain no "Banned Substances" as defined in CSP-9-111S2.



National Semiconductor
Americas Customer
Support Center
 Email: new.feedback@nsc.com
 Tel: 1-800-272-9959

National Semiconductor
Europe Customer Support Center
 Fax: +49 (0) 180-530 85 86
 Email: europa.support@nsc.com
 Deutsch Tel: +49 (0) 69 9508 6208
 English Tel: +44 (0) 870 24 0 2171
 Français Tel: +33 (0) 1 41 91 8790

National Semiconductor
Asia Pacific Customer
Support Center
 Email: ap.support@nsc.com

National Semiconductor
Japan Customer Support Center
 Fax: 81-3-5639-7507
 Email: jpn.feedback@nsc.com
 Tel: 81-3-5639-7560