

LM2902EP

Low Power Quad Operational Amplifiers

General Description

The LM2902 consists of four independent, high gain, internally frequency compensated operational amplifiers which were designed specifically to operate from a single power supply over a wide range of voltages. Operation from split power supplies is also possible and the low power supply current drain is independent of the magnitude of the power supply voltage.

Application areas include transducer amplifiers, DC gain blocks and all the conventional op amp circuits which now can be more easily implemented in single power supply systems. For example, the LM2902 can be directly operated off of the standard +5V power supply voltage which is used in digital systems and will easily provide the required interface electronics without requiring the additional $\pm 15V$ power supplies.

ENHANCED PLASTIC

- Extended Temperature Performance of $-40^{\circ}C$ to $+85^{\circ}C$
- Baseline Control - Single Fab & Assembly Site
- Process Change Notification (PCN)
- Qualification & Reliability Data
- Solder (PbSn) Lead Finish is standard
- Enhanced Diminishing Manufacturing Sources (DMS) Support

Unique Characteristics

- In the linear mode the input common-mode voltage range includes ground and the output voltage can also swing to ground, even though operated from only a single power supply voltage
- The unity gain cross frequency is temperature compensated
- The input bias current is also temperature compensated

Advantages

- Eliminates need for dual supplies
- Four internally compensated op amps in a single package
- Allows directly sensing near GND and V_{OUT} also goes to GND
- Compatible with all forms of logic
- Power drain suitable for battery operation

Features

- Internally frequency compensated for unity gain
- Large DC voltage gain 100 dB
- Wide bandwidth (unity gain) 1 MHz (temperature compensated)
- Wide power supply range:
Single supply 3V to 26V
or dual supplies $\pm 1.5V$ to $\pm 13V$
- Very low supply current drain (700 μA)—essentially independent of supply voltage
- Low input biasing current 45 nA (temperature compensated)
- Low input offset voltage 2 mV and offset current: 5 nA
- Input common-mode voltage range includes ground
- Differential input voltage range equal to the power supply voltage
- Large output voltage swing 0V to $V^+ - 1.5V$

Applications

- Selected Military Applications
- Selected Avionics Applications

Ordering Information

PART NUMBER	VID PART NUMBER	NS PACKAGE NUMBER (Note 3)
LM2902MEP	V62/04744-01	M14A
(Notes 1, 2)	TBD	TBD

Note 1: For the following (Enhanced Plastic) version, check for availability: LM2902MXEP, LM2902MTEP, LM2902MTXEP, LM2902NEP. Parts listed with an "X" are provided in Tape & Reel and parts without an "X" are in Rails.

Note 2: FOR ADDITIONAL ORDERING AND PRODUCT INFORMATION, PLEASE VISIT THE ENHANCED PLASTIC WEB SITE AT: www.national.com/mil

Note 3: Refer to package details under Physical Dimensions

Connection Diagram

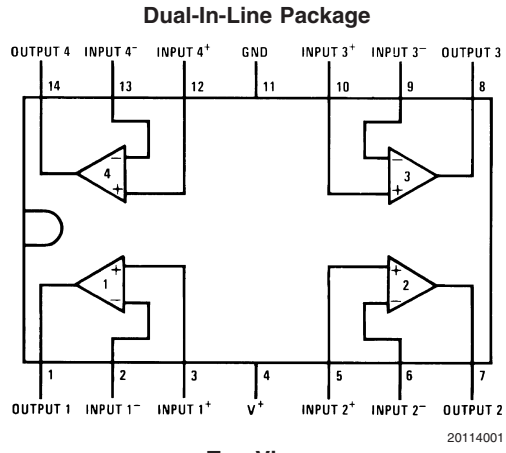

Schematic Diagram (Each Amplifier)

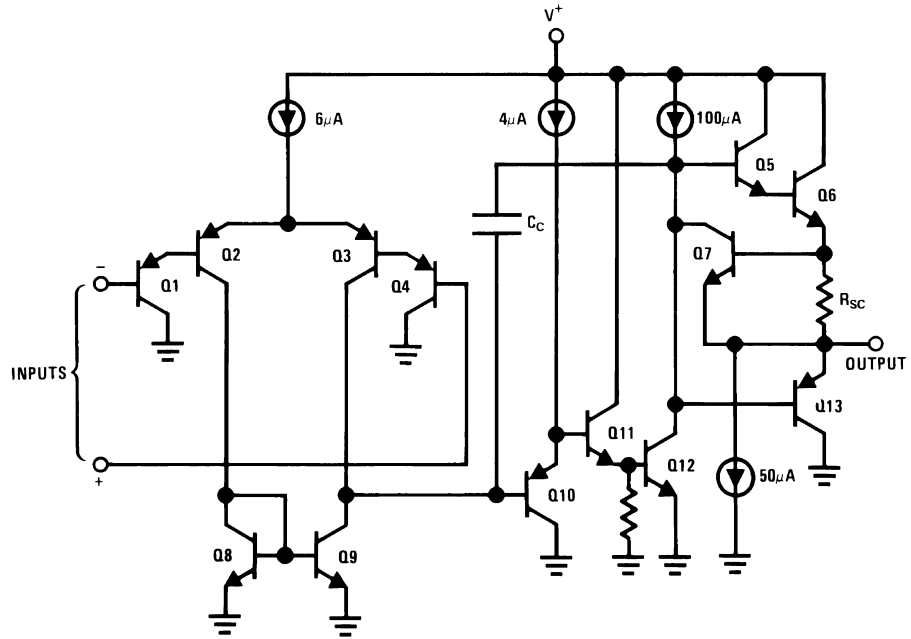

Absolute Maximum Ratings (Note 13)

If Military/Aerospace specified devices are required, please contact the National Semiconductor Sales Office/Distributors for availability and specifications.

Supply Voltage, V^+	26V
Differential Input Voltage	26V
Input Voltage	-0.3V to +26V
Input Current ($V_{IN} < -0.3V$) (Note 6)	50 mA
Power Dissipation (Note 4)	
Molded DIP	1130 mW
Small Outline Package	800 mW
Output Short-Circuit to GND (One Amplifier) (Note 5) $V^+ \leq 15V$ and $T_A = 25^\circ C$	Continuous
Operating Temperature Range	-40°C to +85°C
Storage Temperature Range	-65°C to +150°C
Lead Temperature (Soldering, 10 seconds)	220°C
Soldering Information	
Small Outline Package	
Vapor Phase (60 seconds)	215°C
Infrared (15 seconds)	220°C
ESD Tolerance (Note 14)	250V

Electrical Characteristics

$V^+ = +5.0V$, unless otherwise stated (Notes 7, 8)

Parameter	Conditions	LM2902			Units
		Min	Typ	Max	
Input Offset Voltage (Note 9)	$T_A = 25^\circ C$		2	7	mV
Input Bias Current (Note 10)	$I_{IN(+)} \text{ or } I_{IN(-)}, V_{CM} = 0V, T_A = 25^\circ C$		45	250	nA
Input Offset Current	$I_{IN(+)} \text{ or } I_{IN(-)}, V_{CM} = 0V, T_A = 25^\circ C$		5	50	nA
Input Common-Mode Voltage Range (Note 11)	$V^+ V^+ = 26V, T_A = 25^\circ C$	0		$V^+ - 1.5$	V
Supply Current	Over Full Temperature Range $R_L = \infty$ On All Op Amps $V^+ = 26V$ $V^+ = 5V$		1.5 0.7	3 1.2	mA
Large Signal Voltage Gain	$V^+ = 15V, R_L \geq 2k\Omega,$ ($V_O = 1V$ to $11V$), $T_A = 25^\circ C$	25	100		V/mV
Common-Mode Rejection Ratio	DC, $V_{CM} = 0V$ to $V^+ - 1.5V,$ $T_A = 25^\circ C$	50	70		dB
Power Supply Rejection Ratio	$V^+ = 5V$ to $26V$ $T_A = 25^\circ C$	50	100		dB
Amplifier-to-Amplifier Coupling (Note 12)	$f = 1 \text{ kHz to } 20 \text{ kHz}, T_A = 25^\circ C$ (Input Referred)		-120		dB
Output Current	Source $V_{IN^+} = 1V, V_{IN^-} = 0V,$ $V^+ = 15V, V_O = 2V, T_A = 25^\circ C$	20	40		mA
	Sink $V_{IN^-} = 1V, V_{IN^+} = 0V,$ $V^+ = 15V, V_O = 2V, T_A = 25^\circ C$	10	20		
	Sink $V_{IN^-} = 1V, V_{IN^+} = 0V,$ $V^+ = 15V, V_O = 200 \text{ mV}, T_A = 25^\circ C$	12	50		μA

Electrical Characteristics (Continued)V⁺ = +5.0V, unless otherwise stated (Notes 7, 8)

Parameter		Conditions		LM2902			Units
				Min	Typ	Max	
Short Circuit to Ground		(Note 5) V ⁺ = 15V, T _A = 25°C			40	60	mA
Input Offset Voltage		(Note 9)				10	mV
V _{OS} Drift		R _S = 0Ω			7		μV/°C
Input Offset Current		I _{IN(+)} - I _{IN(-)} , V _{CM} = 0V			45	200	nA
I _{OS} Drift		R _S = 0Ω			10		pA/°C
Input Bias Current		I _{IN(+)} or I _{IN(-)}			40	500	nA
Input Common-Mode Voltage Range (Note 11)		V ⁺ = 26V		0		V ⁺ -2	V
Large Signal Voltage Gain		V ⁺ = +15V (V _O Swing = 1V to 11V) R _L ≥ 2 kΩ		15			V/mV
Output Voltage Swing	V _{OH}	V ⁺ = 26V	R _L = 10 kΩ	23	24		V
	V _{OL}	V ⁺ = 5V, R _L = 10 kΩ			5	100	mV
Output Current	Source	V _O = 2V	V _{IN} ⁺ = +1V, V _{IN} ⁻ = 0V, V ⁺ = 15V	10	20		mA
	Sink		V _{IN} ⁻ = +1V, V _{IN} ⁺ = 0V, V ⁺ = 15V	5	8		

Note 4: For operating at high temperatures, the LM2902EP must be derated based on a +125°C maximum junction temperature and a thermal resistance of 88°C/W which applies for the device soldered in a printed circuit board, operating in a still air ambient. The dissipation is the total of all four amplifiers — use external resistors, where possible, to allow the amplifier to saturate or to reduce the power which is dissipated in the integrated circuit.

Note 5: Short circuits from the output to V⁺ can cause excessive heating and eventual destruction. When considering short circuits to ground, the maximum output current is approximately 40 mA independent of the magnitude of V⁺. At values of supply voltage in excess of +15V, continuous short-circuits can exceed the power dissipation ratings and cause eventual destruction. Destructive dissipation can result from simultaneous shorts on all amplifiers.

Note 6: This input current will only exist when the voltage at any of the input leads is driven negative. It is due to the collector-base junction of the input PNP transistors becoming forward biased and thereby acting as input diode clamps. In addition to this diode action, there is also lateral NPN parasitic transistor action on the IC chip. This transistor action can cause the output voltages of the op amps to go to the V⁺ voltage level (or to ground for a large overdrive) for the time duration that an input is driven negative. This is not destructive and normal output states will re-establish when the input voltage, which was negative, again returns to a value greater than -0.3V (at 25°C).

Note 7: The LM2902EP specifications are limited to -40°C ≤ T_A ≤ +85°C.

Note 8: "Testing and other quality control techniques are used to the extent deemed necessary to ensure product performance over the specified temperature range. Product may not necessarily be tested across the full temperature range and all parameters may not necessarily be tested. In the absence of specific PARAMETRIC testing, product performance is assured by characterization and/or design."

Note 9: V_O = 1.4V, R_S = 0Ω with V⁺ from 5V to 26V; and over the full input common-mode range (0V to V⁺ - 1.5V)

Note 10: The direction of the input current is out of the IC due to the PNP input stage. This current is essentially constant, independent of the state of the output so no loading change exists on the input lines.

Note 11: The input common-mode voltage of either input signal voltage should not be allowed to go negative by more than 0.3V (at 25°C). The upper end of the common-mode voltage range is V⁺ - 1.5V (at 25°C), but either or both inputs can go to +26V without damage, independent of the magnitude of V⁺.

Note 12: Due to proximity of external components, insure that coupling is not originating via stray capacitance between these external parts. This typically can be detected as this type of capacitance increases at higher frequencies.

Note 13: Absolute Maximum Ratings indicate limits beyond which damage to the device may occur.

Note 14: Human body model, 1.5 kΩ in series with 100 pF.

Note 15: The LM124 within this data sheet's graphics is referenced because of it's a similarity to the LM2902, however is not offered in this data sheet.

Typical Performance Characteristics

Input Voltage Range

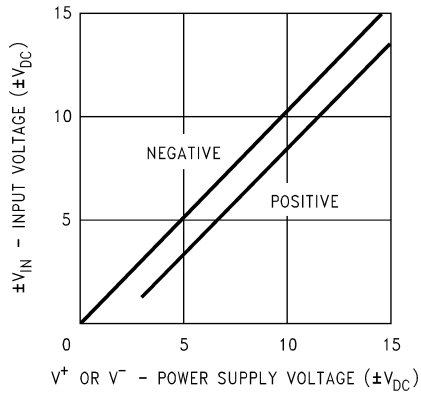

20114034

Input Current

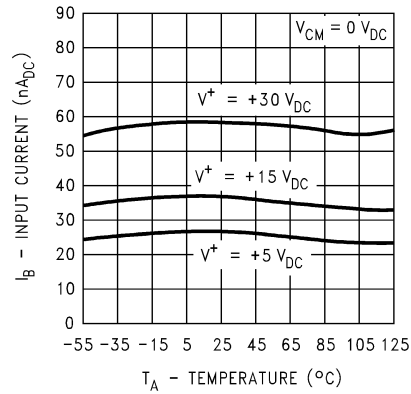

20114035

Supply Current

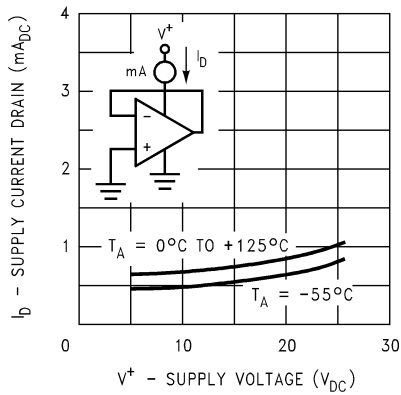

20114036

Voltage Gain

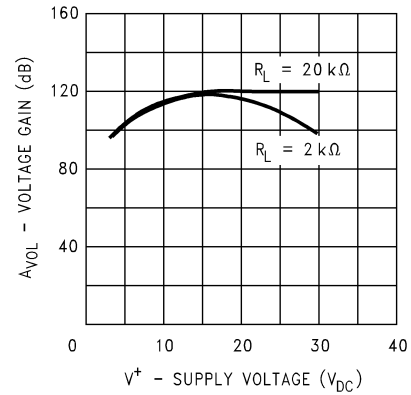

20114037

Open Loop Frequency Response

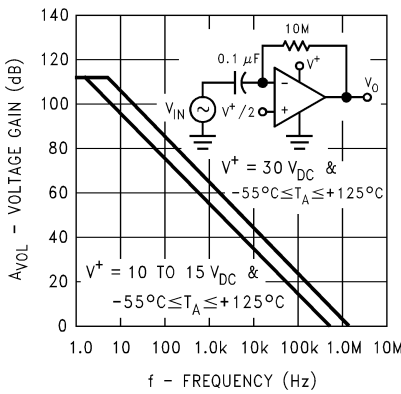

20114038

Common Mode Rejection Ratio

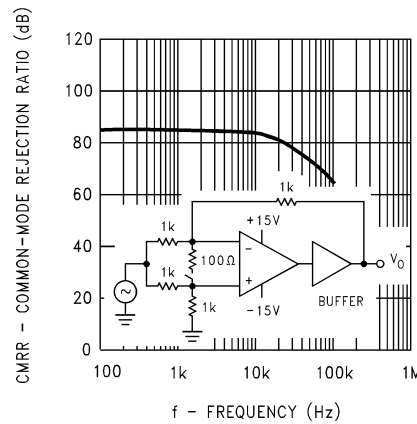

20114039

Typical Performance Characteristics (Continued)

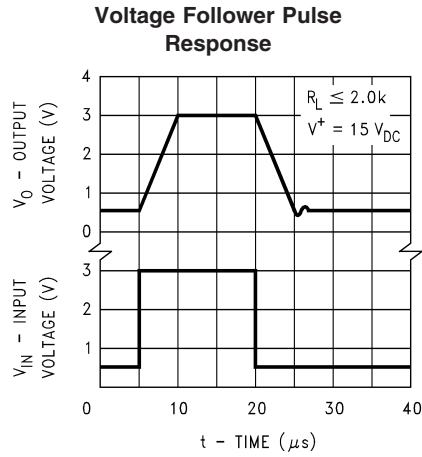

20114040

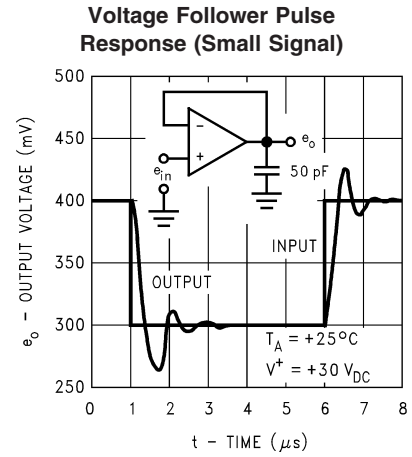

20114041

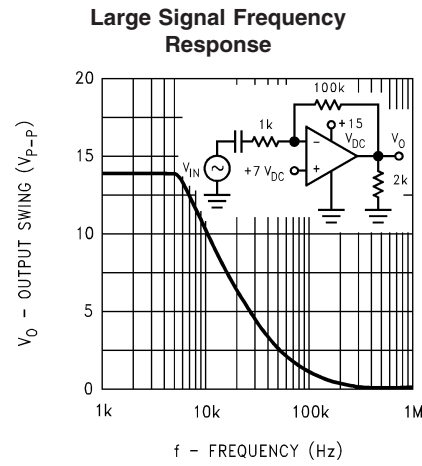

20114042

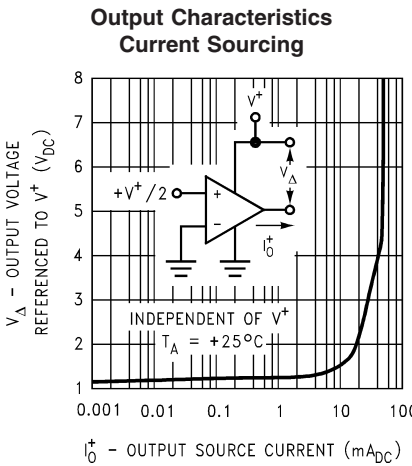

20114043

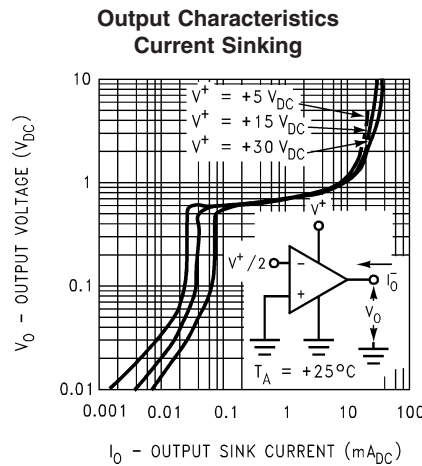

20114044

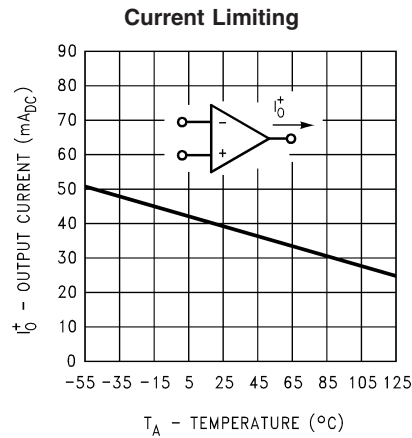

20114045

Typical Performance Characteristics (Continued)

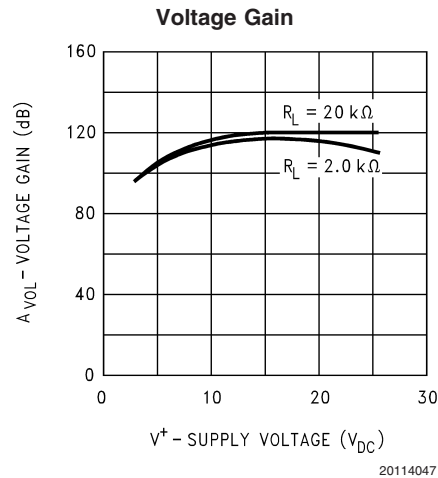
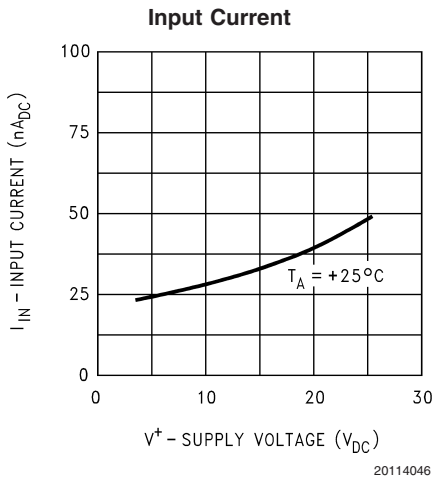

Application Hints

The LM2902EP is an op amp which operates with only a single power supply voltage, has true-differential inputs, and remains in the linear mode with an input common-mode voltage of 0 V_{DC}. This amplifier operates over a wide range of power supply voltages with little change in performance characteristics. At 25°C amplifier operation is possible down to a minimum supply voltage of 2.3 V_{DC}.

The pinouts of the package have been designed to simplify PC board layouts. Inverting inputs are adjacent to outputs for all of the amplifiers and the outputs have also been placed at the corners of the package (pins 1, 7, 8, and 14).

Precautions should be taken to insure that the power supply for the integrated circuit never becomes reversed in polarity or that the unit is not inadvertently installed backwards in a test socket as an unlimited current surge through the resulting forward diode within the IC could cause fusing of the internal conductors and result in a destroyed unit.

Large differential input voltages can be easily accommodated and, as input differential voltage protection diodes are not needed, no large input currents result from large differential input voltages. The differential input voltage may be larger than V⁺ without damaging the device. Protection should be provided to prevent the input voltages from going negative more than -0.3 V_{DC} (at 25°C). An input clamp diode with a resistor to the IC input terminal can be used.

To reduce the power supply drain, the amplifier has a class A output stage for small signal levels which converts to class B in a large signal mode. This allows the amplifier to both source and sink large output currents. Therefore both NPN and PNP external current boost transistors can be used to extend the power capability of the basic amplifier. The output voltage needs to raise approximately 1 diode drop above ground to bias the on-chip vertical PNP transistor for output current sinking applications.

For ac applications, where the load is capacitively coupled to the output of the amplifier, a resistor should be used, from the output of the amplifier to ground to increase the class A bias current and prevent crossover distortion.

Where the load is directly coupled, as in dc applications, there is no crossover distortion.

Capacitive loads which are applied directly to the output of the amplifier reduce the loop stability margin. Values of 50 pF can be accommodated using the worst-case non-inverting unity gain connection. Large closed loop gains or resistive isolation should be used if larger load capacitance must be driven by the amplifier.

The bias network of the LM2902EP establishes a drain current which is independent of the magnitude of the power supply voltage over the range of from 3 V_{DC} to 26 V_{DC}.

Output short circuits either to ground or to the positive power supply should be of short time duration. Units can be destroyed, not as a result of the short circuit current causing metal fusing, but rather due to the large increase in IC chip dissipation which will cause eventual failure due to excessive junction temperatures. Putting direct short-circuits on more than one amplifier at a time will increase the total IC power dissipation to destructive levels, if not properly protected with external dissipation limiting resistors in series with the output leads of the amplifiers. The larger value of output source current which is available at 25°C provides a larger output current capability at elevated temperatures (see typical performance characteristics) than a standard IC op amp.

The circuits presented in the section on typical applications emphasize operation on only a single power supply voltage. If complementary power supplies are available, all of the standard op amp circuits can be used. In general, introducing a pseudo-ground (a bias voltage reference of V⁺/2) will allow operation above and below this value in single power supply systems. Many application circuits are shown which take advantage of the wide input common-mode voltage range which includes ground. In most cases, input biasing is not required and input voltages which range to ground can easily be accommodated.

Typical Single-Supply Applications $(V^+ = 5.0 V_{DC})$ (Note 15)

Non-Inverting DC Gain ($0V$ Input = $0V$ Output)

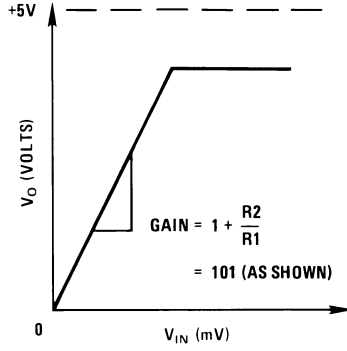
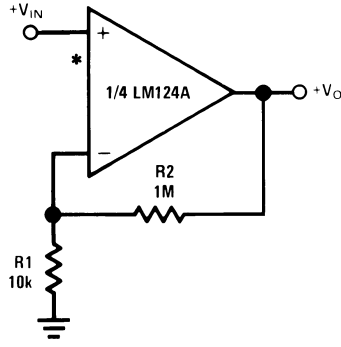

20114005

*R not needed due to temperature independent I_{IN}

DC Summing Amplifier $(V_{IN's} \geq 0 V_{DC}$ and $V_O \geq V_{DC})$

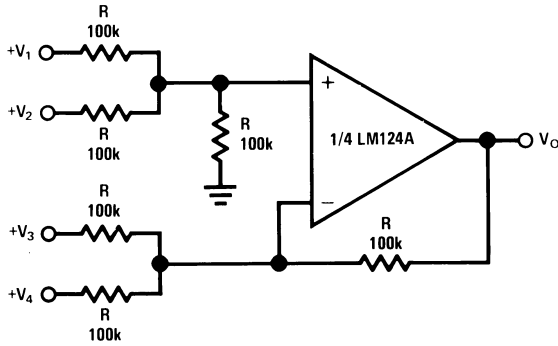

20114006

Where: $V_O = V_1 + V_2 - V_3 - V_4$
 $(V_1 + V_2) \geq (V_3 + V_4)$ to keep $V_O > 0 V_{DC}$

Power Amplifier

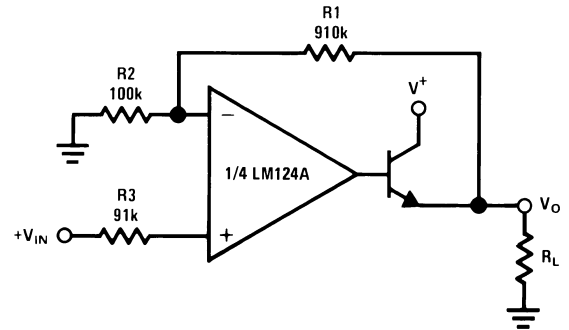

20114007

$V_O = 0 V_{DC}$ for $V_{IN} = 0 V_{DC}$
 $A_V = 10$

Typical Single-Supply Applications ($V^+ = 5.0 V_{DC}$) (Note 15) (Continued)

LED Driver

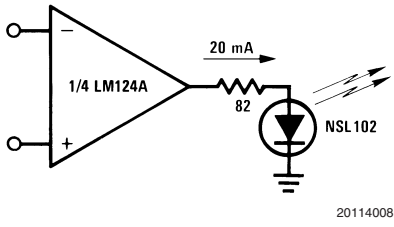

“BI-QUAD” RC Active Bandpass Filter

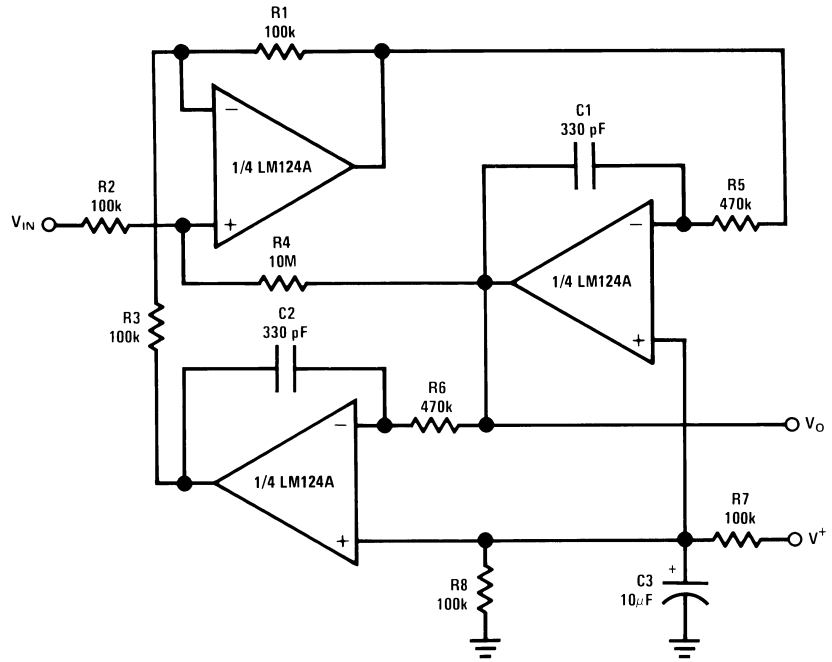

$f_o = 1 \text{ kHz}$
 $Q = 50$
 $A_V = 100 \text{ (40 dB)}$

Fixed Current Sources

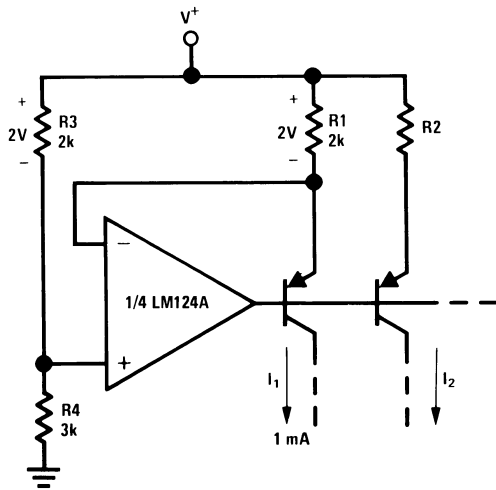

$$I_2 = \left(\frac{R_1}{R_2} \right) I_1$$

Lamp Driver

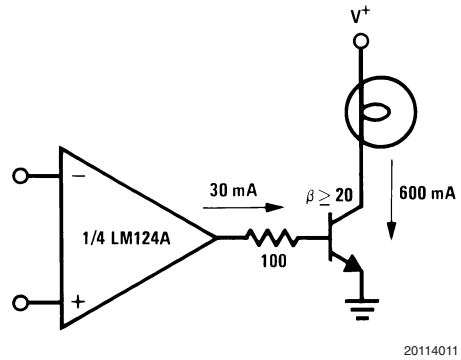

Typical Single-Supply Applications

($V^+ = 5.0 V_{DC}$) (Note 15) (Continued)

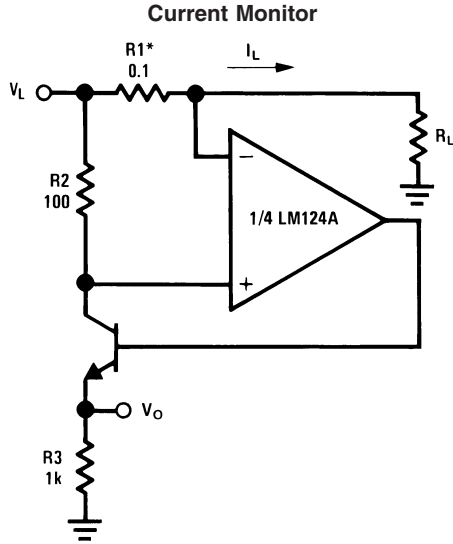

20114012

$$V_O = \frac{1V(I_L)}{1A}$$

$$V_L \leq V^+ - 2V$$

*(Increase $R1$ for I_L small)

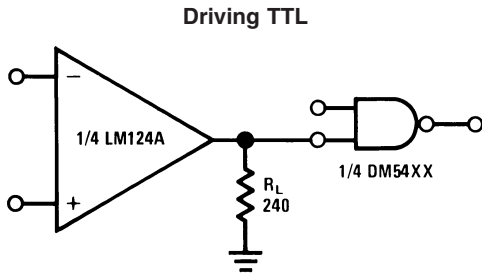

20114013

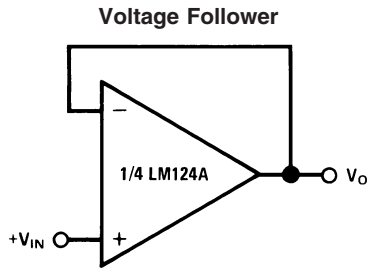

20114014

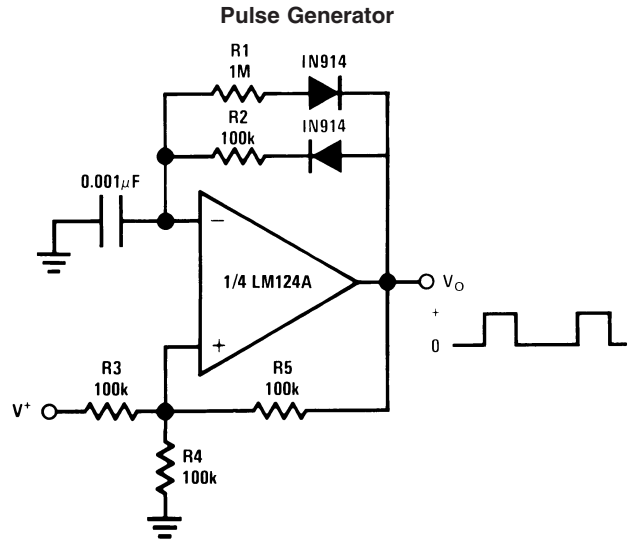

20114015

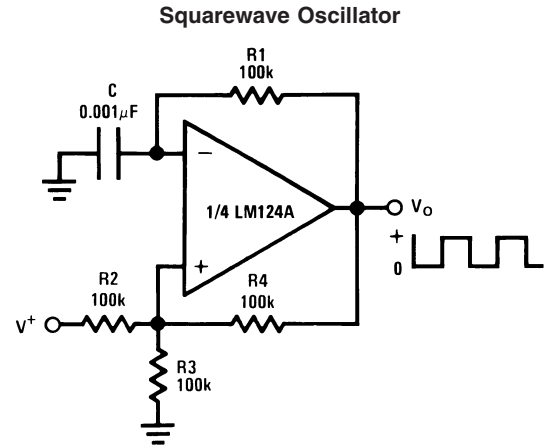

20114016

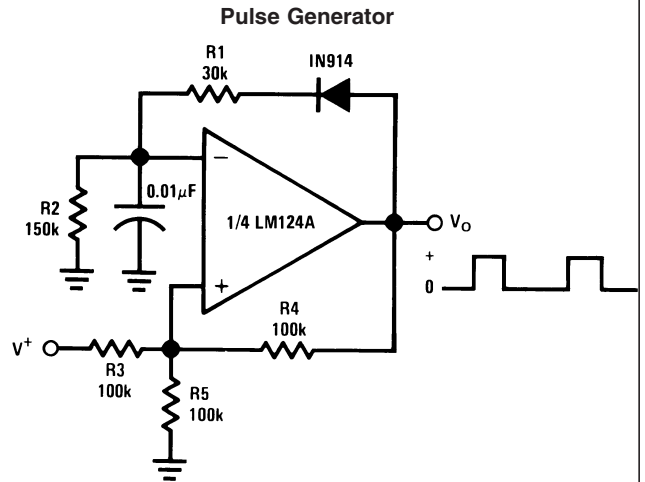

20114017

Typical Single-Supply Applications ($V^+ = 5.0 V_{DC}$) (Note 15) (Continued)

High Compliance Current Sink

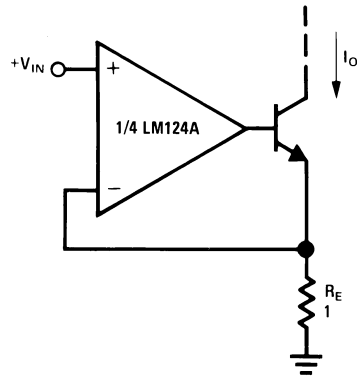

20114018

$I_o = 1 \text{ amp/volt } V_{IN}$
(Increase R_E for I_o small)

Low Drift Peak Detector

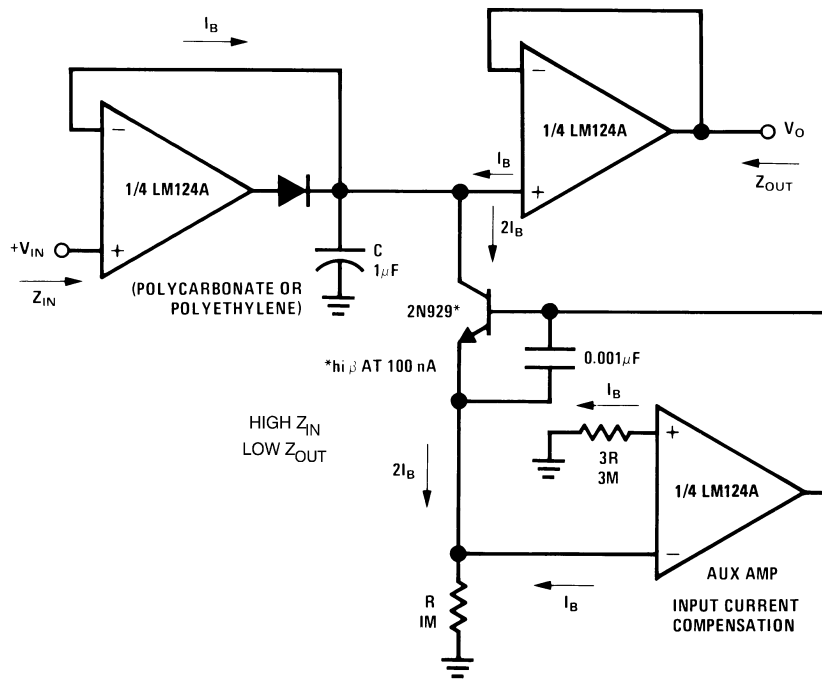

20114019

Typical Single-Supply Applications ($V^+ = 5.0 V_{DC}$) (Note 15) (Continued)

Comparator with Hysteresis

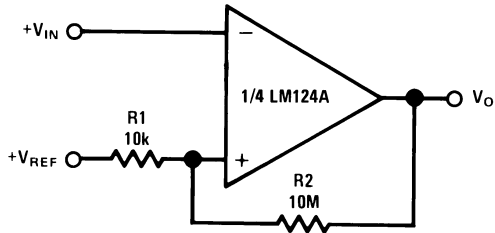

20114020

Ground Referencing a Differential Input Signal

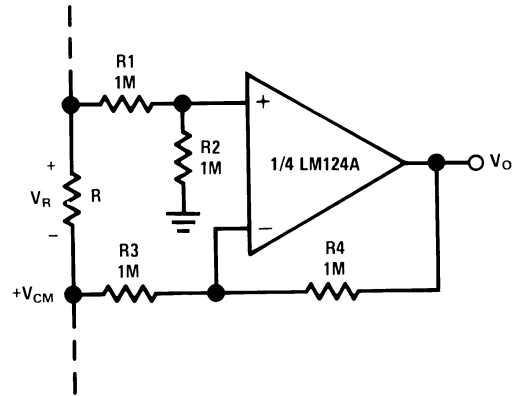

$V_O = V_R$

20114021

Voltage Controlled Oscillator Circuit

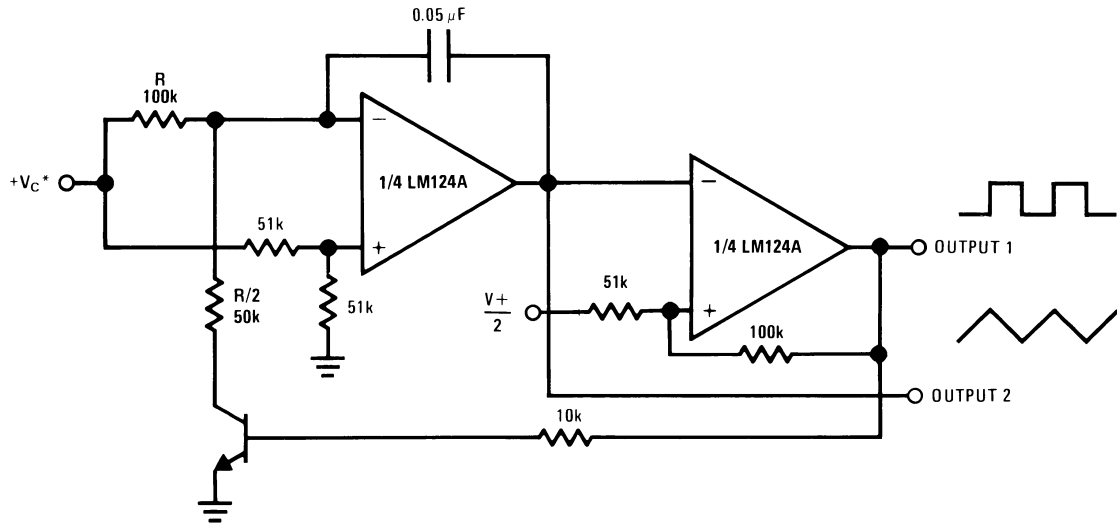

20114022

*Wide control voltage range: $0 V_{DC} \leq V_C \leq 2 (V^+ - 1.5 V_{DC})$

Photo Voltaic-Cell Amplifier

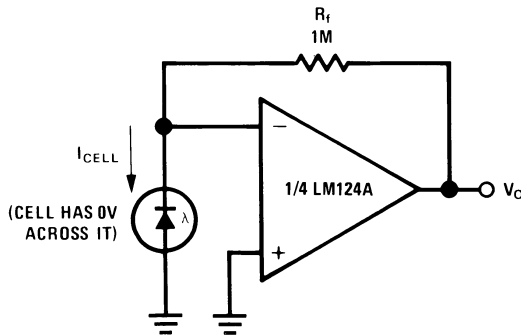

20114023

Typical Single-Supply Applications ($V^+ = 5.0 V_{DC}$) (Note 15) (Continued)

AC Coupled Inverting Amplifier

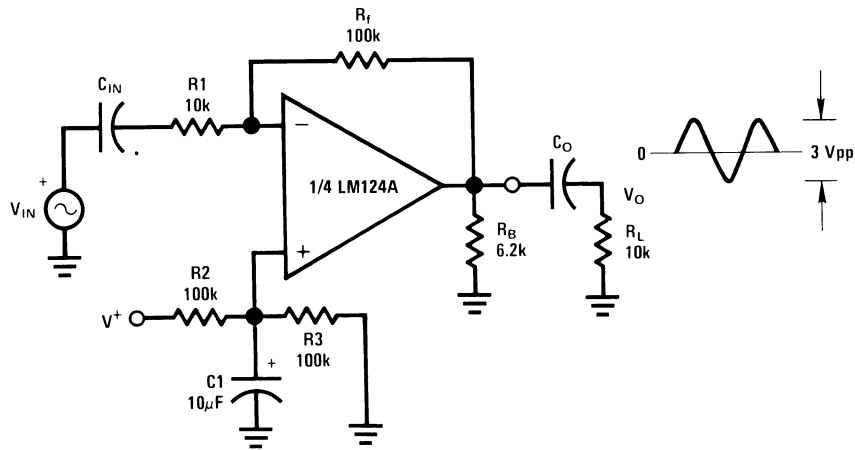

20114024

$$A_V = \frac{R_f}{R_1} \text{ (As shown, } A_V = 10\text{)}$$

AC Coupled Non-Inverting Amplifier

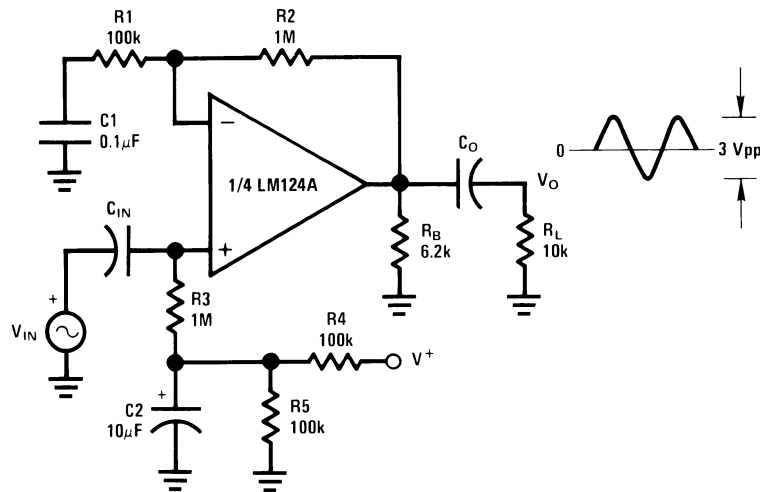

20114025

$$A_V = 1 + \frac{R_2}{R_1}$$

$$A_V = 11 \text{ (As shown)}$$

Typical Single-Supply Applications ($V^+ = 5.0 V_{DC}$) (Note 15) (Continued)

DC Coupled Low-Pass RC Active Filter

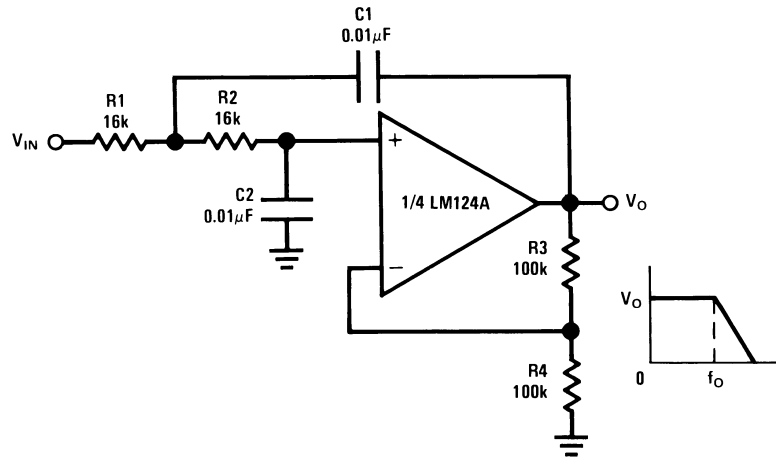

20114026

$f_0 = 1 \text{ kHz}$
 $Q = 1$
 $A_V = 2$

High Input Z, DC Differential Amplifier

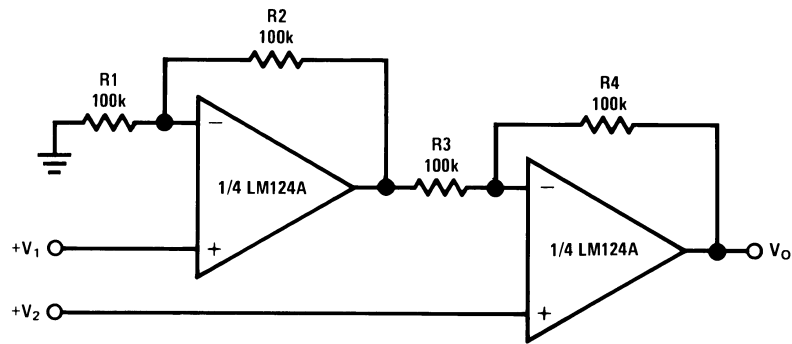

20114027

For $\frac{R1}{R2} = \frac{R4}{R3}$ (CMRR depends on this resistor ratio match)

$V_O = 1 + \frac{R4}{R3} (V_2 - V_1)$

As shown: $V_O = 2(V_2 - V_1)$

Typical Single-Supply Applications ($V^+ = 5.0 V_{DC}$) (Note 15) (Continued)

High Input Z Adjustable-Gain DC Instrumentation Amplifier

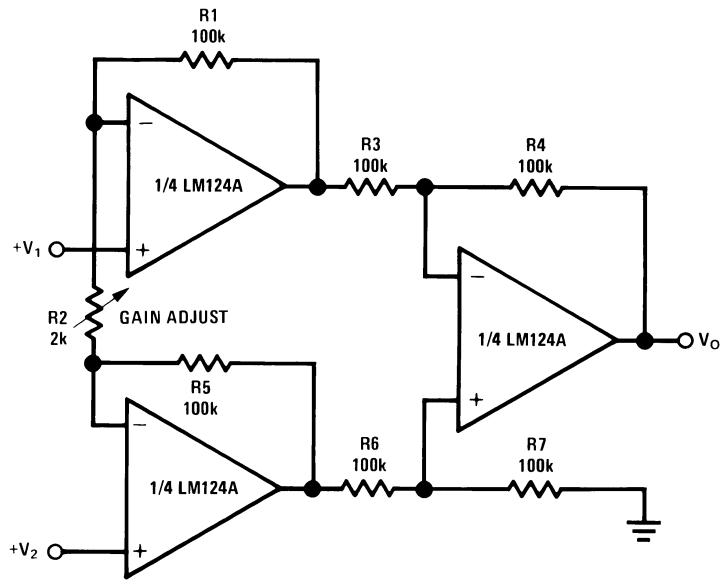

20114028

If $R1 = R5$ & $R3 = R4 = R6 = R7$ (CMRR depends on match)

$$V_O = 1 + \frac{2R1}{R2} (V_2 - V_1)$$

As shown $V_O = 101 (V_2 - V_1)$

Using Symmetrical Amplifiers to Reduce Input Current (General Concept)

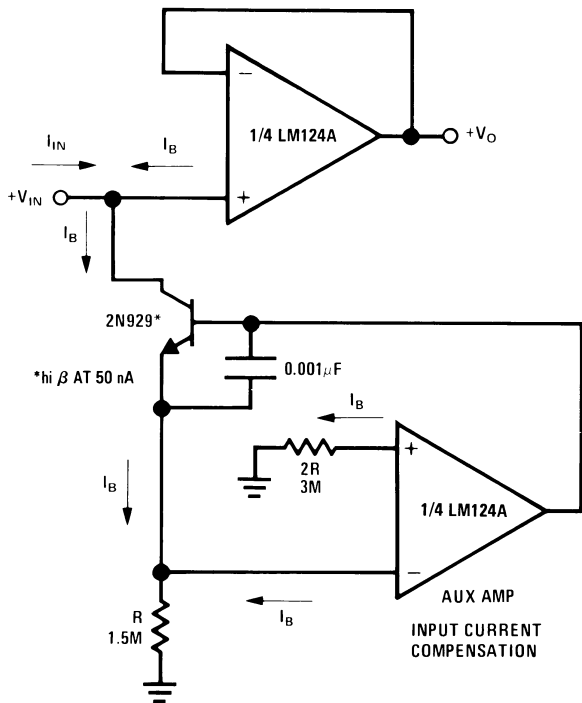

20114029

Bridge Current Amplifier

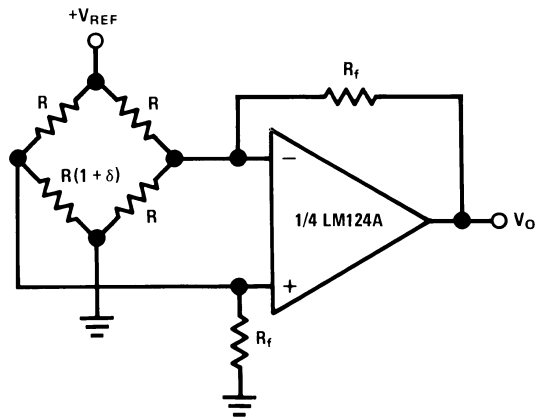

20114030

For $\delta \ll 1$ and $R_f \gg R$

$$V_O \approx V_{REF} \left(\frac{\delta}{2} \right) \frac{R_f}{R}$$

Typical Single-Supply Applications ($V^+ = 5.0 V_{DC}$) (Note 15) (Continued)

Bandpass Active Filter

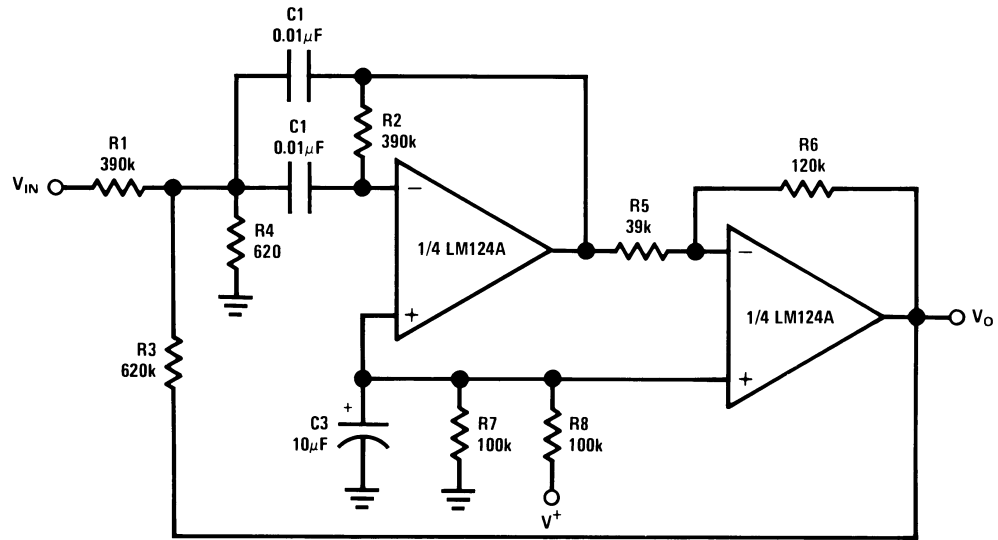

20114031

 $f_0 = 1 \text{ kHz}$ $Q = 25$

Physical Dimensions inches (millimeters) unless otherwise noted

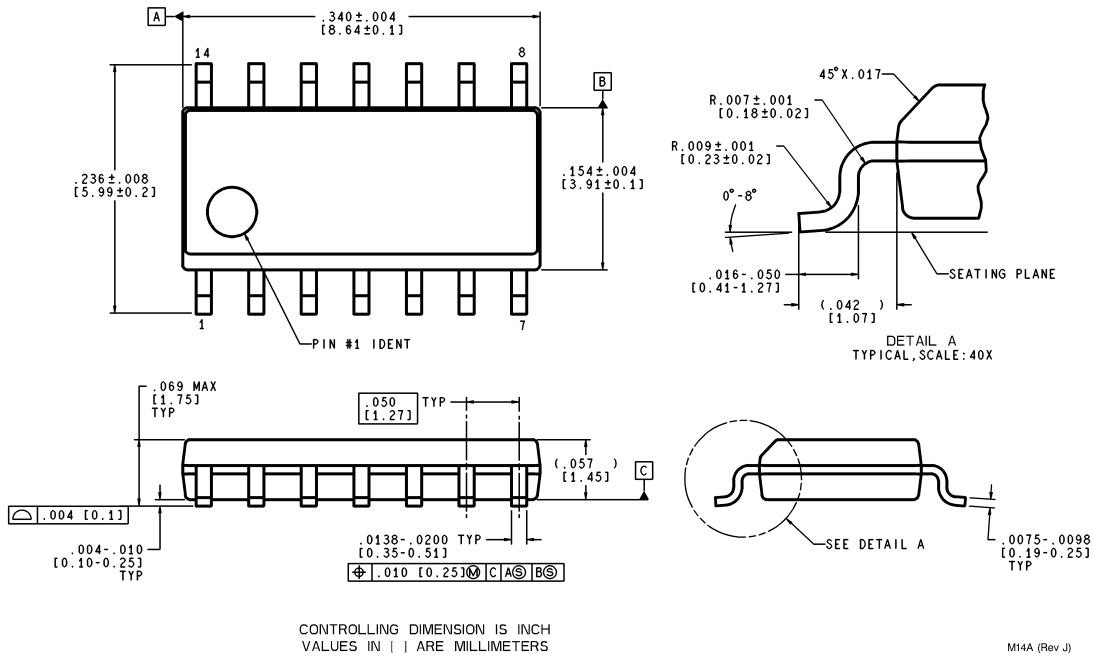

**MX S.O. Package (M)
NS Package Number M14A**

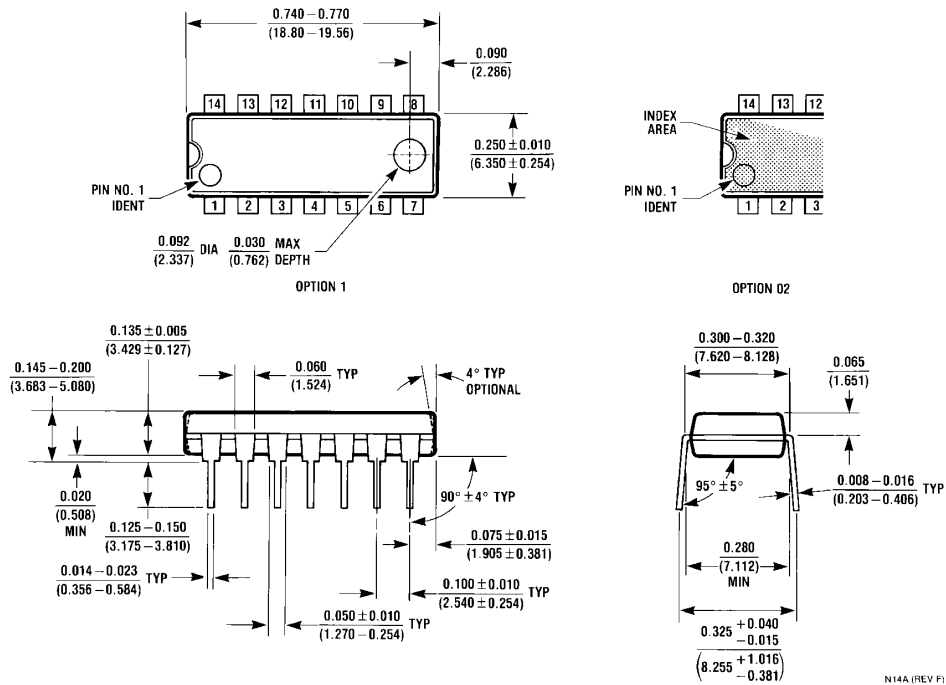

Notes

National does not assume any responsibility for use of any circuitry described, no circuit patent licenses are implied and National reserves the right at any time without notice to change said circuitry and specifications.

For the most current product information visit us at www.national.com.

LIFE SUPPORT POLICY

NATIONAL'S PRODUCTS ARE NOT AUTHORIZED FOR USE AS CRITICAL COMPONENTS IN LIFE SUPPORT DEVICES OR SYSTEMS WITHOUT THE EXPRESS WRITTEN APPROVAL OF THE PRESIDENT AND GENERAL COUNSEL OF NATIONAL SEMICONDUCTOR CORPORATION. As used herein:

1. Life support devices or systems are devices or systems which, (a) are intended for surgical implant into the body, or (b) support or sustain life, and whose failure to perform when properly used in accordance with instructions for use provided in the labeling, can be reasonably expected to result in a significant injury to the user.
2. A critical component is any component of a life support device or system whose failure to perform can be reasonably expected to cause the failure of the life support device or system, or to affect its safety or effectiveness.

BANNED SUBSTANCE COMPLIANCE

National Semiconductor manufactures products and uses packing materials that meet the provisions of the Customer Products Stewardship Specification (CSP-9-111C2) and the Banned Substances and Materials of Interest Specification (CSP-9-111S2) and contain no "Banned Substances" as defined in CSP-9-111S2.



National Semiconductor
Americas Customer
Support Center
Email: new.feedback@nsc.com
Tel: 1-800-272-9959

www.national.com

National Semiconductor
Europe Customer Support Center
Fax: +49 (0) 180-530 85 86
Email: europe.support@nsc.com
Deutsch Tel: +49 (0) 69 9508 6208
English Tel: +44 (0) 870 24 0 2171
Français Tel: +33 (0) 1 41 91 8790

National Semiconductor
Asia Pacific Customer
Support Center
Email: ap.support@nsc.com

National Semiconductor
Japan Customer Support Center
Fax: 81-3-5639-7507
Email: jpn.feedback@nsc.com
Tel: 81-3-5639-7560