

LM2936-5.0EP

Enhanced Plastic Ultra-Low Quiescent Current 5V Regulator

General Description

The LM2936EP ultra-low quiescent current regulator features low dropout voltage and low current in the standby mode. With less than 15 μA quiescent current at a 100 μA load, the LM2936EP is ideally suited for automotive and other battery operated systems. The LM2936EP retains all of the features that are common to low dropout regulators including a low dropout PNP pass device, short circuit protection, reverse battery protection, and thermal shutdown. The LM2936EP has a 40V maximum operating voltage limit, a -40°C to $+125^{\circ}\text{C}$ operating temperature range, and $\pm 3\%$ output voltage tolerance over the entire output current, input voltage, and temperature range. The LM2936EP is available in a TO-92 package, a SO-8 surface mount package, and a TO-252 surface mount power package.

ENHANCED PLASTIC

- Extended Temperature Performance of -40°C to $+125^{\circ}\text{C}$
- Baseline Control - Single Fab & Assembly Site
- Process Change Notification (PCN)
- Qualification & Reliability Data
- Solder (PbSn) Lead Finish is standard
- Enhanced Diminishing Manufacturing Sources (DMS) Support

Features

- Ultra low quiescent current ($I_Q \leq 15 \mu\text{A}$ for $I_O = 100 \mu\text{A}$)
- Fixed 5V, 50 mA output
- $\pm 2\%$ Initial output tolerance
- $\pm 3\%$ Output tolerance over line, load, and temperature
- Dropout voltage typically 200 mV @ $I_O = 50 \text{ mA}$
- Reverse battery protection
- -50V reverse transient protection
- Internal short circuit current limit
- Internal thermal shutdown protection
- 40V operating voltage limit
- 60V operating voltage limit for LM2936HVEP
- Shutdown Pin available with LM2936BMEP package

Applications

- Selected Military Applications
- Selected Avionics Applications

Ordering Information

PART NUMBER	VID PART NUMBER	NS PACKAGE NUMBER (Note 3)
LM2936MX-5.0EP	V62/4636-01	M08A
(Notes 1, 2)	TBD	TBD

Note 1: For the following (Enhanced Plastic) versions, check for availability: LM2936BM-5.0EP, LM2936HVBMA50EP, LM2936HVMA50EP, LM2936M-5.0EP, LM2936BMX50EP, LM2936HVBMAX5EP, LM2936HVMAX5EP, LM2936MP-5.0EP, LM2936MPX50EP, LM2936MM-5.0EP, LM2936MMX50EP, LM2936DT-5.0EP, LM2936DTX50EP, LM2936Z-5.0EP. Parts listed with an "X" are provided in Tape & Reel and parts without an "X" are in Rails.

Note 2: FOR ADDITIONAL ORDERING AND PRODUCT INFORMATION, PLEASE VISIT THE ENHANCED PLASTIC WEB SITE AT: www.national.com/mil

Note 3: Refer to package details under Physical Dimensions

Typical Application

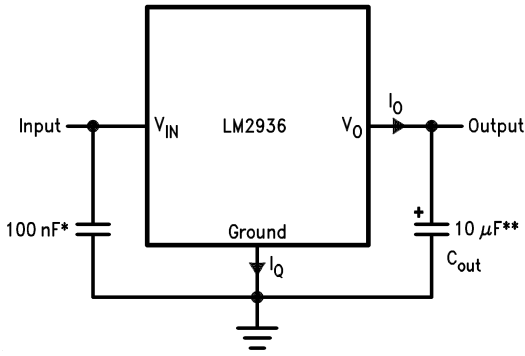

20090701

* Required if regulator is located more than 2" from power supply filter capacitor.

** Required for stability. Must be rated for 10 μF minimum over intended operating temperature range. Effective series resistance (ESR) is critical, see curve. Locate capacitor as close as possible to the regulator output and ground pins. Capacitance may be increased without bound.

Connection Diagrams

TO-252

TAB is GND

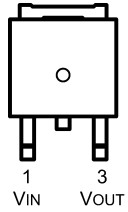

20090725

Top View

See NS Package Number TD03B

SOT-223

TAB is GND

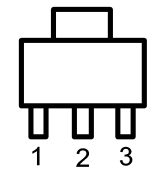

20090726

Top View

See NS Package Number MA04A

8-Pin SO (M)

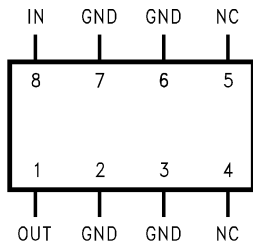

20090706

Top View

See NS Package Number M08A

8-Pin SO (M)

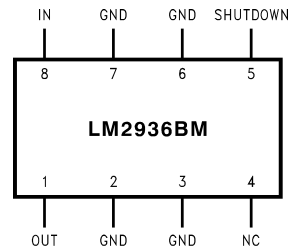

20090727

Top View

See NS Package Number M08A

TO-92

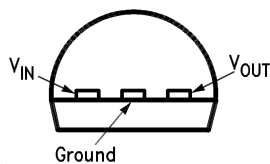

20090702

Bottom View

See NS Package Number Z03A

8-Pin Mini SOIC (MM)

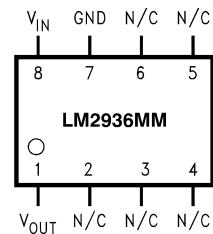

20090728

Top View

See NS Package Number MUA08A

Absolute Maximum Ratings (Note 4)

If Military/Aerospace specified devices are required, please contact the National Semiconductor Sales Office/Distributors for availability and specifications.

Input Voltage (Survival)	+60V, -50V
ESD Susceptibility (Note 5)	2000V
Power Dissipation (Note 6)	Internally limited
Junction Temperature (T _{Jmax})	150°C
Storage Temperature Range	-65°C to +150°C
Lead Temperature (Soldering, 10 sec.)	260°C

Maximum Operating Input Voltage - LM2936EP	+40V
Maximum Operating Input Voltage - LM2936HVEP only	+60V
Maximum Shutdown Pin Voltage - LM2936BMEP only	0V to 40V
TO-92 (Z03A) θ _{JA}	195°C/W
MSO-8 (MUA08A) θ _{JA}	200°C/W
SO-8 (M08A) θ _{JA}	140°C/W
SO-8 (M08A) θ _{JC}	45°C/W
TO-252 (TD03B) θ _{JA}	136°C/W
TO-252 (TD03B) θ _{JC}	6°C/W
SOT-223 (MA04A) θ _{JA}	149°C/W
SOT-223 (MA04A) θ _{JC}	36°C/W

Operating Ratings

Operating Temperature Range	-40°C to +125°C
-----------------------------	-----------------

Electrical Characteristics

V_{IN} = 14V, I_O = 10 mA, T_J = 25°C, unless otherwise specified. **Boldface** limits apply over entire operating temperature range

Parameter	Conditions	Min (Note 8)	Typical (Note 7)	Max (Note 8)	Units
LM2936HVEP Only					
Output Voltage	5.5V ≤ V _{IN} ≤ 48V, 100 μA ≤ I _O ≤ 50 mA (Note 9)	4.85	5.00	5.15	V
Line Regulation	6V ≤ V _{IN} ≤ 60V, I _O = 1mA		15	35	mV
All LM2936EP					
Output Voltage	5.5V ≤ V _{IN} ≤ 26V, 100 μA ≤ I _O ≤ 50 mA (Note 9)	4.85	5.00	5.10	V
Quiescent Current	I _O = 100 μA, 8V ≤ V _{IN} ≤ 24V		9	15	μA
	I _O = 10 mA, 8V ≤ V _{IN} ≤ 24V		0.20	0.50	mA
	I _O = 50 mA, 8V ≤ V _{IN} ≤ 24V		1.5	2.5	mA
Line Regulation	9V ≤ V _{IN} ≤ 16V		5	10	mV
	6V ≤ V _{IN} ≤ 40V, I _O = 1 mA		10	30	mV
Load Regulation	100 μA ≤ I _O ≤ 5 mA		10	30	mV
	5 mA ≤ I _O ≤ 50 mA		10	30	mV
Dropout Voltage	I _O = 100 μA		0.05	0.10	V
	I _O = 50 mA		0.20	0.40	V
Short Circuit Current	V _O = 0V	65	120	250	mA
Output Impedance	I _O = 30 mAdc and 10 mArms, f = 1000 Hz		450		mΩ
Output Noise Voltage	10 Hz–100 kHz		500		μV
Long Term Stability			20		mV/1000 Hr
Ripple Rejection	V _{ripple} = 1V _{rms} , f _{ripple} = 120 Hz	-40	-60		dB
Reverse Polarity Transient Input Voltage	R _L = 500Ω, T = 1 ms	-50	-80		V
Output Voltage with Reverse Polarity Input	V _{IN} = -15V, R _L = 500Ω		0.00	-0.30	V
Maximum Line Transient	R _L = 500Ω, V _O ≤ 5.5V, T = 40ms	60			V

Electrical Characteristics (Continued)

$V_{IN} = 14V$, $I_O = 10\text{ mA}$, $T_J = 25^\circ\text{C}$, unless otherwise specified. **Boldface** limits apply over entire operating temperature range

Parameter	Conditions	Min (Note 8)	Typical (Note 7)	Max (Note 8)	Units
Output Bypass Capacitance (C_{OUT}) ESR	$C_{OUT} = 10\mu\text{F}$ $0.1\text{ mA} \leq I_{OUT} \leq 50\text{ mA}$	0.3		8	Ω
Shutdown Input – LM2936BMEP Only					
Output Voltage, V_{OUT}	Output Off, $V_{SD}=2.4V$, $R_{LOAD} = 500\Omega$		0	0.010	V
Shutdown High Threshold Voltage, V_{IH}	Output Off, $R_{LOAD} = 500\Omega$	2.00	1.1		V
Shutdown Low Threshold Voltage, V_{IL}	Output On, $R_{LOAD} = 500\Omega$		1.1	0.60	V
Shutdown High Current, I_{IH}	Output Off, $V_{SD} = 2.4V$, $R_{LOAD} = 500\Omega$		12		μA
Quiescent Current	Output Off, $V_{SD} = 2.4V$, $R_{LOAD} = 500\Omega$ Includes I_{IH} Current		30		μA

Note 4: Absolute Maximum Ratings indicate limits beyond which damage to the device may occur. DC and AC electrical specifications do not apply when operating the device beyond its specified operating ratings.

Note 5: Human body model, 100 pF discharge through a 1.5 k Ω resistor.

Note 6: The maximum power dissipation is a function of T_{Jmax} , θ_{JA} , and T_A . The maximum allowable power dissipation at any ambient temperature is $P_D = (T_{Jmax} - T_A)/\theta_{JA}$. If this dissipation is exceeded, the die temperature will rise above 150°C and the LM2936EP will go into thermal shutdown.

Note 7: Typicals are at 25°C (unless otherwise specified) and represent the most likely parametric norm.

Note 8: Datasheet min/max specification limits are guaranteed by design, test, or statistical analysis.

Note 9: To ensure constant junction temperature, pulse testing is used.

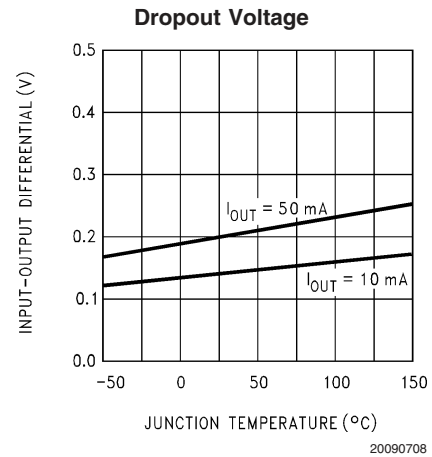
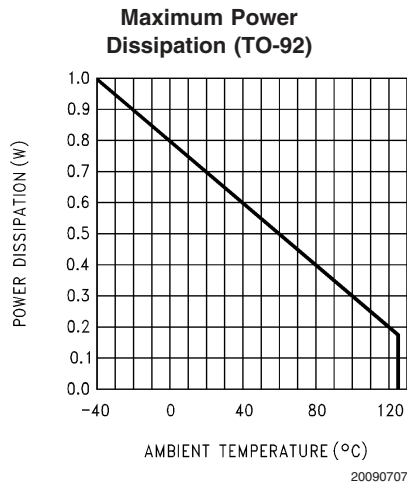
Typical Performance Characteristics

Typical Performance Characteristics (Continued)

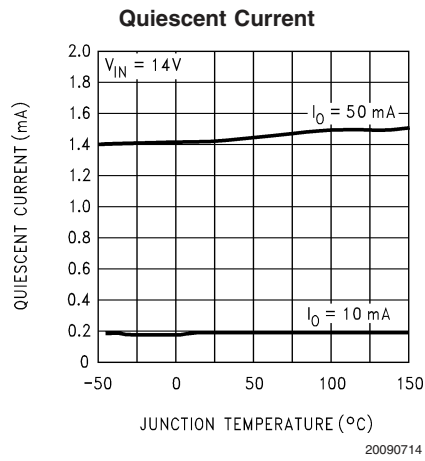
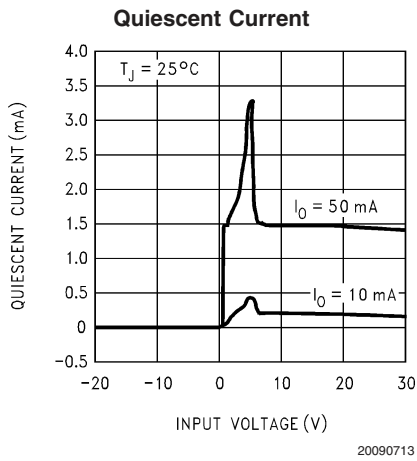
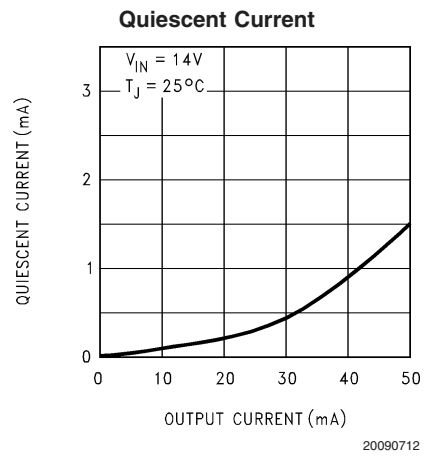
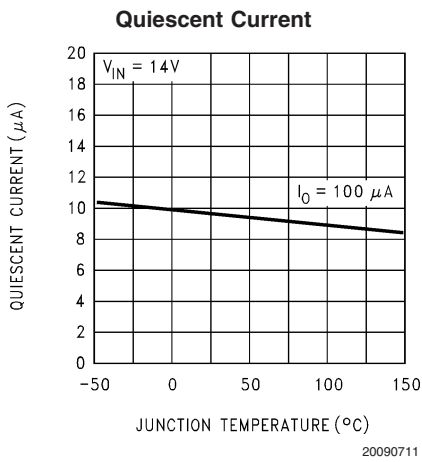
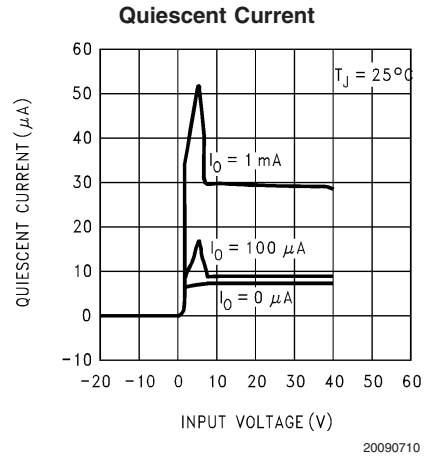
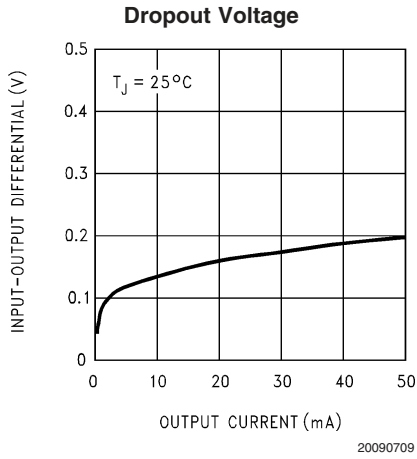

Typical Performance Characteristics (Continued)

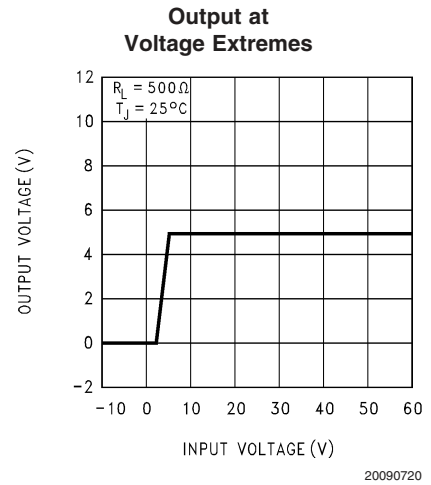
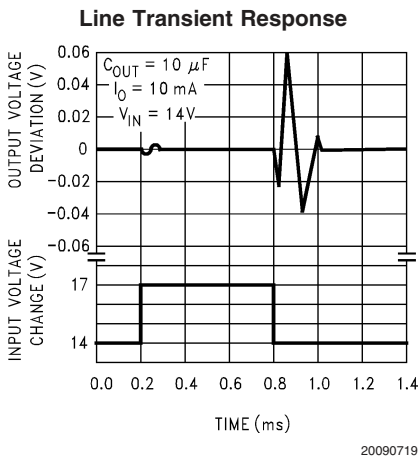
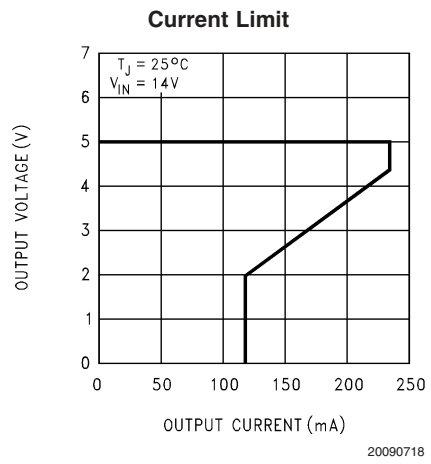
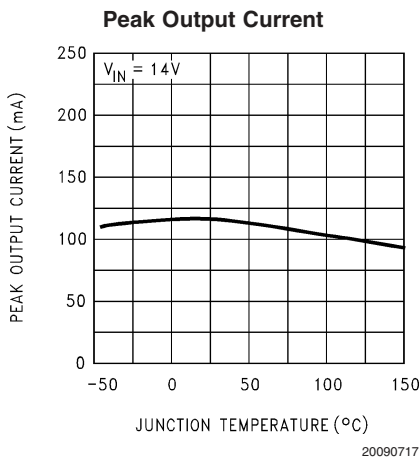
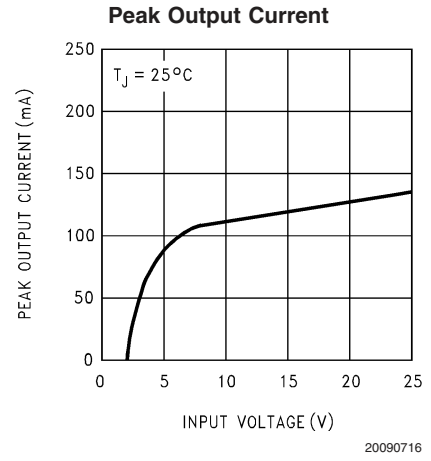
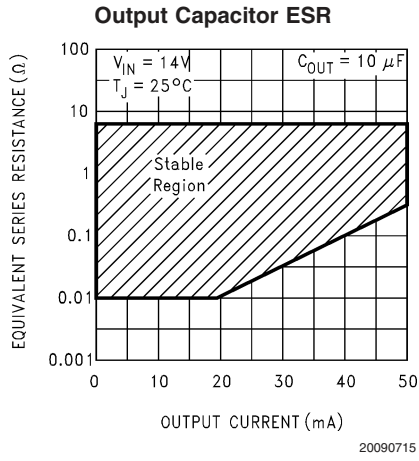

Typical Performance Characteristics (Continued)

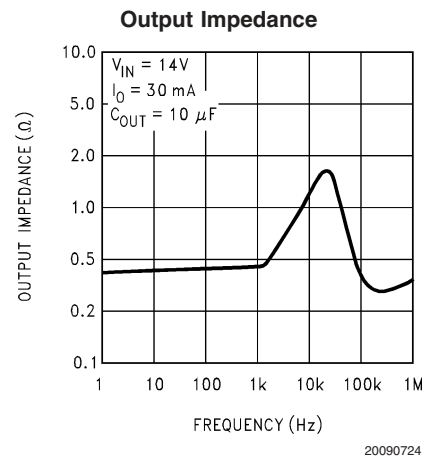
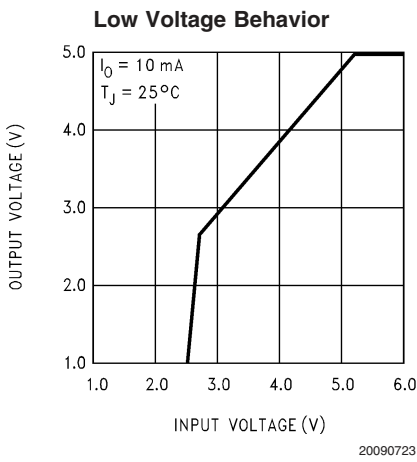
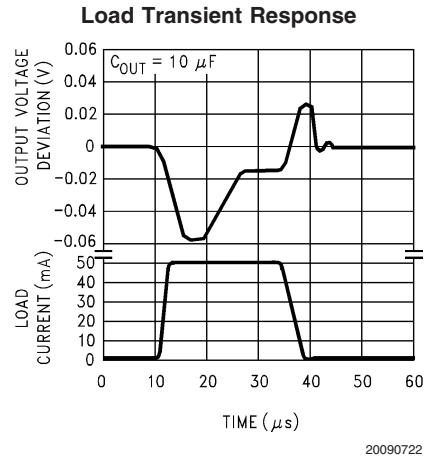
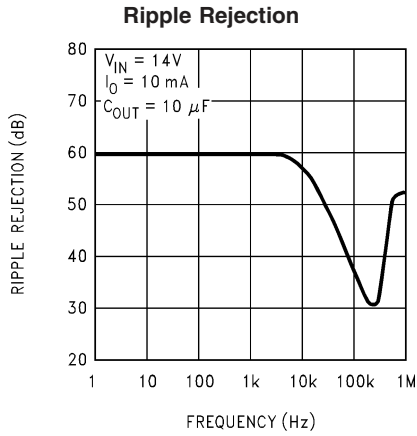

Applications Information

Unlike other PNP low dropout regulators, the LM2936EP remains fully operational to 40V. Owing to power dissipation characteristics of the available packages, full output current cannot be guaranteed for all combinations of ambient temperature and input voltage. As an example, consider an LM2936ZEP operating at 25°C ambient. Using the formula for maximum allowable power dissipation given in (Note 6) , we find that $P_{Dmax} = 641 \text{ mW}$ at 25°C. Including the small contribution of the quiescent current to total power dissipation the maximum input voltage (while still delivering 50 mA output current) is 17.3V. The LM2936ZEP will go into thermal shutdown if it attempts to deliver full output current with an input voltage of more than 17.3V. Similarly, at 40V input and 25°C ambient the LM2936ZEP can deliver 18 mA maximum.

Under conditions of higher ambient temperatures, the voltage and current calculated in the previous examples will drop. For instance, at the maximum ambient of 125°C the LM2936ZEP can only dissipate 128 mW, limiting the input voltage to 7.34V for a 50 mA load, or 3.5 mA output current for a 40V input.

The junction to ambient thermal resistance θ_{JA} rating has two distinct components: the junction to case thermal resistance rating θ_{JC} ; and the case to ambient thermal resistance rating θ_{CA} . The relationship is defined as: $\theta_{JA} = \theta_{JC} + \theta_{CA}$.

For the SO-8 and TO-252 surface mount packages the θ_{JA} rating can be improved by using the copper mounting pads on the printed circuit board as a thermal conductive path to extract heat from the package.

On the SO-8 package the four ground pins are thermally connected to the backside of the die. Adding approximately

0.04 square inches of 2 oz. copper pad area to these four pins will improve the θ_{JA} rating to approximately 110°C/W. If this extra pad are is placed directly beneath the package there should not be any impact on board density.

On the TO-252 package the ground tab is thermally connected to the backside of the die. Adding 1 square inch of 2 oz. copper pad area directly under the ground tab will improve the θ_{JA} rating to approximately 50°C/W.

While the LM2936EP has an internally set thermal shutdown point of typically 150°C, this is intended as a safety feature only. Continuous operation near the thermal shutdown temperature should be avoided as it may have a negative affect on the life of the device.

While the LM2936EP maintains regulation to 60V, it will not withstand a short circuit above 40V because of safe operating area limitations in the internal PNP pass device. Above 60V the LM2936EP will break down with catastrophic effects on the regulator and possibly the load as well. Do not use this device in a design where the input operating voltage may exceed 40V, or where transients are likely to exceed 60V.

Shutdown Pin

The LM2936BMEP has a pin for shutting down the regulator output. Applying a Logic Level High (>2.0V) to the Shutdown pin will cause the output to turn off. Leaving the Shutdown pin open, connecting it to Ground, or applying a Logic Level Low (<0.6V) will allow the regulator output to turn on.

Physical Dimensions inches (millimeters) unless otherwise noted

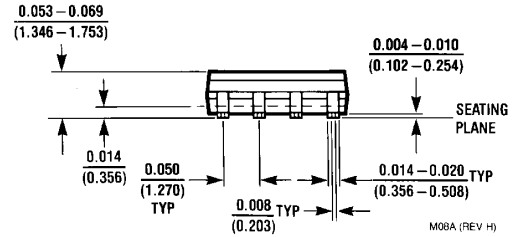
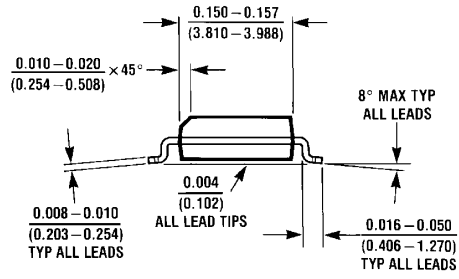
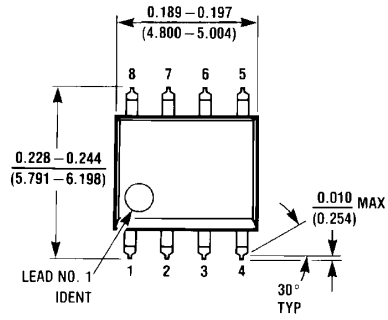

**8-Lead Small Outline Molded Package (M)
NS Package Number M08A**

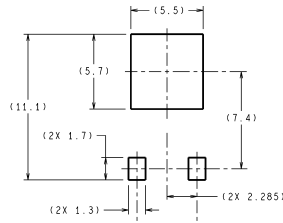

DIMENSIONS ARE IN MILLIMETERS

LAND PATTERN RECOMMENDATION

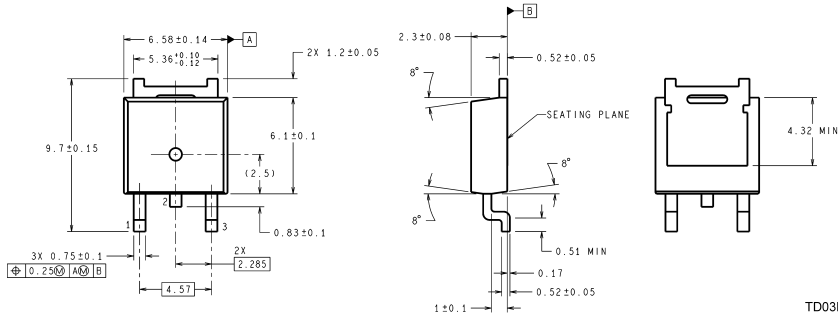

**TO-252 Package (DT)
NS Package Number TD03B**

Physical Dimensions inches (millimeters) unless otherwise noted (Continued)

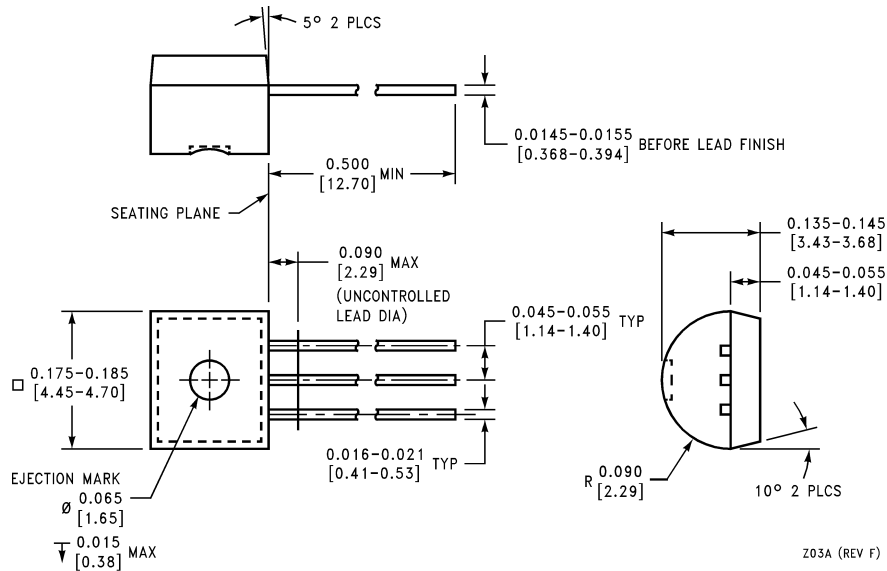

3-Lead TO-92 Plastic Package (Z)
NS Package Number Z03A

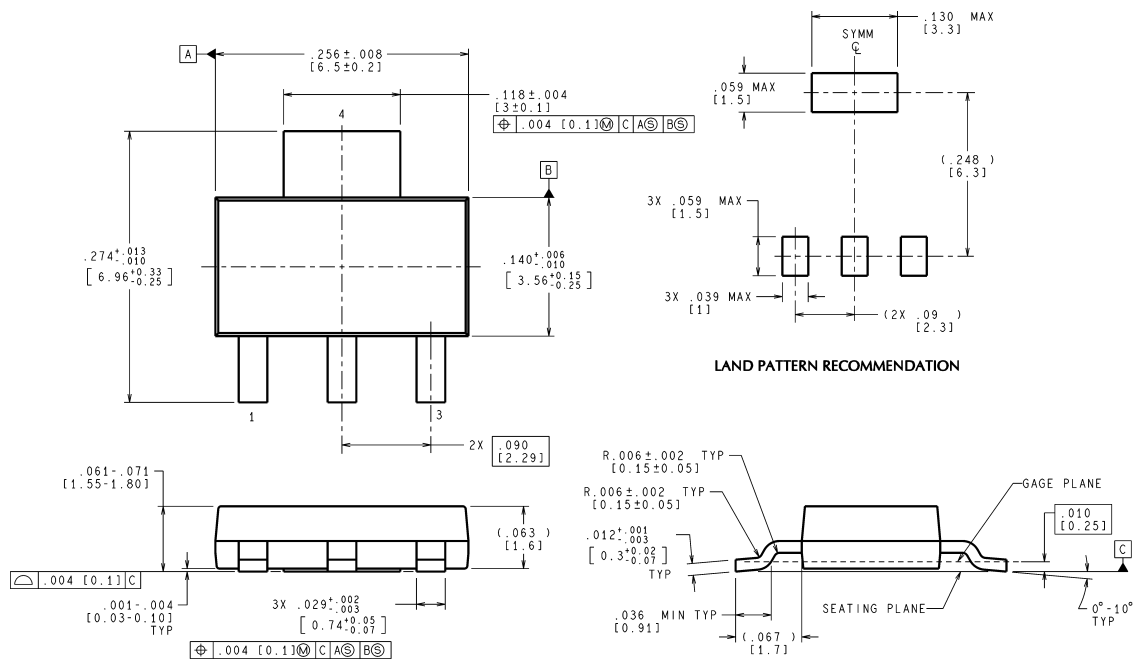

SOT-223 Package (MP)
NS Package Number MA04A

Physical Dimensions inches (millimeters) unless otherwise noted (Continued)

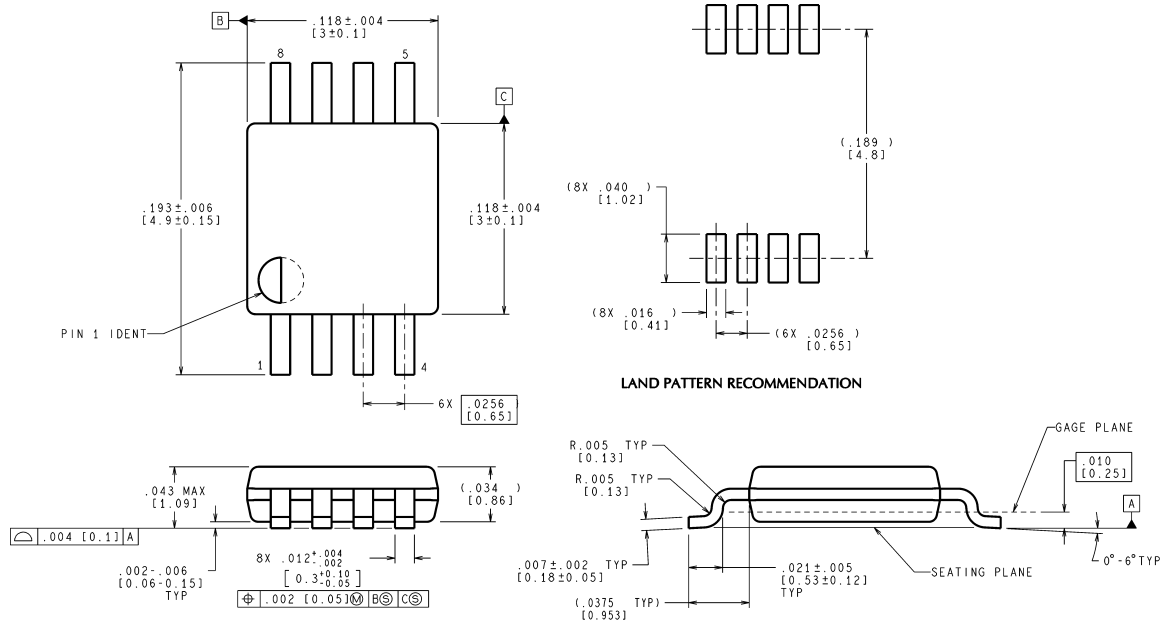

CONTROLLING DIMENSION IS INCH
VALUES IN [] ARE MILLIMETERS

MUA08A (Rev E)

**8-Lead Mini SOIC package (MM)
NS Package Number MUA08A**

LIFE SUPPORT POLICY

NATIONAL'S PRODUCTS ARE NOT AUTHORIZED FOR USE AS CRITICAL COMPONENTS IN LIFE SUPPORT DEVICES OR SYSTEMS WITHOUT THE EXPRESS WRITTEN APPROVAL OF THE PRESIDENT AND GENERAL COUNSEL OF NATIONAL SEMICONDUCTOR CORPORATION. As used herein:

1. Life support devices or systems are devices or systems which, (a) are intended for surgical implant into the body, or (b) support or sustain life, and whose failure to perform when properly used in accordance with instructions for use provided in the labeling, can be reasonably expected to result in a significant injury to the user.
2. A critical component is any component of a life support device or system whose failure to perform can be reasonably expected to cause the failure of the life support device or system, or to affect its safety or effectiveness.

BANNED SUBSTANCE COMPLIANCE

National Semiconductor certifies that the products and packing materials meet the provisions of the Customer Products Stewardship Specification (CSP-9-111C2) and the Banned Substances and Materials of Interest Specification (CSP-9-111S2) and contain no "Banned Substances" as defined in CSP-9-111S2.



National Semiconductor
Americas Customer
Support Center
Email: new.feedback@nsc.com
Tel: 1-800-272-9959

National Semiconductor
Europe Customer Support Center
Fax: +49 (0) 180-530 85 86
Email: europe.support@nsc.com
Deutsch Tel: +49 (0) 69 9508 6208
English Tel: +44 (0) 870 24 0 2171
Français Tel: +33 (0) 1 41 91 8790

National Semiconductor
Asia Pacific Customer
Support Center
Email: ap.support@nsc.com

National Semiconductor
Japan Customer Support Center
Fax: 81-3-5639-7507
Email: jpn.feedback@nsc.com
Tel: 81-3-5639-7560

www.national.com