

## LM4050

# Precision Micropower Shunt Voltage Reference

### General Description

Ideal for space critical applications, the LM4050 precision voltage reference is available in the sub-miniature (3 mm x 1.3 mm) SOT-23 surface-mount package. The LM4050's design eliminates the need for an external stabilizing capacitor while ensuring stability with any capacitive load, thus making the LM4050 easy to use. Further reducing design effort is the availability of several fixed reverse breakdown voltages: 2.048V, 2.500V, 4.096V, 5.000V, 8.192V, and 10.000V. The minimum operating current increases from 60  $\mu$ A for the LM4050-2.0 to 100  $\mu$ A for the LM4050-10.0. All versions have a maximum operating current of 15 mA.

The LM4050 utilizes fuse and zener-zap reverse breakdown voltage trim during wafer sort to ensure that the prime parts have an accuracy of better than  $\pm 0.1\%$  (A grade) at 25°C. Bandgap reference temperature drift curvature correction and low dynamic impedance ensure stable reverse breakdown voltage accuracy over a wide range of operating temperatures and currents.

All grades and voltage options of the LM4050 are available in both an industrial temperature range (-40°C and +85°C) and an extended temperature range (-40°C and +125°C).

### Features

- Small packages: SOT-23
- No output capacitor required

- Tolerates capacitive loads
- Fixed reverse breakdown voltages of 2.048V, 2.500V, 4.096V, 5.000V, 8.192V, and 10.000V

### Key Specifications (LM4050-2.5)

- |   |                                 |
|---|---------------------------------|
| ■ Output voltage tolerance<br>(A grade, 25°C) | $\pm 0.1\%$ (max)               |
| ■ Low output noise<br>(10 Hz to 10 kHz)       | 41 $\mu$ V <sub>rms</sub> (typ) |
| ■ Wide operating current range                | 60 $\mu$ A to 15 mA             |
| ■ Industrial temperature range                | -40°C to +85°C                  |
| ■ Extended temperature range                  | -40°C to +125°C                 |
| ■ Low temperature coefficient                 | 50 ppm/°C (max)                 |

### Applications

- Portable, Battery-Powered Equipment
- Data Acquisition Systems
- Instrumentation
- Process Control
- Energy Management
- Product Testing
- Automotive
- Precision Audio Components

### Connection Diagram

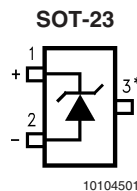

\*This pin must be left floating or connected to pin 2.

Top View  
See NS Package Number MF03A

## Ordering Information

### Industrial Temperature Range (–40°C to +85°C)

Reverse Breakdown Voltage Tolerance at 25°C and Average Reverse Breakdown Voltage Temperature Coefficient	LM4050 Supplied as 1000 Units, Tape and Reel	LM4050 Supplied as 3000 Units, Tape and Reel
±0.1%, 50 ppm/°C max (A grade)	LM4050AIM3-2.0	LM4050AIM3X-2.0
	LM4050AIM3-2.5	LM4050AIM3X-2.5
	LM4050AIM3-4.1	LM4050AIM3X-4.1
	LM4050AIM3-5.0	LM4050AIM3X-5.0
	LM4050AIM3-8.2	LM4050AIM3X-8.2
	LM4050AIM3-10	LM4050AIM3X-10
±0.2%, 50 ppm/°C max (B grade)	LM4050BIM3-2.0	LM4050BIM3X-2.0
	LM4050BIM3-2.5	LM4050BIM3X-2.5
	LM4050BIM3-4.1	LM4050BIM3X-4.1
	LM4050BIM3-5.0	LM4050BIM3X-5.0
	LM4050BIM3-8.2	LM4050BIM3X-8.2
	LM4050BIM3-10	LM4050BIM3X-10
±0.5%, 50 ppm/°C max (C grade)	LM4050CIM3-2.0	LM4050CIM3X-2.0
	LM4050CIM3-2.5	LM4050CIM3X-2.5
	LM4050CIM3-4.1	LM4050CIM3X-4.1
	LM4050CIM3-5.0	LM4050CIM3X-5.0
	LM4050CIM3-8.2	LM4050CIM3X-8.2
	LM4050CIM3-10	LM4050CIM3X-10

### Extended Temperature Range (–40°C to +125°C)

Reverse Breakdown Voltage Tolerance at 25°C and Average Reverse Breakdown Voltage Temperature Coefficient	LM4050 Supplied as 1000 Units, Tape and Reel	LM4050 Supplied as 3000 Units, Tape and Reel
±0.1%, 50 ppm/°C max (A grade)	LM4050AEM3-2.0	LM4050AEM3X-2.0
	LM4050AEM3-2.5	LM4050AEM3X-2.5
	LM4050AEM3-4.1	LM4050AEM3X-4.1
	LM4050AEM3-5.0	LM4050AEM3X-5.0
	LM4050AEM3-8.2	LM4050AEM3X-8.2
	LM4050AEM3-10	LM4050AEM3X-10
±0.2%, 50 ppm/°C max (B grade)	LM4050BEM3-2.0	LM4050BEM3X-2.0
	LM4050BEM3-2.5	LM4050BEM3X-2.5
	LM4050BEM3-4.1	LM4050BEM3X-4.1
	LM4050BEM3-5.0	LM4050BEM3X-5.0
	LM4050BEM3-8.2	LM4050BEM3X-8.2
	LM4050BEM3-10	LM4050BEM3X-10
±0.5%, 50 ppm/°C max (C grade)	LM4050CEM3-2.0	LM4050CEM3X-2.0
	LM4050CEM3-2.5	LM4050CEM3X-2.5
	LM4050CEM3-4.1	LM4050CEM3X-4.1
	LM4050CEM3-5.0	LM4050CEM3X-5.0
	LM4050CEM3-8.2	LM4050CEM3X-8.2
	LM4050CEM3-10	LM4050CEM3X-10

## SOT-23 Package Marking Information

Only three fields of marking are possible on the SOT-23's small surface. This table gives the meaning of the three fields.

Part Marking	Field Definition
RCA	First Field: R = Reference  Second Field: N = 2.048V Voltage Option C = 2.500V Voltage Option D = 4.096V Voltage Option E = 5.000V Voltage Option F = 8.192V Voltage Option G = 10.000V Voltage Option
RDA	
REA	
RFA	
RGA	
RNA	
RCB	Third Field:  A–C = Initial Reverse Breakdown Voltage or Reference Voltage Tolerance A = $\pm 0.1\%$ , B = $\pm 0.2\%$ , C = $+0.5\%$ ,
RDB	
REB	
RFB	
RGB	
RNB	
RCC	
RDC	
REC	
RFC	
RGC	
RNC	

**Absolute Maximum Ratings** (Note 1)

If Military/Aerospace specified devices are required, please contact the National Semiconductor Sales Office/Distributors for availability and specifications.

Reverse Current	20 mA
Forward Current	10 mA
Power Dissipation ( $T_A = 25^\circ\text{C}$ ) (Note 2)	
M3 Package	280 mW
Storage Temperature	$-65^\circ\text{C}$ to $+150^\circ\text{C}$
Lead Temperature	
M3 Package	
Vapor phase (60 seconds)	$+215^\circ\text{C}$
Infrared (15 seconds)	$+220^\circ\text{C}$
ESD Susceptibility	
Human Body Model (Note 3)	2 kV
Machine Model (Note 3)	200V

See AN-450 "Surface Mounting Methods and Their Effect on Product Reliability" for other methods of soldering surface mount devices.

**LM4050-2.0**  
**Electrical Characteristics**

**Boldface limits apply for  $T_A = T_J = T_{\text{MIN}}$  to  $T_{\text{MAX}}$** ; all other limits  $T_A = T_J = 25^\circ\text{C}$ . The grades A, B and C designate initial Reverse Breakdown Voltage tolerances of  $\pm 0.1\%$ ,  $\pm 0.2\%$ , and  $0.5\%$  respectively.

Symbol	Parameter	Conditions	Typical (Note 4)	LM4050AIM3 LM4050AEM3 Limits (Note 5)	LM4050BIM3 LM4050BEM3 Limits (Note 5)	LM4050CIM3 LM4050CEM3 Limits (Note 5)	Units (Limit)
$V_R$	Reverse Breakdown Voltage	$I_R = 100 \mu\text{A}$	2.048				V
	Reverse Breakdown Voltage Tolerance (Note 6)	$I_R = 100 \mu\text{A}$		$\pm 2.048$	$\pm 4.096$	$\pm 10.24$	mV (max)
		Industrial Temp. Range			<b><math>\pm 9.0112</math></b>	<b><math>\pm 11.4688</math></b>	<b><math>\pm 14.7456</math></b>
	Extended Temp. Range			<b><math>\pm 12.288</math></b>	<b><math>\pm 14.7456</math></b>	<b><math>\pm 17.2032</math></b>	mV (max)
$I_{\text{RMIN}}$	Minimum Operating Current		41				$\mu\text{A}$
				60	60	60	$\mu\text{A}$ (max)
				<b>65</b>	<b>65</b>	<b>65</b>	$\mu\text{A}$ (max)
$\Delta V_R/\Delta T$	Average Reverse Breakdown Voltage Temperature Coefficient (Note 6)	$I_R = 10 \text{ mA}$	$\pm 20$				ppm/ $^\circ\text{C}$
		$I_R = 1 \text{ mA}$	$\pm 15$				ppm/ $^\circ\text{C}$
		$I_R = 100 \mu\text{A}$	$\pm 15$	<b><math>\pm 50</math></b>	<b><math>\pm 50</math></b>	<b><math>\pm 50</math></b>	ppm/ $^\circ\text{C}$ (max)
$\Delta V_R/\Delta I_R$	Reverse Breakdown Voltage Change with Operating Current Change (Note 7)	$I_{\text{RMIN}} \leq I_R \leq 1 \text{ mA}$	0.3				mV
				0.8	0.8	0.8	mV (max)
				<b>1.2</b>	<b>1.2</b>	<b>1.2</b>	mV (max)
		$1 \text{ mA} \leq I_R \leq 15 \text{ mA}$	2.3				mV
				6.0	6.0	6.0	mV (max)
				<b>8.0</b>	<b>8.0</b>	<b>8.0</b>	mV (max)
$Z_R$	Reverse Dynamic Impedance	$I_R = 1 \text{ mA}$ , $f = 120 \text{ Hz}$ , $I_{\text{AC}} = 0.1 I_R$	0.3				$\Omega$
$e_N$	Wideband Noise	$I_R = 100 \mu\text{A}$ $10 \text{ Hz} \leq f \leq 10 \text{ kHz}$	34				$\mu\text{V}_{\text{rms}}$
$\Delta V_R$	Reverse Breakdown Voltage Long Term Stability	$t = 1000 \text{ hrs}$ $T = 25^\circ\text{C} \pm 0.1^\circ\text{C}$ $I_R = 100 \mu\text{A}$	120				ppm
$V_{\text{HYST}}$	Thermal Hysteresis (Note 8)	$\Delta T = -40^\circ\text{C}$ to $125^\circ\text{C}$	0.7				mV

**Operating Ratings** (Note 2)

Temperature Range	$(T_{\text{min}} \leq T_A \leq T_{\text{max}})$
Industrial Temperature Range	$-40^\circ\text{C} \leq T_A \leq +85^\circ\text{C}$
Extended temperature Range	$-40^\circ\text{C} \leq T_A \leq +125^\circ\text{C}$
Reverse Current	
LM4050-2.0	60 $\mu\text{A}$ to 15 mA
LM4050-2.5	60 $\mu\text{A}$ to 15 mA
LM4050-4.1	68 $\mu\text{A}$ to 15 mA
LM4050-5.0	74 $\mu\text{A}$ to 15 mA
LM4050-8.2	91 $\mu\text{A}$ to 15 mA
LM4050-10.0	100 $\mu\text{A}$ to 15 mA

## LM4050-2.5 Electrical Characteristics

**Boldface limits apply for  $T_A = T_J = T_{MIN}$  to  $T_{MAX}$** ; all other limits  $T_A = T_J = 25^\circ\text{C}$ . The grades A, B and C designate initial Reverse Breakdown Voltage tolerances of  $\pm 0.1\%$ ,  $\pm 0.2\%$ , and  $0.5\%$  respectively.

Symbol	Parameter	Conditions	Typical (Note 4)	LM4050AIM3 LM4050AEM3 Limits (Note 5)	LM4050BIM3 LM4050BEM3 Limits (Note 5)	LM4050CIM3 LM4050CEM3 Limits (Note 5)	Units (Limit)
$V_R$	Reverse Breakdown Voltage	$I_R = 100 \mu\text{A}$	2.500				V
	Reverse Breakdown Voltage Tolerance (Note 6)	$I_R = 100 \mu\text{A}$		$\pm 2.5$	$\pm 5.0$	$\pm 13$	mV (max)
		Industrial Temp. Range		<b><math>\pm 11</math></b>	<b><math>\pm 14</math></b>	<b><math>\pm 21</math></b>	mV (max)
	Extended Temp. Range		<b><math>\pm 15</math></b>	<b><math>\pm 18</math></b>	<b><math>\pm 25</math></b>	mV (max)	
$I_{RMIN}$	Minimum Operating Current		41				$\mu\text{A}$
				60	60	60	$\mu\text{A}$ (max)
				<b>65</b>	<b>65</b>	<b>65</b>	$\mu\text{A}$ (max)
$\Delta V_R/\Delta T$	Average Reverse Breakdown Voltage Temperature Coefficient (Note 6)	$I_R = 10 \text{ mA}$	$\pm 20$				ppm/ $^\circ\text{C}$
		$I_R = 1 \text{ mA}$	$\pm 15$				ppm/ $^\circ\text{C}$
		$I_R = 100 \mu\text{A}$	$\pm 15$	<b><math>\pm 50</math></b>	<b><math>\pm 50</math></b>	<b><math>\pm 50</math></b>	ppm/ $^\circ\text{C}$ (max)
$\Delta V_R/\Delta I_R$	Reverse Breakdown Voltage Change with Operating Current Change (Note 7)	$I_{RMIN} \leq I_R \leq 1 \text{ mA}$	0.3				mV
				0.8	0.8	0.8	mV (max)
				<b>1.2</b>	<b>1.2</b>	<b>1.2</b>	mV (max)
		$1 \text{ mA} \leq I_R \leq 15 \text{ mA}$	2.3				mV
				6.0	6.0	6.0	mV (max)
		<b>8.0</b>	<b>8.0</b>	<b>8.0</b>	mV (max)		
$Z_R$	Reverse Dynamic Impedance	$I_R = 1 \text{ mA}$ , $f = 120 \text{ Hz}$ , $I_{AC} = 0.1 I_R$	0.3				$\Omega$
$e_N$	Wideband Noise	$I_R = 100 \mu\text{A}$ $10 \text{ Hz} \leq f \leq 10 \text{ kHz}$	41				$\mu\text{V}_{rms}$
$\Delta V_R$	Reverse Breakdown Voltage Long Term Stability	$t = 1000 \text{ hrs}$ $T = 25^\circ\text{C} \pm 0.1^\circ\text{C}$ $I_R = 100 \mu\text{A}$	120				ppm
$V_{HYST}$	Thermal Hysteresis (Note 8)	$\Delta T = -40^\circ\text{C}$ to $125^\circ\text{C}$	0.7				mV

## LM4050-4.1 Electrical Characteristics

**Boldface limits apply for  $T_A = T_J = T_{MIN}$  to  $T_{MAX}$** ; all other limits  $T_A = T_J = 25^\circ\text{C}$ . The grades A, B and C designate initial Reverse Breakdown Voltage tolerances of  $\pm 0.1\%$ ,  $\pm 0.2\%$ , and  $0.5\%$  respectively.

Symbol	Parameter	Conditions	Typical (Note 4)	LM4050AIM3 LM4050AEM3 Limits (Note 5)	LM4050BIM3 LM4050BEM3 Limits (Note 5)	LM4050CIM3 LM4050CEM3 Limits (Note 5)	Units (Limit)
$V_R$	Reverse Breakdown Voltage	$I_R = 100 \mu\text{A}$	4.096				V
	Reverse Breakdown Voltage Tolerance (Note 6)	$I_R = 100 \mu\text{A}$		$\pm 4.1$	$\pm 8.2$	$\pm 21$	mV (max)
		Industrial Temp. Range		<b><math>\pm 18</math></b>	<b><math>\pm 22</math></b>	<b><math>\pm 34</math></b>	mV (max)
	Extended Temp. Range		<b><math>\pm 25</math></b>	<b><math>\pm 29</math></b>	<b><math>\pm 41</math></b>	mV (max)	
$I_{RMIN}$	Minimum Operating Current		52				$\mu\text{A}$
				68	68	68	$\mu\text{A}$ (max)
		Industrial Temp. Range		<b>73</b>	<b>73</b>	<b>73</b>	$\mu\text{A}$ (max)
	Extended Temp. Range		<b>78</b>	<b>78</b>	<b>78</b>	$\mu\text{A}$ (max)	
$\Delta V_R/\Delta T$	Average Reverse Breakdown Voltage Temperature Coefficient (Note 6)	$I_R = 10 \text{ mA}$	$\pm 30$				ppm/ $^\circ\text{C}$
		$I_R = 1 \text{ mA}$	$\pm 20$				ppm/ $^\circ\text{C}$
		$I_R = 100 \mu\text{A}$	$\pm 20$	<b><math>\pm 50</math></b>	<b><math>\pm 50</math></b>	<b><math>\pm 50</math></b>	ppm/ $^\circ\text{C}$ (max)
$\Delta V_R/\Delta I_R$	Reverse Breakdown Voltage Change with Operating Current Change (Note 7)	$I_{RMIN} \leq I_R \leq 1 \text{ mA}$	0.2				mV
				0.9	0.9	0.9	mV (max)
				<b>1.2</b>	<b>1.2</b>	<b>1.2</b>	mV (max)
		$1 \text{ mA} \leq I_R \leq 15 \text{ mA}$	2.0				mV
				7.0	7.0	7.0	mV (max)
		<b>10.0</b>	<b>10.0</b>	<b>10.0</b>	mV (max)		

**LM4050-4.1****Electrical Characteristics** (Continued)

**Boldface limits apply for  $T_A = T_J = T_{MIN}$  to  $T_{MAX}$** ; all other limits  $T_A = T_J = 25^\circ\text{C}$ . The grades A, B and C designate initial Reverse Breakdown Voltage tolerances of  $\pm 0.1\%$ ,  $\pm 0.2\%$ , and  $0.5\%$  respectively.

Symbol	Parameter	Conditions	Typical (Note 4)	LM4050AIM3 LM4050AEM3 Limits (Note 5)	LM4050BIM3 LM4050BEM3 Limits (Note 5)	LM4050CIM3 LM4050CEM3 Limits (Note 5)	Units (Limit)
$Z_R$	Reverse Dynamic Impedance	$I_R = 1 \text{ mA}$ , $f = 120 \text{ Hz}$ , $I_{AC} = 0.1 I_R$	0.5				$\Omega$
$e_N$	Wideband Noise	$I_R = 100 \mu\text{A}$ $10 \text{ Hz} \leq f \leq 10 \text{ kHz}$	93				$\mu\text{V}_{rms}$
$\Delta V_R$	Reverse Breakdown Voltage Long Term Stability	$t = 1000 \text{ hrs}$ $T = 25^\circ\text{C} \pm 0.1^\circ\text{C}$ $I_R = 100 \mu\text{A}$	120				ppm
$V_{HYST}$	Thermal Hysteresis (Note 8)	$\Delta T = -40^\circ\text{C}$ to $125^\circ\text{C}$	1.148				mV

**LM4050-5.0****Electrical Characteristics**

**Boldface limits apply for  $T_A = T_J = T_{MIN}$  to  $T_{MAX}$** ; all other limits  $T_A = T_J = 25^\circ\text{C}$ . The grades A, B and C designate initial Reverse Breakdown Voltage tolerances of  $\pm 0.1\%$ ,  $\pm 0.2\%$  and  $0.5\%$  respectively.

Symbol	Parameter	Conditions	Typical (Note 4)	LM4050AIM3 LM4050AEM3 Limits (Note 5)	LM4050BIM3 LM4050BEM3 Limits (Note 5)	LM4050CIM3 LM4050CEM3 Limits (Note 5)	Units (Limit)
$V_R$	Reverse Breakdown Voltage	$I_R = 100 \mu\text{A}$	5.000				V
	Reverse Breakdown Voltage Tolerance (Note 6)	$I_R = 100 \mu\text{A}$ Industrial Temp. Range		$\pm 5.0$	$\pm 10$	$\pm 25$	mV (max)
		Extended Temp. Range		<b><math>\pm 22</math></b>	<b><math>\pm 27</math></b>	<b><math>\pm 42</math></b>	mV (max)
$I_{RMIN}$	Minimum Operating Current		56				$\mu\text{A}$
		Industrial Temp. Range		74	74	74	$\mu\text{A}$ (max)
		Extended Temp. Range		<b>80</b>	<b>80</b>	<b>80</b>	$\mu\text{A}$ (max)
$\Delta V_R/\Delta T$	Average Reverse Breakdown Voltage Temperature Coefficient (Note 6)	$I_R = 10 \text{ mA}$	$\pm 30$				ppm/ $^\circ\text{C}$
		$I_R = 1 \text{ mA}$	$\pm 20$				ppm/ $^\circ\text{C}$
		$I_R = 100 \mu\text{A}$	$\pm 20$	<b><math>\pm 50</math></b>	<b><math>\pm 50</math></b>	<b><math>\pm 50</math></b>	ppm/ $^\circ\text{C}$ (max)
$\Delta V_R/\Delta I_R$	Reverse Breakdown Voltage Change with Operating Current Change (Note 7)	$I_{RMIN} \leq I_R \leq 1 \text{ mA}$	0.2				mV
				1.0	1.0	1.0	mV (max)
				<b>1.4</b>	<b>1.4</b>	<b>1.4</b>	mV (max)
		$1 \text{ mA} \leq I_R \leq 15 \text{ mA}$	2.0				mV
$Z_R$	Reverse Dynamic Impedance	$I_R = 1 \text{ mA}$ , $f = 120 \text{ Hz}$ , $I_{AC} = 0.1 I_R$	0.5				$\Omega$
							$\Omega$ (max)
$e_N$	Wideband Noise	$I_R = 100 \mu\text{A}$ $10 \text{ Hz} \leq f \leq 10 \text{ kHz}$	93				$\mu\text{V}_{rms}$
$\Delta V_R$	Reverse Breakdown Voltage Long Term Stability	$t = 1000 \text{ hrs}$ $T = 25^\circ\text{C} \pm 0.1^\circ\text{C}$ $I_R = 100 \mu\text{A}$	120				ppm
$V_{HYST}$	Thermal Hysteresis (Note 8)	$\Delta T = -40^\circ\text{C}$ to $125^\circ\text{C}$	1.4				mV

## LM4050-8.2

### Electrical Characteristics

**Boldface limits apply for  $T_A = T_J = T_{MIN}$  to  $T_{MAX}$** ; all other limits  $T_A = T_J = 25^\circ\text{C}$ . The grades A, B and C designate initial Reverse Breakdown Voltage tolerances of  $\pm 0.1\%$  and  $\pm 0.2\%$  and  $0.5\%$  respectively.

Symbol	Parameter	Conditions	Typical (Note 4)	LM4050AIM3 LM4050AEM3 Limits (Note 5)	LM4050BIM3 LM4050BEM3 Limits (Note 5)	LM4050CIM3 LM4050CEM3 Limits (Note 5)	Units (Limit)
$V_R$	Reverse Breakdown Voltage	$I_R = 150 \mu\text{A}$	8.192				V
	Reverse Breakdown Voltage Tolerance (Note 6)	$I_R = 150 \mu\text{A}$		$\pm 8.2$	$\pm 16$	$\pm 41$	mV (max)
		Industrial Temp. Range		<b><math>\pm 35</math></b>	<b><math>\pm 43</math></b>	<b><math>\pm 68</math></b>	mV (max)
	Extended Temp. Range		<b><math>\pm 49</math></b>	<b><math>\pm 57</math></b>	<b><math>\pm 82</math></b>	mV (max)	
$I_{RMIN}$	Minimum Operating Current		74				$\mu\text{A}$
		Industrial Temp. Range		91	91	91	$\mu\text{A}$ (max)
		Extended Temp. Range		<b>95</b>	<b>95</b>	<b>95</b>	$\mu\text{A}$ (max)
				<b>100</b>	<b>100</b>	<b>100</b>	$\mu\text{A}$ (max)
$\Delta V_R/\Delta T$	Average Reverse Breakdown Voltage Temperature Coefficient (Note 6)	$I_R = 10 \text{ mA}$	$\pm 40$				ppm/ $^\circ\text{C}$
		$I_R = 1 \text{ mA}$	$\pm 20$				ppm/ $^\circ\text{C}$
		$I_R = 150 \mu\text{A}$	$\pm 20$	<b><math>\pm 50</math></b>	<b><math>\pm 50</math></b>	<b><math>\pm 50</math></b>	ppm/ $^\circ\text{C}$ (max)
$\Delta V_R/\Delta I_R$	Reverse Breakdown Voltage Change with Operating Current Change (Note 7)	$I_{RMIN} \leq I_R \leq 1 \text{ mA}$	0.6				mV
				1.3	1.3	1.3	mV (max)
				<b>2.5</b>	<b>2.5</b>	<b>2.5</b>	mV (max)
		$1 \text{ mA} \leq I_R \leq 15 \text{ mA}$	7.0				mV
				10.0	10.0	10.0	mV (max)
		<b>18.0</b>	<b>18.0</b>	<b>18.0</b>	mV (max)		
$Z_R$	Reverse Dynamic Impedance	$I_R = 1 \text{ mA}$ , $f = 120 \text{ Hz}$ , $I_{AC} = 0.1 I_R$	0.6				$\Omega$
$e_N$	Wideband Noise	$I_R = 150 \mu\text{A}$ $10 \text{ Hz} \leq f \leq 10 \text{ kHz}$	150				$\mu\text{V}_{rms}$
$\Delta V_R$	Reverse Breakdown Voltage Long Term Stability	$t = 1000 \text{ hrs}$ $T = 25^\circ\text{C} \pm 0.1^\circ\text{C}$ $I_R = 150 \mu\text{A}$	120				ppm
$V_{HYST}$	Thermal Hysteresis (Note 8)	$\Delta T = -40^\circ\text{C}$ to $125^\circ\text{C}$	2.3				mV

## LM4050-10.0

### Electrical Characteristics

**Boldface limits apply for  $T_A = T_J = T_{MIN}$  to  $T_{MAX}$** ; all other limits  $T_A = T_J = 25^\circ\text{C}$ . The grades A, B and C designate initial Reverse Breakdown Voltage tolerances of  $\pm 0.1\%$  and  $\pm 0.2\%$  and  $0.5\%$  respectively.

Symbol	Parameter	Conditions	Typical (Note 4)	LM4050AIM3 LM4050AEM3 Limits (Note 5)	LM4050BIM3 LM4050BEM3 Limits (Note 5)	LM4050CIM3 LM4050CEM3 Limits (Note 5)	Units (Limit)
$V_R$	Reverse Breakdown Voltage	$I_R = 150 \mu\text{A}$	10.00				V
	Reverse Breakdown Voltage Tolerance (Note 6)	$I_R = 150 \mu\text{A}$		$\pm 10$	$\pm 20$	$\pm 50$	mV (max)
		Industrial Temp. Range			<b><math>\pm 43</math></b>	<b><math>\pm 53</math></b>	<b><math>\pm 83</math></b>
	Extended Temp. Range			<b><math>\pm 60</math></b>	<b><math>\pm 70</math></b>	<b><math>\pm 100</math></b>	mV (max)
$I_{RMIN}$	Minimum Operating Current		80				$\mu\text{A}$
		Industrial Temp. Range		100	100	100	$\mu\text{A}$ (max)
		Extended Temp. Range		<b>103</b>	<b>103</b>	<b>103</b>	$\mu\text{A}$ (max)
				<b>110</b>	<b>110</b>	<b>110</b>	$\mu\text{A}$ (max)
$\Delta V_R/\Delta T$	Average Reverse Breakdown Voltage Temperature Coefficient (Note 6)	$I_R = 10 \text{ mA}$	$\pm 40$				ppm/ $^\circ\text{C}$
		$I_R = 1 \text{ mA}$	$\pm 20$				ppm/ $^\circ\text{C}$
		$I_R = 150 \mu\text{A}$	$\pm 20$	<b><math>\pm 50</math></b>	<b><math>\pm 50</math></b>	<b><math>\pm 50</math></b>	ppm/ $^\circ\text{C}$ (max)
$\Delta V_R/\Delta I_R$	Reverse Breakdown Voltage Change with Operating Current Change (Note 7)	$I_{RMIN} \leq I_R \leq 1 \text{ mA}$	0.8				mV
				1.5	1.5	1.5	mV (max)
				<b>3.5</b>	<b>3.5</b>	<b>3.5</b>	mV (max)
		$1 \text{ mA} \leq I_R \leq 15 \text{ mA}$	8.0				mV
				12.0	12.0	12.0	mV (max)
				<b>23.0</b>	<b>23.0</b>	<b>23.0</b>	mV (max)
$Z_R$	Reverse Dynamic Impedance	$I_R = 1 \text{ mA}$ , $f = 120 \text{ Hz}$ , $I_{AC} = 0.1 I_R$	0.7				$\Omega$
$e_N$	Wideband Noise	$I_R = 150 \mu\text{A}$ $10 \text{ Hz} \leq f \leq 10 \text{ kHz}$	150				$\mu\text{V}_{rms}$
$\Delta V_R$	Reverse Breakdown Voltage Long Term Stability	$t = 1000 \text{ hrs}$ $T = 25^\circ\text{C} \pm 0.1^\circ\text{C}$ $I_R = 150 \mu\text{A}$	120				ppm
$V_{HYST}$	Thermal Hysteresis (Note 8)	$\Delta T = -40^\circ\text{C}$ to $125^\circ\text{C}$	2.8				mV

**Note 1:** Absolute Maximum Ratings indicate limits beyond which damage to the device may occur. Operating Ratings indicate conditions for which the device is functional, but do not guarantee specific performance limits. For guaranteed specifications and test conditions, see the Electrical Characteristics. The guaranteed specifications apply only for the test conditions listed. Some performance characteristics may degrade when the device is not operated under the listed test conditions.

**Note 2:** The maximum power dissipation must be derated at elevated temperatures and is dictated by  $T_{Jmax}$  (maximum junction temperature),  $\theta_{JA}$  (junction to ambient thermal resistance), and  $T_A$  (ambient temperature). The maximum allowable power dissipation at any temperature is  $PD_{max} = (T_{Jmax} - T_A)/\theta_{JA}$  or the number given in the Absolute Maximum Ratings, whichever is lower. For the LM4050,  $T_{Jmax} = 125^\circ\text{C}$ , and the typical thermal resistance ( $\theta_{JA}$ ), when board mounted, is  $326^\circ\text{C/W}$  for the SOT-23 package.

**Note 3:** The human body model is a  $100 \text{ pF}$  capacitor discharged through a  $1.5 \text{ k}\Omega$  resistor into each pin. The machine model is a  $200 \text{ pF}$  capacitor discharged directly into each pin.

**Note 4:** Typical values are at  $T_J = 25^\circ\text{C}$  and represent most likely parametric norm.

**Note 5:** Limits are 100% production tested at  $25^\circ\text{C}$ . Limits over temperature are guaranteed through correlation using Statistical Quality Control (SQC) methods. The limits are used to calculate National's AOQL.

**Note 6:** The boldface (over-temperature) limit for Reverse Breakdown Voltage Tolerance is defined as the room temperature Reverse Breakdown Voltage Tolerance  $\pm[(\Delta V_R/\Delta T)(\max\Delta T)(V_R)]$ . Where,  $\Delta V_R/\Delta T$  is the  $V_R$  temperature coefficient,  $\max\Delta T$  is the maximum difference in temperature from the reference point of  $25^\circ\text{C}$  to  $T_{MIN}$  or  $T_{MAX}$ , and  $V_R$  is the reverse breakdown voltage. The total over-temperature tolerance for the different grades in the industrial temperature range where  $\max\Delta T = 65^\circ\text{C}$  is shown below:

A-grade:  $\pm 0.425\% = \pm 0.1\% \pm 50 \text{ ppm}/^\circ\text{C} \times 65^\circ\text{C}$

B-grade:  $\pm 0.525\% = \pm 0.2\% \pm 50 \text{ ppm}/^\circ\text{C} \times 65^\circ\text{C}$

C-grade:  $\pm 0.825\% = \pm 0.5\% \pm 50 \text{ ppm}/^\circ\text{C} \times 65^\circ\text{C}$

Therefore, as an example, the A-grade LM4050-2.5 has an over-temperature Reverse Breakdown Voltage tolerance of  $\pm 2.5\text{V} \times 0.425\% = \pm 11 \text{ mV}$ .

**Note 7:** Load regulation is measured on pulse basis from no load to the specified load current. Output changes due to die temperature change must be taken into account separately.

**Note 8:** Thermal hysteresis is defined as the difference in voltage measured at  $+25^\circ\text{C}$  after cycling to temperature  $-40^\circ\text{C}$  and the  $25^\circ\text{C}$  measurement after cycling to temperature  $+125^\circ\text{C}$ .

# Typical Performance Characteristics

Output Impedance vs Frequency

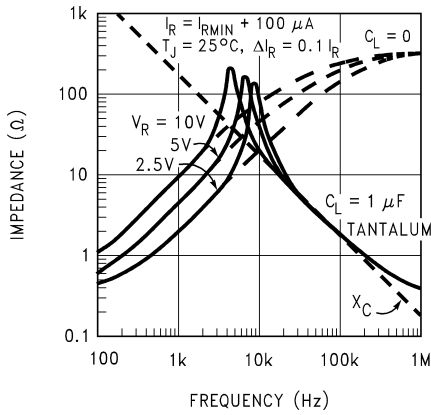

10104510

Output Impedance vs Frequency

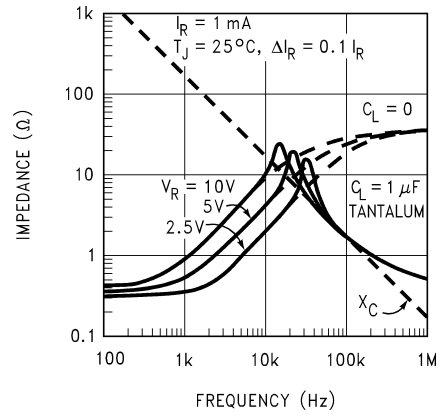

10104511

Reverse Characteristics and Minimum Operating Current

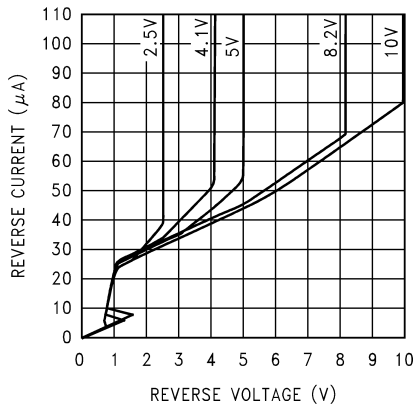

10104512

Noise Voltage vs Frequency

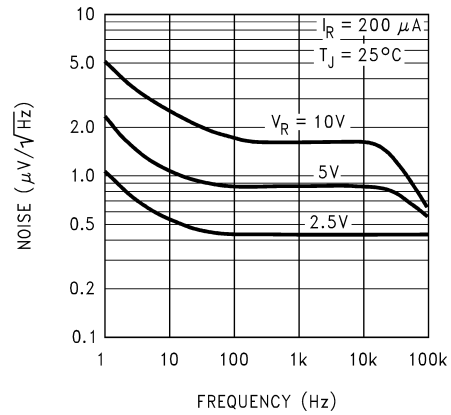

10104513

Thermal Hysteresis

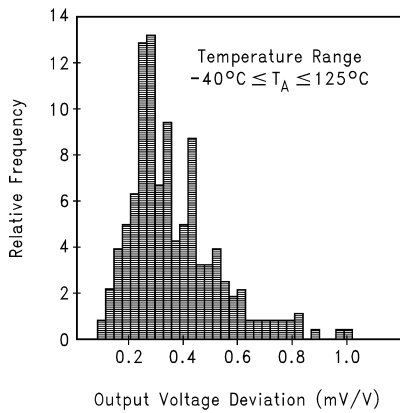

10104529

# Start-Up Characteristics

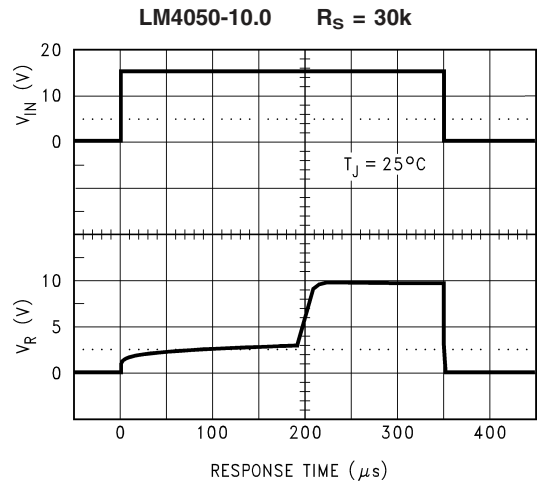
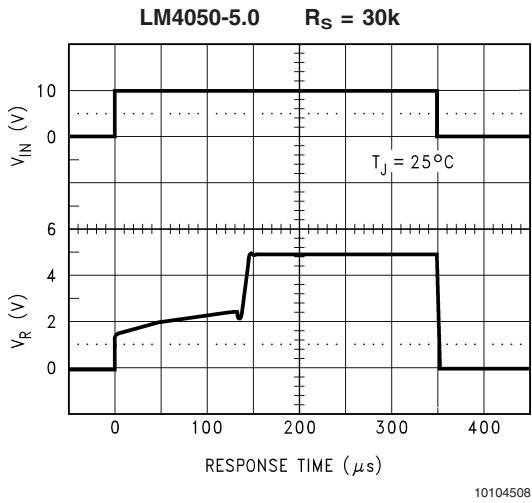
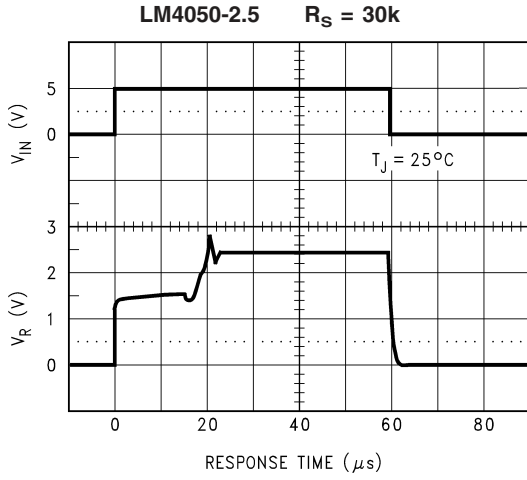
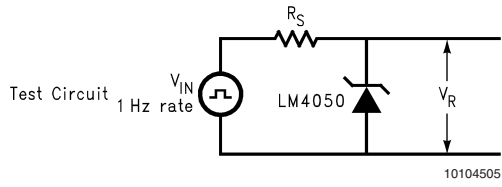

## Functional Block Diagram

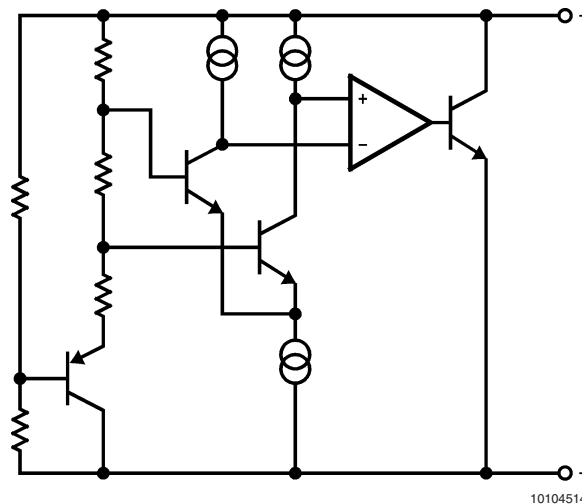

## Applications Information

The LM4050 is a precision micro-power curvature-corrected bandgap shunt voltage reference. For space critical applications, the LM4050 is available in the sub-miniature SOT-23 surface-mount package. The LM4050 has been designed for stable operation without the need of an external capacitor connected between the “+” pin and the “-” pin. If, however, a bypass capacitor is used, the LM4050 remains stable. Reducing design effort is the availability of several fixed reverse breakdown voltages: 2.048V, 2.500V, 4.096V, 5.000V, 8.192V, and 10.000V. The minimum operating current increases from 60  $\mu$ A for the LM4050-2.0 to 100  $\mu$ A for the LM4050-10.0. All versions have a maximum operating current of 15 mA.

LM4050s in the SOT-23 packages have a parasitic Schottky diode between pin 2 (-) and pin 3 (Die attach interface contact). Therefore, pin 3 of the SOT-23 package must be left floating or connected to pin 2.

The 4.096V version allows single +5V 12-bit ADCs or DACs to operate with an LSB equal to 1 mV. For 12-bit ADCs or DACs that operate on supplies of 10V or greater, the 8.192V version gives 2 mV per LSB.

The typical thermal hysteresis specification is defined as the change in +25°C voltage measured after thermal cycling. The device is thermal cycled to temperature -40°C and then measured at 25°C. Next the device is thermal cycled to

temperature +125°C and again measured at 25°C. The resulting  $V_{OUT}$  delta shift between the 25°C measurements is thermal hysteresis. Thermal hysteresis is common in precision references and is induced by thermal-mechanical package stress. Changes in environmental storage temperature, operating temperature and board mounting temperature are all factors that can contribute to thermal hysteresis.

In a conventional shunt regulator application (*Figure 1*), an external series resistor ( $R_S$ ) is connected between the supply voltage and the LM4050.  $R_S$  determines the current that flows through the load ( $I_L$ ) and the LM4050 ( $I_Q$ ). Since load current and supply voltage may vary,  $R_S$  should be small enough to supply at least the maximum guaranteed  $I_{RMIN}$  (spec. table) to the LM4050 even when the supply voltage is at its minimum and the load current is at its maximum value. When the supply voltage is at its maximum and  $I_L$  is at its minimum,  $R_S$  should be large enough so that the current flowing through the LM4050 is less than 15 mA.

$R_S$  is determined by the supply voltage, ( $V_S$ ), the load and operating current, ( $I_L$  and  $I_Q$ ), and the LM4050's reverse breakdown voltage,  $V_R$ .

$$R_S = \frac{V_S - V_R}{I_L + I_Q}$$

## Typical Applications

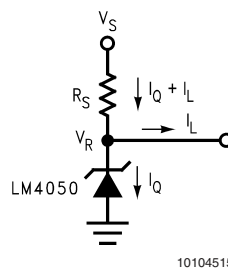
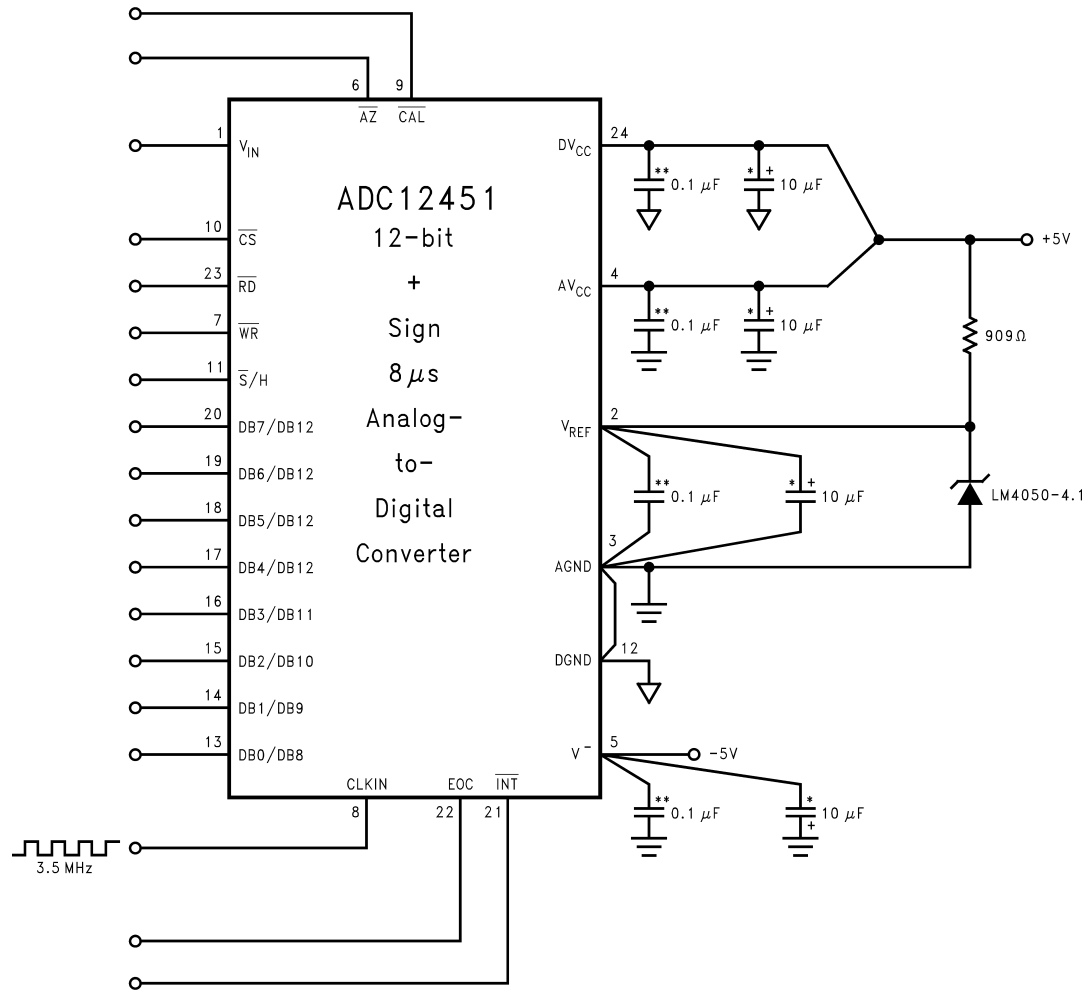

FIGURE 1. Shunt Regulator

Typical Applications (Continued)



\*\*Ceramic monolithic  
\*Tantalum

10104516

FIGURE 2. LM4050-4.1's Nominal 4.096 breakdown voltage gives ADC12451 1 mV/LSB

Typical Applications (Continued)

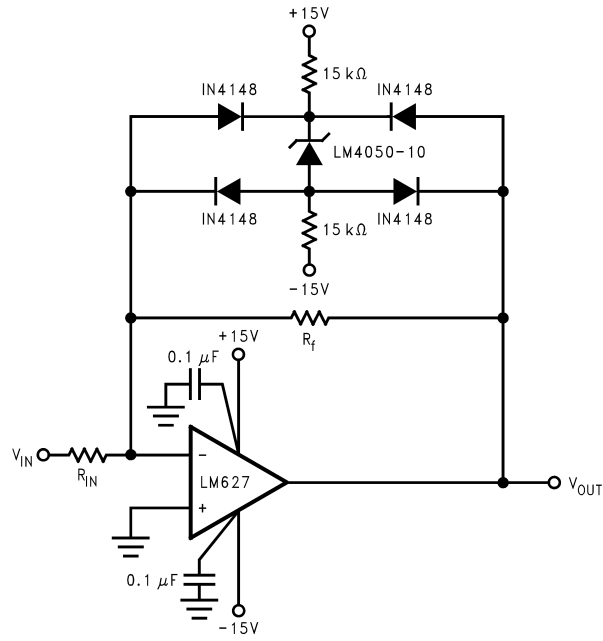

10104517

FIGURE 3. Bounded amplifier reduces saturation-induced delays and can prevent succeeding stage damage. Nominal clamping voltage is  $\pm 11.5V$  (LM4050's reverse breakdown voltage +2 diode  $V_F$ ).

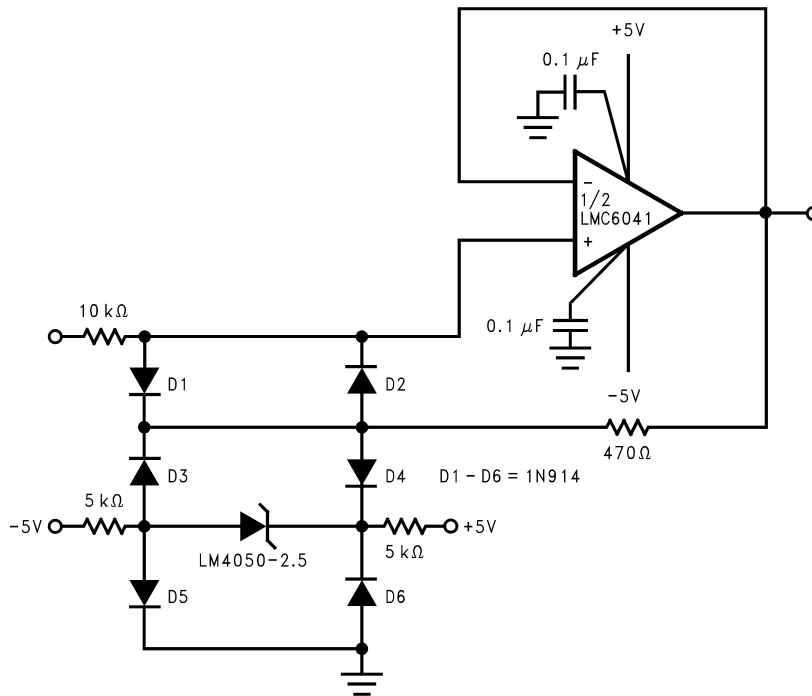

10104518

FIGURE 4. Protecting Op Amp input. The bounding voltage is  $\pm 4V$  with the LM4050-2.5 (LM4050's reverse breakdown voltage + 3 diode  $V_F$ ).

Typical Applications (Continued)

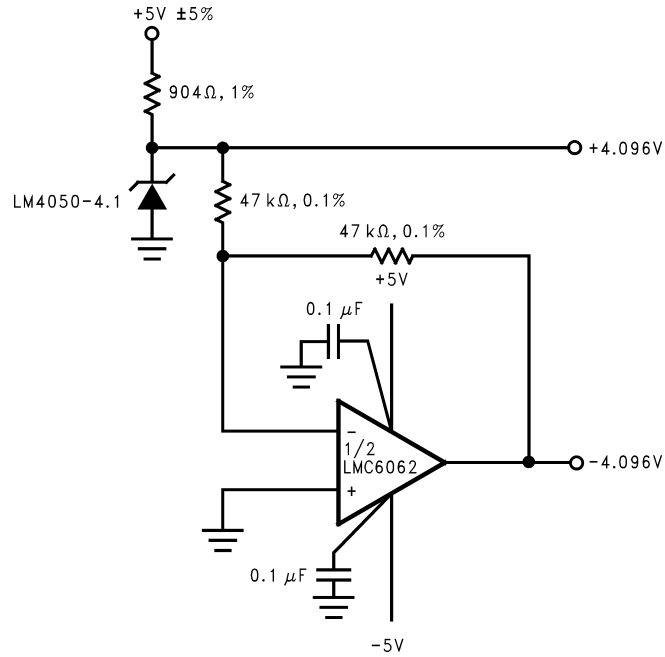

10104519

FIGURE 5. Precision ±4.096V Reference

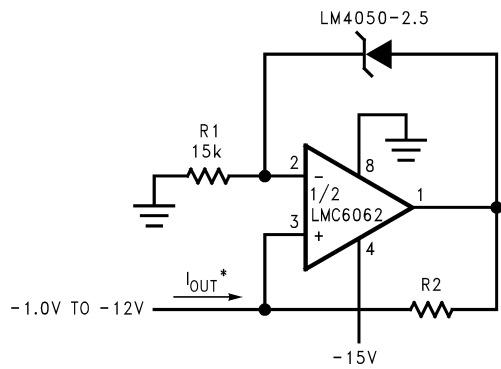

10104521

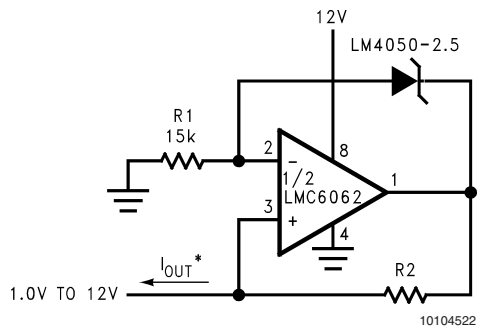

10104522

$$*I_{OUT} = \frac{2.5V}{R_2}$$

FIGURE 6. Precision 1 µA to 1 mA Current Sources

**Physical Dimensions** inches (millimeters) unless otherwise noted

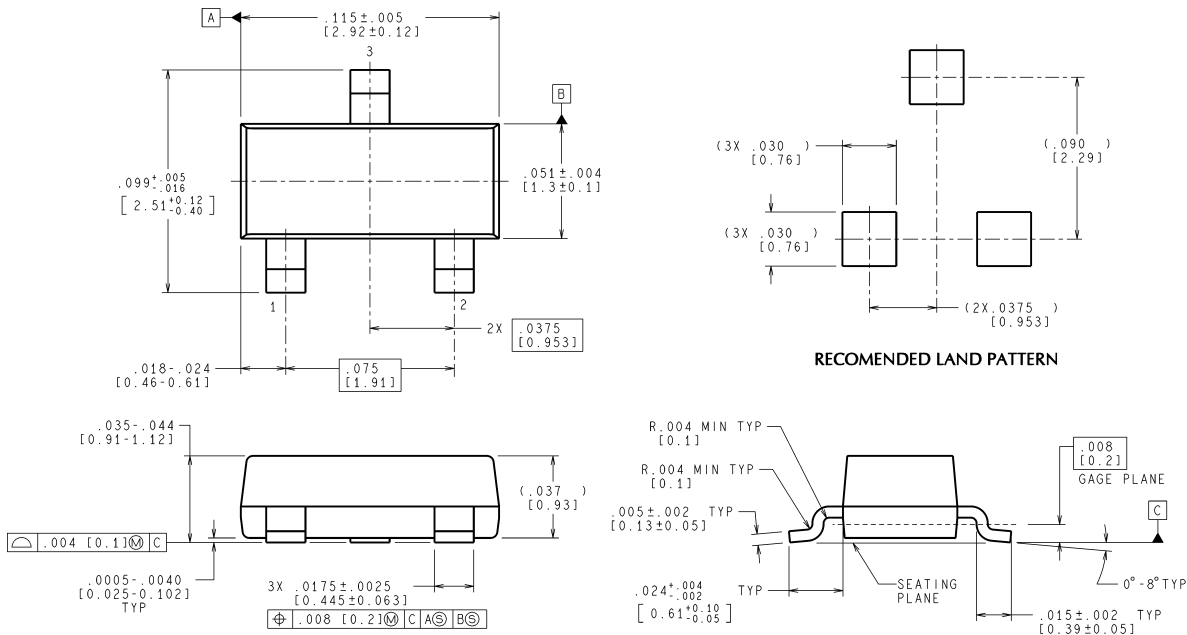

CONTROLLING DIMENSION IS INCH  
VALUES IN [ ] ARE MILLIMETERS

MF03A (Rev B)

**Plastic Surface Mount Package (M3)  
NS Package Number MF03A  
(JEDEC Registration TO-236AB)**

**LIFE SUPPORT POLICY**

NATIONAL'S PRODUCTS ARE NOT AUTHORIZED FOR USE AS CRITICAL COMPONENTS IN LIFE SUPPORT DEVICES OR SYSTEMS WITHOUT THE EXPRESS WRITTEN APPROVAL OF THE PRESIDENT AND GENERAL COUNSEL OF NATIONAL SEMICONDUCTOR CORPORATION. As used herein:

1. Life support devices or systems are devices or systems which, (a) are intended for surgical implant into the body, or (b) support or sustain life, and whose failure to perform when properly used in accordance with instructions for use provided in the labeling, can be reasonably expected to result in a significant injury to the user.
2. A critical component is any component of a life support device or system whose failure to perform can be reasonably expected to cause the failure of the life support device or system, or to affect its safety or effectiveness.

**BANNED SUBSTANCE COMPLIANCE**

National Semiconductor certifies that the products and packing materials meet the provisions of the Customer Products Stewardship Specification (CSP-9-111C2) and the Banned Substances and Materials of Interest Specification (CSP-9-111S2) and contain no "Banned Substances" as defined in CSP-9-111S2.



**National Semiconductor**  
Americas Customer  
Support Center  
Email: new.feedback@nsc.com  
Tel: 1-800-272-9959

**National Semiconductor**  
Europe Customer Support Center  
Fax: +49 (0) 180-530 85 86  
Email: europe.support@nsc.com  
Deutsch Tel: +49 (0) 69 9508 6208  
English Tel: +44 (0) 870 24 0 2171  
Français Tel: +33 (0) 1 41 91 8790

**National Semiconductor**  
Asia Pacific Customer  
Support Center  
Email: ap.support@nsc.com

**National Semiconductor**  
Japan Customer Support Center  
Fax: 81-3-5639-7507  
Email: jpn.feedback@nsc.com  
Tel: 81-3-5639-7560

www.national.com