

LM4431 Micropower Shunt Voltage Reference

General Description

Ideal for space critical applications, the LM4431 voltage reference is available in the sub-miniature (3 mm x 1.3 mm) SOT-23 surface-mount package. The LM4431's advanced design eliminates the need for an external stabilizing capacitor while ensuring stability with any capacitive load, thus making the LM4431 easy to use. The operating current range is 100 μ A to 15 mA.

The LM4431 utilizes fuse and zener-zap reverse breakdown voltage trim during wafer sort to ensure that the parts have an accuracy of better than $\pm 2.0\%$ at 25°C. Bandgap reference temperature drift curvature correction and low dynamic impedance ensure stable reverse breakdown voltage accuracy over a wide range of operating temperatures and currents.

Features

- Small package: SOT-23
- No output capacitor required
- Tolerates capacitive loads
- Fixed reverse breakdown voltage of 2.50V

Key Specifications

- Output voltage tolerance 25°C $\pm 2.0\%$ (max)
- Low output noise (10 Hz to 10 kHz) 35 μ V_{rms} (typ)
- Wide operating current range 100 μ A to 15 mA
- Commercial temperature range 0°C to +70°C
- Low temperature coefficient 30 ppm/°C (typ)

Applications

- Portable, Battery-Powered Equipment
- Data Acquisition Systems
- Instrumentation
- Process Control
- Energy Management
- Product Testing
- Power Supplies

Connection Diagram

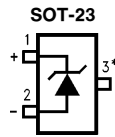

TL/H/11374-1

*This pin must be left floating or connected to pin 2.

Top View

Order Number LM4431M3-2.5
See NS Package Number M03B
(JEDEC Registration TO-236AB)

SOT-23 Package Marking Information

Only three fields of marking are possible on the SOT-23's small surface. The following table gives the meaning of the three fields.

Part Marking	Field Definition
S2E	First Field: S = Reference Second Field: 2 = 2.500V Voltage Option Third Field: E = Initial Reverse Breakdown Voltage Tolerance of $\pm 2.0\%$

Absolute Maximum Ratings (Note 1)

If Military/Aerospace specified devices are required, please contact the National Semiconductor Sales Office/Distributors for availability and specifications.

Reverse Current	20 mA
Forward Current	10 mA
Power Dissipation ($T_A = 25^\circ\text{C}$) (Note 2)	
M3 Package	306 mW
Storage Temperature	-65°C to $+150^\circ\text{C}$
Lead Temperature	
M3 Package	
Vapor phase (60 seconds)	$+215^\circ\text{C}$
Infrared (15 seconds)	$+220^\circ\text{C}$

ESD Susceptibility

Human Body Model (Note 3)	2 kV
Machine Model (Note 3)	200V

See AN-450 "Surface Mounting Methods and Their Effect on Product Reliability" for other methods of soldering surface mount devices.

Operating Ratings (Notes 1 & 2)

Temperature Range	
($T_{\min} \leq T_A \leq T_{\max}$)	$0^\circ\text{C} \leq T_A \leq +70^\circ\text{C}$
Reverse Current	
LM4431-2.5	100 μA to 15 mA

LM4431-2.5

Electrical Characteristics

Boldface limits apply for $T_A = T_J = T_{\min}$ to T_{\max} ; all other limits $T_A = T_J = 25^\circ\text{C}$.

Symbol	Parameter	Conditions	Typical (Note 4)	LM4431M3 Limits (Note 5)	Units (Limit)
V_R	Reverse Breakdown Voltage	$I_R = 100 \mu\text{A}$	2.500		V
	Reverse Breakdown Voltage Tolerance	$I_R = 100 \mu\text{A}$		± 50	mV (max)
$I_{R\min}$	Minimum Operating Current		45	100	μA μA (max)
$\Delta V_R/\Delta T$	Average Reverse Breakdown Voltage Temperature Coefficient	$I_R = 10 \text{ mA}$ $I_R = 1 \text{ mA}$ $I_R = 100 \mu\text{A}$	± 30 ± 30 ± 30		ppm/ $^\circ\text{C}$ ppm/ $^\circ\text{C}$ ppm/ $^\circ\text{C}$
$\Delta V_R/\Delta I_R$	Reverse Breakdown Voltage Change with Operating Current Change	$I_{R\min} \leq I_R \leq 1 \text{ mA}$	0.4	1.0 1.2	mV mV (max) mV (max)
		$1 \text{ mA} \leq I_R \leq 15 \text{ mA}$	2.5	8.0 25	mV mV (max) mV (max)
Z_R	Reverse Dynamic Impedance	$I_R = 1 \text{ mA}$, $f = 120 \text{ Hz}$ $I_{AC} = 0.1 I_R$	1.0		Ω
e_N	Wideband Noise	$I_R = 100 \mu\text{A}$ $10 \text{ Hz} \leq f \leq 10 \text{ kHz}$	35		μV_{rms}
ΔV_R	Reverse Breakdown Voltage Long Term Stability	$t = 1000 \text{ hrs}$ $T = 25^\circ\text{C} \pm 0.1^\circ\text{C}$ $I_R = 100 \mu\text{A}$	120		ppm

Note 1: Absolute Maximum Ratings indicate limits beyond which damage to the device may occur. Operating Ratings indicate conditions for which the device is functional, but do not guarantee specific performance limits. For guaranteed specifications and test conditions, see the Electrical Characteristics. The guaranteed specifications apply only for the test conditions listed. Some performance characteristics may degrade when the device is not operated under the listed test conditions.

Note 2: The maximum power dissipation must be derated at elevated temperatures and is dictated by $T_{J\max}$ (maximum junction temperature), θ_{JA} (junction to ambient thermal resistance), and T_A (ambient temperature). The maximum allowable power dissipation at any temperature is $PD_{\max} = (T_{J\max} - T_A)/\theta_{JA}$ or the number given in the Absolute Maximum Ratings, whichever is lower. For the LM4431, $T_{J\max} = 125^\circ\text{C}$, and the typical thermal resistance (θ_{JA}), when board mounted, is $326^\circ\text{C}/\text{W}$ for the SOT-23 package.

Note 3: The human body model is a 100 pF capacitor discharged through a 1.5 k Ω resistor into each pin. The machine model is a 200 pF capacitor discharged directly into each pin.

Note 4: Typicals are at $T_J = 25^\circ\text{C}$ and represent most likely parametric norm.

Note 5: Limits are 100% production tested at 25°C . Limits over temperature are guaranteed through correlation using Statistical Quality Control (SQC) methods. The limits are used to calculate National's AOQL.

Typical Performance Characteristics

Temperature Drift for Different Average Temperature Coefficient

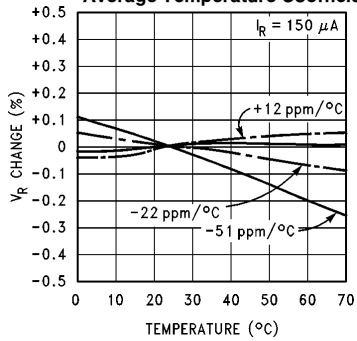

TL/H/11374-2

Output Impedance vs Frequency

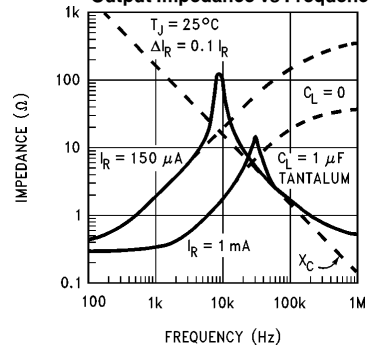

TL/H/11374-3

Reverse Characteristics and Minimum Operating Current

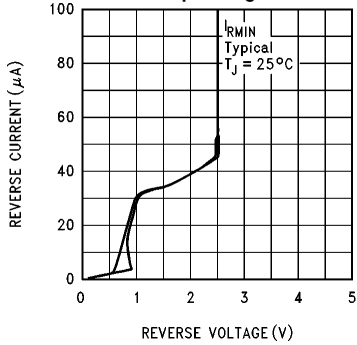

TL/H/11374-4

Noise Voltage

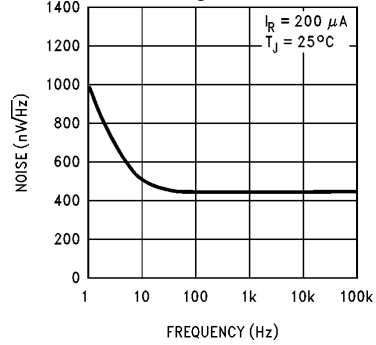

TL/H/11374-5

Start-Up Characteristics

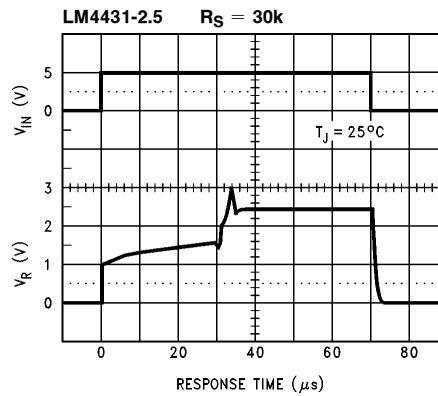
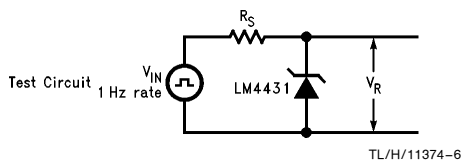

TL/H/11374-7

Functional Block Diagram

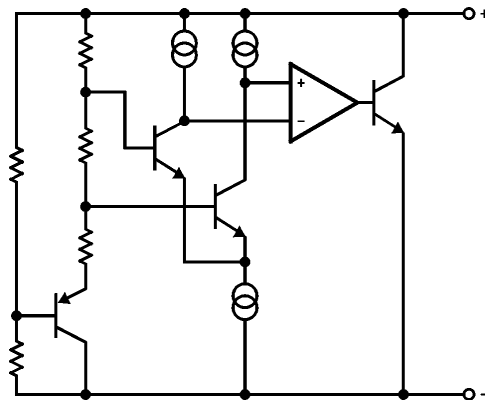

TL/H/11374-8

Applications Information

The LM4431 is a micro-power curvature-corrected 2.5V bandgap shunt voltage reference. For space critical applications, the LM4431 is available in the sub-miniature SOT-23 surface-mount package. The LM4431 has been designed for stable operation without the need of an external capacitor connected between the “+” pin and the “-” pin. If, however, a bypass capacitor is used, the LM4431 remains stable. The operating current range is 100 μ A to 15 mA.

The LM4431's SOT-23 package has a parasitic Schottky diode between pin 3 (-) and pin 1 (Die attach interface contact). Therefore, pin 1 of the SOT-23 package must be left floating or connected to pin 3.

In a conventional shunt regulator application (*Figure 1*), an external series resistor (R_S) is connected between the supply voltage and the LM4431. R_S determines the current that flows through the load (I_L) and the LM4431 (I_Q). Since load current and supply voltage may vary, R_S should be small enough to supply at least the minimum acceptable I_Q to the LM4431 even when the supply voltage is at its minimum and the load current is at its maximum value. When the supply voltage is at its maximum and I_L is at its minimum, R_S

should be large enough so that the current flowing through the LM4431 is less than 15 mA.

R_S is determined by the supply voltage, (V_S), the load and operating current, (I_L and I_Q), and the LM4431's reverse breakdown voltage, V_R .

$$R_S = \frac{V_S - V_R}{I_L + I_Q}$$

Typical Applications

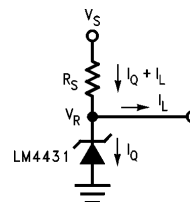

TL/H/11374-9

FIGURE 1. Shunt Regulator

Typical Applications (Continued)

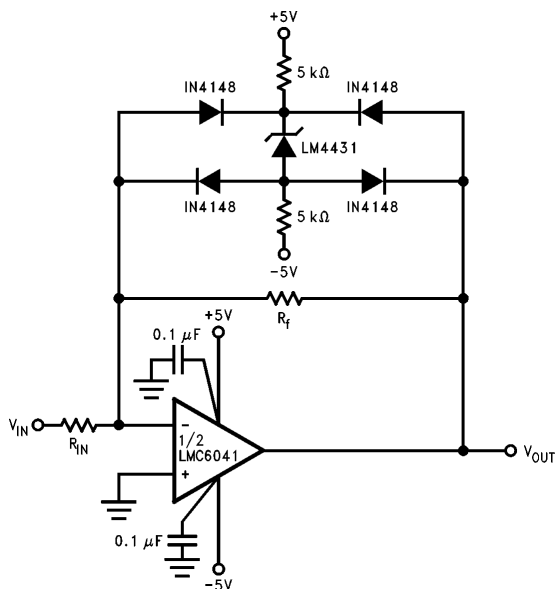

TL/H/11374-10

FIGURE 2. Bounded amplifier reduces saturation-induced delays and can prevent succeeding stage damage. Nominal clamping voltage is ±3.9V (LM4431's reverse breakdown voltage + 2 diode V_F).

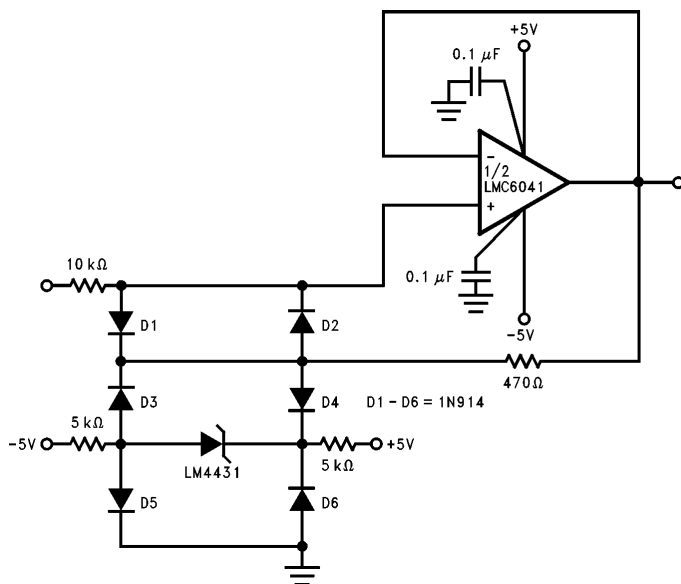

TL/H/11374-11

FIGURE 3. Protecting Op Amp input. The bounding voltage is ±4V with the LM4431 (LM4431's reverse breakdown voltage + 3 diode V_F).

Typical Applications (Continued)

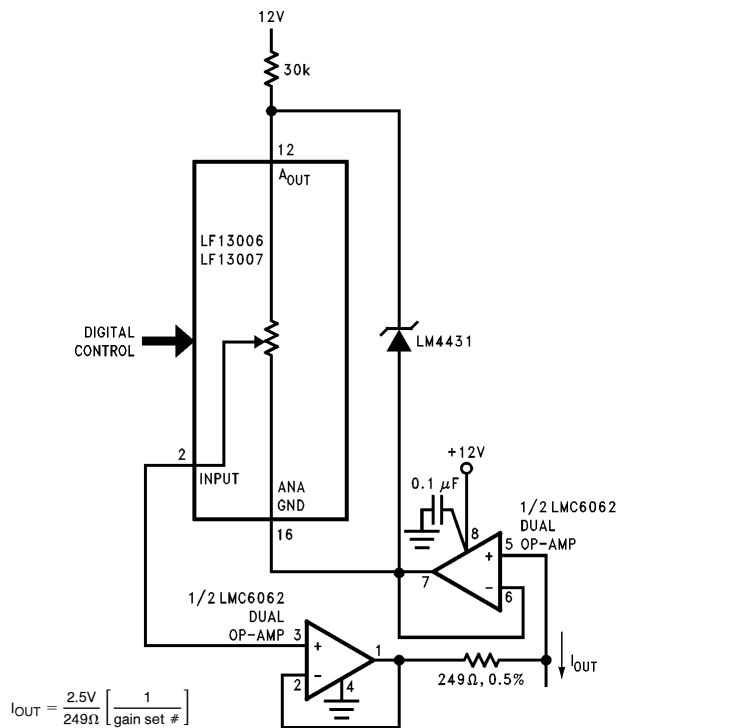

FIGURE 4. Programmable Current Source

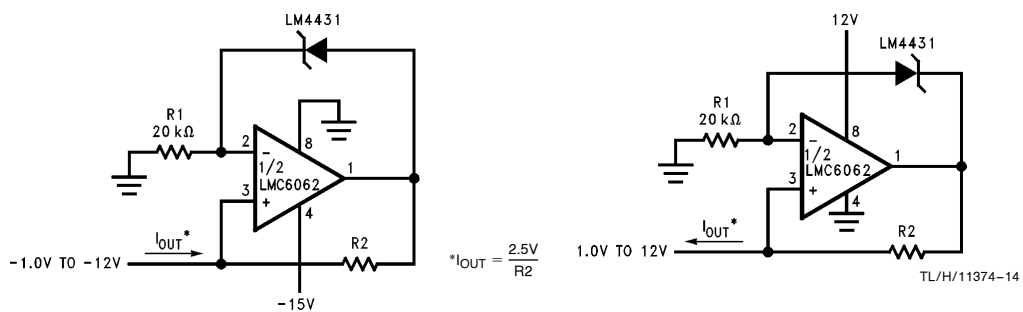
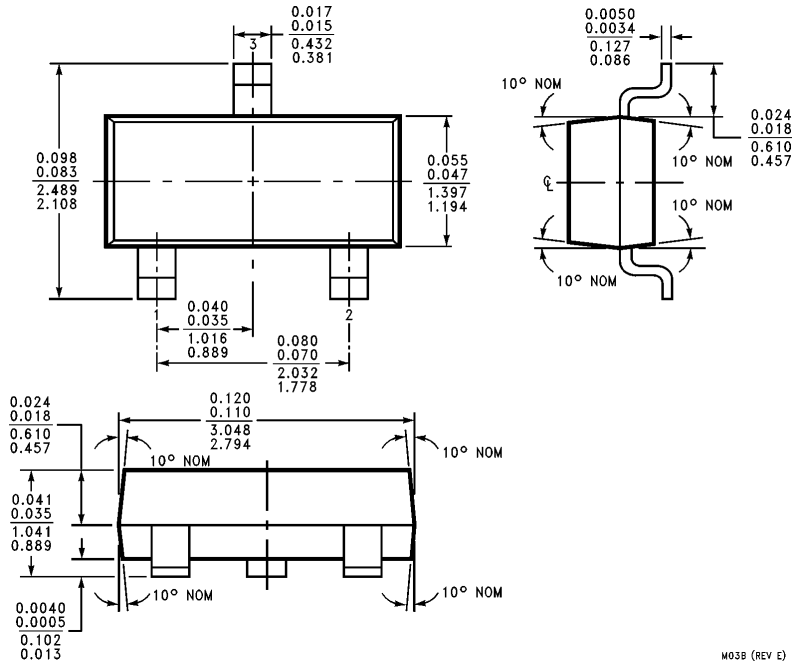

FIGURE 5. Precision 1 μA to 1 mA Current Sources

Physical Dimensions inches (millimeters)



**Plastic Surface Mount Package (M3)
NS Package Number M03B
(JEDEC Registration TO-236AB)**

LIFE SUPPORT POLICY

NATIONAL'S PRODUCTS ARE NOT AUTHORIZED FOR USE AS CRITICAL COMPONENTS IN LIFE SUPPORT DEVICES OR SYSTEMS WITHOUT THE EXPRESS WRITTEN APPROVAL OF THE PRESIDENT OF NATIONAL SEMICONDUCTOR CORPORATION. As used herein:

1. Life support devices or systems are devices or systems which, (a) are intended for surgical implant into the body, or (b) support or sustain life, and whose failure to perform, when properly used in accordance with instructions for use provided in the labeling, can be reasonably expected to result in a significant injury to the user.
2. A critical component is any component of a life support device or system whose failure to perform can be reasonably expected to cause the failure of the life support device or system, or to affect its safety or effectiveness.



National Semiconductor Corporation
1111 West Bardin Road
Arlington, TX 76017
Tel: 1(800) 272-9959
Fax: 1(800) 737-7018

National Semiconductor Europe
Fax: (+49) 0-180-530 85 86
Email: cnjwge@tevm2.nsc.com
Deutsch Tel: (+49) 0-180-530 85 85
English Tel: (+49) 0-180-532 78 32
Français Tel: (+49) 0-180-532 93 58
Italiano Tel: (+49) 0-180-534 16 80

National Semiconductor Hong Kong Ltd.
19th Floor, Straight Block,
Ocean Centre, 5 Canton Rd.
Tsimshatsui, Kowloon
Hong Kong
Tel: (852) 2737-1600
Fax: (852) 2736-9960

National Semiconductor Japan Ltd.
Tel: 81-043-299-2309
Fax: 81-043-299-2408

National does not assume any responsibility for use of any circuitry described, no circuit patent licenses are implied and National reserves the right at any time without notice to change said circuitry and specifications.