

## LM6125/LM6225/LM6325 High Speed Buffer

### General Description

The LM6125 family of high speed unity gain buffers slew at 800 V/ $\mu$ s and have a small signal bandwidth of 50 MHz while driving a 50 $\Omega$  load. These buffers drive  $\pm 300$  mA peak and do not oscillate while driving large capacitive loads. The LM6125 contains unique features not found in power buffers; these include current limit, thermal shutdown, electronic shutdown, and an error flag that warns of fault conditions.

These buffers are built with National's VIP™ (Vertically Integrated PNP) process which provides fast PNP transistors that are true complements to the already fast NPN devices. This advanced junction-isolated process delivers high speed performance without the need for complex and expensive dielectric isolation.

### Features

- High slew rate
- High output current
- Stable with large capacitive loads
- Current and thermal limiting
- Electronic shutdown
- 5V to  $\pm 15$ V operation guaranteed
- Fully specified to drive 50 $\Omega$  lines

800 V/ $\mu$ s  
 $\pm 300$  mA

### Applications

- Line Driving
- Radar
- Sonar

### Simplified Schematic and Block Diagram

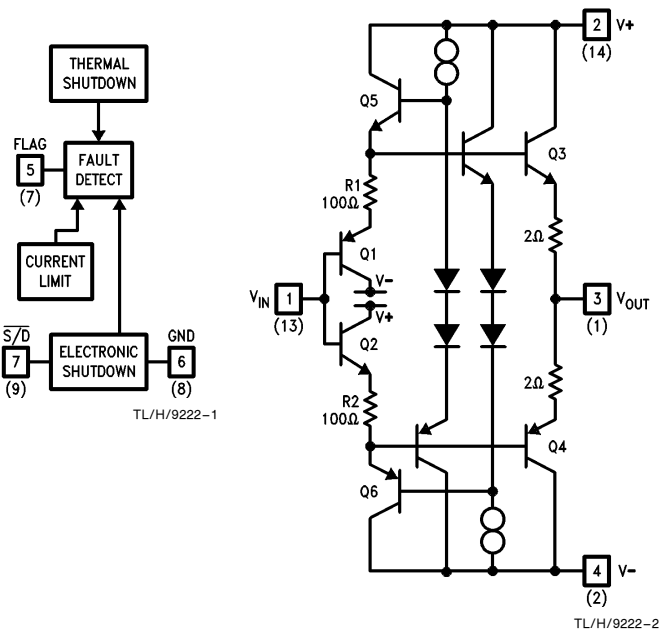

Numbers in ( ) are for 14-pin N DIP.

### Pin Configurations

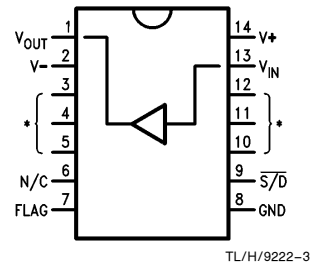

\*Heat sinking pins.  
Internally connected to V-.

**Order Number LM6225N  
or LM6325N**  
See NS Package Number N14A

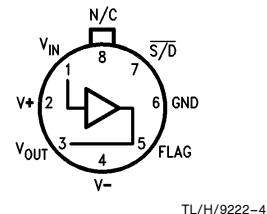

#### Top View

Note: Pin 4 connected to case

**Order Number LM6125H/883\*  
or LM6125H**  
See NS Package Number H08C

\*Available per 5962-9081501

VIP™ is a trademark of National Semiconductor Corporation.

## Absolute Maximum Ratings (Note 1)

If Military/Aerospace specified devices are required, please contact the National Semiconductor Sales Office/Distributors for availability and specifications.

Supply Voltage	36V ( $\pm 18V$ )
Input to Output Voltage (Note 2)	$\pm 7V$
Input Voltage	$\pm V_{supply}$
Output Short-Circuit to GND (Note 3)	Continuous
Flag Output Voltage	$GND \leq V_{flag} \leq +V_{supply}$
Storage Temperature Range	$-65^{\circ}C$ to $+150^{\circ}C$
Lead Temperature (Soldering, 10 seconds)	$260^{\circ}C$

ESD Tolerance (Note 9)	$\pm 1500V$
$\theta_{JA}$ (Note 4)	
H Package	$150^{\circ}C/W$
N Package	$40^{\circ}C/W$
Maximum Junction Temperature ( $T_J$ )	$150^{\circ}C$
Operating Temperature Range	
LM6125	$-55^{\circ}C$ to $+125^{\circ}C$
LM6225	$-40^{\circ}C$ to $+85^{\circ}C$
LM6325	$0^{\circ}C$ to $+70^{\circ}C$
Operating Supply Voltage Range	$4.75V$ to $\pm 16V$

## DC Electrical Characteristics

The following specifications apply for Supply Voltage =  $\pm 15V$ ,  $V_{CM} = 0$ ,  $R_L \geq 100 k\Omega$  and  $R_S = 50\Omega$  unless otherwise noted. **Boldface** limits apply for  $T_A = T_J = T_{MIN}$  to  $T_{MAX}$ ; all other limits  $T_A = T_J = 25^{\circ}C$ .

Symbol	Parameter	Conditions	Typ	LM6125	LM6225	LM6325	Units
				Limit (Notes 5, 10)	Limit (Note 5)	Limit (Note 5)	
$A_{V1}$	Voltage Gain 1	$R_L = 1k\Omega$ , $V_{IN} = \pm 10V$	0.990	0.980 <b>0.970</b>	0.980 <b>0.950</b>	0.970 <b>0.950</b>	V/V Min
$A_{V2}$	Voltage Gain 2	$R_L = 50\Omega$ , $V_{IN} = \pm 10V$	0.900	0.860 <b>0.800</b>	0.860 <b>0.820</b>	0.850 <b>0.820</b>	
$A_{V3}$	Voltage Gain 3 (Note 6)	$R_L = 50\Omega$ , $V^+ = 5V$ $V_{IN} = 2 V_{PP}$ ( <b>1.5 V<sub>PP</sub></b> )	0.840	0.780 <b>0.750</b>	0.780 <b>0.700</b>	0.750 <b>0.700</b>	
$V_{OS}$	Offset Voltage	$R_L = 1k\Omega$	15	30 <b>50</b>	30 <b>60</b>	50 <b>100</b>	mV Max
$I_B$	Input Bias Current	$R_L = 1k\Omega$ , $R_S = 10k\Omega$	1	4 <b>7</b>	4 <b>7</b>	5 <b>7</b>	$\mu A$ Max
$R_{IN}$	Input Resistance	$R_L = 50\Omega$	5				M $\Omega$
$C_{IN}$	Input Capacitance		3.5				pF
$R_O$	Output Resistance	$I_{OUT} = \pm 10mA$	3	5 <b>10</b>	5 <b>10</b>	5 <b>6</b>	$\Omega$ Max
$I_{S1}$	Supply Current 1	$R_L = \infty$	15	18 <b>20</b>	18 <b>20</b>	20 <b>22</b>	mA Max
$I_{S2}$	Supply Current 2	$R_L = \infty$ , $V^+ = 5V$	14	16 <b>18</b>	16 <b>18</b>	18 <b>20</b>	
$I_{S/D}$	Supply Current in Shutdown	$R_L = \infty$ , $V^{\pm} = \pm 15V$	1.1	1.5 <b>2.0</b>	1.5 <b>2.0</b>	1.5 <b>2.0</b>	
$V_{O1}$	Output Swing 1	$R_L = 1k\Omega$	13.5	13.3 <b>13</b>	13.3 <b>13</b>	13.2 <b>13</b>	$\pm V$ Min
$V_{O2}$	Output Swing 2	$R_L = 100\Omega$	12.7	11.5 <b>10</b>	11.5 <b>10</b>	11 <b>10</b>	
$V_{O3}$	Output Swing 3	$R_L = 50\Omega$	12	11 <b>9</b>	11 <b>9</b>	10 <b>9</b>	
$V_{O4}$	Output Swing 4	$R_L = 50\Omega$	1.8	1.6 <b>1.3</b>	1.6 <b>1.4</b>	1.6 <b>1.5</b>	$V_{PP}$ Min
PSRR	Power Supply Rejection Ratio	$V^+ = 5V$ (Note 6)	70	60 <b>55</b>	60 <b>50</b>	60 <b>50</b>	dB Min
$V_{OL}$	Flag Pin Output Low Voltage	$V^{\pm} = \pm 5V$ to $\pm 15V$ $V_{S/D} = 0V$		300 <b>400</b>	300 <b>400</b>	340 <b>400</b>	mV Max
$I_{OH}$	Flag Pin Output High Current	$V_{OH}$ Flag Pin = $15V$ (Note 7)	0.01	10 <b>20</b>	10 <b>20</b>	10 <b>20</b>	$\mu A$ Max

## DC Electrical Characteristics (Continued)

The following specifications apply for Supply Voltage =  $\pm 15V$ ,  $V_{CM} = 0$ ,  $R_L \geq 100\text{ k}\Omega$  and  $R_S = 50\Omega$  unless otherwise noted.

**Boldface** limits apply for  $T_A = T_J = T_{MIN}$  to  $T_{MAX}$ ; all other limits  $T_A = T_J = 25^\circ\text{C}$ .

Symbol	Parameter	Conditions	Typ	LM6125	LM6225	LM6325	Units
				Limit (Notes 5, 10)	Limit (Note 5)	Limit (Note 5)	
$V_{TH}$	Shutdown Threshold		1.4				V
$V_{IH}$	Shutdown Pin Trip Point High			2.0 <b>2.0</b>	2.0 <b>2.0</b>	2.0 <b>2.0</b>	V Min
$V_{IL}$	Shutdown Pin Trip Point Low			0.8 <b>0.8</b>	0.8 <b>0.8</b>	0.8 <b>0.8</b>	V Max
$I_{IL}$	Shutdown Pin Input Low Current	$V_{S/D} = 0V$	-0.07	-10 <b>-20</b>	-10 <b>-20</b>	-10 <b>-20</b>	$\mu\text{A}$ Max
$I_{IH}$	Shutdown Pin Input High Current	$V_{S/D} = 5V$	-0.05	-10 <b>-20</b>	-10 <b>-20</b>	-10 <b>-20</b>	$\mu\text{A}$ Max
$I_O$	Bi-State Output Current	Shutdown Pin = 0V $V_{OUT} = +5V$ or $-5V$	1	50 <b>2000</b>	50 <b>100</b>	100 <b>200</b>	$\mu\text{A}$

## AC Electrical Characteristics

The following specifications apply for Supply Voltage =  $\pm 15V$ ,  $V_{CM} = 0$ ,  $R_L \geq 100\text{ k}\Omega$  and  $R_S = 50\Omega$  unless otherwise noted.

**Boldface** limits apply for  $T_A = T_J = T_{MIN}$  to  $T_{MAX}$ ; all other limits  $T_A = T_J = 25^\circ\text{C}$ .

Symbol	Parameter	Conditions	Typ	LM6125	LM6225	LM6325	Units
				Limit (Note 5)	Limit (Note 5)	Limit (Note 5)	
$SR_1$	Slew Rate 1	$V_{IN} = \pm 11V$ , $R_L = 1\text{ k}\Omega$	1200				V/ $\mu\text{s}$ Min
$SR_2$	Slew Rate 2	$V_{IN} = \pm 11V$ , $R_L = 50\Omega$ (Note 8)	800	550	550	550	
$SR_3$	Slew Rate 3	$V_{IN} = 2 V_{PP}$ , $R_L = 50\Omega$ $V^T = 5V$ (Note 6)	50				
BW	-3 dB Bandwidth	$V_{IN} = 100\text{ mV}_{PP}$ $R_L = 50\Omega$ , $C_L \leq 10\text{ pF}$	50	30	30	30	MHz Min
$t_r, t_f$	Rise Time Fall Time	$R_L = 50\Omega$ , $C_L \leq 10\text{ pF}$ $V_O = 100\text{ mV}_{PP}$	8.0				ns
$t_{pD}$	Propagation Delay Time	$R_L = 50\Omega$ , $C_L \leq 10\text{ pF}$ $V_O = 100\text{ mV}_{PP}$	4.0				ns
$O_S$	Overshoot	$R_L = 50\Omega$ , $C_L \leq 10\text{ pF}$ $V_O = 100\text{ mV}_{PP}$	10				%
$V_{FT}$	$V_{IN}, V_{OUT}$ Feedthrough in Shutdown	Shutdown Pin = 0V $V_{IN} = 4 V_{PP}$ , 1 MHz $R_L = 50\Omega$	-50				dB
$C_{OUT}$	Output Capacitance in Shutdown	Shutdown Pin = 0V	30				pF
$t_{SD}$	Shutdown Response Time		700				ns

## Electrical Characteristics (Continued)

**Note 1:** Absolute Maximum Ratings indicate limits beyond which damage to the device may occur. DC and AC electrical specifications do not apply when operating the device beyond its rated operating conditions.

**Note 2:** During current limit, thermal limit, or electronic shutdown the input current will increase if the input to output differential voltage exceeds 8V. See Overvoltage Protection in Application Hints.

**Note 3:** The LM6125 series buffers contain current limit and thermal shutdown to protect against fault conditions.

**Note 4:** For operation at elevated temperature, these devices must be derated based on a thermal resistance of  $\theta_{JA}$  and  $T_J$  max,  $T_J = T_A + \theta_{JA} P_D$ .  $\theta_{JC}$  for the LM6125H and LM6225H is 17°C/W. The thermal impedance  $\theta_{JA}$  of the device in the N package is 40°C/W when soldered directly to a printed circuit board, and the heat-sinking pins (pins 3, 4, 5, 10, 11, and 12) are connected to 2 square inches of 2 oz. copper. When installed in a socket, the thermal impedance  $\theta_{JA}$  of the N package is 60°C/W.

**Note 5:** Limits are guaranteed by testing or correlation.

**Note 6:** The input is biased to +2.5V, and  $V_{IN}$  swings  $V_{PP}$  about this value. The input swing is 2  $V_{PP}$  at all temperatures except for the  $A_V3$  test at -55°C where it is reduced to 1.5  $V_{PP}$ .

**Note 7:** The Error Flag is set (low) during current limit or thermal fault detection in addition to being set by the Shutdown pin. It is an open-collector output which requires an external pullup resistor.

**Note 8:** Slew rate is measured with a  $\pm 11V$  input pulse and 50 $\Omega$  source impedance at 25°C. Since voltage gain is typically 0.9 driving a 50 $\Omega$  load, the output swing will be approximately  $\pm 10V$ . Slew rate is calculated for transitions between  $\pm 5V$  levels on both rising and falling edges. A high speed measurement is done to minimize device heating. For slew rate versus junction temperature see typical performance curves. The input pulse amplitude should be reduced to  $\pm 10V$  for measurements at temperature extremes. For accurate measurements, the input slew rate should be at least 1700 V/ $\mu$ s.

**Note 9:** The test circuit consists of the human body model of 120 pF in series with 1500 $\Omega$ .

**Note 10:** A military RETS specification is available on request. At the time of printing, the LM6125H/883 RETS spec complied with the **Boldface** limits in this column. The LM6125H/883 may also be procured as Standard Military Drawing specification #5962-9081501MXX.

## Typical Performance Characteristics $T_A = 25^\circ\text{C}$ , $V_S = \pm 15V$ , unless otherwise specified

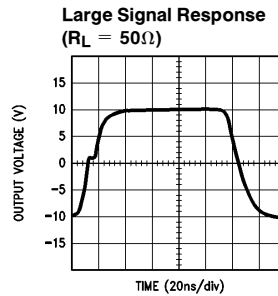
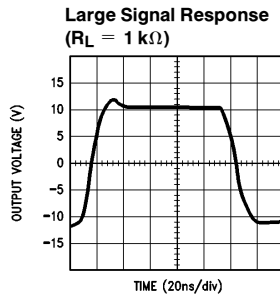
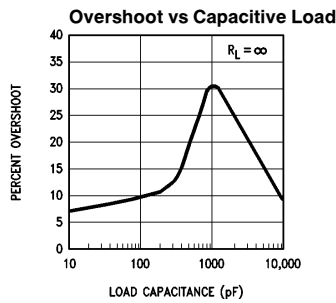
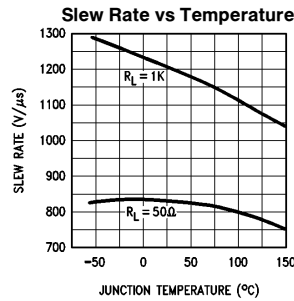
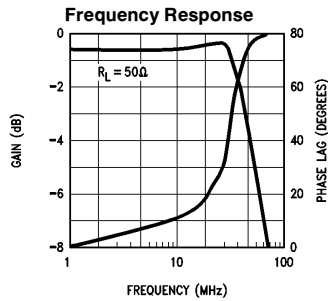
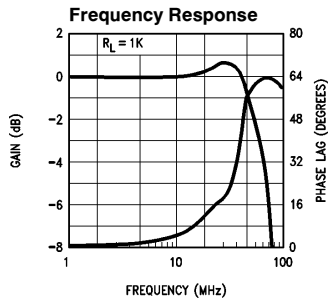

TL/H/9222-5

**Typical Performance Characteristics**  $T_A = 25^\circ\text{C}$ ,  $V_S = \pm 15\text{V}$ , unless otherwise specified (Continued)

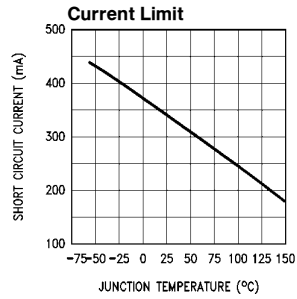
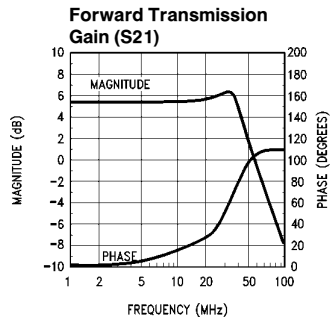
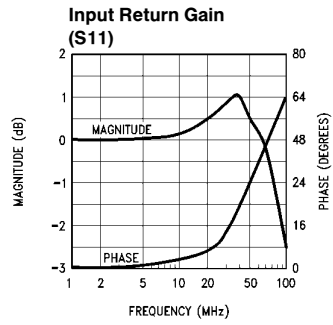
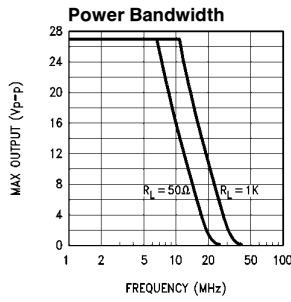
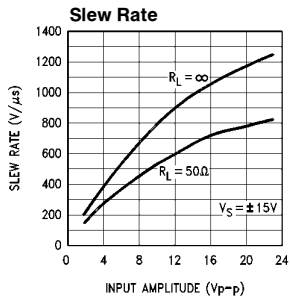
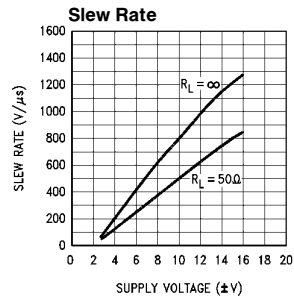
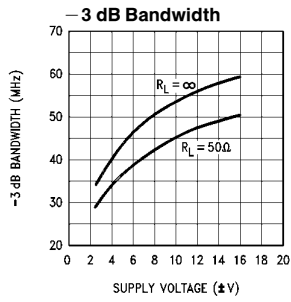
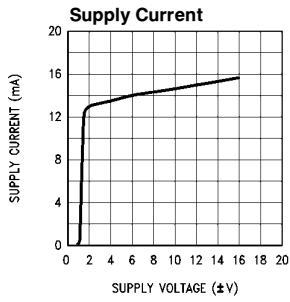

TL/H/9222-7

## Typical Connection Diagram

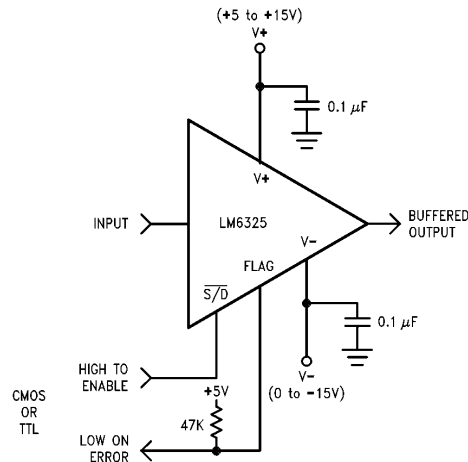

TL/H/9222-6

## Application Hints

### POWER SUPPLY DECOUPLING

The method of supply bypassing is not critical for stability of the LM6125 series buffers. However, their high current output combined with high slew rate can result in significant voltage transients on the power supply lines if much inductance is present. For example, a slew rate of  $900 \text{ V}/\mu\text{s}$  into a  $50\Omega$  load produces a  $di/dt$  of  $18 \text{ A}/\mu\text{s}$ . Multiplying this by a wiring inductance of  $50 \text{ nH}$  results in a  $0.9\text{V}$  transient. To minimize this problem use high quality decoupling very close to the device. Suggested values are a  $0.1 \mu\text{F}$  ceramic in parallel with one or two  $2.2 \mu\text{F}$  tantalums. A ground plane is recommended.

### LOAD IMPEDANCE

The LM6125 is stable into any load when driven by a  $50\Omega$  source. As shown in the *Overshoot vs Capacitive Load* graph, worst case is a purely capacitive load of about  $1000 \text{ pF}$ . Shunting the load capacitance with a resistor will reduce overshoot.

### SOURCE INDUCTANCE

Like any high-frequency buffer, the LM6125 can oscillate at high values of source inductance. The worst case condition occurs at a purely capacitive load of  $50 \text{ pF}$  where up to  $100 \text{ nH}$  of source inductance can be tolerated. With a  $50\Omega$  load, this goes up to  $200 \text{ nH}$ . This sensitivity may be reduced at the expense of a slight reduction in bandwidth by adding a resistor in series with the buffer input. A  $100\Omega$  resistor will ensure stability with source inductances up to  $400 \text{ nH}$  with any load.

### ERROR FLAG LOGIC

The Error Flag pin is an open-collector output which requires an external pull-up resistor. Flag voltage is HIGH during operation, and is LOW during a fault condition. A fault condition occurs if either the internal current limit or the thermal shutdown is activated, or the shutdown (S/D) pin is driven low by external logic. Flag voltage returns to its HIGH state when normal operation resumes.

If the S/D pin is not to be used, it should be connected to  $V+$ .

### OVERVOLTAGE PROTECTION

The LM6125 may be severely damaged or destroyed if the Absolute Maximum Rating of  $7\text{V}$  between input and output pins is exceeded.

If the buffer's input-to-output differential voltage is allowed to exceed  $7\text{V}$ , a base-emitter junction will be in reverse-breakdown, and will be in series with a forward-biased base-emitter junction. Referring to the LM6125 simplified schematic, the transistors involved are Q1 and Q3 for positive inputs, and Q2 and Q4 for negative inputs. If any current is allowed to flow through these junctions, localized heating of the reverse-biased junction will occur, potentially causing damage. The effect of the damage is typically increased offset voltage, increased bias current, and/or degraded AC performance. The damage is cumulative, and may eventually result in complete device failure.

The device is best protected by the insertion of the parallel combination of a  $100 \text{ k}\Omega$  resistor (R1) and a small capacitor (C1) in series with the buffer input, and a  $100 \text{ k}\Omega$  resistor (R2) from input to output of the buffer (see Figure 1). This network normally has no effect on the buffer output. However, if the buffer's current limit or shutdown is activated, and the output has a ground-referred load of significantly less than  $100 \text{ k}\Omega$ , a large input-to-output voltage may be present. R1 and R2 then form a voltage divider, keeping the input-output differential below the  $7\text{V}$  Maximum Rating for input voltages up to  $14\text{V}$ . This protection network should be sufficient to protect the LM6125 from the output of nearly any op amp which is operated on supply voltages of  $\pm 15\text{V}$  or lower.

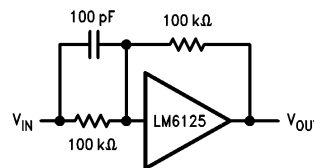

TL/H/9222-8

FIGURE 1. LM6125 with Overvoltage Protection

**Physical Dimensions** inches (millimeters)

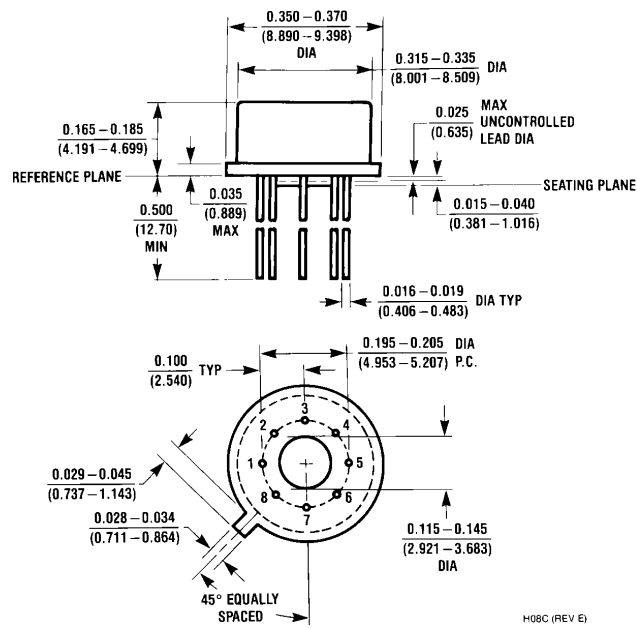

**Metal Can Package (H)**  
**Order Number LM6125H/883 or LM6125H**  
**NS Package Number H08C**

H08C (REV E)

**Physical Dimensions** inches (millimeters) (Continued)

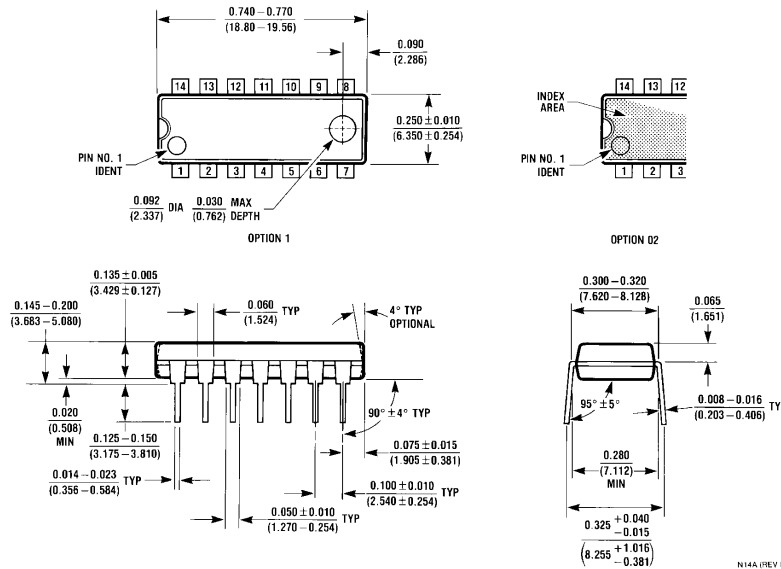

**Molded Dual-In-Line Package (N)**  
**Order Number LM6225N or LM6325N**  
**NS Package Number N14A**

N14A (REV F)

**LIFE SUPPORT POLICY**

NATIONAL'S PRODUCTS ARE NOT AUTHORIZED FOR USE AS CRITICAL COMPONENTS IN LIFE SUPPORT DEVICES OR SYSTEMS WITHOUT THE EXPRESS WRITTEN APPROVAL OF THE PRESIDENT OF NATIONAL SEMICONDUCTOR CORPORATION. As used herein:

1. Life support devices or systems are devices or systems which, (a) are intended for surgical implant into the body, or (b) support or sustain life, and whose failure to perform, when properly used in accordance with instructions for use provided in the labeling, can be reasonably expected to result in a significant injury to the user.
2. A critical component is any component of a life support device or system whose failure to perform can be reasonably expected to cause the failure of the life support device or system, or to affect its safety or effectiveness.



**National Semiconductor Corporation**  
 2900 Semiconductor Drive  
 P.O. Box 58090  
 Santa Clara, CA 95052-8090  
 Tel: 1(800) 272-9959  
 TWX: (910) 339-9240

**National Semiconductor GmbH**  
 Livny-Gargan-Str. 10  
 D-82256 Fürstenfeldbruck  
 Germany  
 Tel: (81-41) 35-0  
 Telex: 527849  
 Fax: (81-41) 35-1

**National Semiconductor Japan Ltd.**  
 Sumitomo Chemical  
 Engineering Center  
 Bldg. 7F  
 1-7-1, Nakase, Mihama-Ku  
 Chiba-City,  
 Ciba Prefecture 261  
 Tel: (043) 299-2300  
 Fax: (043) 299-2500

**National Semiconductor Hong Kong Ltd.**  
 13th Floor, Straight Block,  
 Ocean Centre, 5 Canton Rd.  
 Tsimshatsui, Kowloon  
 Hong Kong  
 Tel: (852) 2737-1600  
 Fax: (852) 2736-9960

**National Semicondutores Do Brazil Ltda.**  
 Rue Deputado Lacorda Franco  
 120-3A  
 Sao Paulo-SP  
 Brazil 05418-000  
 Tel: (55-11) 212-5066  
 Telex: 391-1131931 NSBR BR  
 Fax: (55-11) 212-1181

**National Semiconductor (Australia) Pty. Ltd.**  
 Building 16  
 Business Park Drive  
 Monash Business Park  
 Nottingham, Melbourne  
 Victoria 3168 Australia  
 Tel: (3) 558-9999  
 Fax: (3) 558-9998

National does not assume any responsibility for use of any circuitry described, no circuit patent licenses are implied and National reserves the right at any time without notice to change said circuitry and specifications.