

# LM675

## Power Operational Amplifier

### General Description

The LM675 is a monolithic power operational amplifier featuring wide bandwidth and low input offset voltage, making it equally suitable for AC and DC applications.

The LM675 is capable of delivering output currents in excess of 3 amps, operating at supply voltages of up to 60V. The device overload protection consists of both internal current limiting and thermal shutdown. The amplifier is also internally compensated for gains of 10 or greater.

### Features

- 3A current capability
- $A_{VO}$  typically 90 dB
- 5.5 MHz gain bandwidth product
- 8 V/ $\mu$ s slew rate
- Wide power bandwidth 70 kHz

- 1 mV typical offset voltage
- Short circuit protection
- Thermal protection with parole circuit (100% tested)
- 16V–60V supply range
- Wide common mode range
- Internal output protection diodes
- 90 dB ripple rejection
- Plastic power package TO-220

### Applications

- High performance power op amp
- Bridge amplifiers
- Motor speed controls
- Servo amplifiers
- Instrument systems

### Connection Diagram

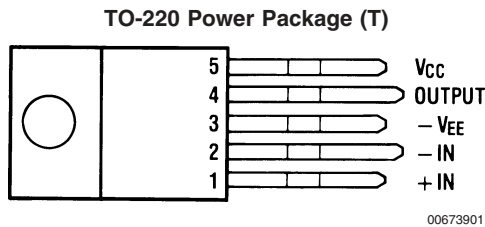

\*The tab is internally connected to pin 3 ( $-V_{EE}$ )

**Front View**  
Order Number LM675T  
See NS Package T05D

### Typical Applications

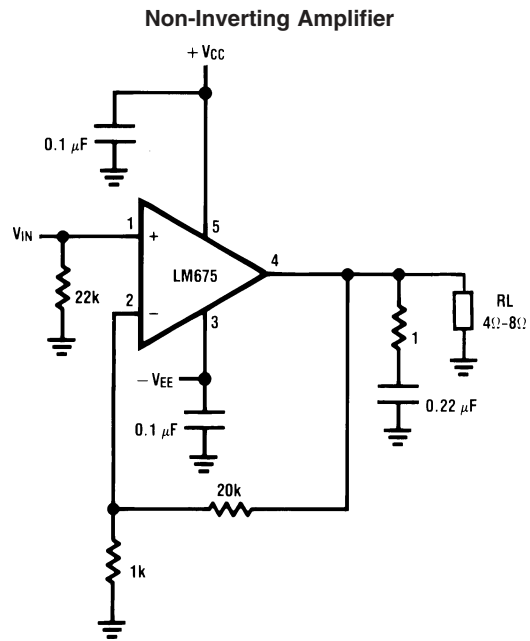

## Absolute Maximum Ratings (Note 1)

If Military/Aerospace specified devices are required, please contact the National Semiconductor Sales Office/Distributors for availability and specifications.

Supply Voltage	±30V
Input Voltage	-V <sub>EE</sub> to V <sub>CC</sub>
Operating Temperature	0°C to +70°C

Storage Temperature	-65°C to +150°C
Junction Temperature	150°C
Power Dissipation (Note 2)	30W
Lead Temperature (Soldering, 10 seconds)	260°C
ESD rating to be determined.	

## Electrical Characteristics

V<sub>S</sub>=±25V, T<sub>A</sub>=25°C unless otherwise specified.

Parameter	Conditions	Typical	Tested Limit	Units
Supply Current	P <sub>OUT</sub> = 0W	18	50 (max)	mA
Input Offset Voltage	V <sub>CM</sub> = 0V	1	10 (max)	mV
Input Bias Current	V <sub>CM</sub> = 0V	0.2	2 (max)	μA
Input Offset Current	V <sub>CM</sub> = 0V	50	500 (max)	nA
Open Loop Gain	R <sub>L</sub> = ∞Ω	90	70 (min)	dB
PSRR	ΔV <sub>S</sub> = ±5V	90	70 (min)	dB
CMRR	V <sub>IN</sub> = ±20V	90	70 (min)	dB
Output Voltage Swing	R <sub>L</sub> = 8Ω	±21	±18 (min)	V
Offset Voltage Drift Versus Temperature	R <sub>S</sub> < 100 kΩ	25		μV/°C
Offset Voltage Drift Versus Output Power		25		μV/W
Output Power	THD = 1%, f <sub>O</sub> = 1 kHz, R <sub>L</sub> = 8Ω	25	20	W
Gain Bandwidth Product	f <sub>O</sub> = 20 kHz, A <sub>VCL</sub> = 1000	5.5		MHz
Max Slew Rate		8		V/μs
Input Common Mode Range		±22	±20 (min)	V

**Note 1:** Absolute Maximum Ratings indicate limits beyond which damage to the device may occur. Operating Ratings indicate conditions for which the device is functional, but do not guarantee specific performance limits. Electrical Characteristics state DC and AC electrical specifications under particular test conditions which guarantee specific performance limits. This assumes that the device is within the Operating Ratings. Specifications are not guaranteed for parameters where no limit is given, however, the typical value is a good indication of device performance.

**Note 2:** Assumes T<sub>A</sub> equal to 70°C. For operation at higher tab temperatures, the LM675 must be derated based on a maximum junction temperature of 150°C.

## Typical Applications

### Generating a Split Supply From a Single Supply

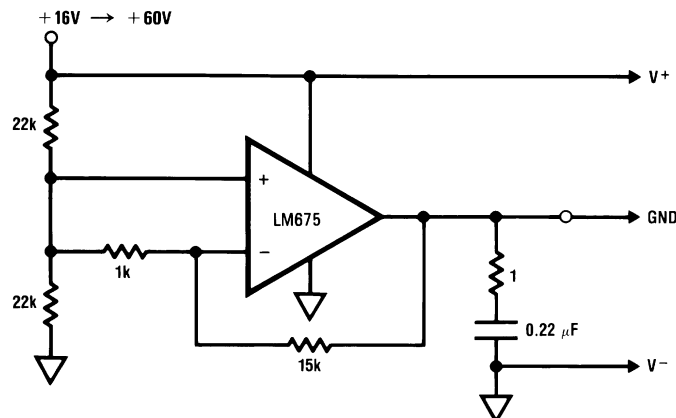

V<sub>S</sub> = ±8V → ±30V

00673903

# Typical Performance Characteristics

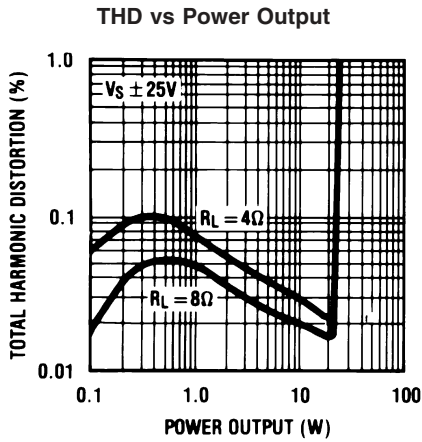

00673910

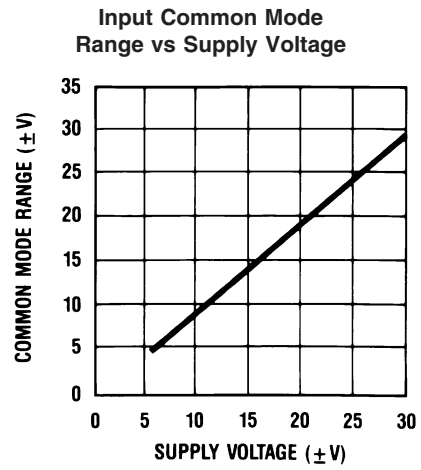

00673911

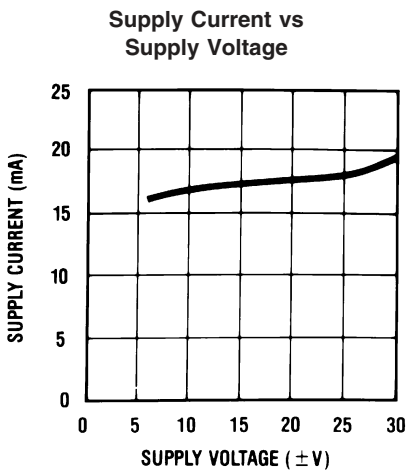

00673912

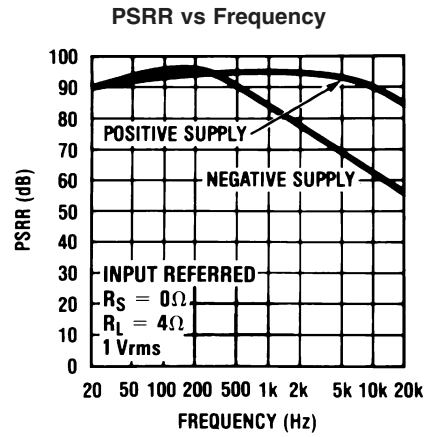

00673913

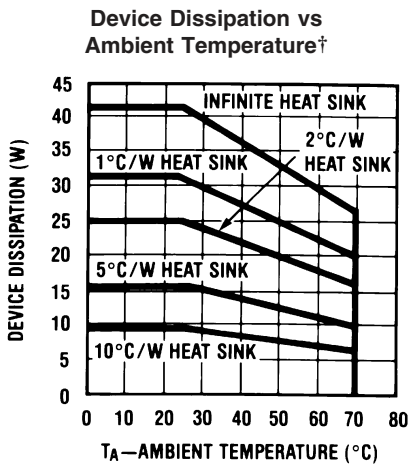

00673914

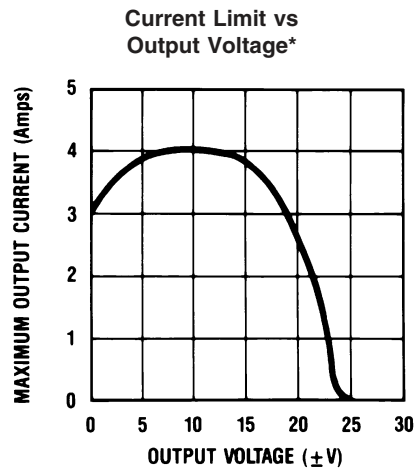

00673915

† $\theta$  INTERFACE = 1 $^{\circ}C/W$   
See Application Hints.

\* $V_S = \pm 25V$

Typical Performance Characteristics (Continued)

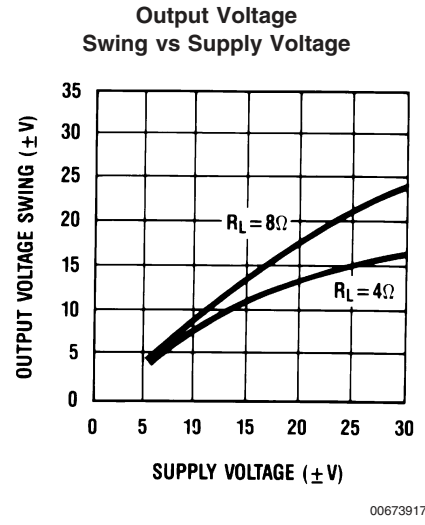
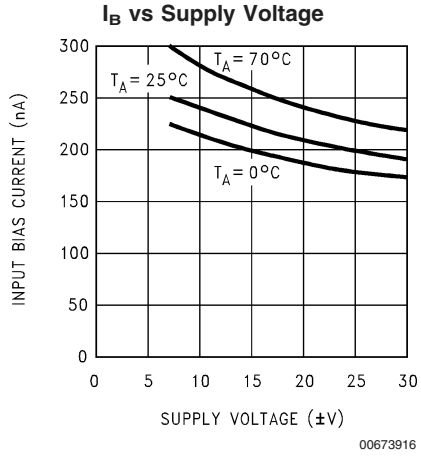

# Schematic Diagram

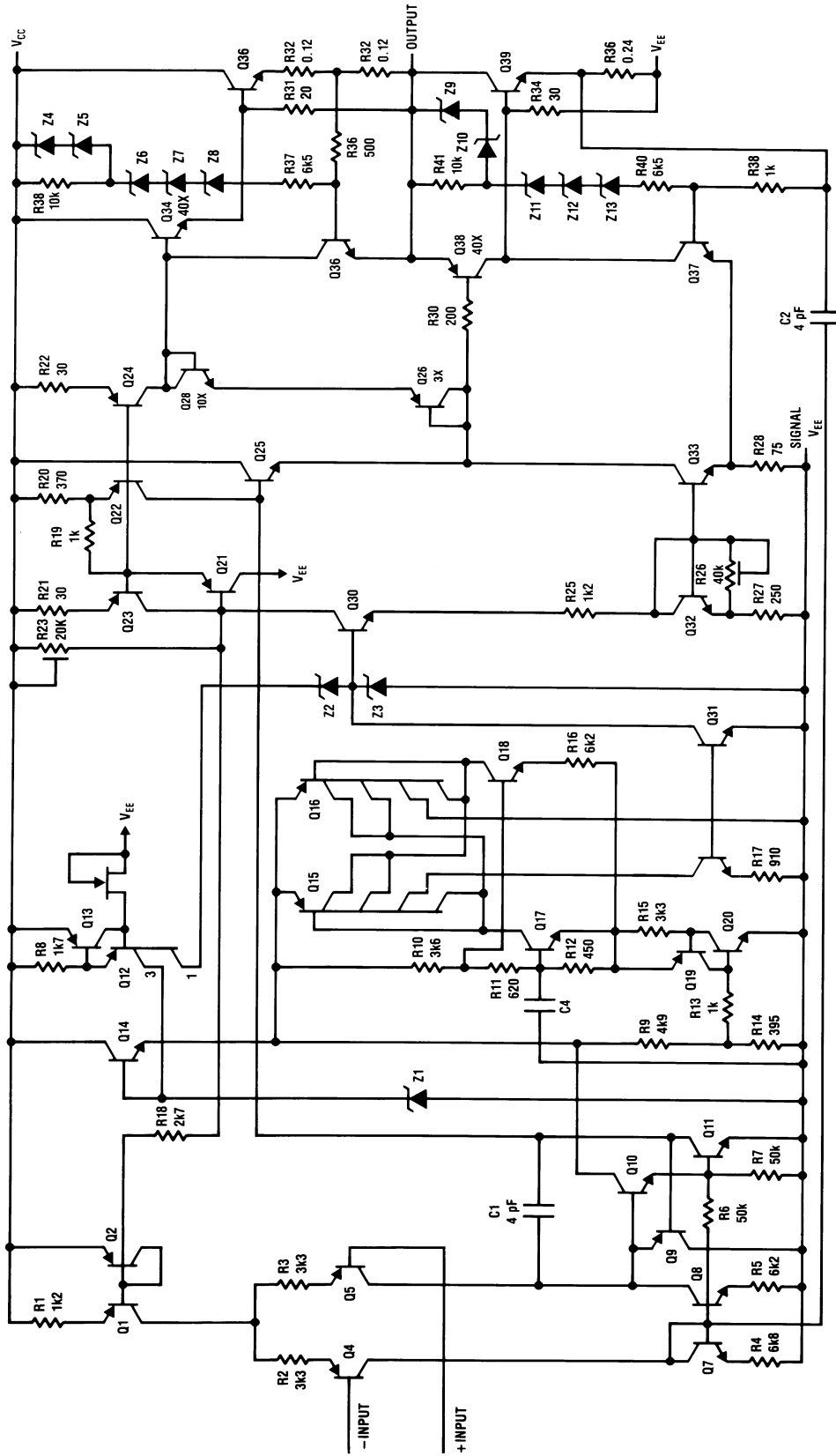

00673905

## Application Hints

### STABILITY

The LM675 is designed to be stable when operated at a closed-loop gain of 10 or greater, but, as with any other high-current amplifier, the LM675 can be made to oscillate under certain conditions. These usually involve printed circuit board layout or output/input coupling.

When designing a printed circuit board layout, it is important to return the load ground, the output compensation ground, and the low level (feedback and input) grounds to the circuit board ground point through separate paths. Otherwise, large currents flowing along a ground conductor will generate voltages on the conductor which can effectively act as signals at the input, resulting in high frequency oscillation or excessive distortion. It is advisable to keep the output compensation components and the 0.1  $\mu\text{F}$  supply decoupling capacitors as close as possible to the LM675 to reduce the effects of PCB trace resistance and inductance. For the same reason, the ground return paths for these components should be as short as possible.

Occasionally, current in the output leads (which function as antennas) can be coupled through the air to the amplifier input, resulting in high-frequency oscillation. This normally happens when the source impedance is high or the input leads are long. The problem can be eliminated by placing a small capacitor (on the order of 50 pF to 500 pF) across the circuit input.

Most power amplifiers do not drive highly capacitive loads well, and the LM675 is no exception. If the output of the LM675 is connected directly to a capacitor with no series resistance, the square wave response will exhibit ringing if the capacitance is greater than about 0.1  $\mu\text{F}$ . The amplifier can typically drive load capacitances up to 2  $\mu\text{F}$  or so without oscillating, but this is not recommended. If highly capacitive loads are expected, a resistor (at least 1 $\Omega$ ) should be placed in series with the output of the LM675. A method commonly employed to protect amplifiers from low impedances at high frequencies is to couple to the load through a 10 $\Omega$  resistor in parallel with a 5  $\mu\text{H}$  inductor.

### CURRENT LIMIT AND SAFE OPERATING AREA (SOA) PROTECTION

A power amplifier's output transistors can be damaged by excessive applied voltage, current flow, or power dissipation. The voltage applied to the amplifier is limited by the design of the external power supply, while the maximum current passed by the output devices is usually limited by internal circuitry to some fixed value. Short-term power dissipation is usually not limited in monolithic operational power amplifiers, and this can be a problem when driving reactive loads, which may draw large currents while high voltages appear on the output transistors. The LM675 not only limits current to around 4A, but also reduces the value of the limit current when an output transistor has a high voltage across it.

When driving nonlinear reactive loads such as motors or loudspeakers with built-in protection relays, there is a possibility that an amplifier output will be connected to a load whose terminal voltage may attempt to swing beyond the power supply voltages applied to the amplifier. This can cause degradation of the output transistors or catastrophic failure of the whole circuit. The standard protection for this type of failure mechanism is a pair of diodes connected between the output of the amplifier and the supply rails.

These are part of the internal circuitry of the LM675, and needn't be added externally when standard reactive loads are driven.

### THERMAL PROTECTION

The LM675 has a sophisticated thermal protection scheme to prevent long-term thermal stress to the device. When the temperature on the die reaches 170°C, the LM675 shuts down. It starts operating again when the die temperature drops to about 145°C, but if the temperature again begins to rise, shutdown will occur at only 150°C. Therefore, the device is allowed to heat up to a relatively high temperature if the fault condition is temporary, but a sustained fault will limit the maximum die temperature to a lower value. This greatly reduces the stresses imposed on the IC by thermal cycling, which in turn improves its reliability under sustained fault conditions. This circuitry is 100% tested without a heat sink.

Since the die temperature is directly dependent upon the heat sink, the heat sink should be chosen for thermal resistance low enough that thermal shutdown will not be reached during normal operation. Using the best heat sink possible within the cost and space constraints of the system will improve the long-term reliability of any power semiconductor.

### POWER DISSIPATION AND HEAT SINKING

The LM675 should always be operated with a heat sink, even though at idle worst case power dissipation will be only 1.8W (30 mA x 60V) which corresponds to a rise in die temperature of 97°C above ambient assuming  $\theta_{jA} = 54^\circ\text{C/W}$  for a TO-220 package. This in itself will not cause the thermal protection circuitry to shut down the amplifier when operating at room temperature, but a mere 0.9W of additional power dissipation will shut the amplifier down since  $T_j$  will then increase from 122°C (97°C + 25°C) to 170°C.

In order to determine the appropriate heat sink for a given application, the power dissipation of the LM675 in that application must be known. When the load is resistive, the maximum average power that the IC will be required to dissipate is approximately:

$$P_D(\text{MAX}) \approx \frac{V_S^2}{2\pi^2 R_L} + P_Q$$

where  $V_S$  is the total power supply voltage across the LM675,  $R_L$  is the load resistance and  $P_Q$  is the quiescent power dissipation of the amplifier. The above equation is only an approximation which assumes an "ideal" class B output stage and constant power dissipation in all other parts of the circuit. As an example, if the LM675 is operated on a 50V power supply with a resistive load of 8 $\Omega$ , it can develop up to 19W of internal power dissipation. If the die temperature is to remain below 150°C for ambient temperatures up to 70°C, the total junction-to-ambient thermal resistance must be less than

$$\frac{150^\circ\text{C} - 70^\circ\text{C}}{19\text{W}} = 4.2^\circ\text{C/W.}$$

Using  $\theta_{jC} = 2^\circ\text{C/W}$ , the sum of the case-to-heat sink interface thermal resistance and the heat-sink-to-ambient thermal resistance must be less than 2.2°C/W. The case-to-heat-sink thermal resistance of the TO-220 package varies with the mounting method used. A metal-to-metal interface will be about 1°C/W if lubricated, and about 1.2°C/W if dry. If a mica insulator is used, the thermal resistance will be about

## Application Hints (Continued)

1.6°C/W lubricated and 3.4°C/W dry. For this example, we assume a lubricated mica insulator between the LM675 and the heat sink. The heat sink thermal resistance must then be less than

$$4.2^{\circ}\text{C/W} - 2^{\circ}\text{C/W} - 1.6^{\circ}\text{C/W} = 0.6^{\circ}\text{C/W}.$$

This is a rather large heat sink and may not be practical in some applications. If a smaller heat sink is required for reasons of size or cost, there are two alternatives. The maximum ambient operating temperature can be restricted to 50°C (122°F), resulting in a 1.6°C/W heat sink, or the heat sink can be isolated from the chassis so the mica washer is not needed. This will change the required heat sink to a 1.2°C/W unit if the case-to-heat-sink interface is lubricated.

The thermal requirements can become more difficult when an amplifier is driving a reactive load. For a given magnitude of load impedance, a higher degree of reactance will cause a higher level of power dissipation within the amplifier. As a general rule, the power dissipation of an amplifier driving a 60° reactive load will be roughly that of the same amplifier driving the resistive part of that load. For example, some reactive loads may at some frequency have an impedance with a magnitude of 8Ω and a phase angle of 60°. The real part of this load will then be 8Ω x cos 60° or 4Ω, and the amplifier power dissipation will roughly follow the curve of power dissipation with a 4Ω load.

## Typical Applications

### Non-Inverting Unity Gain Operation

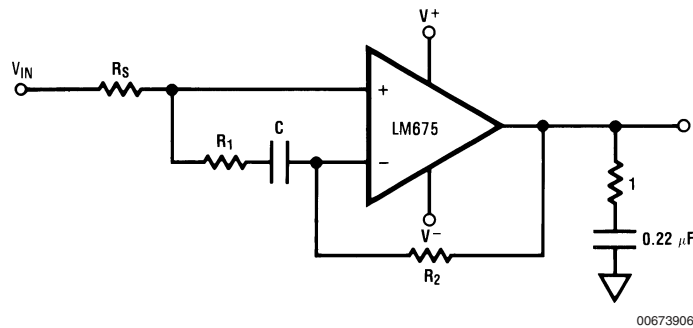

00673906

$$R_1 C \geq \frac{1}{2\pi 500 \text{ kHz}}$$

$$R_1 \leq \frac{R_S + R_2}{10}$$

$$A_{V(\text{DC})} = 1$$

$$\text{UNITY GAIN BANDWIDTH} \approx 50 \text{ kHz}$$

### Inverting Unity Gain Operation

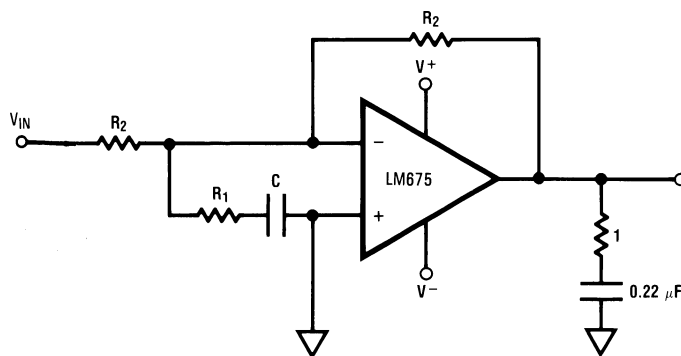

00673907

$$R_1 C \geq \frac{1}{2\pi 500 \text{ kHz}}$$

$$R_1 \leq \frac{R_2}{10}$$

$$A_{V(\text{DC})} = -1$$

$$\text{UNITY GAIN BANDWIDTH} \approx 50 \text{ kHz}$$

## Typical Applications (Continued)

### Servo Motor Control

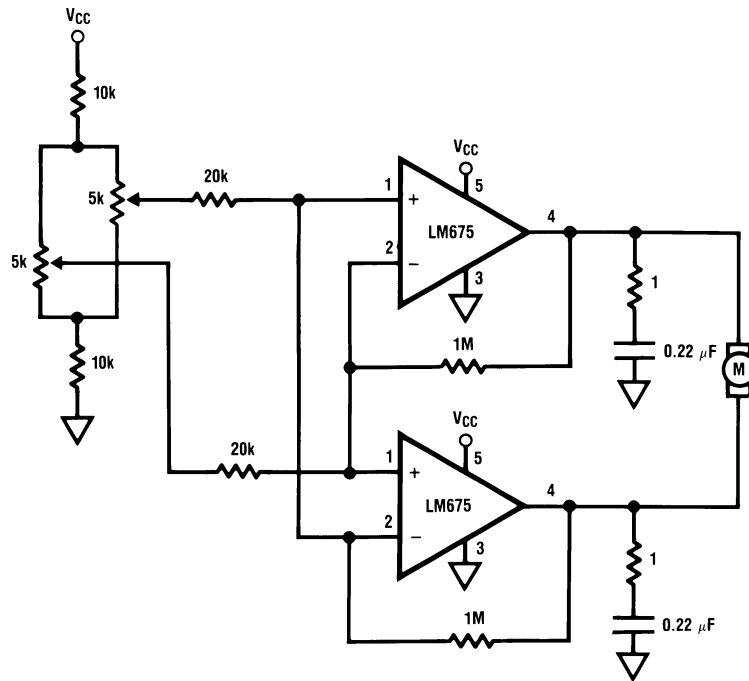

00673908

### High Current Source/Sink

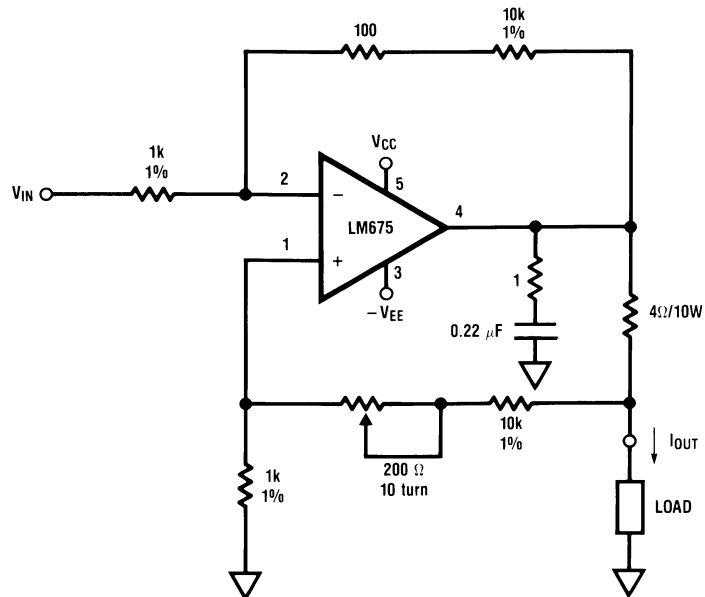

00673909

$I_{OUT} = V_{IN} \times 2.5 \text{ amps/volt}$   
 i.e.  $I_{OUT} = 1\text{A}$  when  $V_{IN} = 400 \text{ mV}$   
 Trim pot for max  $R_{OUT}$

**Physical Dimensions** inches (millimeters) unless otherwise noted

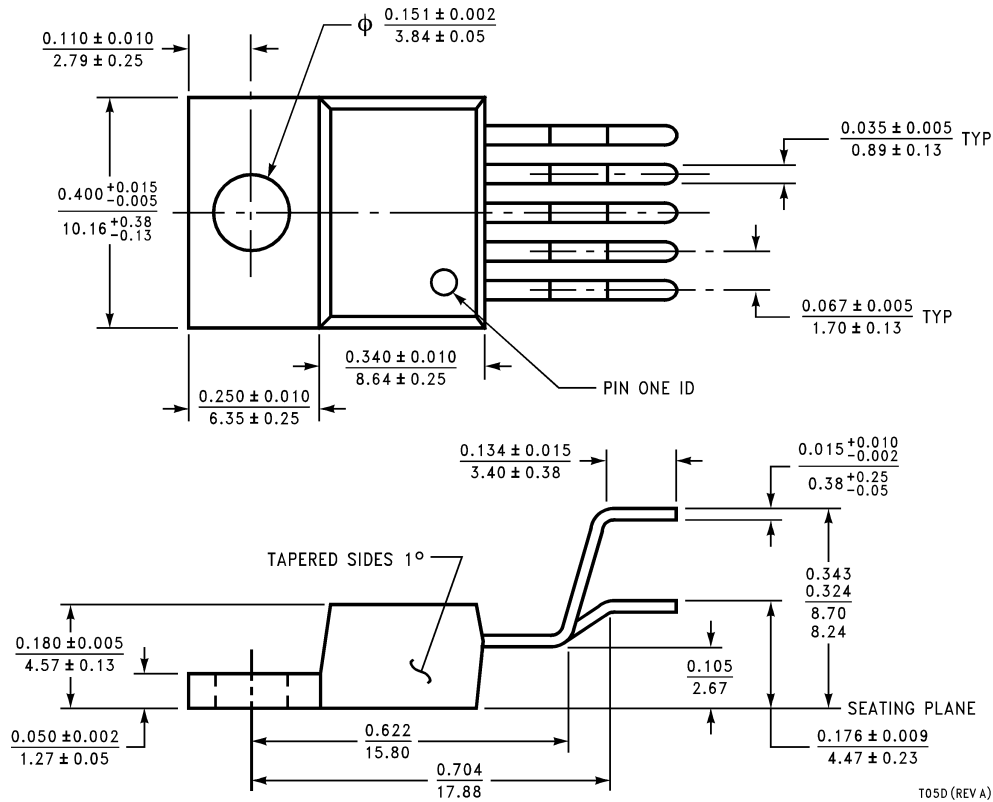

**TO-220 Power Package (T)**  
**Order Number LM675T**  
**NS Package T05D**

National does not assume any responsibility for use of any circuitry described, no circuit patent licenses are implied and National reserves the right at any time without notice to change said circuitry and specifications.

For the most current product information visit us at [www.national.com](http://www.national.com).

**LIFE SUPPORT POLICY**

NATIONAL'S PRODUCTS ARE NOT AUTHORIZED FOR USE AS CRITICAL COMPONENTS IN LIFE SUPPORT DEVICES OR SYSTEMS WITHOUT THE EXPRESS WRITTEN APPROVAL OF THE PRESIDENT AND GENERAL COUNSEL OF NATIONAL SEMICONDUCTOR CORPORATION. As used herein:

1. Life support devices or systems are devices or systems which, (a) are intended for surgical implant into the body, or (b) support or sustain life, and whose failure to perform when properly used in accordance with instructions for use provided in the labeling, can be reasonably expected to result in a significant injury to the user.
2. A critical component is any component of a life support device or system whose failure to perform can be reasonably expected to cause the failure of the life support device or system, or to affect its safety or effectiveness.

**BANNED SUBSTANCE COMPLIANCE**

National Semiconductor certifies that the products and packing materials meet the provisions of the Customer Products Stewardship Specification (CSP-9-111C2) and the Banned Substances and Materials of Interest Specification (CSP-9-111S2) and contain no "Banned Substances" as defined in CSP-9-111S2.



**National Semiconductor**  
**Americas Customer**  
**Support Center**  
 Email: [new.feedback@nsc.com](mailto:new.feedback@nsc.com)  
 Tel: 1-800-272-9959

**National Semiconductor**  
**Europe Customer Support Center**  
 Fax: +49 (0) 180-530 85 86  
 Email: [europe.support@nsc.com](mailto:europe.support@nsc.com)  
 Deutsch Tel: +49 (0) 69 9508 6208  
 English Tel: +44 (0) 870 24 0 2171  
 Français Tel: +33 (0) 1 41 91 8790

**National Semiconductor**  
**Asia Pacific Customer**  
**Support Center**  
 Email: [ap.support@nsc.com](mailto:ap.support@nsc.com)

**National Semiconductor**  
**Japan Customer Support Center**  
 Fax: 81-3-5639-7507  
 Email: [jpn.feedback@nsc.com](mailto:jpn.feedback@nsc.com)  
 Tel: 81-3-5639-7560